

पाइप नट — विशिष्टि
(तीसरा पुनरीक्षण)

Pipe Nuts — Specification
(Third Revision)

ICS 21.060.20

© BIS 2024



भारतीय मानक ब्यूरो
BUREAU OF INDIAN STANDARDS
मानक भवन, 9 बहादुर शाह ज़फर मार्ग, नई दिल्ली - 110002
MANAK BHAVAN, 9 BAHADUR SHAH ZAFAR MARG
NEW DELHI - 110002

www.bis.gov.in www.standardsbis.in

FOREWORD

This Indian Standard (Third Revision) was adopted by the Bureau of Indian Standards, after the draft finalized by the General Engineering and Fasteners Standards Sectional Committee had been approved by the Production and General Engineering Division Council.

This standard was first published in 1966 and subsequently revised in 1975 and 1991. This revision has been brought out to keep pace with the latest technological developments and international practices. In this revision following major changes have been made:

- a) The various requirements of pipe nuts have been updated based on the latest international practices (see [Table 2](#));
- b) The designation of pipe nuts has been specified with better explanation;
- c) Changes have been made in the table on dimensions of pipe nuts; and
- d) References have been updated.

In the preparation of this standard, considerable assistance has been derived from DIN 431 : 2013.

The composition of the Committee, responsible for the formulation of this standard is given in [Annex B](#).

For the purpose of deciding whether a particular requirement of this standard is complied with, the final value, observed or calculated, expressing the result of a test, shall be rounded off in accordance with IS 2 : 2022 'Rules for rounding off numerical values (*second revision*)'. The number of significant places retained in the rounded off value should be the same as that of the specified value in this standard.

Indian Standard
PIPE NUTS — SPECIFICATION
(Third Revision)

1 SCOPE

This standard specifies the requirements for pipe nuts in the size range G 1/8 to G 6 (hexagon and octagon) with threads as specified in IS 2643 and of product grades B and C.

2 REFERENCES

The standards listed in [Annex A](#) contain provisions which, through reference in this text, constitute provisions of this standard. At the time of publication, the editions indicated were valid. All standards are subject to revision, and parties to agreements based on this standard are encouraged to investigate the possibility of applying the most recent edition of these standards.

3 TYPES

Pipe nuts shall be of the following 2 types:

- a) Type 1 : Unchamfered pipe nuts
- b) Type 2 : Chamfered pipe nuts

4 DIMENSIONS

The dimensions and the shapes of the nuts shall be as given in [Fig.1](#) and [Table 1](#).

5 REQUIREMENTS

The various requirements of the pipe nuts shall be as specified in [Table 2](#).

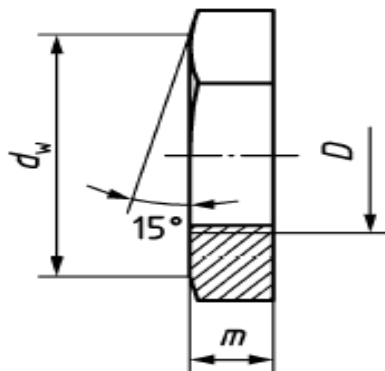

Type 1 (Unchamfered)

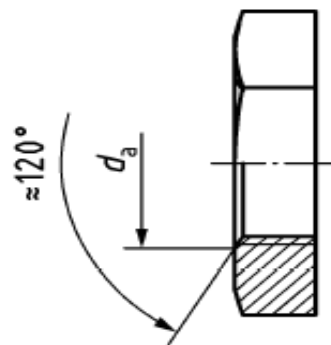

Type 2 (Chamfered)

(Other dimensions are same as Type 1)

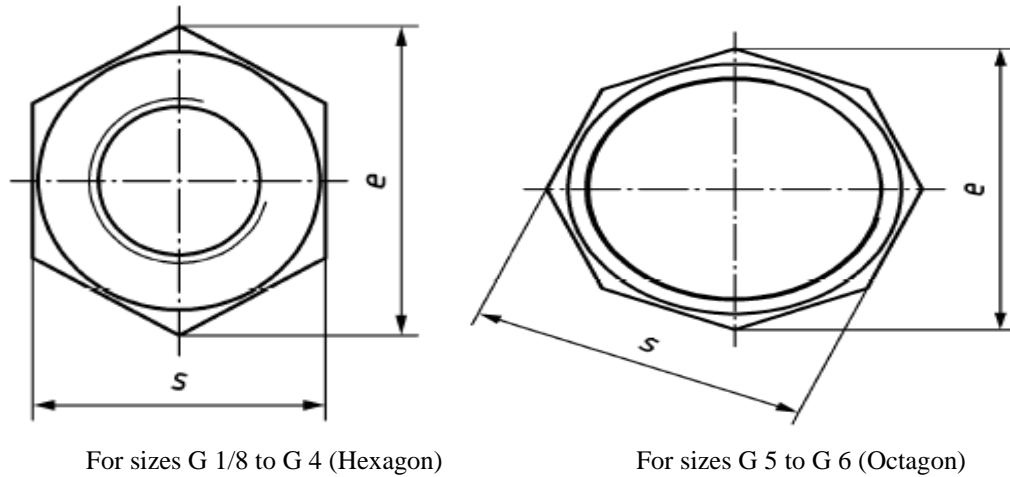

FIG. 1 NUT DIMENSIONS (TYPE 1 AND TYPE 2)

Table 1 Dimensions for Pipe Nuts

(Clause 4)

All dimensions are in millimetres

SI No.	Thread Size d	d_a Max	d_w Min	e Min	m		S	
					Max ¹⁾	Min	Max	Min
(1)	(2)	(3)	(4)	(5)	(6)		(7)	
i)	G 1/8	10.5	16.5	19.85	6.48	6	18	17.57
ii)	G 1/4	14.2	19.1	22.78	6.48	6	21	20.16
iii)	G 3/8	18	24.8	29.56	7.58	7	27	26.16
iv)	G 1/2	22.6	31.3	37.29	8.58	8	34	33
v)	(G 5/8)	24.7	31.3	37.29	8.58	8	34	33
vi)	G 3/4	28.6	32.3	39.55	9.58	9	36	34
vii)	G 7/8	32.6	38	45.20	9.58	9	41	40
viii)	G 1	35.9	42.8	50.85	10.58	10	46	45
ix)	(G 1 1/8)	40.9	46.5	55.37	10.58	10	50	49
x)	G 1 1/4	45.3	51.1	60.79	11.70	11	55	53.8
xi)	G 1 1/2	51.6	55.9	66.44	12.70	12	60	58.8
xii)	(G 1 3/4)	58	64.7	76.93	13.70	13	70	68.1
xiii)	G 2	64.4	69.4	82.60	13.70	13	75	73.1
xiv)	(G 2 1/4)	71	78.7	93.56	16.70	16	85	82.8
xv)	G 2 1/2	81.2	88.2	104.86	16.70	16	95	92.8
xvi)	G 3	94.9	97.7	116.16	19.84	19	105	102.8
xvii)	G 4	122	125.9	149.72	22.84	22	135	132.5
xviii)	G 5	149.5	154.4	183.06	22.84	22	165	162.5
xix)	G 6	177	176.1	209.5	25.84	25	190	185.4

NOTE — Sizes shown within brackets are of second preference.

¹⁾The maximum size applies for type 2 nuts. In the case of type 1 nuts, m is to be larger by a machining allowance.

Table 2 Requirements of Pipe Nuts*(Clause 5)*

SI No.	Material		Steel	Stainless Steel	Non-ferrous Metal
(1)	(2)	(3)	(4)	(5)	(6)
i)	General Requirements	As specified in	IS 1367 (Part 1)		
ii)	Thread	As specified in	IS 2643		
iii)	Mechanical properties	Grade	14H	A2	Brass having minimum tensile strength 300 MPa
		As specified in	IS 1367 (Part 7)	IS 1367 (Part 14/ Sec 2)	
iv)	Limit deviations and Geometrical tolerances	Product grade	C for type 1 and B for type 2		
		As specified in	IS 1367 (Part 2)		
v)	Surface finish	As specified in	<p>As processed (no coating)</p> <p>Electroplated coatings as specified in IS 1367 (Part 11)</p> <p>Non-electrolytically applied zinc flake coatings as specified in IS 10683</p> <p>Hot dip galvanized coatings as specified in IS 1367 (Part 13)</p> <p>Additional requirements or other surface finishes or coatings shall be agreed between the supplier and the customer</p>	Clean and bright and/or passivated	<p>As processed (no coating)</p> <p>Electroplated coatings as specified in IS 1367 (Part 11)</p>
vi)	Surface condition	As specified in	IS 1367 (Part 10)		
vii)	Acceptance inspection	As specified in	IS 1367 (Part 17)		

6 DESIGNATION

6.1 The pipe nuts shall be designated by type, thread size, property grade of material and IS No. of this standard.

Example:

A pipe nut of thread size G 6, type 1, and made up of steel of grade 14H shall be designated as:

Pipe Nut — 1 — G 6 — 14H IS 3468

6.2 When the pipe nuts are manufactured from brass, the word 'Brass' shall be added at the end of the designation.

Example:

A pipe nut of thread size G 3/8, type 1 and made from brass shall be designated as

Pipe Nut — 1 — G 3/8 — Brass IS 3468

7 MARKING

7.1 Marking of the pipe nuts shall be in accordance with IS 1367 (Part 18).

7.2 BIS Certification Marking

The product(s) conforming to the requirements of this standard may be certified as per the conformity assessment schemes under the provisions of the *Bureau of Indian Standards Act, 2016* and the Rules and Regulations framed thereunder, and the products may be marked with the standard mark.

ANNEX A

(Clause 2)

LIST OF REFERRED STANDARDS

<i>IS No./Others Standard</i>	<i>Title</i>	<i>IS No./Others Standard</i>	<i>Title</i>
IS 1367	Technical supply conditions for threaded steel fasteners:	(Part 17) : 2005/ ISO 3269 : 2000	Inspections sampling and acceptance procedure (<i>fourth revision</i>)
(Part 1) : 2014/ ISO 8992 : 2005	General requirements for bolts, screws, studs and nuts (<i>fourth revision</i>)	IS 1367 (Part 18) : 1996	Industrial fasteners — Threaded steel fasteners — Technical supply conditions: Part 18 Packaging (<i>third revision</i>)
(Part 2) : 2002/ ISO 4759-1 : 2000	Tolerances for fasteners — Bolts, screws, studs and nuts — Product grades a, b and c (<i>third revision</i>)	IS 2643 : 2005/ ISO 228-1 : 2000	Pipe threads where pressure-tight joints are not made on the threads — Dimensions tolerances and designation (<i>third revision</i>)
(Part 7) : 1980	Mechanical properties and test methods for nuts without specified proof loads (<i>second revision</i>)	IS 9519 : 2005/ ISO 272 : 1982	Fasteners — Hexagon products — Width across flats (<i>first revision</i>)
(Part 10) : 2002/ ISO 6157-2 : 1995	Surface discontinuities — Nuts (<i>third revision</i>)	IS/ISO 10683 : 2018	Fasteners — Non-electrolytically applied zinc flake coating systems
(Part 11) : 2020/ ISO 4042 : 2018	Electroplated coating systems (<i>fourth revision</i>)		
(Part 14/Sec 2) : 2018/ISO 3506-2 : 2009	Mechanical properties of corrosion-resistant stainless-steel fasteners, Section 2 Nuts with specified grades and property classes (<i>fifth revision</i>)		

To access Indian Standard click on the link below:

https://www.services.bis.gov.in/php/BIS_2.0/bisconnect/knowyourstandards/Indian_standards/isdetails/

ANNEX B

(Foreword)

COMMITTEE COMPOSITION

General Engineering and Fasteners Standards Sectional Committee, PGD 37

<i>Organization</i>	<i>Representatives(s)</i>
In Personal Capacity (9, Shantha Sadana, 4th Cross, F - Block, 1st Stage, J. P. Nagar)	SHRI N. SRINIVASA MURTHY (Chairperson)
Asp Private Limited, Hawrah	SHRI VINOD SHARMA SHRI B. BHAUMIK (<i>Alternate</i>)
BEML Limited, Bengaluru	SHRI S. K.SAHA SHRI T. N. SRINIVAS (<i>Alternate I</i>) SHRI M. R. SENTHIL KUMAR (<i>Alternate II</i>)
Bharat Dynamics Limited, Hyderabad	SHRI K. SREENIVASA RAO SHRI UMAKANTH PATHIPATI (<i>Alternate</i>)
Bharat Heavy Electrical Limited, New Delhi	SHRI AVINASH S. JOHN SHRI KALYAN A. (<i>Alternate I</i>) SHRI LALIT KUMAR (<i>Alternate II</i>)
Bosch Limited, Bengaluru	SHRI KUMARASWAMY S.
Central Manufacturing Technology Institute, Bengaluru	SHRI ANIL KUMAR SHRI S. K. VERMA (<i>Alternate</i>)
CSIR - National Aerospace Laboratories, Bengaluru	SHRI S. RAVISHANKAR SHRI M. S. KAMLESHAIAH (<i>Alternate</i>)
CSIR - National Physical Laboratory, New Delhi	SHRI ANIL KUMAR SHRI GAUTAM MANDAL (<i>Alternate I</i>) SHRIMATI NIDHI SINGH (<i>Alternate II</i>)
Deepak Fasteners Limited, Ludhiana	SHRI SANJEEV KALRA SHRI DEEPAK KALRA (<i>Alternate I</i>) SHRI SUKHJEEVAN SINGH (<i>Alternate II</i>)
Directorate General of Quality Assurance, Ministry of Defence, Kanpur	SHRI J. K. YADAV SHRI S. L. MEENA (<i>Alternate</i>)
Directorate General of Quality Assurance, Ministry of Defence, New Delhi	SHRI BIJENDRA KUMAR
Hilti India Private Limited, New Delhi	SHRI PRASHANT DASHARATH SATHE SHRI SHOUNAK MITRA (<i>Alternate</i> ALTERNATE)

<i>Organization</i>	<i>Representatives(s)</i>
Hindustan Fasteners Private Limited, Nasik	SHRI INDRAPAL
HMT Limited, Bengaluru	SHRI C. S. VIJAYA PRAKASH SHRI SOMASUNDARAM (<i>Alternate</i>)
Indian Institute of Technology Bombay, Mumbai	DR PANKAJ KUMAR
MK Fasteners, Bengaluru	SHRI KUNTHAL AMEN
National Test House, Kolkata	SHRI S. P. ROY SHRI YOGESH SINGH (<i>Alternate</i>)
Nexo Industries Private Limited, Ludhiana	SHRI AMRIK SINGH
Pooja Forge Limited, Faridabad	SHRI JAGDISH K. AGGARWAL
Precise Fasteners Private Limited, Mumbai	SHRI PARAG PRAKASH
Right Tight Fasteners Private Limited, Nashik	SHRI BALVEER SHRI AMARJEET SINGH (<i>Alternate</i>)
Size Control Gauges & Tools Private Limited, Pune	SHRI ATUL ASHOK DURVE
Sundram Fasteners Limited, Chennai	SHRI ATUL KUMAR AGRAWAL SHRI KANNADASAN B (<i>Alternate</i>)
Tata Motors Limited, Pune	SHRI SAGAR TALOLE SHRI R. R. KULKARNI (<i>Alternate</i>)
Unison Clamping Devices Limited, Pune	SHRI PANDURANG KALLAPPA SAWANT SHRI VIKRAM P. SAWANT (<i>Alternate</i>)
In Personal Capacity (<i>199/1, 9th Cross, Cubbonpet Bengaluru</i>)	SHRI MURTHY
In Personal Capacity (<i>G-A/42 APHB Phase 3, Saidabad</i>)	SHRI K. V. SUBBA REDDY
BIS Directorate General	SHRI RAJEEV RANJAN SINGH, SCIENTIST 'F'/SENIOR DIRECTOR AND HEAD (PRODUCTION AND GENERAL ENGINEERING)[REPRESENTING DIRECTOR GENERAL (<i>Ex-officio</i>)]

Member Secretary
SHRI MONARCH JOSHI
SCIENTIST 'B'/ASSISTANT DIRECTOR
(PRODUCTION AND GENERAL ENGINEERING) BIS

Bureau of Indian Standards

BIS is a statutory institution established under the *Bureau of Indian Standards Act, 2016* to promote harmonious development of the activities of standardization, marking and quality certification of goods and attending to connected matters in the country.

Copyright

BIS has the copyright of all its publications. No part of these publications may be reproduced in any form without the prior permission in writing of BIS. This does not preclude the free use, in the course of implementing the standard, of necessary details, such as symbols and sizes, type or grade designations. Enquiries relating to copyright be addressed to the Head (Publication & Sales), BIS.

Review of Indian Standards

Amendments are issued to standards as the need arises on the basis of comments. Standards are also reviewed periodically; a standard along with amendments is reaffirmed when such review indicates that no changes are needed; if the review indicates that changes are needed, it is taken up for revision. Users of Indian Standards should ascertain that they are in possession of the latest amendments or edition by referring to the website-www.bis.gov.in or www.standardsbis.in.

This Indian Standard has been developed from Doc No.: PGD 37 (18737).

Amendments Issued Since Publication

Amend No.	Date of Issue	Text Affected

BUREAU OF INDIAN STANDARDS

Headquarters:

Manak Bhavan, 9 Bahadur Shah Zafar Marg, New Delhi 110002

Telephones: 2323 0131, 2323 3375, 2323 9402

Website: www.bis.gov.in

Regional Offices:

Central : 601/A, Konnectus Tower -1, 6th Floor,
DMRC Building, Bhavbhuti Marg, New
Delhi 110002

Telephones

{ 2323 7617

Eastern : 8th Floor, Plot No 7/7 & 7/8, CP Block, Sector V,
Salt Lake, Kolkata, West Bengal 700091

{ 2367 0012
{ 2320 9474

Northern : Plot No. 4-A, Sector 27-B, Madhya Marg,
Chandigarh 160019

{ 265 9930

Southern : C.I.T. Campus, IV Cross Road, Taramani, Chennai 600113

{ 2254 1442
{ 2254 1216

Western : 5th Floor/MTNL CETTM, Technology Street, Hiranandani Gardens, Powai
Mumbai 400076

{ 25700030
{ 25702715

Branches : AHMEDABAD, BENGALURU, BHOPAL, BHUBANESHWAR, CHANDIGARH, CHENNAI, COIMBATORE, DEHRADUN, DELHI, FARIDABAD, GHAZIABAD, GUWAHATI, HARYANA (CHANDIGARH), HUBLI, HYDERABAD, JAIPUR, JAMMU, JAMSHEDPUR, KOCHI, KOLKATA, LUCKNOW, MADURAI, MUMBAI, NAGPUR, NOIDA, PARWANOO, PATNA, PUNE, RAIPUR, RAJKOT, SURAT, VIJAYAWADA.