

पाईप रिंच — विशिष्टि  
भाग 1 सामान्य प्रयोजन  
( दूसरा पुनरीक्षण )

Pipe Wrenches — Specification  
Part 1 General Purpose  
( Second Revision )

ICS 25.140.30

© BIS 2024



भारतीय मानक ब्यूरो  
BUREAU OF INDIAN STANDARDS  
मानक भवन, 9 बहादुर शाह ज़फर मार्ग, नई दिल्ली - 110002  
MANAK BHAVAN, 9 BAHADUR SHAH ZAFAR MARG  
NEW DELHI - 110002

[www.bis.gov.in](http://www.bis.gov.in) [www.standardsbis.in](http://www.standardsbis.in)

## FOREWORD

This Indian Standard (Part 1) (Second Revision) was adopted by the Bureau of Indian Standards after the draft finalized by the Hand Tools Sectional Committee had been approved by the Production and General Engineering Division Council.

This standard was first published in 1967 and was subsequently revised in 1978. This revision has been brought out to keep pace with the latest technological developments and international practices.

In this second revision, the following changes have been made:

- a) Clause on references has been added; and
- b) Material designations have been updated as per the latest Indian Standards.

This standard has been published in two parts. Other part in this series is:

Part 2      Heavy duty

The composition of the Committee, responsible for the formulation of this standard is given in [Annex A](#).

For the purpose of deciding whether a particular requirement of this standard is complied with, the final value, observed or calculated, expressing the result of a test, shall be rounded off in accordance with IS 2 : 2022 'Rules for rounding off numerical values (*second revision*)'. The number of significant places retained in the rounded off value should be the same as that of the specified value in this standard.

*Indian Standard*

## PIPE WRENCHES — SPECIFICATION

## PART 1 GENERAL PURPOSE

*( Second Revision )***1 SCOPE**

This standard (Part 1) specifies requirements for general purpose pipe wrenches.

**2 REFERENCES**

The standards given below contain provisions which through reference in this text, constitute provisions of this standard. At the time of publication, the editions indicated were valid. All standards are subject to revision, and parties to agreements based on this standard are encouraged to investigate the possibility of applying the most recent edition of these standards:

<i>IS No.</i>	<i>Title</i>
IS 1570	Schedules for wrought steels:
(Part 2/Sec 1) : 1979	Carbon steels (unalloyed steels), Section 1 Wrought products (other than wires) with specified chemical composition and related properties ( <i>first revision</i> )
(Part 4) : 1988	Alloy steels (alloy constructional and spring steels) with specified chemical composition and related mechanical properties ( <i>first revision</i> )
IS 1865 : 1991	Iron castings with spheroidal or nodular graphite — Specification ( <i>third revision</i> )
IS 2500 (Part 1) : 2000/ISO 2859-1 : 1999	Sampling procedures for inspection by attributes: Part 1 Sampling schemes indexed by acceptance quality limit (AQL) for lot-by-lot inspection ( <i>third revision</i> )
IS 14329 : 1995	Malleable iron castings — Specification

**3 TERMINOLOGY**

For the purpose of this standard, following definitions shall apply:

**3.1 Nominal Size** — The overall length of the tool when the jaws are open to the maximum capacity (*see 4*).

**3.2 Maximum Capacity** — The maximum diameter of pipe that shall be gripped with safety when the end of the movable jaw flushes with back face of the frame.

**3.3 Greatest Angle Movement** — The difference in angles between the jaws at their minimum and maximum possible angular positions.

**4 DIMENSIONS**

The dimensions of pipe wrenches (general purpose) shall be as given in [Table 1](#).

**5 MATERIAL**

**5.1** Material for the construction of different components of pipe wrenches (general purpose) shall be as given in [Table 2](#).

**5.2** Chemical composition of 31CrV3 and 40Cr used in the handle and movable jaw shall be as given in [Table 3](#).

**6 HARDNESS**

**6.1** The hardness of jaws, handle and shank of the movable jaw shall be as given in below:

<i>Sl No.</i>	<i>Component</i>	<i>Hardness</i>
(1)	(2)	(3)
i)	Jaws	490 HV to 700 HV (48 HRC to 60 HRC) when measured at any point within the triangular profile of any tooth or within one millimeter of the root of the tooth
ii)	Handle and shank of the movable jaw	285 HV to 400 HV (30 HRC to 41 HRC)

To access Indian Standards click on the link below:

[https://www.services.bis.gov.in/php/BIS\\_2.0/bisconnect/knowyourstandards/Indian\\_standards/isdetails/](https://www.services.bis.gov.in/php/BIS_2.0/bisconnect/knowyourstandards/Indian_standards/isdetails/)

**6.2** The transitional hardness zone ([Table 1](#)) shall not extend beyond a point defined as twice the height of the teeth measured back from the tooth root.

## 7 MANUFACTURE

### 7.1 Handle

The handle shall be a one-piece forging with integral teeth. The teeth shall be of a definite number, shape and size to enable the assembled tool to meet the test requirements without slipping and to grip positively during normal operation any appropriate diameter of pipe within the safe capacity as given in [4](#). The toothed portion of the handle shall be so positioned that the common plane of the crests of the teeth shall be inclined at an angle of 10° relative to a plane perpendicular to the longitudinal axis of the handle (*see* [4](#)). The crests of the teeth shall be parallel and square relative to the lateral axis of the handle.

### 7.2 Movable Jaw

The movable jaw shall be a one-piece forging with integral teeth. The teeth shall be of adequate number, shape and size to enable the assembled tool to meet the test requirements without slipping and to grip positively during operation any appropriate diameter of pipe within the safe capacity.

**7.2.1** The shank of the movable jaw shall be threaded in order to engage the internal threads of the adjusting nut.

**7.2.2** The toothed portion of the movable jaw shall be so positioned that the common plane of the crests of the teeth shall be square relative to the axis of the threaded shank. The crests of the teeth shall be parallel and shall be square relative to the lateral axis of the threaded shanks.

### 7.3 Adjusting Nut

The adjusting nut shall be suitably knurled or longitudinally serrated. The threads shall be of sufficiently robust form and pitch so that with the jaws set at any point of adjustment within the appropriate capacity (*see* [4](#)), the wrench shall be capable of passing the tests given in [11](#).

### 7.4 Frame

The frame shall be a one-piece casting or one steel piece. It shall be integral with the handle or be

attached to the handle by means of a riveted pin. It shall allow easy adjustment of the movable jaw allowing easy and proper operation of the wrench both forward and backward.

### 7.5 Hinge Pin

When in position the hinge pin shall have heads formed at each end by riveting. Alternatively, it shall be provided with equally effective securing means.

### 7.6 Spring

One or more spring shall be provided; the greatest angle movement shall not exceed 10°. The spring or springs provided in the wrench assembly shall properly balance the movable jaw so that action, both forward and backward, is provided. The spring or springs shall be secured to the frame by riveting or any other suitable means.

## 8 WORKMANSHIP AND FINISH

**8.1** The wrenches shall be free from flaws, cracks, rust, burrs and other injurious defects. The movable jaw shall be properly finished.

**8.2** All unmachined surfaces shall either be painted or suitably treated with rust preventives. The machined surfaces shall be protected by any rust-preventive treatment.

## 9 OPERATION

The motion between the various parts of the wrench shall permit the teeth to grip and hold the pipe for successive turns without the necessity of altering the adjusting nut. The wrench shall release freely when the direction of pressure on the handle is reversed.

## 10 SAMPLING

The representative samples shall be drawn as specified in IS 2500 (Part 1).

## 11 TESTS

### 11.1 Static Load Test

A cylindrical steel test bar shall be rigidly mounted in a test as illustrated diagrammatically in [Fig. 2](#). The test bar shall be of diameter as given in [Table 4](#) and shall have hardness within the range 300 HV to 380 HV at any point on its circumferential surface.

The wrench shall be mounted in the rig with the teeth in normal working engagement with the test bar (see Fig. 2) and a load shall be supplied sufficient to result in a proof torque at point 'P' as given in Table 4. On the completion of test there shall be no permanent deformation or cracking of any portion of the wrench. The threads on the adjusting nut and movable jaw and the adjusting nut itself shall also not show any sign of permanent deformation.

**11.2 Static-Shock Load Test**

The wrench shall be in position as described in 11.1 with static load reduced by 25 percent, with this load in operation the shock load as given in Table 4 shall be applied at the point 'P'. Following this test, the wrench shall release freely when the direction of force on the handle is reversed. The teeth shall then grip and release freely without recourse to alteration of the adjusting nut. On removal from the test figure, the wrench shall be capable of normal finger and thumb adjustment over the whole length of the transverse. The component parts shall not have suffered any permanent set on the completion of the test.

**12 DESIGNATION**

A general-purpose pipe wrench of 200 mm nominal size shall be designated as follows:

Pipe wrench G 200 IS 4003 (Part 1)

**13 MARKING**

**13.1** Pipe wrenches shall be marked with the nominal size, manufacturer's name and/or trademark and month and year of manufacture/batch no.

**13.2 BIS Certification Marking**

The product(s) conforming to the requirements of this standard may be certified as per the conformity assessment schemes under the provisions of the Bureau of Indian Standards Act, 2016 and the Rules and Regulations framed thereunder, and the product(s) may be marked with the Standard Mark.

**14 PACKING**

Each pipe wrench shall be wrapped in grease or waxed paper and then suitably packed in cardboard carton bearing the designation and size of the wrench and the manufacturer's name initials and/or trade-mark.

**Table 1 Dimensions of Pipe Wrenches (General Purpose)**

(Clauses 4 and 6.2)

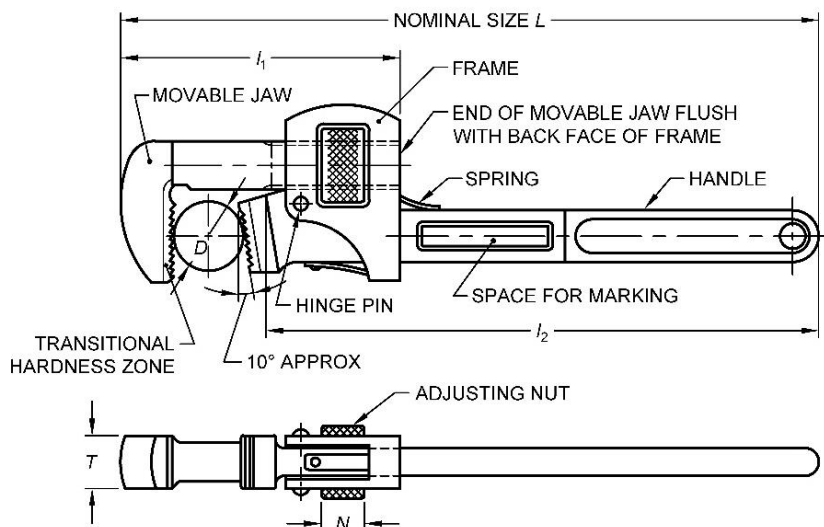

**FIG. 1 PIPE WRENCHES (GENERAL PURPOSE)**

All dimensions in millimetres.

Sl No.	Nominal Size	Minimum Capacity	Maximum Jaw Capacity Thickness		Approximate Length of Movable Jaw	Approximate Length of Handle	Width off Nut
			$D$	$T$ <i>Min</i>			
(1)	(2)	(3)	(4)	(5)	(6)	(7)	(8)
i)	200	6	20	15	85	160	12
ii)	250	6	26	17	110	200	13
iii)	300	9	32	19	125	240	16
iv)	350	13	38	21	140	285	17
v)	450	25	52	24	165	370	18
vi)	600	38	65	28	200	495	25
vii)	900	50	95	34	260	750	35
viii)	1 200	65	130	40	330	1 000	35

Table 2 Material Used for Various Parts of Pipe Wrenches (General Purpose)

(Clause 5.1)

Sl No.	Component	Material
(1)	(2)	(3)
i)	Handle and movable jaw	40C8, 50C4, 55C4, 55C8, 60C4, 65C6 of IS 1570 (Part 2/Sec 1), 31CrV3 or 40Cr
ii)	Frame	Malleable cast iron conforming to IS 14329 or SG Iron grade SG 500/7, 450/10 of IS 1865 or 20C8, 25C4 or 15C4, 15C8 of IS 1570 (Part 2/Sec 1)
iii)	Spring	Steel to designation 50Cr4 of IS 1570 (Part 4) or any suitable grade from IS 1570 (Part 4)
iv)	Adjusting nut and hinge pin	Suitable carbon steel selected from IS 1570 (Part 2/Sec 1)

Table 3 Chemical Composition of Steel Grades

(Clause 5.2)

Sl No.	Grade	C	Si	Mn	S (Max)	P (Max)	Cr	V
(1)	(2)	(3)	(4)	(5)	(6)	(7)	(8)	(9)
i)	31CrV3	0.28 to 0.35	0.25 to 0.40	0.40 to 0.60	0.030	0.030	0.40 to 0.70	0.07 to 0.12
ii)	40Cr	0.37 to 0.44	0.17 to 0.37	0.50 to 0.80	0.030	0.030	0.80 to 1.10	Nil

NOTE — Composition limit in weight percent maximum, unless shown as a range or a minimum.

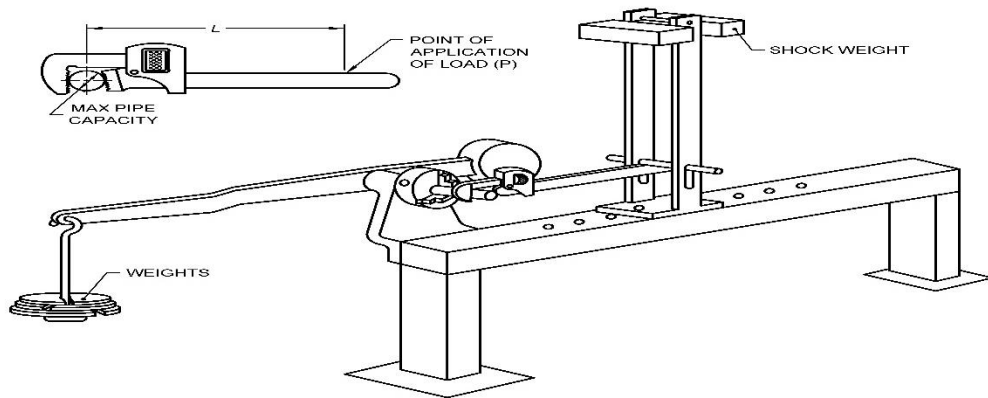

FIG. 2 DIAGRAMMATIC ARRANGEMENT OF TEST RIG

**Table 4 Test Loads for Pipe Wrenches***(Clauses 11.1 and 11.2)*

Sl No.	Nominal Size	Diameter of Test Bar	Proof Torque	Load Position	Shock Load Dropped Through 600 mm at Point 'P'
	mm	mm	N-m	$L$	kg
(1)	(2)	(3)	(4)	(5)	(6)
i)	200	16	180	150	13
ii)	250	20	330	200	13
iii)	300	25	500	225	13
iv)	350	30	650	262	18
v)	450	40	1 000	362	18
vi)	600	52	1 450	500	22
vii)	900	75	2 350	762	27
viii)	1 200	100	3 250	1 025	27

ANNEX A

(Foreword)

COMMITTEE COMPOSITION

Hand Tools Sectional Committee, PGD 34

<i>Organization</i>	<i>Representatives(s)</i>
Institute for Auto Parts and Hand tools Technology, Ludhiana	SHRI SANJEEV KATOCH ( <b>Chairperson</b> )
Ajay Industries Private Limited, Jalandhar	SHRI AJAY GOSWAMI SHRI RAJAT GOSWAMI ( <i>Alternate</i> )
Bharat Heavy Electrical Limited, New Delhi	SHRI M. RAVI SHRI J. S. ROY ( <i>Alternate</i> )
Central Institute of Hand Tools, Jalandhar	SHRI AMIT KUMAR
Directorate General of Quality Assurance, Ministry of Defence, New Delhi	SHRI MANOJ PANDEY SHRI D. K. MOHAPATRA ( <i>Alternate</i> )
Engineering Export Promotion Council, New Delhi	SHRI OPINDER SINGH SHRI ASHWANI KUMAR ( <i>Alternate</i> )
Falcon Garden Tools Private Limited, Ludhiana	SHRI GURCHINTAN SINGH SHRI SURINDER PAL SINGH ( <i>Alternate</i> )
Gardex Industries, Jalandhar	SHRI PARAMJIT SINGH SHRI ASHUTOSH DATTA ( <i>Alternate</i> )
Gujarat Matikam Kalakari and Rural Technology Institute, Gandhinagar	SHRI K. R. DHALORIA SHRI SATENDRA PAL SINGH ( <i>Alternate</i> )
Hand Tools Industries Association, Nagaur	SHRI JULPHIKAR ALI SHRI ASHFAQ ALI ( <i>Alternate</i> )
Hand Tools Manufacturers Association, Jalandhar	SHRI SUKHDEV RAJ SHRI ASHWANI KUMAR ( <i>Alternate</i> )
Inder Industries, Jalandhar	SHRI VIJAY CHATRATH SHRI SUNIL CHATRATH ( <i>Alternate</i> )
Indian Oil Corporation Limited, New Delhi	MS NEETA AGARWAL SHRI ABHISHEK ANUPAM ( <i>Alternate</i> )
Institute for Auto Parts and Hand tools Technology, Ludhiana	MS SHIVANI THAKUR SHRI PANKAJ KAUNDAL ( <i>Alternate</i> )
Kudale Instruments Private Limited, Pune	SHRI PUTAMBEKAR C. M. SHRI SANGRAM KUDALE ( <i>Alternate</i> )
Ludhiana Hand Tools Association, Ludhiana	SHRI ASHOK GUPTA SHRI S. C. RALHAN ( <i>Alternate</i> )
Mekaster Tools Limited, Chennai	SHRI SALIL AGARWAL
Oaykay Forgings Private Limited, Jalandhar	SHRI SHARAD AGGARWAL
Office of Development Commissioner (MSME), New Delhi	SHRI K. L. RAO SHRI K. K. FUNDA ( <i>Alternate I</i> ) SHRI G. SHANMUGANATHAN ( <i>Alternate II</i> )



<i>Organization</i>	<i>Representatives(s)</i>
Osho Tools Private Limited, Jandiali	SHRI RAJESH PESHION SHRI ASHOK GUPTA ( <i>Alternate</i> )
Passi Agro-tech Enterprises, Ludhiana	SHRI BIKRAMJIT SINGH SHRI SARBAGH SINGH ( <i>Alternate</i> )
Pye Tools Private Limited, Ludhiana	SHRI GAURAV SEHGAL
Research Designs and Standards Organization (RDSO), Lucknow	EXECUTIVE DIRECTOR
Taparia Tools Limited, Nashik	SHRI NIKHIL BHUTUJA SHRI N. B. BORSE ( <i>Alternate</i> )
Tata Motors Limited, Pune	SHRI ANOOP TOBY SHRI HANAMANT GURAV ( <i>Alternate</i> )
Tata Steel Limited, Kolkata	SHRI RAHUL MISHRA SHRI JAYANT BHARDWAJ ( <i>Alternate</i> )
Victor Forgings, Jalandhar	SHRI ANIL KUMAR SHRI SUKHDEV RAJ ( <i>Alternate</i> )
BIS Directorate General	SHRI RAJEEV RANJAN SINGH, 'F'/SENIOR DIRECTOR AND HEAD (PRODUCTION AND GENERAL ENGINEERING) [REPRESENTING DIRECTOR GENERAL ( <i>Ex-officio</i> )]

*Member Secretary*  
SHRI VIMAL KUMAR  
SCIENTIST 'B'/ASSISTANT DIRECTOR  
(PRODUCTION AND GENERAL ENGINEERING), BIS





## Bureau of Indian Standards

BIS is a statutory institution established under the *Bureau of Indian Standards Act, 2016* to promote harmonious development of the activities of standardization, marking and quality certification of goods and attending to connected matters in the country.

### Copyright

BIS has the copyright of all its publications. No part of these publications may be reproduced in any form without the prior permission in writing of BIS. This does not preclude the free use, in the course of implementing the standard, of necessary details, such as symbols and sizes, type or grade designations. Enquiries relating to copyright be addressed to the Head (Publication & Sales), BIS.

### Review of Indian Standards

Amendments are issued to standards as the need arises on the basis of comments. Standards are also reviewed periodically; a standard along with amendments is reaffirmed when such review indicates that no changes are needed; if the review indicates that changes are needed, it is taken up for revision. Users of Indian Standards should ascertain that they are in possession of the latest amendments or edition by referring to the website-[www.bis.gov.in](http://www.bis.gov.in) or [www.standardsbis.in](http://www.standardsbis.in).

This Indian Standard has been developed from Doc No.: PGD 34 (20366).

### Amendments Issued Since Publication

Amend No.	Date of Issue	Text Affected

## BUREAU OF INDIAN STANDARDS

### Headquarters:

Manak Bhavan, 9 Bahadur Shah Zafar Marg, New Delhi 110002

Telephones: 2323 0131, 2323 3375, 2323 9402

Website: [www.bis.gov.in](http://www.bis.gov.in)

### Regional Offices:

	Telephones
Central : 601/A, Konnectus Tower -1, 6 <sup>th</sup> Floor, DMRC Building, Bhavbhuti Marg, New Delhi 110002	{ 2323 7617
Eastern : 8 <sup>th</sup> Floor, Plot No 7/7 & 7/8, CP Block, Sector V, Salt Lake, Kolkata, West Bengal 700091	{ 2367 0012 2320 9474
Northern : Plot No. 4-A, Sector 27-B, Madhya Marg, Chandigarh 160019	{ 265 9930
Southern : C.I.T. Campus, IV Cross Road, Taramani, Chennai 600113	{ 2254 1442 2254 1216
Western : 5 <sup>th</sup> Floor/MTNL CETTM, Technology Street, Hiranandani Gardens, Powai Mumbai 400076	{ 25700030 25702715

**Branches :** AHMEDABAD, BENGALURU, BHOPAL, BHUBANESHWAR, CHANDIGARH, CHENNAI, COIMBATORE, DEHRADUN, DELHI, FARIDABAD, GHAZIABAD, GUWAHATI, HARYANA (CHANDIGARH), HUBLI, HYDERABAD, JAIPUR, JAMMU, JAMSHEDPUR, KOCHI, KOLKATA, LUCKNOW, MADURAI, MUMBAI, NAGPUR, NOIDA, PARWANOO, PATNA, PUNE, RAIPUR, RAJKOT, SURAT, VIJAYAWADA.