

टॉल्युईन — विशिष्टि
(तीसरा पुनरीक्षण)

Toluene — Specification
(Third Revision)

ICS 75.080

© BIS 2024



भारतीय मानक ब्यूरो
BUREAU OF INDIAN STANDARDS
मानक भवन, 9 बहादुर शाह ज़फर मार्ग, नई दिल्ली - 110002
MANAK BHAVAN, 9 BAHADUR SHAH ZAFAR MARG
NEW DELHI - 110002
www.bis.gov.in www.standardsbis.in

FOREWORD

This Indian Standard (Third Revision) was adopted by the Bureau of Indian Standards, after the draft finalized by the Petroleum and their Related Products of Synthetic or Biological or Natural Origin Sectional Committee had been approved by the Petroleum, Coal and Related Products Division Council.

Toluene is used as a raw material in manufacture of alkylated, nitrated and halogenated organic intermediates for petrochemical dyestuffs and fine chemical industries. It is also used as a solvent in paint, coating, adhesive and ink formulations.

Toluene is derived by suitable fractionation of crude oil and refining by washing with acid or by hydro-refining of crude benzoyl recovered from the gas produced during carbonization of coal in coke ovens and retorts or recovered as by-products in petroleum refining or petrochemical operations.

This standard was first published in 1955 and was based on overseas national standards including the work accomplished till then by the Committee, ISO/TC 78 'Aromatic hydrocarbons' of the International Organization for Standardization (ISO).

First revision of the standard was published in 1967. In the first revision, toluene with especially low content of non-sulphonable hydrocarbons was covered. Besides, the requirement of distillation range was tightened in order to take care of the possibility of admixture with benzene. Colorimetric tests were also prescribed for acid wash test and colour.

Second revision of the standard was published in 2011. In the second revision, the requirements of residue on evaporation and corrosive sulphur were deleted, and gas chromatographic (GC) method was incorporated for determination of purity. Methods of test for distillation range and relative density were modified.

Earlier, toluene was essentially a coal base product which was being made available as by-product from coke ovens of steel plants. The requirements and methods of test were also stipulated on the basis of the publication by national benzoyl and allied products association (NBA) and the standardization of Tar Products Tests Committee (STPC), U.K., in order to suit the prevailing quality of the product. However, during second revision, the Committee took cognizance of the fact that consequent upon exploration of oil fields, especially the Bombay High, substantial quantities of crude was available in the country which completely changed the scenario.

There was a distinct shift in the production of various aromatic hydrocarbons from coal base to petroleum base, as a result of which toluene was available in abundance. The toluene derived from petroleum was more suitable for various purposes as compared to that which was derived from coal.

The Committee also observed that this standard covers the requirements of reagent grade toluene, hence IS 1839 : 1961 "Toluene, reagent grade" was withdrawn.

In this revision, following major changes have been made:

- a) New instrumental test methods have been added as the refining industry in India have upgraded their testing methods in conformance to International Standards;
- b) Significance of tests has been added;
- c) Requirement of thiophene and H₂S/SO₂ has been removed as this requirement is deleted from international specification of toluene;
- d) The purity, Pt-Co colour, and non-aromatics specifications have been modified in line with international specifications with addition of acid wash colour; and
- e) Distillation test has been made optional as vapor generation is maximum during distillation test and inhalation of benzene/toluene vapors may be detrimental to health of testing personnel. Toluene purity is an essential requirement of the standard; hence distillation test may be kept optional.

(Continued on third cover)

Indian Standard
TOLUENE — SPECIFICATION
(Third Revision)

1 SCOPE

This standard prescribes the requirements and the methods of sampling and test for toluene.

2 REFERENCES

The standards given in [Annex A](#) contain provisions which, through reference in the text, constitute provisions of this standard. At the time of publication, the editions indicated were valid. All standards are subject to revision and parties to agreements based on this standard are encouraged to investigate the possibility of applying the most recent edition of these standards.

3 REQUIREMENTS

The material shall comply with the requirements given in [Table 1](#).

4 PACKING AND MARKING**4.1 Packing**

4.1.1 The material shall be packed as agreed to between the purchaser and the supplier.

4.1.2 All the containers in which the material is packed shall be dry, clean, leak proof, and free from substances soluble in toluene.

4.1.3 The containers shall be securely closed, protected from light, and shall be stored in a cool place.

4.1.4 As the material is classified as flammable and dangerous goods, the containers for storage and transport of the material, shall, in addition, comply with the requirements of the latest issue of red tariff and the requirements as laid down from time to time by the chief controller of explosives, government of India, for packing, storage, and transit of flammable liquids and the board of trade regulations as applicable therein for transport by steamers.

4.1.5 Necessary safeguards against the risk arising from the storage and handling of large volumes of flammable liquids (*see* IS 1446) shall be provided and all due precautions shall be taken [*see* IS 1260 (Part 1)] at all times to prevent accidents by fire or explosion.

4.1.6 Except when they are opened for the purpose of cleaning and rendering them free from toluene vapour, all empty tanks or other containers shall be kept securely closed unless they have been cleaned and freed from toluene vapour.

4.2 Marking

4.2.1 Each container shall be marked with the following information:

- a) Name of the material;
- b) Name of the manufacturer and recognized trademark, if any;
- c) Net mass of the material in the container;
- d) Identification in code or otherwise to enable the lot to be traced back from records;
- e) Date or year of manufacture/packing; and
- f) Any other statutory requirements.

4.2.2 Each container shall have the caution label 'FLAMMABLE' together with the corresponding symbol for labelling of dangerous goods as given in IS 1260 (Part1).

4.2.3 BIS Certification Marking

The product(s) conforming to the requirements of this standard may be certified as per the conformity assessment schemes under the provisions of the *Bureau of Indian Standards Act, 2016* and the Rules and Regulations framed thereunder, and the products may be marked with the Standard Mark.

5 HANDLING

Toluene is toxic and therefore it shall be handled carefully. Exposure of toluene in atmosphere should be monitored regularly. Persons exposed to toluene shall be periodically checked according to factory rules and local state regulations (*see* IS 4644).

6 SAMPLING

Representative samples of the material shall be prepared as prescribed in [Annex E](#).

7 TEST METHODS

Tests shall be conducted according to the methods prescribed in col (4) of [Table 1](#).

7.1 Quality of Reagents

Unless otherwise specified, pure chemicals and distilled water (see IS 1070) shall be employed in tests.

NOTE — 'Pure chemicals' shall mean chemicals that do not contain impurities, which affect the results of analysis.

Table 1 Requirements for Toluene
(Clauses [3](#), [7](#), [E-5.1.2](#), [E-5.2](#), [E-6.1.1](#), [E-6.1.2](#), [E-6.2](#) and [Foreword](#))

Sl No.	Characteristic	Requirement	Methods of Test, Ref to
(1)	(2)	(3)	(4)
(i)	Toluene, percent by mass, <i>Min</i>	99.7	ASTM D7504
(ii)	Appearance	Clear liquid free from sediment and haze when observed at 18.3 °C to 25.6 °C	Visual
(iii)	Colour, platinum-cobalt scale, <i>Max</i>	20	IS 1448 (Part 178)
(iv)	Relative density at 15.56 °C/15.56 °C or Density, 20 °C, g/ml	0.869 to 0.873 0.865 to 0.870	IS 1448 (Part 167) ¹ / Annex B
(v)	Total sulphur, mg/kg, <i>Max</i>	As agreed between purchaser and supplier	IS 1448 (Part 160) ¹ / IS 1448 (Part 161)/ Annex C
(vi)	Distillation Range (1 percent to 96 percent volume) including the temperature 110.6 °C at 101.3 kPa (760 mm of Hg pressure) ² , °C, <i>Max</i>	1	Annex D
(vii)	Non-aromatic hydrocarbons, percent by mass, <i>Max</i>	0.30	ASTM D7504
(viii)	Benzene content, percent by mass, <i>Max</i>	0.05	
(ix)	Water content, mg/kg, <i>Max</i>	500	IS 1448 (Part 175)/ IS 1448 (Part 182) ¹
(x)	Acid wash colour	Passes with 2	Relevant Annex of IS 534

¹In case of disputes, this method shall be the referee method.

²Distillation test is optional.

ANNEX A

(Clause 2)

LIST OF REFERRED STANDARDS

<i>IS No./Other Standard</i>	<i>Title</i>	<i>IS No./Other Standard</i>	<i>Title</i>
IS 534 : 2021	Benzene — Specification (<i>fifth revision</i>)	(Part 175) : 2020/ ISO 6296 : 2000	Petroleum products — Determination of water — Potentiometric karl — Fischer titration method
IS 1070 : 2023	Reagent grade water (<i>fourth revision</i>)	(Part 178) : 2020/ ISO 6271 : 2015	Clear liquids — Estimation of colour by the platinum cobalt colour scale
IS 1260 (Part 1) : 1973	Pictorial marking for handling and labeling of goods: Part 1 Dangerous goods (<i>first revision</i>)	(Part 182) : 2020/ ISO 12937 : 2000	Petroleum products — Determination of water — Coulometric karl fischer titration method
IS 1446 : 2002	Classification of dangerous goods (<i>second revision</i>)	IS 4644 : 1968	Code of safety for benzene, toluene and xylene
IS 1448	Methods of test for petroleum and its products:	IS 4905 : 2015	Random sampling and randomization procedure (<i>first revision</i>)
(Part 160) : 2017/ ISO 20846 : 2011	Determination of sulphur content of automotive fuels — Ultraviolet fluorescence method	IS 5165 : 2017/ ISO 383 : 1976	Laboratory glassware — Interchangeable conical ground joints (<i>first revision</i>)
(Part 161) : 2017/ ISO 13032 : 2012	Determination of low concentration of sulphur in automotive fuels — Energy dispersive X-ray fluorescence spectrometric method	ASTM D7504-23	Standard test method for trace impurities in monocyclic aromatic hydrocarbons by gas chromatography and effective carbon number
(Part 167) : 2018/ ISO 12185 : 1996	Determination of density — Oscillating U-tube method		

To access Indian Standards click on the link below:

https://www.services.bis.gov.in/php/BIS_2.0/bisconnect/knowyourstandards/Indian_standards/isdetails/

ANNEX B

[Table 1, Sl No (iv)]

DETERMINATION OF DENSITY OR RELATIVE DENSITY

B-1 GENERAL

Pyknometer method for determination of density or relative density is specified.

B-2 SIGNIFICANCE

Density is a fundamental physical property that can be used in conjunction with other properties to characterize both the light and heavy fractions of petroleum and petroleum products. It is used for calculating the mass when volume is known and for the conversion of measured volumes to volumes at the standard temperature of 15 °C. It is also used to identify the stream/product to some extent. Though it gives a very uncertain indication of the fuel quality, density can indicate gross contamination increase, if any. This property can also be used as an indication whether the product has been contaminated during the movement.

B-3 PYKNOMETER METHOD**B-3.1 Outline of the Pyknometer Method**

For materials given in [Table 2](#), the sample is drawn into a weighed and calibrated bicapillary pyknometer. The filled pyknometer is allowed to come to equilibrium at any convenient temperature between 10 °C and 30 °C. The equilibrium temperature is measured to the nearest 0.02 °C. The weight is determined by using a beam balance. The density, relative density, or commercial density at the desired reference temperature is then calculated from the sample weight, a calibration factor proportional to an equal volume of water, and a multiplier which corrects for the buoyancy of air and the change in volume of the pyknometer and the sample due to deviation from the chosen reference temperature.

B-3.2 Apparatus**B-3.2.1 Pyknometer**

9 ml to 10 ml capacity, conforming to the dimensions given in [Fig. 1](#), constructed of borosilicate glass, and having a total weight not exceeding 30 g.

B-3.2.3 Bath Thermometer — Capable of measuring temperature in the range of – 8 °C to + 32 °C.

B-3.3 Preparation of Apparatus**B-3.3.1 Acid Cleaning**

When liquid fails to drain cleanly from the walls of the pyknometer or its capillary, clean with hot chromic acid solution thoroughly and rinse well with water. Dry at 105 °C to 110 °C for at least 1 h, preferably with a slow current of filtered air passing through the pyknometer.

B-3.3.2 Solvent Cleaning

For use between determinations, rinse with toluene and then with anhydrous acetone, drying with a filtered stream of dry air.

B-3.4 Calibration of Apparatus

B-3.4.1 Using the procedure described in [B-3.5](#), determine the weight of freshly boiled reagent water held by the pyknometer with the water level at each of three different scale points on the graduated arms. Make all weighings on the same day, using the same balance and weights.

B-3.4.2 Calculate the volume, V_T^P , at each scale point tested by means of the following equation, carry all calculations in 6 non-zero digits and round to 4 decimal places:

$$\text{Pyknometer capacity, } V_T^P, \text{ ml} = A \times \left(\frac{W^W}{d_t^W} \right) + B \times (T - t)$$

where

V_T^P = volume, in ml, of pyknometer at reference temperature, T ;

A = air buoyancy coefficient, in g, a constant for the temperature range involved = 1.001 064; W^W = Weight of water in air, contained in the pyknometer;

d_t^W = density of water at t (see [Table 3](#));

B = volumetric coefficient of expansion of 9.5 ml of a borosilicate glass pycnometer = 9.26276×10^{-5} ml/°C.

T = reference temperature, 20 °C or 15.56 °C; and

B-3.4.3 Prepare a calibration curve by plotting apparent volume, V_A (the sum of the scale readings on the two arms of the pycnometer) against the corresponding calculated volume, V_T^P . If a straight line cannot be drawn through the three points, discard the data and determine three additional points so that a straight calibration line can be drawn, such that no data point lies more than 0.000 2 ml units from the line. If neither set of data meets the condition, the diameters of the graduated capillary arms are not sufficiently uniform, and the pycnometer shall be discarded.

B-3.4.4 From the curve obtained, prepare a table of apparent volume, V_A (sum of scale readings of both arms), as apparent volume against corresponding calculated volumes, V_T^P , in increments of 0.000 1 ml. Label [Table 3](#) with the reference temperature to which it applies.

B-3.5 Procedure

B-3.5.1 Weigh the clean, dry pycnometer to 0.1 mg and record the weight.

B-3.5.2 With the sample at approximately the test temperature, fill the pycnometer by holding it in an upright position and placing the hooked tip in the sample; the liquid will then be drawn over the bend in the capillary by surface tension. Allow the pycnometer to fill by siphoning (about 1 min) and break the siphon when the liquid level in the bulb arm of the pycnometer reaches the lowest graduation mark.

B-3.5.3 Thoroughly dry the wet tip. Wipe the body of the pycnometer with a chemically clean, lint-free cloth slightly damp with water (*see Note*) and weigh the filled pycnometer to the nearest 0.1 mg.

NOTE — In atmospheres below 60 percent relative humidity, drying the pycnometer by rubbing with a dry cotton cloth will induce static charges equivalent to a loss

of about 1 mg or more in the weight of the pycnometer. This charge may not be completely dissipated in less than 30 min, and can be detected by touching the pycnometer to the wire hook in the balance and then drawing it away slowly. If the pycnometer exhibits an attraction for the wire hook, it may be considered to have a static charge.

B-3.5.4 Place the pycnometer in the holder in a constant temperature bath held at any convenient temperature between 10 °C and 30 °C within ± 0.02 °C. When the liquid level has reached temperature equilibrium (usually in about 10 min) and while still in the water bath, read the scale to the nearest 0.2 small divisions at the liquid level in each arm.

B-3.6 Calculation

Compute the density or relative density, or both, by means of the following equations:

$$\text{Density, g/ml at } 20\text{ }^\circ\text{C} = (W^S/V_{20}^P) \times F_{20} + 0.001\ 21$$

$$\text{Relative density at } 20/20\text{ }^\circ\text{C} = [(W^S/V_{20}^P) \times F_{20} + 0.001\ 21] \times 1.000\ 96$$

where

W^S = observed weight of sample, in g, corrected for variation of weights;

V_{20}^P = calculated volume, in ml, V_T^P of sample at 20 °C obtained from the pycnometer calibration table; and

F_{20} = constants taken from [Table 2](#), corresponding to the test temperature.

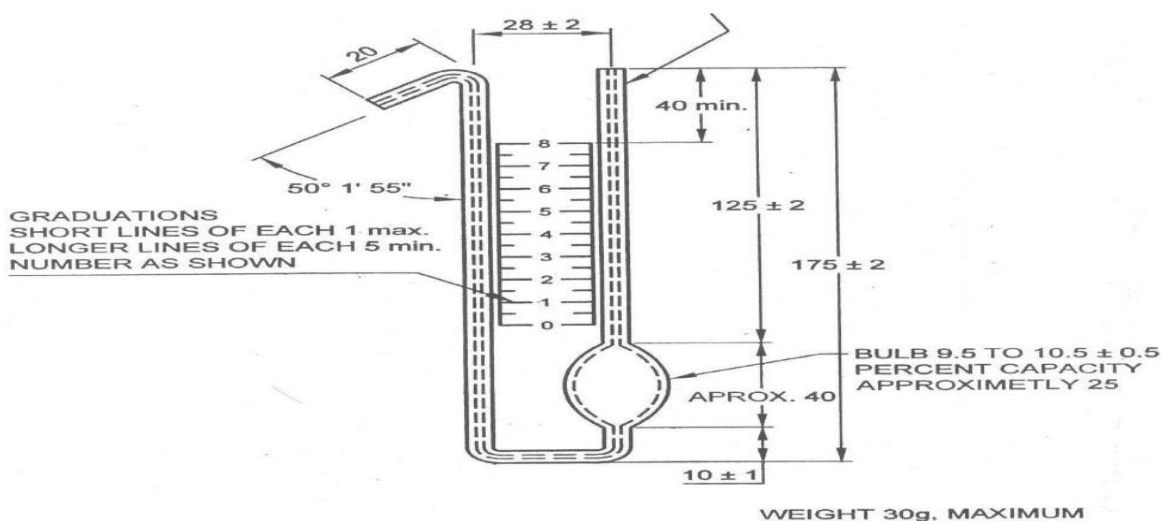

All dimensions in millimeters.

FIG. 1 PYCNOMETER

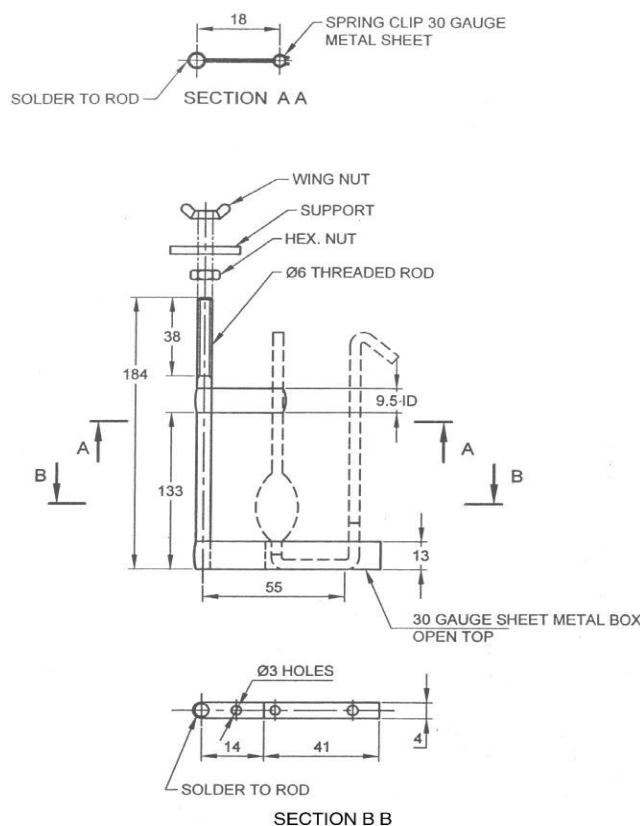

All dimensions in millimetres.

FIG. 2 PYKNOMETER HOLDER

Table 2 20 °C Reference Temperature Multiplier, F_{20} , for Use in Computing Density
(Clauses B-3.1 and B-3.6)

Sl. No.	Temperature, °C	Benzene	Toluene	Mixed Xylenes	o-xylene	m-xylene	p-xylene
(1)	(2)	(3)	(4)	(5)	(6)	(7)	(8)
i)	10	0.988 22	0.989 41	0.990 28	0.990 52	0.990 28	0.990 11
ii)	10.2	0.988 45	0.989 62	0.990 47	0.990 7	0.990 47	0.990 3
iii)	10.4	0.988 65	0.989 83	0.990 66	0.990 89	0.990 66	0.990 49
iv)	10.6	0.938 91	0.990 03	0.990 85	0.991 07	0.990 85	0.990 69
v)	10.8	0.989 14	0.990 24	0.991 04	0.991 26	0.991 04	0.990 66
vi)	11	0.989 37	0.990 4	0.991 23	0.99144	0.991 23	0.991 07
vii)	11.2	0.989 6	0.990 66	0.991 42	0.991 63	0.991 42	0.991 26
viii)	11.4	0.989 62	0.990 36	0.991 61	0.991 81	0.991 61	0.991 46
ix)	11.6	0.990 05	0.991 07	0.991 79	0.992	0.991 79	0.991 65
x)	11.8	0.990 28	0.991 28	0.991 98	0.992 18	0.991 98	0.991 84
xi)	12	0.990 51	0.991 48	0.992 17	0.992 37	0.992 17	0.992 04
xii)	12.2	0.990 74	0.991 69	0.992 36	0.992 55	0.992 36	0.992 23
xiii)	12.4	0.990 97	0.991 9	0.992 55	0.992 74	0.992 53	0.992 42
xiv)	12.6	0.991 20	0.992 11	0.992 74	0.992 92	0.992 74	0.992 62
xv)	12.8	0.991 44	0.992 31	0.992 93	0.993 11	0.992 93	0.992 81
xvi)	13	0.991 67	0.992 52	0.993 12	0.993 29	0.993 12	0.993 00

Table 2 (Continued)

Sl. No.	Temperature, °C	Benzene	Toluene	Mixed Xylenes	o-xylene	m-xylene	p-xylene
(1)	(2)	(3)	(4)	(5)	(6)	(7)	(8)
xvii)	13.2	0.991 90	0.992 73	0.993 31	0.993 48	0.993 31	0.993 20
xviii)	13.4	0.992 13	0.992 94	0.993 5	0.993 67	0.993 5	0.993 39
xix)	13.6	0.992 36	0.993 15	0.993 69	0.993 85	0.993 69	0.993 58
xx)	13.8	0.992 59	0.993 35	0.993 89	0.994 04	0.993 89	0.993 78
xxi)	14	0.992 82	0.993 56	0.994 08	0.994 22	0.994 08	0.993 97
xxii)	14.2	0.993 05	0.993 77	0.994 27	0.994 41	0.994 27	0.994 17
xxiii)	14.6	0.993 53	0.994 19	0.994 64	0.994 78	0.994 65	0.994 56
xxiv)	14.8	0.993 75	0.994 4	0.994 84	0.994 97	0.994 84	0.994 75
xxv)	15	0.993 98	0.994 41	0.995 03	0.995 16	0.995 03	0.994 95
xxvi)	15.2	0.994 21	0.994 81	0.995 22	0.995 34	0.995 22	0.995 14
xxvii)	15.4	0.994 45	0.995 02	0.995 41	0.995 53	0.995 41	0.995 34
xxviii)	15.6	0.994 68	0.995 23	0.995 61	0.995 72	0.995 61	0.995 53
xxix)	15.8	0.994 91	0.995 44	0.995 8	0.995 9	0.995 80	0.995 73
xxx)	16	0.995 15	0.995 65	0.995 99	0.996 09	0.995 99	0.995 92
xxxi)	16.2	0.995 38	0.995 86	0.99618	0.996 28	0.996 18	0.996 12
xxxii)	16.4	0.995 61	0.996 07	0.996 37	0.996 46	0.996 37	0.996 31
xxxiii)	16.6	0.995 85	0.996 28	0.996 57	0.996 65	0.996 57	0.996 51
xxxiv)	16.8	0.996 08	0.996 49	0.996 76	0.996 84	0.996 76	0.996 70
xxxv)	17	0.996 32	0.996 70	0.996 95	0.997 03	0.996 95	0.996 9
xxxvi)	17.2	0.996 55	0.996 91	0.997 14	0.997 21	0.997 14	0.997 10
xxxvii)	17.4	0.996 79	0.997 12	0.997 34	0.997 4	0.997 34	0.997 29
xxxviii)	17.6	0.997 02	0.997 33	0.997 53	0.997 59	0.997 53	0.997 49
xxxix)	17.8	0.997 26	0.997 54	0.997 72	0.997 78	0.997 72	0.997 68
xl)	18	0.997 49	0.997 75	0.997 91	0.997 97	0.997 91	0.997 88
xli)	18.2	0.997 73	0.997 96	0.998 11	0.998 15	0.998 11	0.998 08
xl ii)	18.4	0.997 96	0.998 17	0.998 30	0.998 34	0.998 30	0.993 27
xl iii)	18.6	0.998 2	0.998 38	0.998 49	0.998 53	0.998 49	0.998 47
xl iv)	18.8	0.998 43	0.998 59	0.998 69	0.998 72	0.998 69	0.998 67
xl v)	19	0.998 67	0.998 80	0.998 88	0.998 91	0.998 88	0.998 86
xl vi)	19.2	0.998 9	0.999 01	0.999 07	0.999 10	0.999 07	0.999 06
xl vii)	19.4	0.999 14	0.999 22	0.999 27	0.999 28	0.999 27	0.999 26
xl viii)	19.6	0.999 38	0.999 43	0.999 46	0.999 47	0.999 44	0.999 46
xl ix)	19.8	0.999 61	0.999 64	0.999 66	0.999 66	0.999 66	0.999 65
l)	20	0.999 85	0.999 85	0.999 85	0.999 85	0.999 85	0.999 85
li)	20.2	1.000 09	1.000 06	1.000 04	1.000 04	1.000 04	1.000 05
li i)	20.4	1.000 32	1.000 27	1.000 24	1.000 23	1.000 24	1.000 25
li ii)	20.6	1.000 56	1.000 48	1.000 43	1.000 42	1.000 43	1.000 44
li v)	20.8	1.000 8	1.000 69	1.000 63	1.000 61	1.000 03	1.000 64
li v)	21	1.001 04	1.000 91	1.000 82	1.000 8	1.000 82	1.000 84
li vi)	21.2	1.001 28	1.001 12	1.001 02	1.000 99	1.00102	1.001 04
li vii)	21.4	1.001 51	1.001 33	1.001 21	1.001 18	1.001 21	1.001 24
li viii)	21.6	1.001 75	1.001 54	1.001 41	1.001 37	1.001 41	1.001 43
li x)	21.8	1.001 99	1.001 75	1.001 60	1.001 56	1.001 6	1.001 63
li x)	22	1.002 23	1.001 96	1.001 8	1.001 75	1.001 80	1.001 63
li xi)	22.2	1.002 47	1.002 18	1.001 99	1.001 94	1.001 99	1.002 03

Table 2 (Concluded)

Sl. No.	Temperature, °C	Benzene	Toluene	Mixed Xylenes	o-xylene	m-xylene	p-xylene
(1)	(2)	(3)	(4)	(5)	(6)	(7)	(8)
lxii)	22.4	1.002 71	1.002 39	1.002 19	1.002 13	1.002 19	1.002 23
lxiii)	22.6	1.002 95	1.002 60	1.002 38	1.002 32	1.002 38	1.002 43
lxiv)	22.8	1.003 19	1.002 81	1.002 58	1.06251	1.002 53	1.002 63
lxv)	23	1.003 42	1.003 02	1.002 711	1.002 70	1.002 78	1.002 33
lxvi)	23.2	1.003 66	1.003 24	1.002 97	1.002 89	1.002 97	1.003 03
lxvii)	23.4	1.003 9	1.003 45	1.003 17	1.003 08	1.003 17	1.003 22
lxviii)	23.6	1.004 14	1.003 66	1.003 36	1.003 27	1.003 36	1.003 42
lxix)	23.8	1.004 38	1.003 87	1.003 56	1.003 46	1.003 56	1.003 62
lxx)	24	1.004 62	1.004 09	1.003 76	1.003 65	1.003 76	1.003 82
lxxi)	24.2	1.004 87	1.004 3	1.003 95	1.003 84	1.003 95	1.004 02
lxxii)	24.4	1.005 11	1.004 51	1.004 15	1.004 03	1.004 15	1.004 72
lxxiii)	24.6	1.005 35	1.004 13	1.004 35	1.004 22	1.004 35	1.004 42
lxxiv)	24.8	1.005 59	1.00494	1.004 54	1.004 42	1.004 54	1.004 62
lxxv)	25	1.005 83	1.005 15	1.004 74	1.004 61	1.004 74	1.004 82
lxxvi)	25.2	1.005 07	1.005 37	1.004 94	1.004 8	1.004 94	1.005 02
lxxvii)	25.4	1.006 31	1.005 58	1.005 14	1.004 99	1.005 14	1.005 22
lxxviii)	25.6	1.006 56	1.005 79	1.005 33	1.005 18	1.005 33	1.005 42
lxxix)	25.8	1.006 8	1.006 01	1.005 53	1.995 37	1.005 53	1.005 63
lxxx)	26	1.007 04	1.006 22	1.005 73	1.005 57	1.005 13	1.005 83
lxxxii)	26.2	1.007 28	1.006 43	1.005 93	1.005 76	1.005 93	1.006 03
lxxxiii)	26.4	1.007 53	1.006 65	1.006 12	1.005 95	1.006 12	1.006 23
lxxxiv)	26.6	1.007 77	1.006 86	1.006 32	1.006 14	1.006 32	1.006 43
lxxxv)	26.8	1.008 01	1.007 07	1.006 52	1.006 34	1.006 52	1.006 63
lxxxvi)	27	1.008 25	1.007 29	1.006 72	1.006 53	1.006 72	1.006 83
lxxxvii)	27.2	1.008 5	1.007 50	1.006 92	1.006 72	1.006 92	1.007 03
lxxxviii)	27.4	1.008 74	1.007 72	1.007 11	1.006 91	1.007 11	1.007 24
lxxxix)	27.6	1.008 99	1.007 93	1.007 31	1.007 11	1.007 31	1.007 44
xc)	28	1.009 47	1.008 36	1.007 71	1.007 49	1.007 71	1.007 84
xcii)	28.2	1.009 72	1.008 58	1.007 91	1.007 69	1.007 91	1.008 04
xciii)	28.4	1.009 96	1.008 79	1.008 11	1.007 88	1.008 11	1.008 25
xciv)	28.6	1.010 21	1.009 01	1.008 31	1.008 07	1.008 31	1.008 45
xcv)	28.8	1.010 45	1.009 22	1.008 51	1.008 27	1.008 51	1.008 65
xcvi)	29	1.010 7	1.009 44	1.008 71	1.008 46	1.008 71	1.008 85
xcvii)	29.2	1.010 94	1.009 65	1.908 91	1.008 66	1.008 91	1.009 06
xcviii)	29.4	1.011 19	1.009 87	1.009 11	1.008 85	1.009 11	1.009 26
xcix)	29.6	1.011 43	1.010 08	1.009 31	1.009 04	1.009 31	1.009 46
c)	29.8	1.011 68	1.010 3	1.009 51	1.009 24	1.009 51	1.009 66
c)	30	1.011 92	1.010 51	1.009 71	1.009 43	1.009 71	1.009 87

NOTE — Choose a multiplier for the material being measured corresponding to the bath temperature at which the pycnometer is equilibrated.

Table 3 Density of Water, g/ml*(Clauses [B-3.4.2](#) and [B-3.4.4](#))*

Sl No.	$t, ^\circ\text{C}$	0.0	0.1	0.2	0.3	0.4	0.5	0.56	0.6	0.7	0.8	0.9	
(1)	(2)	(3)	(4)	(5)	(6)	(7)	(8)	(9)	(10)	(11)	(12)	(13)	(14)
i)	15	0.999	13	11	10	08	07	05	04	04	02	00	99
ii)	16	0.998	97	96	94	92	91	89		87	86	84	82
iii)	17		80	79	77	75	73	72		70	68	66	64
iv)	18		62	61	89	57	55	53		51	49	47	45
v)	19		42	42	40	38	36	34		32	30	27	25
vi)	20		23	21	19	17	15	13		11	09	07	04
vii)	21		02	00	98	96	93	91		89	87	85	82
viii)	22	0.997	80	78	75	73	71	69		66	64	62	59
ix)	23		57	64	52	50	47	45		42	40	38	35
x)	24		33	30	28	25	23	20		18	15	13	10
xi)	25		08	05	02	00	97	95		92	89	87	84
xii)	26	0.996	81	79	76	73	71	68		65	63	60	57
xiii)	27		54	52	49	46	43	41		38	35	32	29
xiv)	28		26	24	21	18	15	12		09	06	03	00
xv)	29	0.995	98	95	92	89	86	83		80	77	74	72
xvi)	30		68	65	62	59	56	53		50	46	43	40

ANNEX C

[Table 1, Sl No. (v)]

DETERMINATION OF TOTAL SULPHUR CONTENT

C-1 OUTLINE OF THE METHOD

The sample is reacted with Raney nickel. The hydrogen sulphide liberated from the nickel sulphide thus formed is absorbed and titrated with mercuric acetate. Certain oxygenated sulphur compounds are not completely determined and some olefins interfere with the test.

NOTE — Stringent precautions shall be taken to avoid sulphur contamination from atmosphere, apparatus, and reagents or other sources. Care should be taken not to allow sodium hydroxide reagent or apparatus 'wet' with this reagent to be exposed to laboratory atmosphere.

C-2 APPARATUS**C-2.1 Reduction Apparatus**

The reduction apparatus shall be of the shape, dimensions and assembly as shown in [Fig. 3](#). The cone and delivery tube is connected to a supply of nitrogen via a dreschel bottle and the luted venting device. Rubber tubing shall not be used for nitrogen supply connection; PVC or other sulphur-free plastics tubing is suitable. The 100-ml flask is heated electrically by means of a mantle. The apparatus consists of the following:

C-2.1.1 Reduction Flask

100 ml round-bottomed flask with two short upright necks having respectively 10/19 and 14/23 ground-glass sockets (*see* IS 5165). The flask is also fitted with a 10/19 ground-glass socket inclined to centre-bottom.

C-2.1.2 Glass Delivery Tube

A 10/19 (*see* IS 5165) cone and stem with the end drawn out to a 1 mm hole, of such a length that the tip is within 5 mm of the centre of the bottom of the flask when the cone is in position in the inclined socket.

C-2.1.3 Tap Funnel — Capacity 20 ml with 10/19 cone and socket (*see* IS 5165).

C-2.1.4 Adaptor — Right-angle connection with 10/19 cone.

C-2.1.5 Condenser

A Liebig condenser, effective length 150 mm, with a 14/23 cone and socket.

C-2.1.6 Absorber

A delivery tube of (6 mm ± 0.5 mm) outer diameter bent at 110° and containing a small expansion chamber in the upright section. The lower end of the tube has a 1 mm hole, and fits into a covered 200 mm x 32 mm outer diameter boiling tube. The upper end of the delivery tube is bent at an angle of 70° and fitted with a 14/23 cone at a distance of approximately 135 mm from the longer arm.

C-2.1.7 Gas Washing Bottle — Dreschel bottle having a dip-tube of about 6 mm outer diameter.

C-2.1.8 Microburette — Capacity 10 ml arranged so that the liquid in the absorber can be titrated.

C-2.2 Flask

A 500 ml stoppered conical flask, marked at the 400 ml level with the cone and stopper lubricated with silicone grease.

C-2.3 Measuring Cylinder, capacity 10 ml.**C-2.4 Pipette**

C-2.5 Thermometer — Any suitable thermometer including the interval 75 °C to 80 °C.

C-3 REAGENTS**C-3.1 Acetone****C-3.2 Propan-2-ol****C-3.3 Nitrogen**

C-3.4 Raney Nickel — A 1:1 mixture of nickel and aluminium.

C-3.5 Sodium Hydroxide Solutions, 2.5 N and 1 N

Clean the conical flask with nitric acid/potassium dichromate mixture [prepared by dissolving 5 g of potassium dichromate in 5 ml of water and adding 100 ml of concentrated (15 N) nitric acid, stirring continuously] and rinse thoroughly with water. Fill with water to the 400 ml mark and add the mass of sodium hydroxide pellets appropriate for preparation of the 2.5 N or 1 N solution. Swirl gently until dissolution is complete and allow to cool.

C-3.6 Hydrochloric Acid, 5N

C-3.7 Potassium Hydroxide — 40 g/l solution in ethanol.

C-3.8 Mercuric Acetate Solution

Dissolve 0.675 g of mercuric oxide, previously dried at 100 °C, in 50 ml of water containing 2 ml of glacial (17 M) acetic acid. Dilute to 1 000 ml with water and mix well. Dilute 50 ml of the solution thus prepared to 250 ml with water and mix well. One milliliter of the diluted solution is equivalent to 0.02 mg of sulphur.

C-3.9 Dithizone Indicator Solution — 1 g/l in acetone, prepared fresh daily, or every 3 days, if stored in a refrigerator.

NOTE — When experience has been gained with the concentration of indicator required, a few grains of the solid indicator may be added to the absorber. In this way any instability of indicator solution is overcome.

C-4 PROCEDURE

C-4.1 Clean the apparatus thoroughly with a mixture of nitric acid and potassium dichromate. Rinse thoroughly with water and acetone and dry in an oven which has not been contaminated with sulphur or sulphur containing materials in previous use. The apparatus is self-scouring and, when in constant use, shall not be cleaned between determinations, except for rinsing the flask, delivery tube, absorber and thermometer with water. When not in constant use, it shall be cleaned between determinations with water and acetone.

NOTE — For activating nickel perfectly, the weighed raney nickel is kept in caustic solution for at least 4 h.

C-4.2 Weigh accurately about 0.5 g of Raney nickel and put it in the reduction flask using a cone made from glazed paper, and add 10 ml of sodium hydroxide solution (2.5 N) from the measuring cylinder. Care shall be taken at this stage because there is a vigorous reaction.

C-4.3 When the reaction has subsided, swirl the liquid in the flask to bring the nickel adhering to the sides of the flask to the bottom. Set the flask aside for 10 min and then decant the supernatant liquid. Wash down both necks of the flask with 10 ml to 15 ml of water. Swirl the water vigorously to disturb the nickel residue, but avoid entrainment of air and, with minimum delay for settling, decant the water as completely as possible without too much attention to removing the last drop. Repeat the water wash three more times, and follow with a wash with 10 ml of propan-2-ol. Decant most of the propan-2-ol leaving enough to cover the catalyst, and add a further 10 ml of propan-2-ol.

NOTE — Incrustations around the stoppers and necks of sodium hydroxide bottles contain sufficient quantities of sulphur to affect test results. Such incrustations should be removed without allowing material to fall into the bottle. Before using solution from the bottle, pour a little to waste. Replace the stopper promptly.

C-4.4 Assemble the apparatus except for the tap funnel, lightly greasing all the joints with silicone grease. Add 50 ml of a mixture of equal parts of sodium hydroxide solution (1 N) and acetone to the boiling tube and add 5 drops of the dithizone indicator solution.

C-4.4.1 Calculate the appropriate size of sample as follows:

100 ml/specified or expected sulphur content in mg/kg.

Subject to a maximum of 50 ml, pipette the volume calculated above into the flask through the 10/19 socket.

C-4.5 Complete the assembly of the apparatus. Measure 10 ml of the hydrochloric acid solution into the tap funnel. Pass nitrogen at the rate of 2 or 3 bubbles/second as shown in the dreschel bottle containing the ethane-di-ol potassium hydroxide solution. Note the burette reading and titrate the contents of the absorber with the mercuric acetate solution to a pale pink colour.

C-4.5.1 Heat the flask at such a rate that the contents boil gently in about 10 min. Maintain the heating for a further period of 30 min at such a rate that small bubbles rise copiously from the nickel and gentle refluxing occurs.

C-4.5.2 Increase the input to the heating mantle slightly and allow the hydrochloric acid solution to drip slowly (10 ml in 5 min to 10 min) into the flask. Vigorous generation of hydrogen will occur, but little or no hydrogen sulphide will be evolved until about half the hydrochloric acid has entered the flask. Titrate the absorbing solution to a pink colour. As hydrogen sulphide is evolved and absorbed and the colour of the absorbing solution reverts to yellow, titrate in more mercuric acetate solution in order to restore the pink colour. After the addition of the acid, open the tap of the funnel occasionally to sweep forward any hydrogen sulphide that may have collected below it. When the evolution of hydrogen sulphide has almost ceased, increase the nitrogen flow rate to about 5 bubbles/second in the bottle to improve the transfer of hydrogen sulphide to the absorber.

C-4.5.3 When the evolution of hydrogen sulphide has apparently ceased, turn off the nitrogen temporarily and cool the flask by reducing the heat input and by blowing a little air on to it or by applying a damp cloth. The reduction

in pressure will cause the absorbing solution to rise up the delivery tube. Restore the nitrogen flow before the absorbing solution reaches the bend above the cone. Repeat this operation at about 2 min intervals until no more hydrogen sulphide is washed down. If any liquid enters the cone, the test shall be abandoned.

C-4.5.4 Boil the contents of the flask vigorously and continue the titration to the end point.

C-4.5.5 Carry out a blank test on the reagents omitting the sample. Once a day is normally sufficient but the blank shall always be re-determined, if there is any change in the reagents, apparatus, or laboratory atmosphere which could conceivably affect the blank value. This value should not exceed 0.6 ml.

C-5 CALCULATION

$$\text{Total sulphur content, mg/kg} = \frac{20 \times (V_1 - V_2)}{V \times D}$$

where

- V_1 = volume, in ml, of mercuric acetate solution used for the sample titration;
- V_2 = volume, in ml, of mercuric acetate solution used for the blank test;
- V = volume, in ml, of sample taken for the test; and
- D = density, in g/ml, of the sample at the temperature at which it was measured.

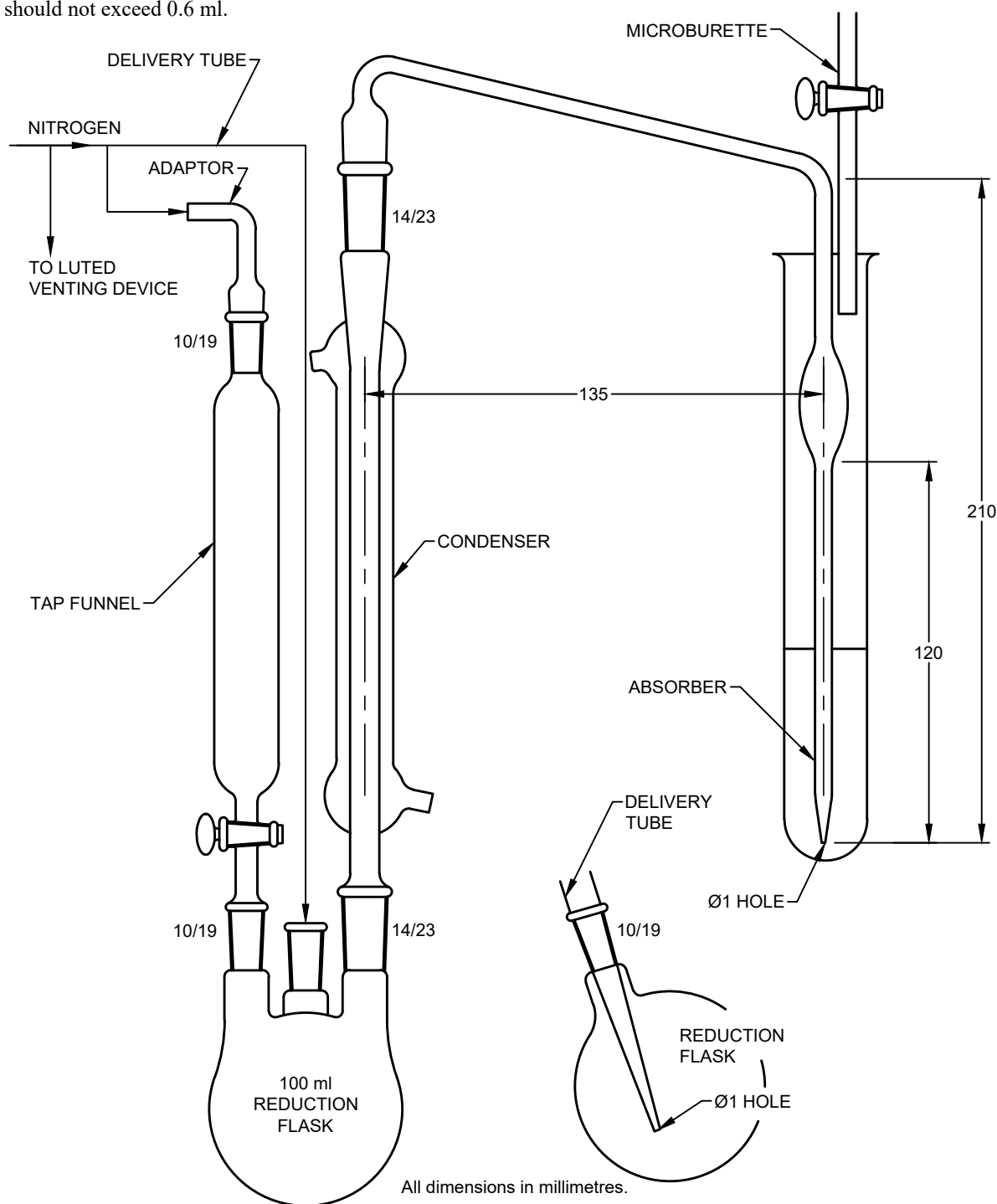

FIG. 3 REDUCTION APPARATUS

ANNEX D

[Table 1, Sl No. (vi)]

DETERMINATION OF DISTILLATION RANGE

D-1 OUTLINE OF THE METHOD

The method includes distillation of 100 ml test portion under prescribed conditions, which are equivalent to simple batch distillation, systematic observation of thermometer readings and volumes of condensate and calculation of the results from these data with correction to standard atmospheric pressure.

D-1.1 SIGNIFICANCE

Distillation indicates volatility of the product. This is an important characteristic not only for the identification of product, but also for its application. It is also used as an internal quality control tool, and in R & D work on hydrocarbons and related materials. It gives a broad indication of general purity of the product.

D-2 DEFINITIONS

For the purpose of this annex, the following definitions shall apply:

D-2.1 Initial Boiling Point

The temperature noted (corrected, if required) at the moment when the first drop of condensate falls from the tip of the condenser during a distillation carried out under standardized conditions.

D-2.2 Dry Point

The temperature noted (corrected, if required) at the moment of vaporization of the last drop of liquid from the bottom of the flask during a distillation carried out under standardized conditions, discarding any liquid on the side of the flask and on the thermometer.

D-2.3 Boiling Range

The temperature interval between the initial boiling point and dry point.

D-3 APPARATUS

The apparatus, a suitable form of which is shown in [Fig. 4](#) to [Fig. 7](#), shall comprise the following items:

D-3.1 Distillation Flask — Made of heat resistant glass, of capacity 200 ml, conforming to the dimensions shown in [Fig. 4](#).

D-3.2 Thermometer

Analog temperature measurement device ([D-3.2.1](#)) or digital temperature measurement device ([D-3.2.2](#)).

D-3.2.1 Analog Temperature Measurement Device

Mercury-in-glass type, nitrogen-filled, graduated on the stem, enamel-backed, and conforming to [Table 4](#).

D-3.2.2 Digital Temperature Measurement Device

Temperature measurement systems using thermocouples or resistance thermometers shall exhibit the same temperature lag, emergent stem effect and accuracy as the equivalent mercury-in glass thermometer. This shall be confirmed at regular intervals potentiometrically by the use of standard precision resistance, depending on the type of probe.

Another technique is to distill pure toluene (99.9 + percent purity) and compare the temperature indicated by the thermocouple or resistance thermometer with that shown by the mercury-in glass thermometer.

D-3.3 Draught Screen**D-3.3.1 For Use with a Gas Burner**

D-3.3.1.1 The draught screen shall be rectangular in cross-section and open at the top and bottom. It shall have the dimensions shown in [Fig. 5](#) and be made of sheet of metal of thickness approximately 1.8 mm.

D-3.3.1.2 In each of the two narrower sides of the draught screen, there shall be two circular holes of diameter 12.5 mm, the centers of which are situated 25 mm above the base of the draught screen. These holes shall occupy the positions shown in [Fig. 5](#).

D-3.3.1.3 At the middle of each of the wider sides, a vertical slot for the condenser tube, dimensioned approximately as shown in [Fig. 5](#), shall be cut downwards from the top of the screen. A removable shutter of suitable dimensions shall be provided for closing whichever vertical slot is not in use. This arrangement enables the condenser (*see* [D-3.6](#)) to be placed on either side of the draught screen.

D-3.3.1.4 A shelf of ceramic material, of thickness 3 mm to 6 mm and possessing a centrally cut circular hole of diameter 75 mm to 100 mm, shall be supported horizontally in the screen and shall fit closely to the sides of the screen, to ensure that hot gases from the source of heat (see [D-3.5](#)) do not come in contact with the sides or neck of the flask (see [D-3.1](#)). The supports for this shelf may conveniently consist of triangular pieces of metal sheet firmly fixed to the screen at its four corners.

D-3.3.1.5 A board as described in [D-3.4](#) shall rest on this shelf.

D-3.3.1.6 In one of the narrower sides of the screen, a door shall be provided having the approximate dimensions shown in [Fig. 5](#) and overlapping the opening in the screen by approximately 5 mm all round.

D-3.3.2 *For Use with an Electric Heater*

When an electric heater is employed, the portion of the draught screen above the shelf shall be as described in [D-3.3.1](#), but the lower portion (including the shelf) may be modified or omitted, provided that the changes does not expose the distillation flask to draughts (see [Fig. 6](#)). Provision shall be made for adjustment of the shelf to facilitate fitting of the flask.

D-3.4 Ceramic Boards

D-3.4.1 It shall be of thickness 3 mm to 6 mm, with central holes of diameter 32 mm or 38 mm respectively and overall dimensions not less than 150 mm². When a gas heater is employed, this board shall rest on the shelf described in [D-3.3.1](#) when an electric heater is employed, the same arrangement shall be adopted, if the shelf is present; alternatively, the board may be placed directly on the heater or it may form the top of the heater. Provision shall be made for adjusting the height of the heater.

D-3.4.2 Whichever type of heater is employed; direct heat shall only be applied to the flask through the central hole in the ceramic board.

D-3.5 Source of Heat

Comprising either a gas burner so constructed that sufficient heat can be obtained to distill the product at the uniform rate specified [D-5.3](#). A sensitive regulating valve or governor is desirable or an electric heater capable of complying with the same requirements (A heater of low heat retention, adjustable from 0 kW to 1 kW, has been found satisfactory).

D-3.6 Condenser

D-3.6.1 A seamless brass tubing, of length 560 mm, outside diameter 14 mm and wall thickness 0.8 mm to 0.9 mm, surrounded by a metal cooling bath, preferably of copper or brass. The tube shall be set so that a length of approximately 390 mm is in contact with the cooling medium in the cooling bath, with about 50 mm outside the cooling bath at the upper end, and about 110 mm outside at the lower end. The length of the tube projecting at the upper end shall be straight and set at an angle of 75 degrees to the vertical. The section of the tube inside the cooling bath may be either straight or bent in any suitable continuous smooth curve. The average gradient shall be 0.26 mm per linear millimetre of the condenser tube ($\sin 15^\circ$), and no part of the immersed portion of the condenser tube shall have a gradient less than 0.24 mm nor more than 0.28 mm per linear millimeter of the tube. The projecting lower portion of the condenser tube shall be curved downward for a length of 76 mm and slightly backward so as to ensure contact with the wall of the receiver (see [D-3.7](#)) at a point 25 mm to 32 mm below the top of the receiver when it is in a position to receive the distillate. The lower end of the condenser tube shall be cut off at an acute angle so that the tip may be brought into contact with the wall of the receiver.

D-3.6.2 The capacity of the cooling bath shall be not less than 5.5 litre of cooling medium. The arrangement of the tube in the cooling bath shall be such that its center line is not less than 32 mm below the plane of the top of the bath at its point of entrance, and not less than 19 mm above the floor of the bath at its exit. Clearances between the condenser tube and the walls of the bath shall be at least 13 mm, except for the section adjacent to the points of entrance and exit.

D-3.6.3 The cooling bath may be provided with a tap at the bottom for drainage or inlet, and with an overflow tube near the top.

D-3.6.4 The main dimensions of the tube and cooling bath are shown in [Fig. 5](#).

D-3.7 Receiver

It shall be of capacity 100 ml, complying with the details shown in [Fig. 7](#). None of the graduation lines shall be in error by more than 1 ml. The shape of the base is optional but it shall be such that the receiver does not topple when placed empty on a surface inclined at an angle of 15 to the horizontal.

D-3.8 Barometer — Capable of measuring to the nearest 1 mbar, 0.1 kPa or 1 mm Hg.

D-4 ASSEMBLY AND PREPARATION OF APPARATUS

D-4.1 Assembly

Assemble the apparatus, swabbing out the condenser with a piece of lint-free cloth attached to a wire cord or by any other suitable means, and paying attention to the following details:

D-4.1.1 Position and Choice of Thermometer

Use any thermometer as indicated at [D-3.2](#). Centre the thermometer/probe into the neck of the flask through a tight-fitting silicone-rubber or cork stopper so that the upper end of the contraction chamber is level with the lower wide of the vapour tube at its junction with the neck of the flask.

D-4.1.2 Support for Flask

If a draught screen with ceramic shelf is used, place the appropriate ceramic board (see [D-3.4](#) and [D-5.3](#)) on top of the shelf so that the two holes are concentric.

D-4.1.3 Connection of Flask to Condenser

D-4.1.3.1 Make a leak-proof connection of the flask (see [D-3.1](#)) to the tube of the condenser (see [D-3.6](#)) by means of a tight-fitting silicone-rubber or cork stopper through which the vapour tube of the flask passes. Connect the flask to the condenser so that the flask is in a vertical position; the end of the vapour tube shall extend at least 25 mm and not more than 50 mm beyond the cork into the condenser tube and shall be co-axial with it.

D-4.1.3.2 Place the flask in such a position on the board that the base completely closes the hole in the board.

D-4.2 Filling of Cooling Bath

Fill the bath with water or with water and crack ice in sufficient quantity to cover the condenser tube, so as to ensure that the temperature of the bath at the start of and during distillation remains between 25 °C to 30 °C.

D-4.3 Adjustment of Temperature of Sample

Adjust the temperature of the sample to between 20 °C to 30 °C, to prevent excessive evaporation of the product.

D-5 PROCEDURE

D-5.1 Test Portion

Using the graduated receiver (see [D-3.7](#)), measure

(100 ± 0.5) ml of the sample at the temperature to which it has been adjusted as specified in [D-4.3](#). Remove the flask (see [D-3.1](#)) from the apparatus and transfer the test portion directly to the flask, allowing the receiver to drain for 15s to 20s. Do not allow any of the test portion to enter the vapour tube.

D-5.2 Apparatus Assembly

D-5.2.1 Connect the flask to the condenser (see [D-3.6](#)) and insert the thermometer/probe (see [D-3.2](#)) as described in [D-4.1.1](#) and position the flask as described in [D-4.1.3](#). Place the receiver (see [D-3.7](#)), without drying, at the outlet of the condenser tube in such a position that the condenser tube extends into the receiver at least 25 mm but does not extend below the 100 ml mark.

D-5.2.2 Place a flat cover on the top of the receiver to prevent entry of condensed moisture.

D-5.3 Operating Conditions

A certain amount of judgement is necessary in choosing the best operating conditions to obtain acceptable accuracy and reproducibility. As a general guide it is recommended that the following conditions shall be established:

- (a) Flask support — Hole diameter, 32 mm; and
- (b) Heating rate — Time from application of heat to collection of first drop of distillate 5 min to 10 min, and time for rise of vapour column in neck to flask to side arm, 2.5 min to 3.5 min.

D-5.4 Initial Boiling Point

Record the temperature at the instant the first drop of distillate falls from the tip of the condenser as the initial boiling point (see [D-2.1](#)).

D-5.5 Distillation

Adjust the heat input so that the distillation proceeds at a rate of 4 ml/min to 5 ml/min (approximately 2 drops per second), and move the receiver so that the tip of the condenser tube touches one side of the cylinder after the first drop falls.

D-5.6 Dry Point

Without changing the heater setting, continue distillation beyond the 95 percent point until the dry point (see [D-2.2](#)) is observed. Record the temperature at this moment as the dry point. If a dry point is not obtained (that is, if active decomposition occurs before the dry point is reached, as shown by a rapid evolution of vapour

or heavy fumes, or if there is liquid remaining on the bottom of the flask when the maximum temperature is observed in the distillation thermometer), record this fact.

D-5.7 Atmospheric Pressure

Read and record the barometric pressure to the nearest 1 mbar, 0.1 kPa or 1 mm Hg.

D-6 CALCULATIONS

D-6.1 Thermometer Bore Correction

Apply the correction for any variation in the bore of the thermometer as given by the calibration certificate.

D-6.2 Thermometer Bulb Shrinkage Correction

Apply the correction for shrinkage of the mercury bulb of the thermometer as determined by any change in its ice or steam point, where applicable. Other means can be employed, such as the use of a platinum-resistance thermometer or a recognized standard thermometer.

D-6.3 Barometer Correction

After applying the corrections for thermometer error, correct each reading for deviation of the barometric pressure from normal by adding algebraically the correction, calculated as follows:

$$K \times (760 - p_0) \text{ or} \\ K' \times (1013 - p_1) \text{ or} \\ K' \times (1013 - p_2)$$

where

- K = rate of change of boiling point, in °C/mm Hg with pressure (see [Table 5](#));
- K' = rate of change of boiling point, in °C/mbar or °C/0.1 kPa with pressure (see [Table 5](#));
- p_0 = barometric pressure, in mm Hg during the test;
- p_1 = barometric pressure, in millibars during the test; and
- p_2 = the barometric pressure, in kilopascals, during the test.

Table 4 Requirements of Thermometer
(Clauses [D-3.2.1](#))

Sl No.	Characteristic	Requirement
(1)	(2)	(3)
(i)	Immersion, mm	100
(ii)	Range, °C	72 to 126
(iii)	Graduation, °C	0.2
(iv)	Longer lines at each. °C	1
(v)	Figured at each, °C	2
(vi)	Scale error not to exceed, °C	0.2
(vii)	Overall length, mm	395 ± 5
(viii)	Stem diameter, mm	6 to 7
(ix)	Bulb length, mm	15 to 20
(x)	Distance from bottom of bulb, mm	
	to 72 °C	125 to 145
	to 127 °C	335 to 360
(xi)	Expansion chamber to allow heating to, °C	150

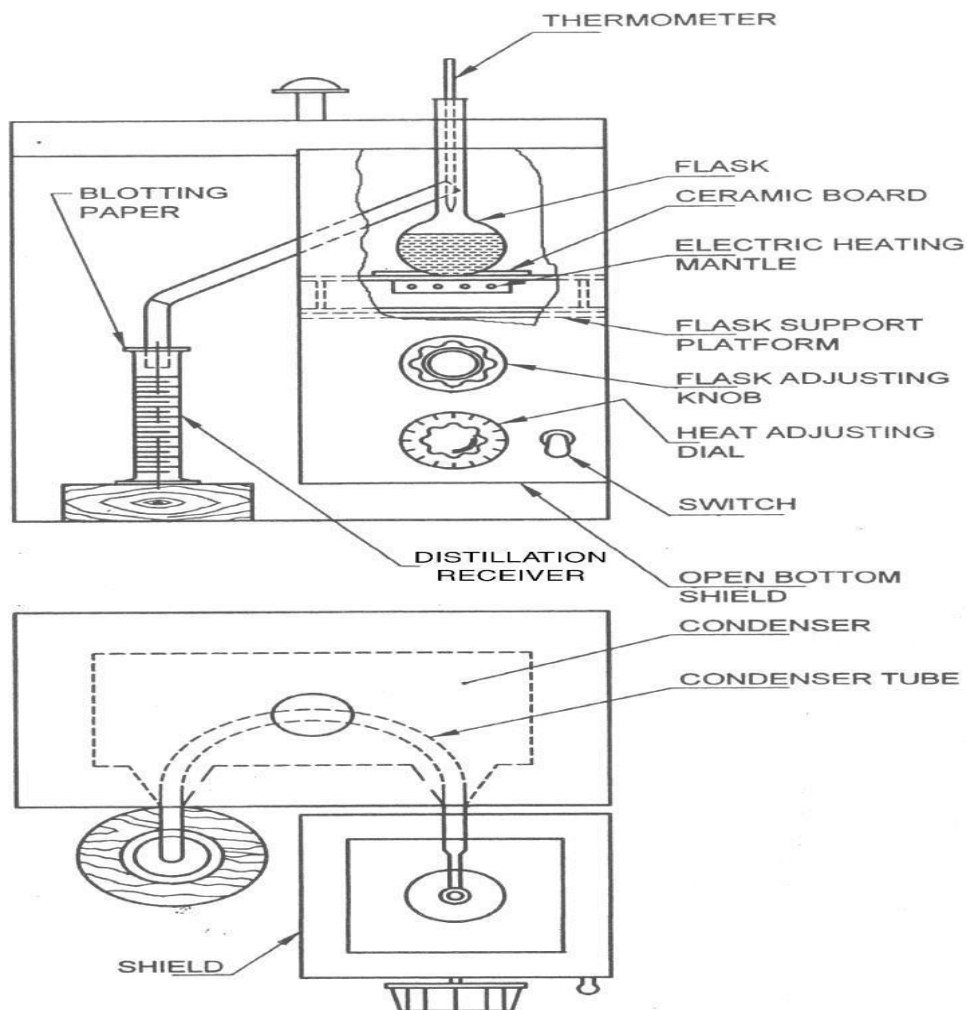
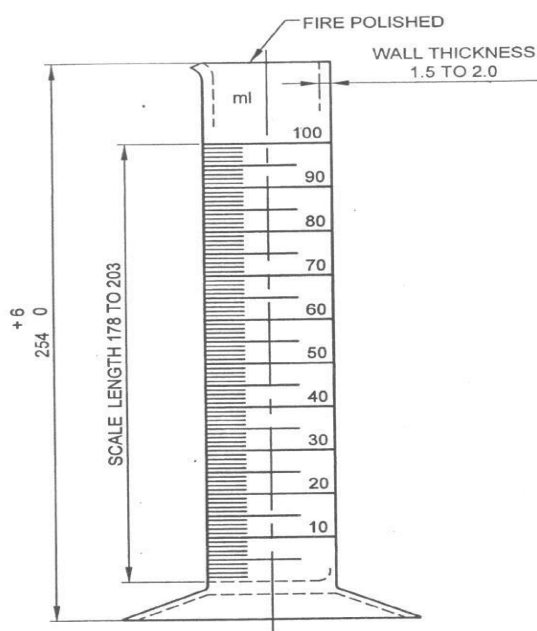

FIG. 6 DISTILLATION APPARATUS USING ELECTRIC HEATER



All dimensions in millimetres.
FIG. 7 DISTILLATION RECEIVER

Table 5 Boiling Point*(Clause D-6.3)*

SI No.	Characteristic	Requirement
(1)	(2)	(3)
(i)	Boiling point °C (at 1.013 bar, 101.3 kPa, 760 mm Hg)	110.6
(ii)	Rate of change of boiling point with pressure K' (°C/mbar),	0.035
(iii)	Rate of change of boiling point with pressure K (°C/mm Hg)	0.046

ANNEX E*(Clause 6)***SAMPLING OF TOLUENE****E-1 GENERAL REQUIREMENTS OF SAMPLING**

E-1.1 In drawing, preparing, storing and handling test samples, the following precautions and directions shall be observed:

- a) Samples shall not be taken in an exposed place;
- b) Sampling instrument shall be clean and dry and shall be made of low or reduced spark generating material;
- c) Samples, the material being sampled, the sampling instrument and the containers for samples shall be protected from adventitious contamination;
- d) To draw a representative sample, the contents of each container selected for sampling shall be mixed as thoroughly as possible by shaking or stirring or both, or by rolling, so as to bring all portions into uniform distribution;
- e) Samples shall be placed in suitable, clean, dry and air-tight glass containers preferably of amber or blue colour;
- f) Sample container shall be sealed air-tight with a suitable stopper after filling and marked with full details of sampling, such as the date of sampling, the year of manufacture of material, the batch number, the name of the sample, etc. Particular care shall be taken to ensure that sealing methods do not contaminate the sample; and
- g) Samples shall be stored in such a manner that the temperature of the material does not vary unduly from the normal temperature.

E-1.2 Additional Precautions

The following additional precautions shall be observed:

- a) Rubber stoppers or composition corks shall not be used for closing the sample bottles;
- b) Sealing wax or other plastic material, if used, shall be applied in such a way that it does not contaminate the sample when the bottles are opened; and
- c) Each sample container shall be protected by covers of oil-proof paper, metal foil, viscose or other suitable impervious material over the stopper to keep away moisture and dusts from the mouth of the bottle and to protect it while being handled.

E-2 SAMPLING INSTRUMENT

The following forms of sampling instrument may be used:

- a) Sampling bottle or can for taking samples from various depths in large tanks; and
- b) Sampling tube.

E-2.1 Sampling Bottle or Can

It consists of a weighed bottle or metal container with removable stopper or top, to which is attached a light chain (*see Fig. 8*). The bottle or can is fastened to a suitable pole. For taking a sample, it is lowered in the tank to the required depth, and the stopper or top is removed by means of the chain for filling the container.

E-2.2 Sampling Tube

E-2.2.1 It is made of metal or thick glass and is about 20 mm to 40 mm in diameter and 400 mm to 800 mm in length (see Fig. 9). The upper and lower ends are conical and reach 5 mm to 10 mm internal diameter at the narrow ends. Handling is facilitated by two rings at the upper end. For taking a sample, the apparatus is first closed at the top with the thumb or a stopper and lowered until the desired depth is reached. It is then opened for a short time to admit the material and finally closed and withdrawn.

E-2.2.2 For small containers, the size of the sampling tube may be altered suitably.

E-3 SCALE OF SAMPLING

E-3.1 Lot

E-3.1.1 In a single consignment, all the containers of the same size and drawn from the same batch of manufacture shall constitute a lot. If a consignment is known to consist of containers of different sizes or of different batches of manufacture, then the containers belonging to the same size and batch of manufacture shall be grouped together and each such group shall constitute a separate lot. In case the consignment is in large tanks or vessels, the tanks or vessels belonging to the same batch of manufacture shall constitute a lot.

E-3.1.2 For ascertaining the conformity of the lot to the requirement of the specification, tests shall be carried out for each lot separately.

E-3.2 Sampling from Containers

The number of containers to be selected for sampling shall depend on the size of the lot and shall be in accordance with Table 6.

E-3.3 The containers shall be selected at random in order to ensure the randomness of selection, procedure given in IS 4905 may be adopted.

E-3.4 Sampling from Tanks or Vessels

Each of the tanks or vessels in the lot shall be sampled separately for determining the conformity of the lot to the requirements of the standard.

E-4 PREPARATION OF THE TEST SAMPLES

E-4.1 Test Samples from Containers

To ensure that the sample taken from each container is fairly representative, the containers shall be mixed thoroughly, when possible, by shaking or

stirring or rolling. Draw small samples of the material from various depths with the help of the sampling tube (see Fig. 9). The approximate quantity of the material to be drawn from a container shall be nearly equal to thrice the quantity required for testing purposes as indicated in E-5.1.

E-4.1.1 Out of the material drawn from individual containers, a small but equal quantity of material shall be taken and thoroughly mixed to form a composite sample, sufficient for carrying out triplicate determinations for all the characteristics specified under E-5. The composite sample shall be divided into three equal parts, one for the purchaser, another for the supplier and the third for the referee.

E-4.1.2 The remaining portion of the material from each container shall be divided into 3 equal parts, each forming an individual sample. One set of individual samples representing the containers selected shall be for the purchaser, another for the supplier and the third for the referee.

E-4.1.3 All the individual and composite samples shall be transferred to separate sample containers. These containers shall then be sealed airtight with stoppers and labeled with full identification particulars given in E-1.1 (f).

E-4.1.4 The referee test sample, consisting of a composite sample and a set of individual samples, shall bear the seals of both the purchaser and the supplier. They shall be kept at a place agreed to between the purchaser and the supplier, to be used in case of any dispute.

E-4.2 Test Samples from Tanks or Vessels

E-4.2.1 For drawing a sample from a tank or vessel, lower the closed sampling bottle or can (see E-2.1) slowly to the required depth, open and fill it at that depth. Three samples shall be obtained at levels of one-tenth of the depth of the liquid from the top surface (top sample), one half of the depth (middle sample) and nine-tenths of the depth of the liquid from the top surface (lower sample). All the three samples thus obtained from a tank/vessel shall be mixed together in a clean dry container, and shall be divided into three parts, one for the purchaser, another for the supplier and the third for the referee. Each of the tanks or vessels in the lot shall be sampled in the above manner and separate samples obtained for each of the tanks or vessels. The approximate quantity of the material to be drawn from a tank or a vessel shall nearly be equal to thrice the quantity required for carrying out tests for all the requirements prescribed in E-5.

E-4.2.2 All the samples thus obtained from the tanks or vessels in the lot shall be transferred to

separate sample containers. These containers shall then be sealed air-tight with stoppers and labelled with full identification particulars given in [E-1.1 \(f\)](#).

E-4.2.3 The referee test samples consisting of the samples from the tanks or vessels in the lot, shall bear the seals of both the purchaser and the supplier. They shall be kept at a place agreed to between the purchaser and the supplier, to be used in case of any dispute.

E-5 NUMBER OF TESTS

E-5.1 For Samples from Containers

E-5.1.1 Test for the determination of distillation range, if conducted, shall be conducted on each of the individual samples separately (see [E-4.1.2](#)).

NOTE — Distillation test is optional.

E-5.1.2 Tests for the determination of all other characteristics given in [Table 1](#) shall be conducted on the composite samples separately (see [E-4.1.1](#)).

E-5.2 For Samples from Tanks or Vessels

Tests for the determination of all the characteristics given in [Table 1](#) shall be conducted on the samples from different tanks or vessels, separately.

E-6 CRITERIA FOR CONFORMITY

E-6.1 For Containers

E-6.1.1 For Individual Samples

The lot shall be declared as conforming to the requirements of the distillation range if test results for each of the individual samples tested in respect of distillation range satisfy the requirements as given in [Table 1](#).

NOTE — Distillation test is optional.

E-6.1.2 For Composite Samples

In respect of all other characteristics, the lot shall be considered as conforming to the standard if the composite sample satisfies all the requirements, except distillation range, prescribed in [Table 1](#).

E-6.2 For Tanks or Vessels

The lot shall be declared as conforming to the standard if samples from each different tank or vessel satisfy the requirements prescribed in [Table 1](#).

NOTE — Distillation test is optional.

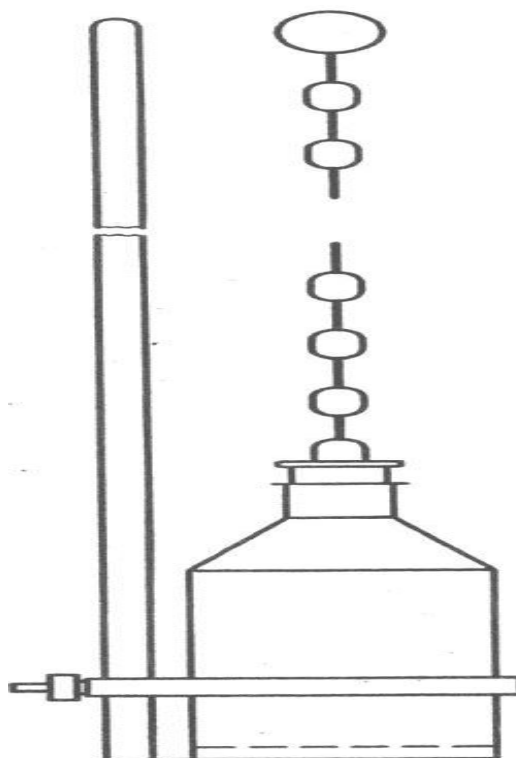
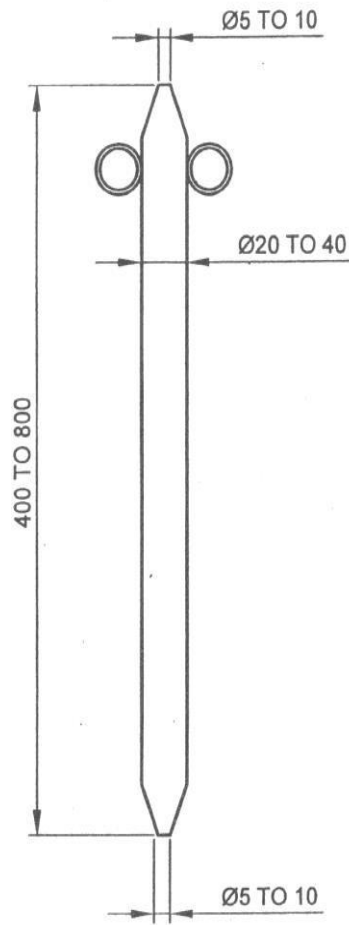

FIG. 8 SAMPLING BOTTLE OR CAN



All dimensions in millimetres

FIG. 9 SAMPLING TUBE

Table 6 Scale of Sampling

([Clause E-3.2](#))

Sl No.	Lot Size	No. of Containers to be Selected
(1)	(2)	(3)
(i)	Up to 100	5
(ii)	101 to 200	6
(iii)	201 to 300	7
(iv)	301 to 400	8
(v)	401 to 500	9
(vi)	501 and above	10

NOTE — In the case of very small lots where the selection of the five containers may be uneconomical, all the containers shall be selected

ANNEX F

(Foreword)

COMMITTEE COMPOSITION

Petroleum and Their Related Products of Synthetic or Biological or Natural Origin Sectional Committee, PCD 03

<i>Organization</i>	<i>Representative(s)</i>
CSIR - Indian Institute of Petroleum, Dehradun	DR HARENDER SINGH BISHT (Chairperson)
Ashok Leyland Limited, Chennai	SHRI MAHESH P. SHRI BALAKRISHNAN D. (<i>Alternate</i>)
Association of State Road Transport Undertakings, New Delhi	SHRI V. V. RATNAPARKHI SHRI R. R. K. KISHORE (<i>Alternate</i>)
Automotive Research Association of India, Pune	SHRI M. A. BAWASE SHRI M. I. JAMADAR (<i>Alternate</i>)
Bajaj Auto Limited, Pune	SHRI YOGESH. R. MAHAJAN SHRI RAMESH GOYKAR (<i>Alternate</i>)
Bharat Petroleum Corporation Limited, Mumbai	SHRI R. SUBRAMANIAN SHRI C. SHANMUGANATHAN (<i>Alternate</i>)
Bio Diesel Association of India, Mumbai	SHRI N. S. BALAMUKUNDAN SHRI SANJEEV GUPTA (<i>Alternate</i>)
Bosch Limited, Bengaluru	SHRI FREDRICK A.
Centre for High Technology, New Delhi	SHRI P. RAMAN DR N. S. RAMAN (<i>Alternate</i>)
Centre for Science and Environment, New Delhi	SHRIMATI ANUMITA ROY CHOWDHURY SHRI VIVEK (<i>Alternate</i>)
Chennai Petroleum Corporation Limited, Chennai	SHRI H. RAMAKRISHNAN SHRI ABDUL KAREEM (<i>Alternate</i>)
Consumer Guidance Society of India, Mumbai	DR SITARAM DIXIT DR M. S. KAMATH (<i>Alternate</i>)
CSIR - Indian Institute of Petroleum, Dehradun	DR ANIL KUMAR SINHA DR THALLADA BHASKER (<i>Alternate</i>)
Directorate General of Aeronautical Quality Assurance, New Delhi	SHRI SANTOSH NAMDEO
Directorate General of Civil Aviation, New Delhi	SHRI RAKESH KUMAR SHRI AMIT GUPTA (<i>Alternate I</i>) SHRI DHARMENDRA SINGH YADAV (<i>Alternate II</i>)
Directorate General of Quality Assurance, Ministry of Defence, Kanpur	DR OM PRAKASH SINGH SHRI A. K. KANAUIA (<i>Alternate</i>)
DRDO - Centre for Military Airworthiness and Certification, Bengaluru	SHRI R. SHANMUGAVEL SHRI R. KAMALAKANNAN (<i>Alternate</i>)
Gulf Oil Lubricants India Limited, Mumbai	SHRI JENCEN MATHAI

<i>Organization</i>	<i>Representative(s)</i>
Hero Motocorp Limited, New Delhi	SHRI FEROZ ALI KHAN SHRI RAKESH SHARMA (<i>Alternate</i>)
Hindustan Petroleum Corporation Limited, Mumbai	SHRI ELECHERAN KUMAR SHRI SANTOSH DHAKU BHOGALE (<i>Alternate I</i>) SHRI SHITANSHU PATI TRIPATHI (<i>Alternate II</i>)
Indian Biogas Association, Gurugram	DR A. R. SHUKLA
Indian Oil Corporation Limited, New Delhi	SHRI MANISH MALHAN SHRI A. S. KRISHNAMOORTHY (<i>Alternate</i>)
Indian Oil Corporation (R & D Centre), Faridabad R & D	DR AJAY KUMAR ARORA
Indian Oil Corporation Limited - Refineries and Pipelines Division, New Delhi	SHRI R. K. KAUSHIK DR Y. S. JHALA (<i>Alternate</i>)
Lubrizol India Limited, Mumbai	SHRI ANAND REDKAR
Mahindra and Mahindra Limited, Mumbai	SHRI R. RAMAPRABHU
Mangalore Refinery and Petro Chemical Limited, Mangaluru	SHRI V. NANDA KUMAR SHRI SUDHEER PAI. M. (<i>Alternate</i>)
Maruti Udyog Limited, Gurugram	SHRI AJAY KUMAR SHRI NISHANT SARNA (<i>Alternate I</i>) SHRIMATI ABHA RANI (<i>Alternate II</i>)
Ministry of Petroleum and Natural Gas, New Delhi	SHRI MANISH SARDA SHRI RAJESH MANOCHA (<i>Alternate</i>)
Nayara Energy Limited, Mumbai	SHRI SABYASACHI KUMAR SHRI PRATIK SHAH (<i>Alternate</i>)
Oil and Natural Gas Corporation Limited, New Delhi	SHRI GOUR MOHAN DASS SHRIMATI LEENA JOHN (<i>Alternate I</i>) SHRI DINESH S. R. REDDY KAKUTURI (<i>Alternate II</i>)
Reliance India Limited, Mumbai	SHRI BALASUBRAMANIAN K. SHRI PRAMOD MALL (<i>Alternate</i>)
Society of Indian Automobile Manufacturers (SIAM), New Delhi	SHRI PRASHANT KUMAR BANERJEE DR SANDEEP GARG (<i>Alternate I</i>) SHRI DIWIT PRAJAPATI (<i>Alternate II</i>)
Tata Motors Limited, Pune	SHRI SETHURAMALINGAM TYAGARAJAN SHRI GOWRISHANKAR P. S. (<i>Alternate</i>)
TVS Motor Company Limited, Hosur	DR JABEZ DHINAGAR SHRI M. S. ANANDKUMAR (<i>Alternate</i>)

<i>Organization</i>	<i>Representative(s)</i>
In Personal Capacity (<i>Flat - 1002, Raheja Heights, D-Wing, off Gen A. K.Vaidya Marg, Dindoshi</i>)	DR Y. P. RAO
BIS Directorate General	SHRIMATI MEENAL PASSI, SCIENTIST 'F'/SENIOR DIRECTOR AND HEAD (PETROLEUM, COAL AND RELATED PRODUCTS) [REPRESENTING DIRECTOR GENERAL (<i>Ex-officio</i>)]

Member Secretary
SHRIMATI KRETI DAS
SCIENTIST 'C'/DEPUTY DIRECTOR
(PETROLEUM, COAL AND RELATED PRODUCTS), BIS

PCD 03: 02 Aromatic Hydrocarbons, Petroleum Solvents and Preservatives Sub Committee

<i>Organization</i>	<i>Representative(s)</i>
Mangalore Refinery and Petro Chemical Limited, Mangaluru	SHRI V. NANDA KUMAR
Bharat Petroleum Corporation Limited, Mumbai	SHRI C. SHANMUGANATHAN SHRI SIDDHARTHA MITRA (<i>Alternate</i>)
Central Pollution Control Board, New Delhi	SHRI DINABANDHU GOUDA
Centre for High Technology, New Delhi	DR N. S. RAMAN SHRI P. RAMAN (<i>Alternate I</i>) SHRI SHEKAR KULKARNI (<i>Alternate II</i>)
Chennai Petroleum Corporation Limited, Chennai	SHRI H. RAMAKRISHNAN SHRI ABDUL KAREEM (<i>Alternate</i>)
CSIR - Indian Institute of Petroleum, Dehradun	DR SANAT KUMAR SHRI PRASENJIT GHOSH (<i>Alternate</i>)
Federation of Indian Petroleum Industry, New Delhi	SHRI D. L. N. SASTRI
Goa Carbon Limited, Panaji	SHRI ANUPAM MISRA SHRI VENUGOPALA NAIDU (<i>Alternate</i>)
Hindalco Industries Limited, Mumbai	SHRI KRISHNAN VENKATESH SHRI HARSHAD KUMAR (<i>Alternate</i>)
Hindustan Petroleum Corporation Limited (HP Green R & D Center), Bengaluru	SHRI B. RAVI SHRI K. RAGHAVA (<i>Alternate</i>)
Hindustan Petroleum Corporation Limited, Mumbai	SHRI ELECHERAN KUMAR SHRI S. N. SHESHACHALA (<i>Alternate I</i>) SHRI SHITANSHU PATI (<i>Alternate II</i>)
Indian Oil Corporation (R and D Centre), Faridabad	DR M. SAU DR AJAY KUMAR ARORA (<i>Alternate</i>)
Indian Oil Corporation Limited, Mumbai	SHRI MANISH MALHAN SHRI A. S. KRISHNAMOORTHY (<i>Alternate</i>)
Indian Paints Association, Kolkata	DR M. B. GUHA
Mangalore Refinery and Petro Chemical Limited, Mangaluru	SHRI SUDHEER PAI. M. SHRI HARADI ANAND ASHOK (<i>Alternate</i>)
National Aluminium Company Limited, Bhubaneswar	SHRI SACHIDANANDA JENA SHRI TARUNA KUMAR (<i>Alternate</i>)
Nayara Energy Limited, Mumbai	SHRI PRATIK SHAH SHRI MILAN VASOYA (<i>Alternate</i>)
Indian Oil Corporation Limited - Refineries and Pipelines Division, New Delhi	SHRI MOUSOM SOME SHRI S. BHAR (<i>Alternate</i>)

<i>Organization</i>	<i>Representative(s)</i>
Oil and Natural Gas Corporation Limited, New Delhi	SHRI GOUR MOHAN DASS SHRI MATI LEENA JOHN (<i>Alternate I</i>) SHRI DINESH S. R. REDDY (<i>Alternate II</i>)
Reliance Industries Limited, Mumbai	SHRI. VASANT WARKE SHRI PRAMOD MALL (<i>Alternate</i>)
The Solvent Extractors Association of India, Mumbai	SHRI A. R. SHARMA DR V. S. VADKE (<i>Alternate</i>)

Bureau of Indian Standards

BIS is a statutory institution established under the *Bureau of Indian Standards Act, 2016* to promote harmonious development of the activities of standardization, marking and quality certification of goods and attending to connected matters in the country.

Copyright

BIS has the copyright of all its publications. No part of these publications may be reproduced in any form without the prior permission in writing of BIS. This does not preclude the free use, in the course of implementing the standard, of necessary details, such as symbols and sizes, type or grade designations. Enquiries relating to copyright be addressed to the Head (Publication & Sales), BIS.

Review of Indian Standards

Amendments are issued to standards as the need arises on the basis of comments. Standards are also reviewed periodically; a standard along with amendments is reaffirmed when such review indicates that no changes are needed; if the review indicates that changes are needed, it is taken up for revision. Users of Indian Standards should ascertain that they are in possession of the latest amendments or edition by referring to the website-www.bis.gov.in or www.standardsbis.in.

This Indian Standard has been developed from Doc No.: PCD 03 (19709).

Amendments Issued Since Publication

Amend No.	Date of Issue	Text Affected

BUREAU OF INDIAN STANDARDS

Headquarters:

Manak Bhavan, 9 Bahadur Shah Zafar Marg, New Delhi 110002

Telephones: 2323 0131, 2323 3375, 2323 9402

Website: www.bis.gov.in

Regional Offices:

	Telephones
Central : 601/A, Konnectus Tower -1, 6 th Floor, DMRC Building, Bhavbhuti Marg, New Delhi 110002	{ 2323 7617
Eastern : 8 th Floor, Plot No 7/7 & 7/8, CP Block, Sector V, Salt Lake, Kolkata, West Bengal 700091	{ 2367 0012 2320 9474
Northern : Plot No. 4-A, Sector 27-B, Madhya Marg, Chandigarh 160019	{ 265 9930
Southern : C.I.T. Campus, IV Cross Road, Taramani, Chennai 600113	{ 2254 1442 2254 1216
Western : 5 th Floor/MTNL CETTM, Technology Street, Hiranandani Gardens, Powai Mumbai 400076	{ 25700030 25702715

Branches : AHMEDABAD, BENGALURU, BHOPAL, BHUBANESHWAR, CHANDIGARH, CHENNAI, COIMBATORE, DEHRADUN, DELHI, FARIDABAD, GHAZIABAD, GUWAHATI, HARYANA (CHANDIGARH), HUBLI, HYDERABAD, JAIPUR, JAMMU, JAMSHEDPUR, KOCHI, KOLKATA, LUCKNOW, MADURAI, MUMBAI, NAGPUR, NOIDA, PARWANOO, PATNA, PUNE, RAIPUR, RAJKOT, SURAT, VIJAYAWADA.