

प्लास्टिक — परीक्षण पद्धतियाँ

भाग 5 यांत्रिक गुण

अनुभाग 30 उच्च विकृति दर पर तन्य  
गुणों का निर्धारण

Plastics — Methods of Testing

Part 5 Mechanical Properties

Section 30 Determination of Tensile  
Properties at High Strain Rates

ICS 83.080.10

© BIS 2024

© ISO 2007



भारतीय मानक ब्यूरो

BUREAU OF INDIAN STANDARDS

मानक भवन, 9 बहादुर शाह ज़फर मार्ग, नई दिल्ली - 110002

MANAK BHAVAN, 9 BAHADUR SHAH ZAFAR MARG  
NEW DELHI - 110002

[www.bis.gov.in](http://www.bis.gov.in) [www.standardsbis.in](http://www.standardsbis.in)

## NATIONAL FOREWORD

This Indian Standard which is identical to ISO 18872 : 2007 'Plastics — Determination of tensile properties at high strain rates' issued by the International Organization for Standardization (ISO) was adopted by the Bureau of Indian Standards on the recommendations of the Methods of Sampling and Test for Plastics Sectional Committee and approval of the Petroleum, Coals and Related Products Division Council.

The text of ISO standard has been approved as suitable for publication as an Indian Standard without deviations. Certain conventions are, however, not identical to those used in Indian Standards. Attention is particularly drawn to the following:

- a) Wherever the words 'International Standard' appear referring to this standard, they should be read as 'Indian Standard'; and
- b) Comma (,) has been used as a decimal marker while in Indian Standards, the current practice is to use a point (.) as the decimal marker.

In this adopted standard, reference appears to certain International Standard for which Indian Standard also exist. The corresponding Indian Standard, which are to be substituted in their respective places, are listed below along with their degree of equivalence for the editions indicated:

<i>International Standard</i>	<i>Corresponding Indian Standard</i>	<i>Degree of Equivalence</i>
ISO 527-1 : 1993 Plastics — Determination of tensile properties — Part 1: General principles	IS 13360 (Part 5/Sec 1) : 2021/ ISO 527-1 : 2019 Plastics — Methods of testing: Part 5 Mechanical properties, Section 1 Determination of tensile properties — General requirements ( <i>second revision</i> )	Identical
ISO 527-2 Plastics — Determination of tensile properties — Part 2: Test conditions for moulding and extrusion plastics	IS 13360 (Part 5/Sec 2) : 2017/ ISO 527-2 : 2012 Plastics — Methods of testing: Part 5 Mechanical properties, Section 2 Determination of tensile properties — Test conditions for moulding and extrusion plastics ( <i>first revision</i> )	Identical
ISO 2818 Plastics — Preparation of test specimens by machining	IS 13360 (Part 2/Sec 4) : 2021/ ISO 2818 : 2018 Plastics — Methods of testing: Part 2 Sampling and preparation of test specimens, Section 4 Preparation of test specimens by machining ( <i>second revision</i> )	Identical

In reporting the result of a test or analysis made in accordance with this standard, if the final value, observed or calculated, is to be rounded off, it shall be done in accordance with IS 2 : 2022 'Rules for rounding off numerical values (*second revision*)'.

**Contents**

Page

- 1 Scope ..... 1
- 2 Normative references ..... 1
- 3 Principle ..... 1
- 4 Terms and definitions..... 1
- 5 Apparatus ..... 2
  - 5.1 Test assembly ..... 2
  - 5.2 Extensometers ..... 2
  - 5.3 Data-recording equipment ..... 2
- 6 Test specimens ..... 2
  - 6.1 Low-strain measurements ..... 2
  - 6.2 High-strain measurements ..... 2
- 7 Conditioning..... 3
- 8 Test procedure ..... 3
  - 8.1 General..... 3
  - 8.2 Test speeds ..... 3
  - 8.3 Recording of data ..... 3
- 9 Calculation and expression of results..... 3
  - 9.1 Low-strain measurements ..... 3
  - 9.2 High-strain measurements ..... 4
- 10 Modelling stress versus plastic strain curves..... 6
  - 10.1 Low-strain measurements ..... 6
  - 10.2 High-strain measurements ..... 6
- 11 Determination of properties over a wide range of strain rates ..... 6
  - 11.1 Tensile modulus..... 6
  - 11.2 Stress/plastic strain curves ..... 6
- 12 Precision ..... 7
- Annex A (informative) Modelling true stress against true plastic strain curves: Low-strain measurements..... 8**
- Annex B (informative) Modelling true stress against true plastic strain curves: High-strain measurements ..... 11**



*Indian Standard*

## PLASTICS — METHODS OF TESTING

### PART 5 MECHANICAL PROPERTIES

#### SECTION 30 DETERMINATION OF TENSILE PROPERTIES AT HIGH STRAIN RATES

#### 1 Scope

This International Standard specifies procedures for determining the tensile properties of moulding and extrusion plastics over a wide range of strain rates, including high rates appropriate to impact-loading situations. Properties are determined through a combination of measurements at low and moderate strain rates, the use of mathematical functions to model these results, the rate-dependence of parameters and the determination of parameters at high strain rates by extrapolation. Tensile properties at high strain rates are then derived by calculation. In this way, the experimental problems and associated errors with the measurement of properties at high rates are avoided.

The measurement of properties at low and moderate strain rates is based on ISO 527-2, which identifies the types of plastics materials to which this International Standard is applicable.

#### 2 Normative references

The following referenced documents are indispensable for the application of this document. For dated references, only the edition cited applies. For undated references, the latest edition of the referenced document (including any amendments) applies.

ISO 527-1:1993, *Plastics — Determination of tensile properties — Part 1: General principles*

ISO 527-2, *Plastics — Determination of tensile properties — Part 2: Test conditions for moulding and extrusion plastics*

ISO 2818, *Plastics — Preparation of test specimens by machining*

#### 3 Principle

Tensile stress versus strain curves are measured in accordance with ISO 527-2 at selected speeds in the range 0,1 mm/s to 100 mm/s. In order to maximize the accuracy of these results at the higher speeds, it is necessary to pay attention to certain features of the design of the test assembly as described in Clause 5. Measurements are also made of the variation of Poisson's ratio with strain. From these results, values of true stress and true plastic strain are calculated at each strain rate. A mathematical function is used to accurately model the shape of each stress/plastic strain curve. The variation of parameters in this function with strain rate is also modelled to enable the values of parameters at higher strain rates to be determined by extrapolation. Stress/strain curves at these higher strain rates can then be derived by calculation.

#### 4 Terms and definitions

For the purposes of this document, the terms and definitions given in ISO 527-1 and the following apply.

**4.1**  
**true stress**

$\sigma_T$   
force divided by the cross-sectional area of the specimen within the gauge length at the same time as the force is measured

**4.2**  
**true strain**

$\varepsilon_T$   
incremental increase in the gauge length divided by the gauge length at the same time as the increase is measured

**4.3**  
**true plastic strain**

$\varepsilon_{Tp}$   
true strain at any true stress  $\sigma_T$  minus the elastic component of true strain  $\varepsilon_{Te}$  at that stress

## **5 Apparatus**

### **5.1 Test assembly**

See ISO 527-1:1993, 5.1, for general guidance on apparatus. Servo-hydraulic testing machines usually need to be employed to achieve test speeds above 10 mm/s. At test speeds above around 10 mm/s, errors may arise in the measurement of force. These are associated with the presence of resonance modes in the force transducer, the test specimen and components in the test assembly. To maximize the speed range over which measurements of satisfactory accuracy can be made, attention should be paid to the design of the test assembly so that it incorporates a high stiffness (e.g. piezoelectric) force transducer and components of low mass and high rigidity.

### **5.2 Extensometers**

To maximize the upper limit for the test speed at which accurate measurements are possible, light-weight extensometers or non-contacting devices should be employed. For the measurement of large strains in the specimen, devices capable of defining a small gauge length (typically 4 mm) should be used (see 6.2).

### **5.3 Data-recording equipment**

The data-acquisition rate of the equipment used to record force and extensometer signals shall be high enough to accurately record the shape of the force/extension curve at all test speeds.

## **6 Test specimens**

### **6.1 Low-strain measurements**

For the measurement of properties at strains below the yield strain (see ISO 527-1:1993, 4.7), ISO specimen geometries 1A, 1B or 1BA shall be used. Where specimens are cut from sheet or mouldings, the machining shall be carried out in accordance with ISO 2818.

### **6.2 High-strain measurements**

**6.2.1** At strains above the yield strain, where the stress reaches a maximum or increases only slowly with strain, the strain distribution in the gauge region in standard specimens becomes non-uniform. In extreme situations, this is visible as a neck, and is the reason that International Standards refer to recording the nominal strain (see ISO 527-1:1993, 4.10) through measurements of changes in the grip separation. These strain values have an unknown error which, for some materials, can be very large. Where higher accuracy is

required, an alternative specimen geometry shall be used as shown in Figure 1. This specimen has a uniform thickness but the width is reduced from 10 mm to 8 mm by a circular waist cut at the centre of the specimen length. The specimen thickness is not critical, so it can be machined from the central region of type 1A or 1B specimens or from sheet or mouldings (see ISO 2818). The region of strain localization is now in the centre of the specimen, which is where axial and transverse strains are measured. A gauge length of 4 mm  $\pm$  1 mm shall be used for the measurement of axial strain (see 6.2.2). Transverse strains are needed for the determination of true stresses and these can be measured using transverse extensometers applied to the specimen width or thickness.

**6.2.2** Because of strain localization at strains beyond yield, a small gauge length shall be used in order to achieve a fairly uniform strain distribution in the gauge region. This small gauge length will give rise to a significant reduction in the accuracy of strain measurements at low strains. For this reason, standard specimens are used for the determination of properties at strains below the yield strain (see 6.1). At strains above this, use of the small gauge length with the new specimen in Figure 1 will give strain measurements of satisfactory accuracy.

## 7 Conditioning

See ISO 527-1:1993, Clause 8.

## 8 Test procedure

### 8.1 General

See ISO 527-1:1993, 9.1 to 9.5.

### 8.2 Test speeds

Specimens shall be tested at speeds of 0,1 mm/s, 1 mm/s, 10 mm/s and 100 mm/s. If results at the highest speed are unreliable, or if greater confidence is required in the analysis of results (see 11.2), additional speeds may be used which should be selected from the values 0,3 mm/s, 3 mm/s and 30 mm/s.

### 8.3 Recording of data

Record the force and the changes in the gauge length and width or thickness of the specimen at suitable intervals of time throughout the test.

## 9 Calculation and expression of results

### 9.1 Low-strain measurements

#### 9.1.1 Determination of engineering stresses $\sigma$ , engineering strains $\varepsilon$ , tensile moduli $E$ and Poisson's ratio $\mu$

Using results from type 1A, 1B or 1BA specimens, determine the stress and strain values up to the yield strain for each test speed (see ISO 527-1:1993, 10.1 and 10.2). From these results, calculate the tensile modulus values at each strain rate using the method of ISO 527-1:1993, 10.3. Calculate also an average value for Poisson's ratio for each test over this range of strain (see Note below and ISO 527-1:1993, 10.4).

**NOTE** Whilst tensile modulus and stress/strain curves will vary with the speed of testing, Poisson's ratio will be essentially constant with the test speed and strain up to the yield strain (see Note in 9.2.1).

### 9.1.2 Determination of true stress, $\sigma_T$

Calculate values for the true stress  $\sigma_T$  at each strain  $\varepsilon$  using the equation

$$\sigma_T = \frac{\sigma}{(1 - \mu\varepsilon)^2} \quad (1)$$

where  $\sigma$  is an engineering stress and  $\mu$  is Poisson's ratio calculated from engineering strains.

### 9.1.3 Determination of true strain, $\varepsilon_T$

Calculate values for the true strain  $\varepsilon_T$  using the equation

$$\varepsilon_T = \log_e(1 + \varepsilon) \quad (2)$$

### 9.1.4 Determination of true plastic strain, $\varepsilon_{Tp}$

NOTE For the determination of properties at high strain rates, it is proposed to model measured stress/strain curves and extrapolate parameters to higher strain rates. For this purpose, it is constructive to separate the effects of elasticity and plasticity. It is then possible to identify a function that describes the shape of the curves over a wide range of strain and whereby only one parameter shows any significant variation with strain rate. Furthermore, the separation of elastic and plastic behaviour produces data in a form (hardening functions) required by finite element analyses of deformation of ductile materials.

Calculate values for the true plastic strain  $\varepsilon_{Tp}$  at each strain  $\varepsilon_T$  using the equation

$$\varepsilon_{Tp} = \varepsilon_T - \varepsilon_e = \varepsilon_T - \frac{\sigma}{E} \quad (3)$$

where  $\varepsilon_e$  is the elastic component of strain and there is a small approximation in Equation (3) based on the fact that  $\varepsilon_e \ll 1$  so there is no need to calculate true elastic strains.

### 9.1.5 Determination of plastic strain rate, $\dot{\varepsilon}_{Tp}$

Calculate a value for the effective plastic strain rate for each test by determining the gradient of a plot of the true plastic strain against time at the value for plastic strain corresponding to the peak in stress or, if no peak is observed, the yield stress (see Note below).

NOTE The plastic strain rate will vary throughout a test and will generally increase at a maximum rate in the region of the peak in stress or the yield stress.

### 9.1.6 Determination of elastic strain rate, $\dot{\varepsilon}_e$

Where necessary, a value for the elastic strain rate for each test can be calculated by determining the gradient of a plot of strain against time at small strains where behaviour is linear.

## 9.2 High-strain measurements

### 9.2.1 Determination of stresses, strains and Poisson's ratio $\mu$ vs strain

Using results from specimens of the geometry shown in Figure 1, determine the stress and strain values for each test speed (see ISO 527-1:1993, 10.1 and 10.2). Also, determine curves of Poisson's ratio against strain (see ISO 527-1:1993, 10.4). Select a single curve of Poisson's ratio against strain that is typical of measurements made at each test speed (see Note below).

NOTE Poisson's ratio is a difficult quantity to measure accurately, and large variations in measurements can occur from one test to another. Through repeated measurements of Poisson's ratio, it should be possible to obtain a single curve that is representative of the variation of Poisson's ratio with strain at each strain rate.



### 9.2.2 Determination of true stress, $\sigma_T$

Calculate values for the true stress  $\sigma_T$  at each strain  $\varepsilon$  using Equation (1) in 9.1.2, where  $\mu$  is now the value for Poisson's ratio at the strain  $\varepsilon$ .

### 9.2.3 Determination of true strain, $\varepsilon_T$

Calculate values for the true strain using Equation (2) in 9.1.3.

### 9.2.4 Determination of true plastic strains and plastic strain rates

Calculate values for the true plastic strain at each strain  $\varepsilon_T$  and the effective plastic strain rate for each test as described in 9.1.4 and 9.1.5, respectively.

Dimensions in millimetres

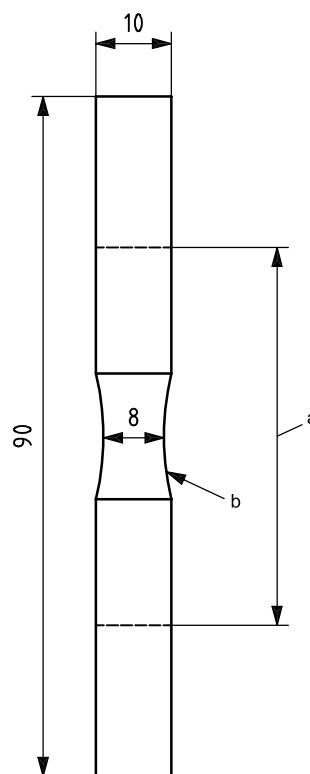

a Grip separation = 50 mm.

b Cut radius = 35 mm.

**Figure 1 — New tensile specimen for the determination of tensile behaviour at high strains**

## 10 Modelling stress versus plastic strain curves

See Note in 9.1.4.

### 10.1 Low-strain measurements

Derive values for the model parameters  $\sigma_0$ ,  $\sigma_f$ ,  $\varepsilon_{op}$  and  $\beta$  that give the best fit, at each test speed, to the data for true stresses  $\sigma_T$  against true plastic strains  $\varepsilon_{Tp}$  determined as described in 9.1 (see Annex A and Note below) by using the equation

$$\sigma_T = \sigma_0 + (\sigma_f - \sigma_0) \left[ 1 - e^{-(\varepsilon_{Tp}/\varepsilon_{op})^\beta} \right] \quad (4)$$

where

$\sigma_0$  is the stress at zero plastic strain and its value is determined by the gradient ( $E$ ) chosen to represent the linear region of a stress/strain curve [see Equation (3)];

$\sigma_f$  is the limiting stress at high plastic strains;

parameters  $\varepsilon_{op}$  and  $\beta$  determine the mean plastic strain and the strain range over which the increase in  $\sigma_T$  with  $\varepsilon_{Tp}$  occurs.

NOTE The parameters in Equation (4) have physical significance. For most plastics,  $\sigma_f$  will be the only parameter that changes significantly with strain rate. The parameter  $\sigma_0$  is expected to increase to a lesser extent with strain rate and, to a good approximation, the ratio  $\sigma_0/\sigma_f$  can be assumed constant. Likewise the parameters  $\varepsilon_{op}$  and  $\beta$  are generally constant within experimental error although, for some materials, small changes in curve shape with strain rate can be accommodated through changes in  $\varepsilon_{op}$ .

### 10.2 High-strain measurements

Use Equation (4) to obtain best fits to the data for true stress and true plastic strains determined over a wide range of strains as described in 9.2. If the fits to the experimental results are not satisfactory at the higher strains, then small changes to Equation (4) can be made to improve the fit (see Annex B).

## 11 Determination of properties over a wide range of strain rates

### 11.1 Tensile modulus

The variation of tensile modulus with strain rate is small for plastics materials at temperatures remote from a relaxation region. For those applications where accurate values are needed at high strain rates, these shall be determined by extrapolation of measured  $E$  values obtained by 9.1.1. For this purpose, the variation of  $E$  with elastic strain rate  $\dot{\varepsilon}$  (see 9.1.6) shall be modelled using the equation

$$E = E_0 (1 - k/\dot{\varepsilon}^n) \quad (5)$$

where  $E_0$ ,  $k$  and  $n$  are parameters that are determined by obtaining the best fit of Equation (5) to experimental data.

### 11.2 Stress/plastic strain curves

#### 11.2.1 General

Stress against plastic strain curves at high strain rates are determined by calculation using Equation (4) in 10.1, or Equation (B.1) or (B.2) in Annex B, with appropriate values for the parameters  $\sigma_f$ ,  $\sigma_0$ ,  $\varepsilon_{op}$  and  $\beta$  at that strain rate. The calculation of curves involves the determination of values for these parameters at high strain

rates by extrapolation as described in 11.2.2 or, if appropriate, 11.2.3. The results of research studies indicate that the extrapolation procedure described gives properties of satisfactory accuracy for at least 2 decades of strain rate above the maximum rate at which measurements are made. This limit, although somewhat arbitrary, is adopted in the analyses that follow. However for some materials, this may be an unnecessarily low limit for the acquisition of valid data.

### 11.2.2 Determination of the parameter $\sigma_f$ (see Note in 10.1)

Plot values for the parameter  $\sigma_f$  (determined as in 10.1 or 10.2) against the logarithm of the plastic strain rate determined as in 9.1.5 or 9.2.4. Obtain the best linear fit to the data, and extrapolate this for 2 decades in strain rate beyond the maximum strain rate at which measurements were made. Determine the value for  $\sigma_f$  at any strain rate within the range defined by the plot, either from the plot or from the equation

$$\sigma_f = \sigma_{f0} + a \log \dot{\epsilon}_{Tp} \quad (6)$$

where the parameter  $\sigma_{f0}$  is the intercept of the line on the stress axis and  $a$  is the gradient.

### 11.2.3 Determination of the parameters $\sigma_0/\sigma_f$ , $\epsilon_{op}$ and $\beta$

Determine a single value for each of these parameters by calculating the mean of the values obtained by fitting Equation (4) to experimental data at different strain rates (see Note below).

**NOTE** As explained in the Note to 10.1, for some materials the parameter  $\epsilon_{op}$  may show a small, but real, variation with strain rate. This can be modelled by assuming a linear dependence of  $\epsilon_{op}$  on  $\log$  (strain rate). Values for  $\epsilon_{op}$  at an arbitrary strain rate can then be determined by interpolation or extrapolation as described for  $\sigma_f$  in 11.2.2.

## 12 Precision

The precision of the properties determined by this International Standard is unknown. It will depend partly on the accuracy of experimental data but also on the quality of the analysis and modelling of these data using Equations (1) to (6). The accuracy of results at high strain rates will depend on the validity of Equations (5) and (6) used for obtaining the values of parameters by extrapolation. Although based on sound physical principles, their validity over a wide range of strain rates and for a variety of plastics materials is not known but can be explored through tests at temperatures below ambient. For these reasons, this International Standard specifies a limit for the extrapolation procedure of 2 decades in strain rate above the maximum value at which measurements were made. This limit is based on available experimental evidence and should be reviewed in future versions of the International Standard.

## Annex A (informative)

### Modelling true stress against true plastic strain curves: Low-strain measurements

Figure A.1 shows measured values for engineering stress against engineering strain for a ductile polymer obtained at test speeds ranging from 0,1 mm/s to 100 mm/s. ISO type 1BA specimens were used. The rates shown with each curve are plastic strain rates obtained in accordance with 9.1.5. The Poisson's ratio result was obtained at the test speed of 0,1 mm/s.

Figure A.2 shows the measured variation of true stress with true plastic strain derived from the data in Figure A.1 using Equations (1), (2) and (3). Values for the parameter  $E$  in Equation (3) were obtained from the gradient to the linear fit to results at low strains.

Figure A.2 also shows how experimental data can be accurately modelled using Equation (4). Values for the parameters in Equation (4) at each test speed are given in Table A.1. It can be seen that only one parameter, the peak stress  $\sigma_f$ , varies significantly with the strain rate.

**Table A.1 — Values for the parameters in Equation (4) used to obtain the fits  
 to tensile data in Figure A.2**

Test speed (mm/s)	Strain rate (s <sup>-1</sup> )	$\sigma_f$ (MPa)	$\sigma_0$ (MPa)	$\varepsilon_{op}$	$\beta$
0,1	0,004	54,5	25	0,004	0,8
1	0,045	59,5	25	0,004	0,8
10	0,35	64	25	0,004	0,8
100	3	67,5	25	0,004	0,8

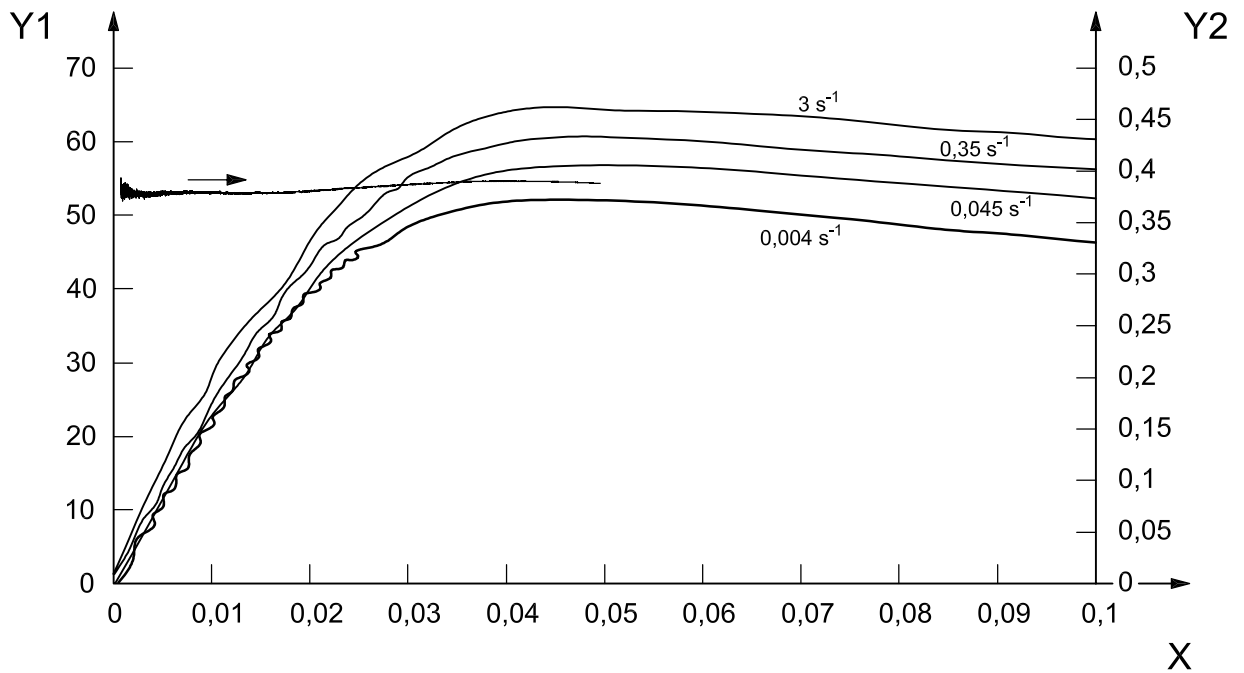

**Key**

- X engineering strain
- Y1 engineering stress, MPa
- Y2 Poisson's ratio

NOTE The Poisson's ratio values were measured at a speed of 0,1 mm/s.

**Figure A.1 — Stress/strain curves measured using type 1BA specimens at speeds of 0,1 mm/s, 1 mm/s, 10 mm/s and 100 mm/s**

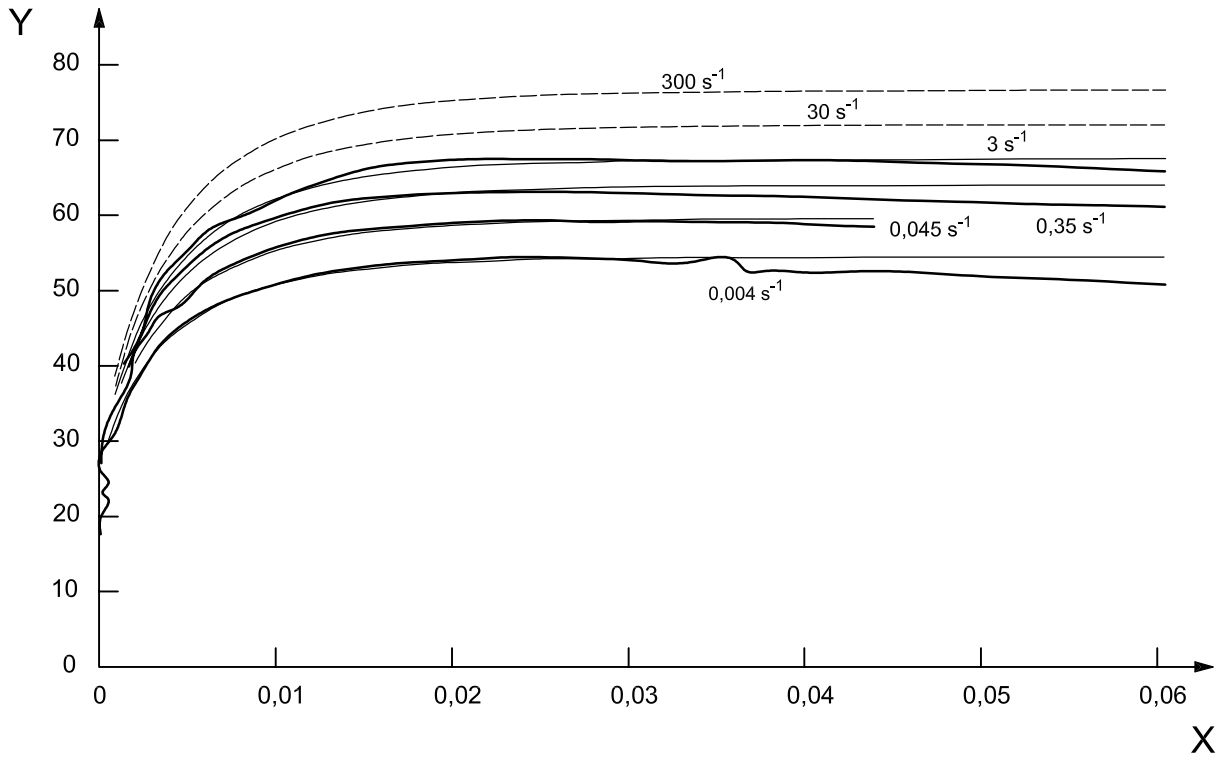

**Key**

X true plastic strain

Y true stress, MPa

— measured values

— modelled using Equation (4)

--- predicted values using Equations (4) and (6)

NOTE The two curves at the highest strain rates were obtained by calculation using Equations (4) and (6).

**Figure A.2 — True stress/true plastic strain curves derived from the data in Figure A.1 using Equations (1), (2) and (3)**

## Annex B (informative)

### Modelling true stress against true plastic strain curves: High-strain measurements

Equation (4) gives a good description of stress/plastic strain curves up to total strains of around 0,06 (plastic strains of around 0,04). This may be satisfactory over a wider strain range for materials that show little change in  $\sigma_T$  with higher plastic strains or for calculations in which the effect of any subsequent variation in  $\sigma_T$  on accuracy can be neglected. However, where a more precise description of the curve shape is needed, this can be achieved by a small modification to Equation (4). Where the stress/plastic strain behaviour shows an approximately linear increase or decrease in stress with plastic strain at higher strains, this can be modelled by a linear function that is added to the expression for  $\sigma_T$  thus

$$\sigma_T = \sigma_0 + (\sigma_f^a - \sigma_0) [1 - e^{-(\varepsilon_{Tp}/\varepsilon_{op})^\beta}] + f \varepsilon_{Tp} \quad (\text{B.1})$$

where  $\sigma_f^a$  is a parameter that replaces  $\sigma_f$  in Equation (4) because of the extra term and the parameter  $f$  is negative if the stress decreases with  $\varepsilon_{Tp}$ . Note that when this term is included, values for the parameter  $\sigma_f^a$  will differ slightly from the value for  $\sigma_f$  obtained using Equation (4).

With most polymers that show a small decrease in stress with plastic strain beyond the stress peak, this is followed by an increase in stress at larger strains which is attributed to the stiffening effect of molecular orientation. Satisfactory curve fits to these data can be obtained by adding a parabolic term to Equation (4) thus

$$\sigma_T = \sigma_0 + (\sigma_f^a - \sigma_0) [1 - e^{-(\varepsilon_{Tp}/\varepsilon_{op})^\beta}] - 2 \frac{\delta}{\varepsilon_{sp}} \varepsilon_{Tp} + \frac{\delta}{\varepsilon_{sp}^2} \varepsilon_{Tp}^2 \quad (\text{B.2})$$

where  $\delta$  and  $\varepsilon_{sp}$  are identifiable parameters:  $\delta$  is the fall in stress after the stress peak and  $\varepsilon_{sp}$  is the plastic strain at the minimum in stress. The flow stress  $\sigma_f^a$  in this equation is again slightly higher than the quantity  $\sigma_f$  in Equation (4) in order to compensate for the reduction in predicted stresses at strains below the stress peak caused by the introduction of the parabolic terms.

Equation (B.2) was used to model results obtained at higher strains as described in 9.2. Figure B.1 shows the fits to experimental data obtained with the parameters listed in Table B.1.

**Table B.1 — Values for the parameters in Equation (B.2)  
used to obtain the fits to tensile data in Figure B.1**

Test speed (mm/s)	Strain rate (s <sup>-1</sup> )	$\sigma_f^a$ (MPa)	$\sigma$ (MPa)	$\varepsilon_{op}$	$\beta$	$\varepsilon_{sp}$	$\delta$ (MPa)
0,1	0,02	58,5	25	0,004	0,8	0,185	4,5
2	0,15	61	25	0,004	0,8	0,185	4,5
10	1,5	65	25	0,004	0,8	0,185	4,5
100	10	70,5	25	0,004	0,8	0,185	4,5

The two curves at the highest strain rate were obtained by calculation using Equation (B.2) with the values for the parameters  $\varepsilon_{op}$ ,  $\varepsilon_{sp}$  and  $\beta$  shown in Table B.1. The appropriate values for  $\sigma_f^a$  at each strain rate were obtained by extrapolation using Equation (6), with  $\sigma_f$  replaced by  $\sigma_f^a$ , to model the variation of  $\sigma_f^a$  with log (strain rate).

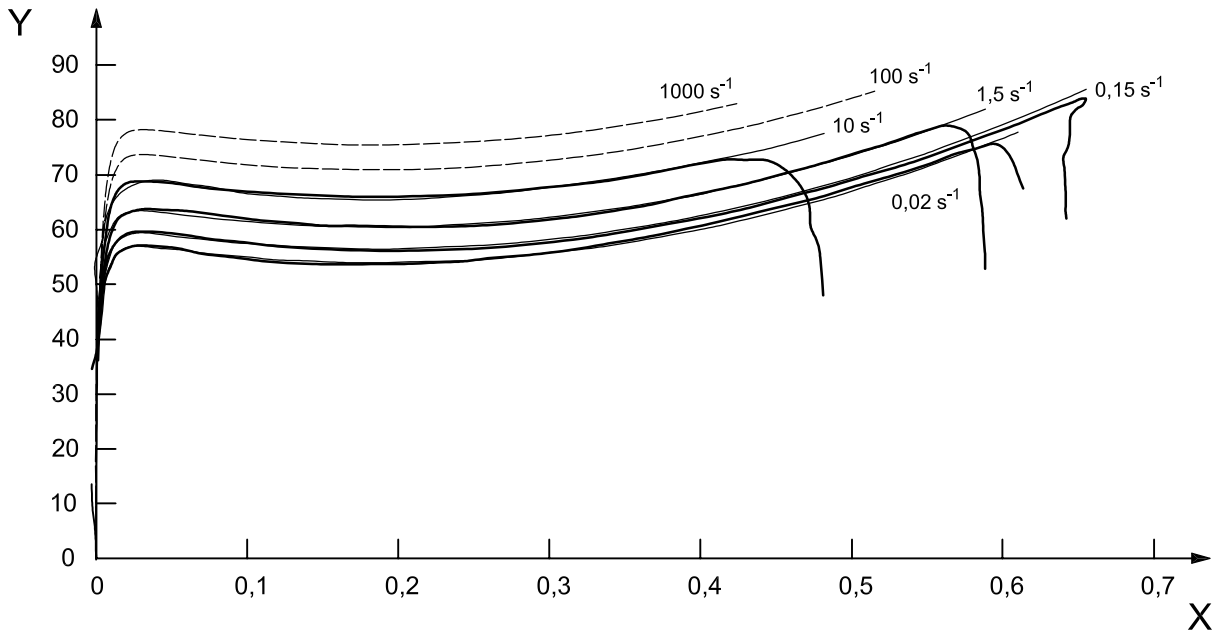

**Key**

X true plastic strain

Y true stress, MPa

— measured values

— modelled using Equation (B.2)

--- values calculated by extrapolation using Equation (6) and calculation using Equation (B.2)

NOTE The two curves at the highest strain rates were obtained by calculation using Equations (6) and (B.2).

**Figure B.1 — True stress/true plastic strain curves measured using specimens with the new geometry shown in Figure 1 and modelled using Equation (B.2)**





## Bureau of Indian Standards

BIS is a statutory institution established under the *Bureau of Indian Standards Act, 2016* to promote harmonious development of the activities of standardization, marking and quality certification of goods and attending to connected matters in the country.

### Copyright

BIS has the copyright of all its publications. No part of these publications may be reproduced in any form without the prior permission in writing of BIS. This does not preclude the free use, in the course of implementing the standard, of necessary details, such as symbols and sizes, type or grade designations. Enquiries relating to copyright be addressed to the Head (Publication & Sales), BIS.

### Review of Indian Standards

Amendments are issued to standards as the need arises on the basis of comments. Standards are also reviewed periodically; a standard along with amendments is reaffirmed when such review indicates that no changes are needed; if the review indicates that changes are needed, it is taken up for revision. Users of Indian Standards should ascertain that they are in possession of the latest amendments or edition by referring to the website-[www.bis.gov.in](http://www.bis.gov.in) or [www.standardsbis.in](http://www.standardsbis.in).

This Indian Standard has been developed from Doc No.: PCD 27 (25106).

### Amendments Issued Since Publication

Amend No.	Date of Issue	Text Affected

## BUREAU OF INDIAN STANDARDS

### Headquarters:

Manak Bhavan, 9 Bahadur Shah Zafar Marg, New Delhi 110002

Telephones: 2323 0131, 2323 3375, 2323 9402

Website: [www.bis.gov.in](http://www.bis.gov.in)

### Regional Offices:

Central : 601/A, Konnectus Tower -1, 6<sup>th</sup> Floor,  
DMRC Building, Bhavbhuti Marg, New  
Delhi 110002

Telephones

{ 2323 7617

Eastern : 8<sup>th</sup> Floor, Plot No 7/7 & 7/8, CP Block, Sector V,  
Salt Lake, Kolkata, West Bengal 700091

{ 2367 0012  
{ 2320 9474

Northern : Plot No. 4-A, Sector 27-B, Madhya Marg,  
Chandigarh 160019

{ 265 9930

Southern : C.I.T. Campus, IV Cross Road, Taramani, Chennai 600113

{ 2254 1442  
{ 2254 1216

Western : 5<sup>th</sup> Floor/MTNL CETTM, Technology Street, Hiranandani Gardens,  
Powai, Mumbai 400076

{ 2570 0030  
{ 2570 2715

**Branches :** AHMEDABAD, BENGALURU, BHOPAL, BHUBANESHWAR, CHANDIGARH, CHENNAI, COIMBATORE, DEHRADUN, DELHI, FARIDABAD, GHAZIABAD, GUWAHATI, HARYANA (CHANDIGARH), HUBLI, HYDERABAD, JAIPUR, JAMMU, JAMSHEDPUR, KOCHI, KOLKATA, LUCKNOW, MADURAI, MUMBAI, NAGPUR, NOIDA, PARWANOO, PATNA, PUNE, RAIPUR, RAJKOT, SURAT, VIJAYAWADA.