

प्लास्टिक — परीक्षण पद्धतियाँ
भाग 8 स्थायी / रासायनिक गुणधर्म
अनुभाग 6 फिल्म और शीटिंग — गैस-संचरण दर
का निर्धारण
उपभाग 2 समान-दबाव विधि
(पहला पुनरीक्षण)

Plastics — Methods of Tests
Part 8 Permanence/Chemical
Properties
Section 6 Film and Sheeting —
Determination of Gas-Transmission Rate
Subsection 2 Equal-Pressure Method
(*First Revision*)

ICS 83.080.01

© BIS 2024
© ISO 2003



भारतीय मानक ब्यूरो
BUREAU OF INDIAN STANDARDS
मानक भवन, 9 बहादुर शाह ज़फर मार्ग, नई दिल्ली - 110002
MANAK BHAVAN, 9 BAHADUR SHAH ZAFAR MARG
NEW DELHI - 110002
www.bis.gov.in www.standardsbis.in

NATIONAL FOREWARD

This Indian Standard (Part 8/Sec 6/Subsec 2) (First Revision) which is identical to ISO 15105-2 : 2003 'Plastics — Film and sheeting — Determination of gas-transmission rate — Part 2: Equal-pressure method' issued by the International Organization for Standardization (ISO) was adopted by the Bureau of Indian Standards on the recommendations of the Methods of Sampling and Test for Plastics Sectional Committee and after approval of the Petroleum, Coals and Related Products Division Council.

This standard was first published in 1997. This revision has been brought out to align the standard with the latest version of ISO 15105-1 : 2007 and ISO 15105-2 : 2003. As the ISO standard is available in two parts, the Committee decided to bifurcate the standards, as given below:

Subsec 1 Differential-pressure methods

Subsec 2 Equal-pressure method

The text of ISO standard has been approved as suitable for publication as an Indian Standard without deviations. Certain conventions are, however, not identical to those used in Indian Standards. Attention is particularly drawn to the following:

- a) Wherever the words 'International Standard' appear referring to this standard, they should be read as 'Indian Standard'; and
- b) Comma (,) has been used as a decimal marker while in Indian Standards, the current practice is to use a point (.) as the decimal marker.

The Committee has reviewed the provisions of the following International Standards referred in this adopted standard and has decided that it is acceptable for use in conjunction with this standard:

<i>International Standard</i>	<i>Title</i>
ISO 4593	Plastics — Film and sheeting — Determination of thickness by mechanical scanning

In reporting the result of a test or analysis made in accordance with this standard, if the final value, observed or calculated, is to be rounded off, it shall be done in accordance with IS 2 : 2022 'Rules for rounding off numerical values (*second revision*)'.

Contents

Page

1	Scope.....	1
2	Normative references	1
3	Terms and definitions	1
4	Principle	2
5	Test specimens	2
6	Conditioning and test temperature	2
7	Apparatus and materials	3
8	Diffusion conditions	4
9	Procedure.....	4
10	Expression of results.....	5
11	Precision	5
12	Test report.....	5
Annex A (normative) Method for the determination of the oxygen-transmission rate using a coulometric sensor		6
Annex B (normative) Detection by gas chromatography		11

Indian Standard

PLASTICS — METHODS OF TESTS
PART 8 PERMANENCE/CHEMICAL PROPERTIES
SECTION 6 FILM AND SHEETING — DETERMINATION OF GAS-TRANSMISSION
RATE
SUBSECTION 2 EQUAL-PRESSURE METHOD
(*First Revision*)

1 Scope

This part of ISO 15105 specifies a method for the determination of the gas-transmission rate of any plastic material in the form of film, sheeting, laminate, co-extruded material or flexible plastic-coated material.

Specific examples, currently in use, of the method are described in the annexes.

2 Normative references

The following referenced documents are indispensable for the application of this document. For dated references, only the edition cited applies. For undated references, the latest edition of the referenced document (including any amendments) applies.

ISO 4593:1993, *Plastics — Film and sheeting — Determination of thickness by mechanical scanning*

3 Terms and definitions

For the purposes of this document, the following terms and definitions apply.

3.1

gas-transmission rate

GTR

volume of gas passing through a plastic material, per unit area and unit time, under unit partial-pressure difference between the two sides of the material

NOTE When the gas used is oxygen, the value obtained is the oxygen-transmission rate (O_2 GTR).

3.2

gas permeability

coefficient of gas permeability

P

volume of gas passing through a plastic material of unit thickness, per unit area and unit time, under unit partial-pressure difference between the two sides of the material

NOTE 1 The theoretical value of P is given by the equation

$$P = \text{GTR} \times d$$

where

P is expressed in mole metres per square metre second pascal [$\text{mol}\cdot\text{m}/(\text{m}^2\cdot\text{s}\cdot\text{Pa})$];

GTR is expressed in moles per square metre second pascal [$\text{mol}/(\text{m}^2 \cdot \text{s} \cdot \text{Pa})$];

d is the average thickness of the specimen, expressed in metres.

NOTE 2 Although P is a physical property of a polymeric material, differences in film preparation affecting polymer orientation and crystal structure will have an effect on the permeation properties.

4 Principle

A test specimen is mounted in a gas-transmission cell (see Figures A.1 and B.1) so as to form a sealed barrier between two chambers. One chamber is slowly swept with a carrier gas. The second chamber is fed with the test gas. The total pressure is identical (atmospheric) in each chamber but, since the partial pressure of the test gas is higher in the second chamber, the test gas permeates through the barrier into the carrier gas in the first chamber.

The test gas which permeates through the specimen is carried by the carrier gas to a sensor the nature of which will depend on the material under test and the test gas used.

5 Test specimens

5.1 Test specimens shall be representative of the material under investigation, free from shrivelling, folds and pinholes, and of uniform thickness. They shall be larger than the gas-transmission area of the measurement cell and be capable of being mounted airtight.

5.2 Use three specimens unless otherwise specified or agreed upon among the interested parties.

5.3 Mark the side of the material facing the permeating gas.

NOTE In principle, the test should replicate the actual conditions of use, with the permeating gas passing from the inside to the outside of e.g. packaging material, or *vice versa*.

5.4 Measure the thickness of each specimen in accordance with ISO 4593, to the nearest $1 \mu\text{m}$, at at least five points distributed over the entire test area, and record the minimum, maximum and average values.

6 Conditioning and test temperature

6.1 Conditioning

The specimens shall be

- either dried for not less than 48 h at the same temperature as that at which the test is to be carried out, using calcium chloride or another suitable drying agent in a desiccator;
- or conditioned at the temperature and humidity specified for the test for a length of time appropriate to the nature of the material under test.

6.2 Test temperature

Carry out the test in a room kept at $23 \text{ }^\circ\text{C} \pm 2 \text{ }^\circ\text{C}$, unless otherwise specified.

7 Apparatus and materials

7.1 General

Figures A.1 and B.1 show examples of apparatus for determining gas-transmission rate.

The apparatus consists of a gas-transmission cell designed to allow a test gas to permeate through a specimen, a sensor to measure the amount of test gas which has permeated through the specimen, and gas-conditioning devices and flowmeters for the test gas and carrier gas.

7.2 Test gas

The test gas may be either a single gas, or a mixture of gases.

In the first case, the pressure of the gas shall be equal to atmospheric pressure.

In the second case, the pressure of the gas shall also be atmospheric and the partial pressure of each individual component will be determined by its concentration in the mixture.

7.3 Transmission cell

7.3.1 The transmission cell is divided into two chambers by a test piece, cut from the sheet of material under test, to allow permeation of the test gas (see 1 in Figures A.1 and B.1).

7.3.2 The test gas flows, under defined conditions, into chamber A and leaves this chamber through a suitably dimensioned outlet at ambient atmospheric pressure.

WARNING — Appropriate precautions should be taken with respect to the use, recovery, recycling and/or disposal of hazardous gases (toxic gases, flammable gases, etc.).

7.3.3 A carrier gas flows through the other chamber (chamber B) of the cell, under defined conditions, such that the pressure difference between the two chambers is as low as possible to prevent distortion of the test piece.

7.3.4 The shape of the cell shall be such that the test specimen is swept on both sides by laminar gas flows.

In particular, the ratio of the effective permeation area to the volume of each chamber shall be such that the velocity of each gas is lower than a specified limit, depending on the shape of the cell.

7.3.5 The effective permeation area shall be adapted according to the range of values to be determined. It is generally between 1 cm² and 150 cm².

The effective permeation area of the test specimen may be reduced by means of a mask placed between the two chambers. In this case, the mask shall be glued on the test specimen and carefully checked for leaks, which would affect the measurements.

7.3.6 When the cell is fitted with gaskets, the material used for the gaskets shall have a gas-transmission rate which is negligible compared to that expected for the material under test.

7.4 Detection and measurement

Of several different methods available for measuring the amount of gas permeating through a specimen, two such methods are described in the annexes:

- Annex A: coulometric sensor (for oxygen-transmission rate);
- Annex B: chromatographic sensor.

NOTE The method used will depend on:

- the permeability of the material to the test gas;
- the sensitivity required.

8 Diffusion conditions

Unless otherwise specified, the test gas and the carrier gas shall be conditioned under one of the sets of conditions of temperature and relative humidity given in Table 1.

Table 1 — Conditions for diffusion

Set of conditions	Temperature °C	Relative humidity %
1	23	0
2	23	50
3	23	60
4	23	75
5	23	85
6	10	85

NOTE 60 % is the relative humidity normally used for conditioning when using a test gas at 0 % RH and a carrier gas at 100 % RH.

9 Procedure

- 9.1 Remove a test specimen from the conditioning atmosphere.
- 9.2 Insert the specimen in the cell.
- 9.3 Inspect the specimen for visual defects such as creases made during insertion.
- 9.4 Connect the cell to the sensor.
- 9.5 Using the two valves immediately upstream of the cell, allow the carrier gas to flow through both chambers, A and B. The gas flow rate is generally set at between 5 ml/min and 100 ml/min.
- 9.6 Inspect the apparatus for leaks, then purge the apparatus completely, taking into account possible desorption from the specimen. Continue to purge the apparatus until a constant signal is received from the sensor.

9.7 Once a constant signal has been obtained, record this value as the zero value.

NOTE The time taken for the apparatus to stabilize may vary from less than one hour to several hours, depending on the material under test, its thickness and the test conditions.

9.8 Allow the test gas to flow into chamber A, under the specified conditions of flow, temperature and humidity. The gas flow rate is generally set at between 5 ml/min and 100 ml/min.

9.9 Proceed until a constant signal is obtained. Record this signal.

9.10 Repeat with the remaining specimens.

10 Expression of results

See Clause A.6 or B.7, depending on the method used.

11 Precision

The precision of these methods is not known because interlaboratory data are not available. When interlaboratory data are obtained, a precision will be added at the following revision.

12 Test report

See Clause A.7 or B.8, depending on the method used.

Annex A (normative)

Method for the determination of the oxygen-transmission rate using a coulometric sensor

A.1 General

This method is used to determine the amount of oxygen permeating through the material, using a coulometric sensor which measures the amount of oxygen which has permeated through the material and been carried out of the cell by the carrier gas.

The sensor generates an electric current proportional to the amount of oxygen flowing through the sensor per unit time.

A.2 Apparatus

Figure A.1 shows a typical apparatus.

Valve 12 bypasses the sensor (9), thus avoiding the cell (1) being swamped with air when the test specimen (2) is being placed in the cell. The valves (7) immediately upstream of the transmission cell allow either carrier gas or test gas to be passed into chamber A of the cell. The catalyst bed (11) is intended to eliminate any traces of oxygen which might be present in the carrier gas.

NOTE Any other suitable means of removing oxygen from the carrier gas is acceptable.

A.3 Carrier gas and test gas

A.3.1 The carrier gas shall be a mixture of dry nitrogen with 0,5 % to 3 % by volume of hydrogen. The volume fraction of oxygen in the carrier gas shall not exceed 100 µl/l.

A.3.2 The test gas shall be dry oxygen containing at least 99,5 % by volume of O₂.

NOTE For materials with a high permeability to oxygen, a mixture of nitrogen and oxygen, such as air (21 % oxygen), may be used. It is also possible to decrease the effective permeation area of the specimen by means of a mask as indicated in 7.3.5.

A.3.3 Gas-conditioning devices (see 4 in Figure A.1) shall be placed upstream of the cell in order to achieve one of the sets of conditions given in Table 1. Devices for monitoring the humidity of the gases may be fitted in the carrier and/or test gas circuits.

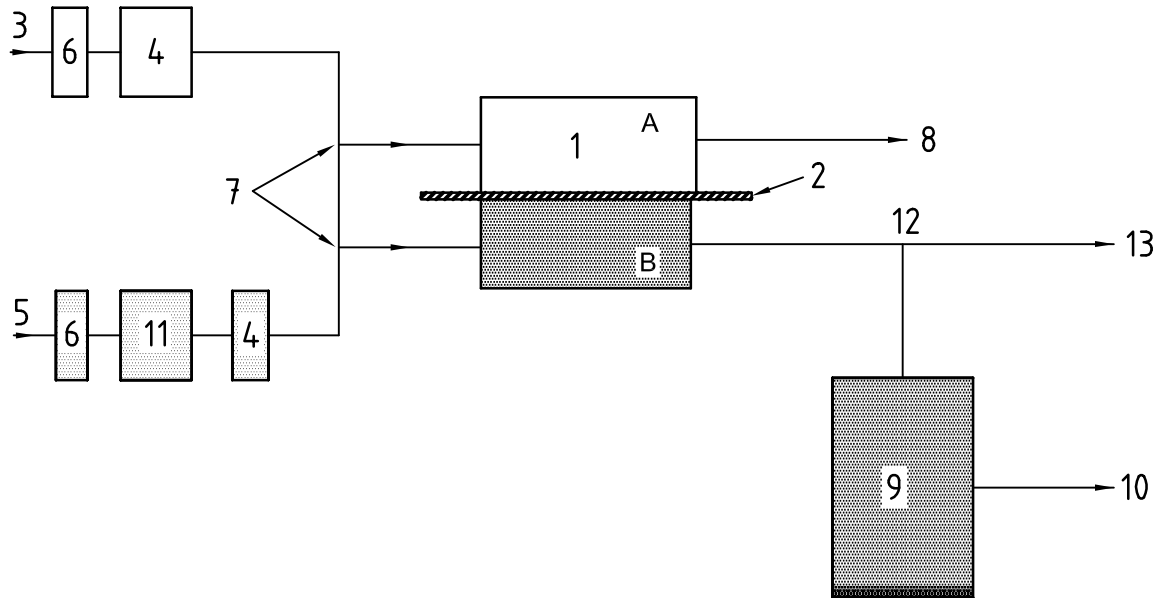

Key

- | | |
|---|---|
| 1 transmission cell with chambers A and B | 8 oxygen outlet (or carrier gas outlet when purging) |
| 2 specimen | 9 coulometric sensor for measurement of O ₂ in carrier gas |
| 3 oxygen inlet | 10 carrier gas outlet |
| 4 gas-conditioning device | 11 catalyst bed, to eliminate traces of O ₂ in carrier gas |
| 5 carrier gas inlet | 12 3-way valve |
| 6 flowmeter | 13 carrier gas outlet when purging the chambers |
| 7 3-way valves | |

Figure A.1 — Typical example of apparatus for determination of oxygen-transmission rate using a coulometric sensor

A.4 Calibration

It is recommended that the sensor be checked periodically against known reference materials.

NOTE The oxygen sensor used in this method is a coulometric device that yields a linear output as predicted by Faraday's law. In principle, the sensor produces four electrons for each molecule of oxygen passing into it. Considering that the sensor is known to have a basic efficiency of 95 % to 98 %, it may be considered an intrinsic standard that does not require calibration, and this method can thus be used as a reference method. However, a sensor may be damaged or may become depleted to the extent that efficiency and response are impaired.

A.5 Procedure

A.5.1 Insert a test specimen, conditioned as indicated in Clause 6, into the transmission cell as indicated in Clause 9, and adjust the test conditions to the values applicable to the material and the specification.

A.5.2 Purge both chambers (A and B), setting the carrier gas flow rate at the following value:

5 ml/min to 25 ml/min for 30 min.

For materials of very low permeability, increase the purge time, setting the carrier gas flow rate at the following values:

25 ml/min to 50 ml/min for the first 3 min to 4 min;

then 5 ml/min to 25 ml/min for the next 30 min.

A.5.3 Inspect the apparatus for leaks.

A.5.4 The electric current generated by the sensor is measured by passing it through a shunt fitted in parallel with a voltage-measuring device. Wait until the sensor signal stabilizes and record this value as the zero value.

A.5.5 Reset the two valves (7) immediately upstream of the cell to allow oxygen to pass through chamber A and wait until a constant signal is obtained. Record the value of this signal.

While some thin films with high transmission rates may reach equilibrium in 30 min to 60 min, thicker or more complex materials may require several hours to reach a steady state of oxygen transmission. Record the time required in the test report.

A.5.6 Repeat the procedure with the remaining specimens.

A.6 Expression of results

A.6.1 Oxygen-transmission rate

The oxygen-transmission rate is calculated using the following equation:

$$O_2GTR = \frac{k(U - U_0)}{A} \times \frac{p_a}{p_O}$$

where

O_2GTR is the oxygen-transmission rate, expressed in moles per square metre second pascal [mol/(m²·s·Pa)];

U is the voltage for the specimen, expressed in volts;

U_0 is the zero-value voltage, expressed in volts;

k is the calibration constant for the apparatus;

p_a is the ambient atmospheric pressure, expressed in pascals;

p_O is the partial pressure of oxygen in the test gas, expressed in pascals;

A is the effective permeation area, expressed in square metres.

NOTE In practice, the voltages U and U_0 include the calibration constant for the apparatus.

A.6.2 Oxygen permeability, or coefficient of oxygen permeability

The gas permeability, or coefficient of permeability, P is a physical characteristic of a polymer material, only depending on the test gas and the test conditions.

The theoretical value of P is given by the equation:

$$P = O_2\text{GTR} \times d$$

where

P is the oxygen permeability, or the coefficient of oxygen permeability, expressed in mole metres per square metre second pascal [(mol·m)/(m²·s·Pa)];

$O_2\text{GTR}$ is the oxygen-transmission rate, expressed in moles per square metre second pascal [mol/(m²·s·Pa)];

d is the thickness of the specimen, expressed in metres.

NOTE 1 $O_2\text{GTR}$ is generally expressed in cubic centimetres per square metre 24 h [cm³/(m²·24 h)], the volume of the gas being converted to standard conditions.

NOTE 2 P is often expressed in cubic centimetre millimetres per square metre 24 h atmosphere [(cm³·mm)/(m²·24 h·atm)]

NOTE 3 d used to be expressed in millimetres.

A.7 Test report

The test report shall include at least:

- a) a reference to this part of ISO 15105;
- b) all details necessary for identification of the test apparatus used (make, manufacturer, etc.);
- c) a description of the test specimens, including:
 - a description of the sample from which the specimens were taken, i.e. film, sheeting, laminate, etc.,
 - the method of preparation, i.e. cast, blown, laminated, etc.,
 - identification of the two sides, if they were different, and a statement as to which side was facing the oxygen;
- d) the number of specimens tested;
- e) the average, minimum and maximum thickness of each specimen;
- f) details of test specimen conditioning;
- g) the effective permeation area;
- h) the temperature of the specimen during the test;
- i) the barometric pressure at the time of the test;
- j) the partial pressure of oxygen in chamber A, and a statement as to how it was determined (see A.3.2);
- k) the rate of flow of the carrier gas during the test;

- l) the time taken to reach the steady state after introduction of oxygen into chamber A of the transmission cell;
- m) the value obtained for the oxygen-transmission rate (and also the permeability P if required) for each specimen tested;
- n) the date of the test.

Annex B (normative)

Detection by gas chromatography

B.1 General

This method is used for the determination of the gas-transmission rate of various gases or mixtures of gases using a gas chromatograph with columns suited to the nature of the gas or gases concerned.

B.2 Principle

Gas molecules which permeate through the test specimen in the transmission cell are carried by the carrier gas to a sampling loop which allows the total contents of the sampling loop to be injected repeatedly into a gas chromatograph.

The peaks in the chromatogram obtained are compared with a calibration graph prepared from chromatograms produced using calibration standards.

NOTE Automatic injection valves may induce a pressure back-up and hence an overpressure in the transmission cell. In such cases, it is necessary to compensate for this overpressure to avoid the test specimen being distorted.

Figure B.1 shows a typical apparatus.

B.3 Chromatograph

B.3.1 General

Various gas-chromatographic columns and detectors are suitable, depending on the test gas involved. Some are described here. Other columns and detectors may be used for specific test gases or to ensure the required sensitivity.

B.3.2 Packed column used with thermal-conductivity detector (TCD)

This equipment is applicable to:

- O₂, CO₂ and/or N₂;
- mixtures of these gases or other gases.

NOTE Gas conditioning (see Table 1) may be carried out upstream of the transmission cell, but it is not advisable to condition the carrier gas when using a TCD sensor.

B.3.3 Packed column used with flame-ionization detector (FID)

This equipment is applicable to:

- CO₂ where high sensitivity is required, the chromatograph being fitted with an upstream methanization oven;
- various organic gases.

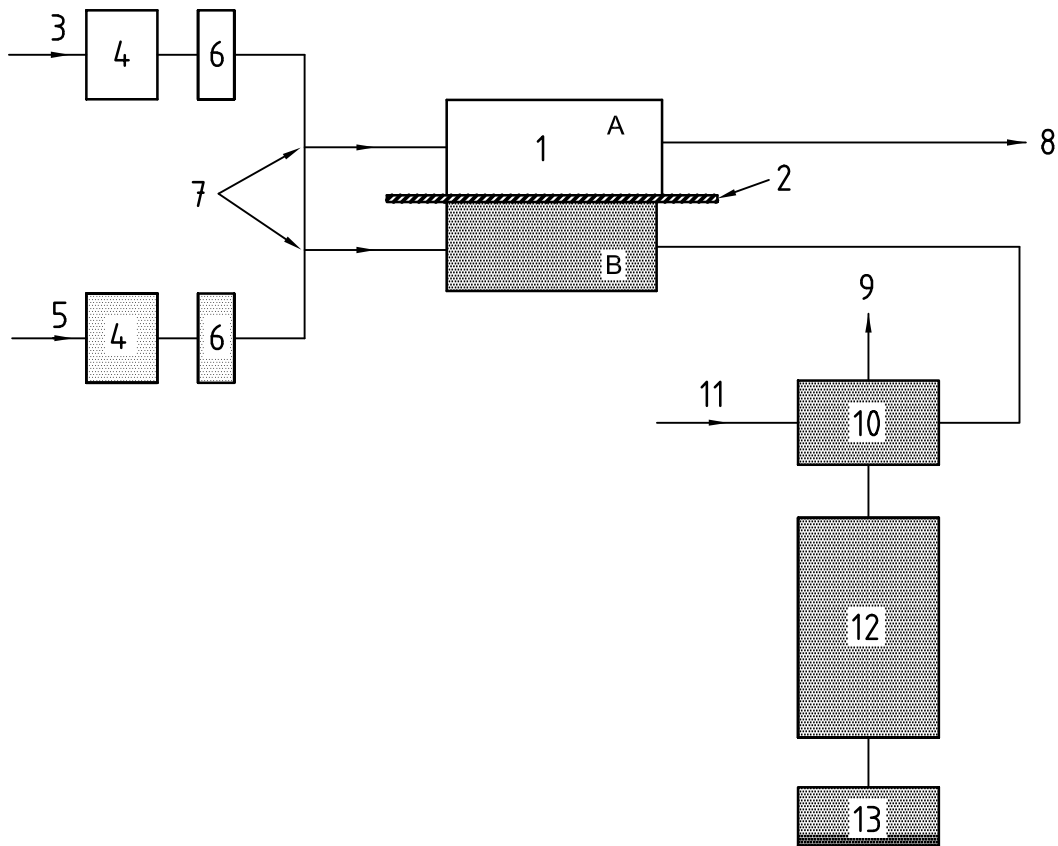

Key

- | | | | |
|---|---|----|--|
| 1 | transmission cell with chambers A and B | 8 | test gas outlet (or carrier gas outlet when purging) |
| 2 | specimen | 9 | carrier gas outlet |
| 3 | test gas inlet | 10 | sampling loop |
| 4 | gas-conditioning device | 11 | chromatography carrier gas inlet |
| 5 | carrier gas inlet | 12 | chromatographic column |
| 6 | flowmeter | 13 | TCD or FID detector |
| 7 | 3-way valves | | |

Figure B.1 —Typical example of apparatus for determination of gas-transmission rate using gas-chromatographic detection

B.3.4 Capillary column used with ionization detector (FID)

This equipment is applicable to high-molecular-mass organic vapours, such as odours or aromas.

In such cases, care shall be taken to avoid condensation of the vapour as it passes through the transmission cell and the chromatographic column and detector.

B.4 Carrier gas and test gas

B.4.1 The carrier gas shall be compatible with the detection equipment.

B.4.2 The concentration of each gas in a mixture of test gases and the purity of the test gas shall be known to within $\pm 1\%$.

B.4.3 Gases shall not contain impurities which may affect the measurements.

B.5 Calibration graph

B.5.1 General

A calibration graph may be obtained for the chromatographic column using one of the following methods.

B.5.2 Method A

B.5.2.1 Order, from specialized suppliers, gas cylinders containing gas mixtures with known concentrations of the gas of interest and covering a concentration range straddling the expected values of the future measurements.

B.5.2.2 Connect each gas cylinder in turn upstream of the sampling loop, and record the chromatogram for each under the same conditions.

B.5.3 Method B

B.5.3.1 This method is applicable to gases which are not present in air.

B.5.3.2 Prepare diluted samples, diluted for instance with air, at different levels of concentration in septum-fitted glass bottles.

B.5.3.3 Using a volumetric syringe, inject a known volume of each of these diluted samples directly onto the column and record the chromatogram for each under the same conditions.

B.5.4 Preparation of calibration graph

For either method, the chromatograms recorded can be used to produce a graph relating the detector signal to the concentration of the gas of interest in the carrier gas.

B.6 Procedure

B.6.1 Carry out the procedure described in Clause 9, feeding the gas which permeates through the test specimen to the sampling loop and injecting samples onto the column in accordance with the chromatograph manufacturer's instructions. Monitor the detector response for the gas of interest, continuing until the detector signal has reached a steady value. Record the time required in the test report.

B.6.2 Using the integrator of the chromatograph, determine the area of the peak in the chromatogram corresponding to the gas of interest.

B.6.3 Determine, from the calibration graph prepared in Clause B.5, the concentration of the gas of interest in the carrier gas.

B.6.4 In parallel, using a calibrated flowmeter (e.g. a soap-bubble flowmeter) determine the flow rate of the carrier gas through the column. This measurement may be performed at the carrier gas outlet (9) after diverting the gas from the column by closing off the sampling loop (10) (see Figure B.1).

B.7 Expression of results

B.7.1 Gas-transmission rate

The gas-transmission rate is calculated using the following equation:

$$\text{GTR} = 1440 \times D \times C \times \frac{10^4}{A} \times \frac{p_a}{p_0}$$

where

GTR is the gas-transmission rate of the gas of interest, expressed in moles per square metre second pascal [mol/(m²·s·Pa)];

D is the carrier gas flow rate, expressed in cubic centimetres per minute;

C is the concentration, by volume, of the gas of interest in the carrier gas, as measured from the chromatogram;

A is the effective permeation area of the test specimen, expressed in square metres;

p_a is the ambient atmospheric pressure, expressed in pascals;

p₀ is the partial pressure of the gas of interest in the test gas, expressed in pascals.

B.7.2 Gas permeability, or coefficient of gas permeability

The gas permeability, or coefficient of permeability, *P* is calculated using the following equation:

$$P = \text{GTR} \times d$$

where

P is the gas permeability, or coefficient of gas permeability, expressed in mole metres per square metre second pascal [(mol·m)/(m²·s·Pa)];

GTR is the gas-transmission rate, expressed in moles per square metre second pascal [mol/(m²·s·Pa)];

d is the average specimen thickness, expressed in metres.

NOTE 1 GTR is generally expressed in cubic centimetres per square metre 24 h [cm³/(m²·24 h)], the volume of the gas being converted to standard conditions under a pressure of one atmosphere.

NOTE 2 *P* is often expressed in cubic centimetre millimetres per square metre 24 h atmosphere [(cm³·mm)/(m²·24 h·atm)]

NOTE 3 *d* used to be expressed in millimetres.

B.8 Test report

The test report shall include at least:

- a) a reference to this part of ISO 15105;
- b) all details necessary for identification of the test apparatus used (make, manufacturer, etc.);
- c) a description of the test specimens, including:

- a description of the sample from which the specimens were taken, i.e. film, sheeting, laminate, etc.,
 - the method of preparation, i.e. cast, blown, laminated, etc.,
 - identification of the two sides, if they were different, and a statement as to which side was facing the oxygen;
- d) the number of specimens tested;
 - e) the average, minimum and maximum thickness of each specimen;
 - f) details of test specimen conditioning;
 - g) the effective permeation area;
 - h) the temperature of the specimen during the test;
 - i) the barometric pressure at the time of the test;
 - j) the nature of the test gas or, if applicable, the composition of the mixture of gases together with a statement as to how the composition was determined;
 - k) the rate of flow of the carrier gas during the test;
 - l) the time taken to reach the steady state after introduction of test gas into chamber A of the transmission cell;
 - m) the value obtained for the gas-transmission rate (and also the permeability P if required) for each specimen tested;
 - n) the date of the test.

Bureau of Indian Standards

BIS is a statutory institution established under the *Bureau of Indian Standards Act, 2016* to promote harmonious development of the activities of standardization, marking and quality certification of goods and attending to connected matters in the country.

Copyright

BIS has the copyright of all its publications. No part of these publications may be reproduced in any form without the prior permission in writing of BIS. This does not preclude the free use, in the course of implementing the standard, of necessary details, such as symbols and sizes, type or grade designations. Enquiries relating to copyright be addressed to the Head (Publication & Sales), BIS.

Review of Indian Standards

Amendments are issued to standards as the need arises on the basis of comments. Standards are also reviewed periodically; a standard along with amendments is reaffirmed when such review indicates that no changes are needed; if the review indicates that changes are needed, it is taken up for revision. Users of Indian Standards should ascertain that they are in possession of the latest amendments or edition by referring to the website-www.bis.gov.in or www.standardsbis.in.

This Indian Standard has been developed from Doc No.: PCD 27 (23127).

Amendments Issued Since Publication

Amend No.	Date of Issue	Text Affected

BUREAU OF INDIAN STANDARDS

Headquarters:

Manak Bhavan, 9 Bahadur Shah Zafar Marg, New Delhi 110002

Telephones: 2323 0131, 2323 3375, 2323 9402

Website: www.bis.gov.in

Regional Offices:

	Telephones
Central : 601/A, Konnectus Tower -1, 6 th Floor, DMRC Building, Bhavbhuti Marg, New Delhi 110002	{ 2323 7617
Eastern : 8 th Floor, Plot No 7/7 & 7/8, CP Block, Sector V, Salt Lake, Kolkata, West Bengal 700091	{ 2367 0012 2320 9474
Northern : Plot No. 4-A, Sector 27-B, Madhya Marg, Chandigarh 160019	{ 265 9930
Southern : C.I.T. Campus, IV Cross Road, Taramani, Chennai 600113	{ 2254 1442 2254 1216
Western : 5 th Floor/MTNL CETTM, Technology Street, Hiranandani Gardens, Powai Mumbai 400076	{ 25700030 25702715

Branches : AHMEDABAD, BENGALURU, BHOPAL, BHUBANESHWAR, CHANDIGARH, CHENNAI, COIMBATORE, DEHRADUN, DELHI, FARIDABAD, GHAZIABAD, GUWAHATI, HARYANA (CHANDIGARH), HUBLI, HYDERABAD, JAIPUR, JAMMU, JAMSHEDPUR, KOCHI, KOLKATA, LUCKNOW, MADURAI, MUMBAI, NAGPUR, NOIDA, PARWANOO, PATNA, PUNE, RAIPUR, RAJKOT, SURAT, VIJAYAWADA.