

कठोर धातुओं के अपघर्षक घिसाव प्रतिरोध के
निर्धारण — पद्धतियाँ

(पहला पुनरीक्षण)

Determination of Abrasive Wear
Resistance of Hard Metals —
Methods

(First Revision)

ICS 77.160

© BIS 2024
© ISO 2021



भारतीय मानक ब्यूरो
BUREAU OF INDIAN STANDARDS
मानक भवन, 9 बहादुर शाह ज़फर मार्ग, नई दिल्ली - 110002
MANAK BHAVAN, 9 BAHADUR SHAH ZAFAR MARG
NEW DELHI - 110002

www.bis.gov.in www.standardsbis.in

NATIONAL FOREWORD

This Indian Standard (First Revision) which is identical to ISO 28080 : 2021 'Hard metals — Abrasion tests for hard metals' issued by the International Organization for Standardization (ISO) was adopted by the Bureau of Indian Standards on the recommendation of the Powder Metallurgical materials and Products Sectional Committee and approval of the Metallurgical Engineering Division Council.

This standard was published in 1988 and This revision of this standard has been brought out to align with the latest version of ISO 28080 : 2021 under dual numbering system to harmonize it with the latest developments that have taken place at international level.

Former title of the Indian Standard IS 12286 : 1988 was 'Method for determination of abrasive wear resistance of hard metals' which is change to 'Hard metals — Abrasion tests for hard metals' as per the title of ISO 28080 : 2021

This document provides new and improved methods for testing the abrasion characteristics of hard metals using rotating-wheel systems. There are a number of abrasion test methods that have been developed that use this type of geometry, including the dry sand/rubber wheel test, the wet sand/rubber wheel test and the steel wheel test. All of these tests use a rotating wheel pressed against a test piece, with abrasive material introduced between the wheel and the test piece. Because of this fundamental commonality, much of the methodology is the same for the different tests. However, they do differ in the details of how the abrasive is fed to the interface between the wheel and the test piece, if the test can be carried out in the presence of fluids, and if the abrasive is only used once and passes through the test system, or is reused many times.

The text of ISO standard has been approved as suitable for publication as in Indian Standard without deviations. Certain terminologies and conventions are, however, not identical with those used in Indian Standard. Attention is especially drawn to the following:

- a) Wherever the words 'International Standard' appear referring to this standard, it should be read as 'Indian Standard'; and
- b) Comma (,) has been used as a decimal marker while in Indian Standards the current practice is to use a point (.) as the decimal marker.

In this adopted standard, reference appears to certain International Standards for which Indian Standards also exists. The corresponding Indian Standards which are to be substituted in their place are listed below along with their degree of equivalence for the edition indicated:

<i>International Standard</i>	<i>Corresponding Indian Standard</i>	<i>Degree of Equivalence</i>
ISO 3369 : 2006 Impermeable sintered metal materials and hard metals — Determination of density	IS 4841 : 2022/ISO 3369 : 2006 Impermeable sintered metal materials and hard metals — Determination of density (second revision)	Identical

The Committee has reviewed the provisions of the following International Standard, referred in this adopted standard and has decided that it is acceptable for use in conjunction with this standard:

<i>International Standard</i>	<i>Title</i>
ASTM B611 : 2021	Standard test method for determining the high stress abrasion resistance of hard materials

(Continued on third cover)

Contents

Page

Introduction	iv
1 Scope	1
2 Normative references	1
3 Terms and definitions	1
4 Principle	2
5 Materials	2
5.1 Test pieces.....	2
5.1.1 Overall sizes.....	2
5.1.2 Surface finish.....	2
5.2 Abrasive.....	2
5.3 Reference materials.....	2
5.4 Wheel.....	3
5.4.1 Material.....	3
5.4.2 Wheel size.....	3
6 Apparatus	3
6.1 Summary of apparatuses (test systems).....	3
6.2 Abrasive-feed mechanism.....	4
6.3 Vacuum extraction.....	4
6.4 Control of wheel speed.....	5
6.5 Calibration of abrasive flow.....	5
6.6 Test load.....	5
6.7 Fluid flow.....	5
6.8 Instrumentation.....	5
7 Preparation of test piece	6
7.1 Test-piece cleaning.....	6
7.2 Test-piece weighing.....	6
7.3 Test-sample density.....	6
8 Procedure	7
8.1 General.....	7
8.2 Test-piece clamping.....	7
8.3 Typical operation conditions.....	7
8.4 Start of test.....	7
8.5 End of test or test stop.....	7
8.6 Interrupted tests.....	8
8.7 Use of a reference material.....	8
8.8 Number of repeat tests.....	8
9 Expression of results	8
9.1 Single-step test.....	8
9.2 Multiple-step test.....	8
9.2.1 Tabulation.....	8
9.2.2 Calculation of abrasion rate.....	9
9.3 Illustration of trends of wear, friction force and normal force.....	9
9.4 Illustration of comparative set of measurements using two abrasion materials.....	9
10 Uncertainty of measurement	10
11 Test report	11
Bibliography	13

Introduction

This document provides new and improved methods for testing the abrasion characteristics of hardmetals using rotating-wheel systems. There are a number of abrasion test methods that have been developed that use this type of geometry, including the ASTM G65 dry sand/rubber wheel test, the ASTM G105 wet sand/rubber wheel test and the ASTM B611 steel wheel test. Other variants of these tests have also been developed for specific applications in other institutes. All of these tests use a rotating wheel pressed against a test piece, with abrasive material introduced between the wheel and the test piece. Because of this fundamental commonality, much of the methodology is the same for the different tests. However, they do differ in the details of how the abrasive is fed to the interface between the wheel and the test piece, if the test can be carried out in the presence of fluids, and if the abrasive is only used once and passes through the test system, or is reused many times.

This document provides framework that brings together the key features of these tests and gives results that show comparability. It also gives information on their reproducibility and repeatability.

The procedure complements the ASTM G65 method for dry sand/rubber wheel abrasion, the ASTM B611 method for determining the high stress abrasion of hard materials, and the ASTM G105 method for conducting wet sand/rubber wheel abrasion tests.

Abrasion wear is not a measure of the wear characteristics of hardmetals under all conditions, and should not be misinterpreted as indicating wear when hardmetals are used for tooling, such as cutting and milling. It does show the difference in resistance to abrasive use for different carbide compositions, and the methods may be used as practical tests or as research methods for material discrimination.

Indian Standard

DETERMINATION OF ABRASIVE WEAR RESISTANCE OF HARD METALS — METHODS

1 Scope

This document specifies a generic test method to determine the abrasion wear characteristics of hardmetals.

The test is appropriate for use in situations where test laboratories have a need to simulate abrasive damage. The procedure includes information which enables the test to be used in a variety of different conditions:

- a) with counterface wheels of different stiffness (for example steel and rubber);
- b) wet and dry;
- c) different abrasive sizes;
- d) different chemical environments.

2 Normative references

The following documents are referred to in the text in such a way that some or all of their content constitutes requirements of this document. For dated references, only the edition cited applies. For undated references, the latest edition of the referenced document (including any amendments) applies.

ISO 3369, *Impermeable sintered metal materials and hardmetals — Determination of density*

ASTM B611, *Standard Test Method for Determining the High Stress Abrasion Resistance of Hard Materials*

ASTM G65, *Standard Test Method for Measuring Abrasion Using the Dry Sand/Rubber Wheel Apparatus*

ASTM G105, *Standard Test Method for Conducting Wet Sand/Rubber Wheel Abrasion Tests*

3 Terms and definitions

For the purposes of this document, the following terms and definitions apply.

ISO and IEC maintain terminological databases for use in standardization at the following addresses:

- ISO Online browsing platform: available at <https://www.iso.org/obp>
- IEC Electropedia: available at <http://www.electropedia.org/>

3.1

abrasion volume loss

V

test piece's loss in volume during the test

Note 1 to entry: In ASTM B611, this is defined as the volume loss per revolution of the steel wheel.

3.2

abrasion wear

wear caused by an abrasive material on a rotating surface contacting the test-piece surface under pressure

4 Principle

The test uses a rotating wheel against which test pieces are pressed. Abrasive is introduced between the wheel and the test piece to cause abrasion to the test piece.

5 Materials

5.1 Test pieces

5.1.1 Overall sizes

Test pieces are typically larger than the contact area with the rotating wheel and are typically 40 mm to 70 mm × 20 mm to 25 mm in size. These test pieces are designed to allow for the wear scar to be contained wholly within the area of the contact face. However, some variants of the test (see Reference [1]) use a test piece with a clearly defined contact shape and size where the wear takes place across the entire contact face of the sample. The thickness of the test piece is not important, as long as it is sufficiently robust and the wear takes place entirely within the test piece.

When coated samples are tested, the test duration is normally adjusted to ensure that the wear occurs exclusively within the coating. This can be determined by post-test examination.

5.1.2 Surface finish

The surface finish of the test piece can affect the results of the test. Thus, the presence of a surface that is weakened by the preparation process can lead to increased initial wear. Conversely, the presence of a residual compressive stress in the surface layer can possibly reduce initial wear. In both cases when these surface regions are worn away, the wear rate is expected to approach the normal value for the material.

5.2 Abrasive

The test abrasive shall be obtained from a consistent source with good quality control procedures, to ensure that variability in its properties is minimized.

It is well known that the results of abrasion testing depend critically on the shape, size and size distribution of the abrasive. For this reason, if it is important to compare the results of one test with another, the same abrasive should be used in the tests concerned.

It is important that the abrasive be dry and free flowing to avoid blockage of the test system. The moisture content of the abrasive should be less than 1 % by mass. The moisture content can be measured by weighing a sample, heating to 105 °C for an hour, cooling in a desiccator, and reweighing. The percent mass loss is assumed to be moisture. If necessary, it should be dried in an oven before use.

ASTM B611 uses coarse alumina as an abrasive, and ASTM G65 and ASTM G105 use silica sand. For further specific details of the abrasives, see ASTM B611, ASTM G65 and ASTM G105.

5.3 Reference materials

It is also effective, in some circumstances, to use a reference material in a sequence of tests to normalize test results to take account of minor uncontrolled variations in test conditions or changes in the make-up of the abrasive. This procedure is described in [8.7](#).

In any case, a test should be carried out periodically on a reference material to ensure that the test system is operating correctly and gives repeatable results.

5.4 Wheel

5.4.1 Material

Either the wheel is made from a solid piece of the requisite material such as steel, or, when elastomeric materials are being used to provide a compliant surface, a rim of the necessary elastomer is normally moulded onto the rim of a steel wheel. Suitable wheels of AISI 1020 grade steel as specified in ASTM B611 and chlorobutyl rubber or neoprene rimmed wheels with a Shore A Durometer hardness as specified in ASTM G65 or in ASTM G105 shall be used.

Moulded polyurethane or other artificial elastomer rims may also be used, but it should be noted that, even if the same ambient temperature hardness is achieved for the polyurethane as for the above-specified rubber, significant differences in results can occur in dry tests, possibly due to alteration of mechanical properties relative to those of the rubber due to heating by the abrasion process.

5.4.2 Wheel size

The wheel specified in ASTM G65 has a diameter of 228,6 mm and a face width of 12,7 mm and in ASTM B611 it has a maximum diameter of 169 mm and width of 12,7 mm. There are other test systems of a similar type which have wheels of different size, but unless there are special reasons to choose otherwise, the specific test conditions in the ASTM standards should be used. For tests which use rubber elastomer rims, such as ASTM G65, the thickness of the rim should be 12,7 mm. Again, if there are no special reasons to choose otherwise, the ASTM G65 conditions should be used.

The wheel is subjected to damage during the testing, and should be checked periodically. If significant damage has occurred, the wheel should be replaced. The overall diameter of the wheel should also be checked and, when it is reduced in size by the recommended amount (12,7 mm for ASTM G65 and 4 mm for ASTM B611), the wheel should be replaced.

The rubber wheel should be dressed accordingly before each test.

The flatness and squareness of the contact area on the wheel are most easily checked by examining a wear scar (see [Figure 3](#)). If this is even and regular, then the contact is flat and square.

6 Apparatus

6.1 Summary of apparatuses (test systems)

The schematics of typical test systems are shown in [Figure 1](#). Two variants are shown, Variant 1 (see References [2] and [3]) where the test piece is horizontal and pressed into the top of the wheel, and Variant 2 (see Reference [4]) where the test piece is held vertically and pressed into the edge of the wheel.

NOTE Examples of Variant 2 test systems are the ASTM B611 test and the ASTM G65 test.

The abrasive is fed from a hopper into the abrasive-feed system and thence into the contact between the test piece and rotating wheel.

The test conditions can also be varied by adding a supply of fluid just in front of the abrasive feed, or by immersing the wheel in a bath of fluid that wets the wheel.

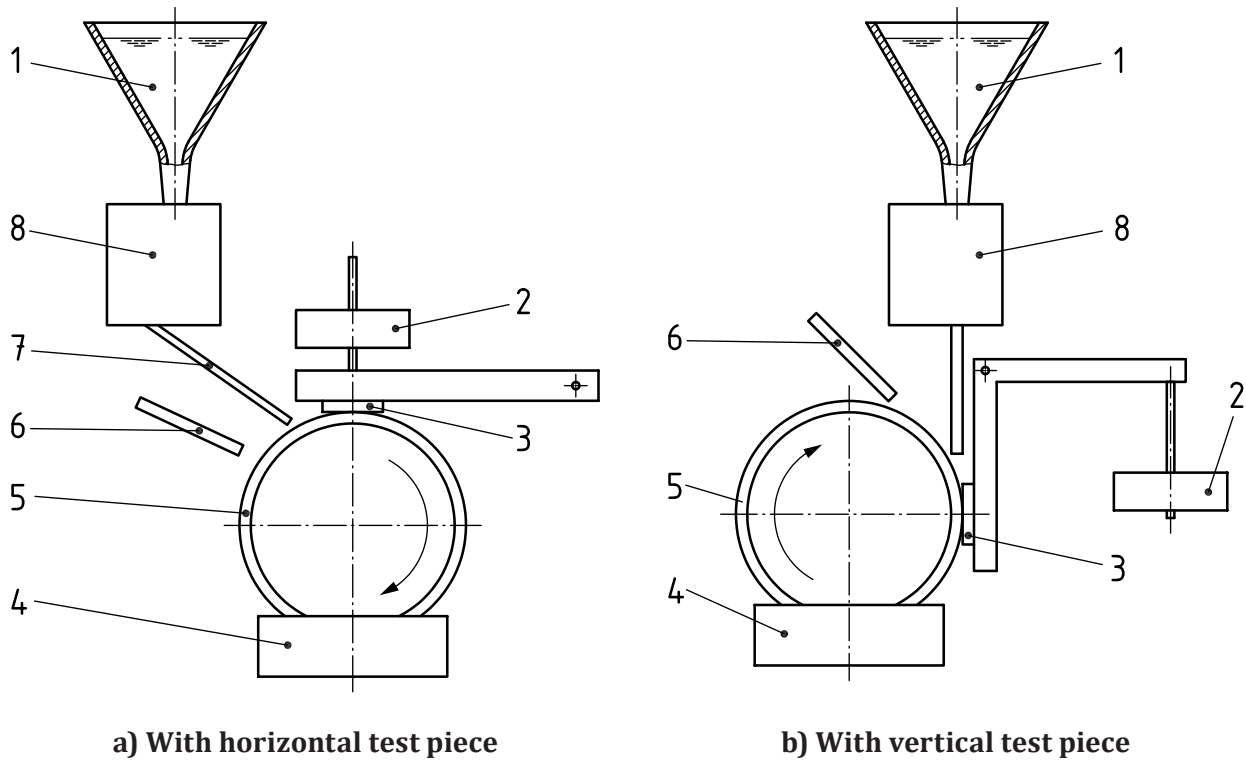

Key

- | | | | |
|---|-------------|---|-------------------------|
| 1 | abrasive | 5 | rubber rim |
| 2 | weight | 6 | fluid feed |
| 3 | sample | 7 | feed chute |
| 4 | slurry bath | 8 | abrasive-feed mechanism |

NOTE Abrasive can be fed by means of a slurry bath or by means of an abrasive feed from a hopper. Both types of supply are not required. In addition, the fluid is not required for dry tests.

Figure 1 — Schematic diagram of rotating-wheel abrasion test system with horizontal test piece or vertical test piece

6.2 Abrasive-feed mechanism

The abrasive can be fed to the test piece, respectively wheel interface, by a number of different methods. These include

- a) a vibrating feed,
- b) a screw auger, and
- c) a slotted rotating disc to control flow coupled with a chute.

The essential feature of all these methods is that the abrasive is fed steadily and in a well-controlled way to the test piece, respectively wheel interface. All of these methods have been shown to be effective in giving good control of feed rates.

6.3 Vacuum extraction

It is important that, for dry tests, a vacuum extraction system with the appropriate HSE filters be fitted to ensure that any used fine debris from the abrasive test piece that can be a health risk is collected and can subsequently be disposed of safely.

6.4 Control of wheel speed

The wheel speed needs to be well controlled with a motor of adequate power such that a stable constant speed is achieved independent of the load applied. The rotational speed shall be calibrated periodically (once per year is recommended) to ensure stable operation.

6.5 Calibration of abrasive flow

The abrasive flow is clearly a critical parameter in the testing. This needs to be carefully measured. It is important to ensure that only the abrasive that actually passes through the wearing contact is measured. This is normally achieved by arranging a series of baffles to divert away any abrasive that does not pass through the contact, so that only the abrasive that does pass through is measured by collecting and weighing for a pre-determined period and calculating a rate of abrasive flowrate.

Some test systems (see References [1] and [5]) are specifically designed to ensure that all the abrasive passes through the test contact. In these systems, the abrasive flow rate can be calculated by a simple measurement of all the abrasive passing through the contact.

To enable a comparison of abrasion loading to be carried out from one rig to another, the abrasive flowrate can be converted to an abrasive coverage figure with [Formula \(1\)](#).

$$C_a = \frac{Q}{A_c} \quad (1)$$

where

C_a is the abrasive coverage figure, in cubic metres per square metre seconds ($\text{m}^3 \text{m}^{-2} \text{s}^{-1}$);

Q is the volume flowrate, in cubic metres per second ($\text{m}^3 \text{s}^{-1}$);

A_c is the abrasive coverage, in square metres (m^2).

This procedure is only useful where the counterface is compliant, so that the contact area does not increase markedly as wear takes place during the test.

6.6 Test load

Normally, dead-weight loading is applied through a lever-arm system. However, other types of loading system can be used effectively. The actual load applied should be calibrated before use of the test system and should be checked periodically (typically once per year or every 200 tests).

6.7 Fluid flow

In systems fitted with a fluid feed, the flowrate shall be calibrated before use. This is normally done by simple gravimetric procedures.

6.8 Instrumentation

Some test systems used to carry out abrasion tests on hardmetals are instrumented to measure and store other test results, such as the friction force (F_F), normal force (F_N), and depth of wear (D), during the test run. Acquisition of measured values is carried out by means of appropriate signal conditioning, an analogue-to-digital converter, and a personal computer. F_F is measured by a suitably mounted load cell, F_N is measured by a load cell integrated in the lever arm, and D is measured by a displacement transducer placed in such a way as to monitor the movement of the test wheel into the sample.

An example of a test system that incorporates these features is shown in [Figure 2](#).

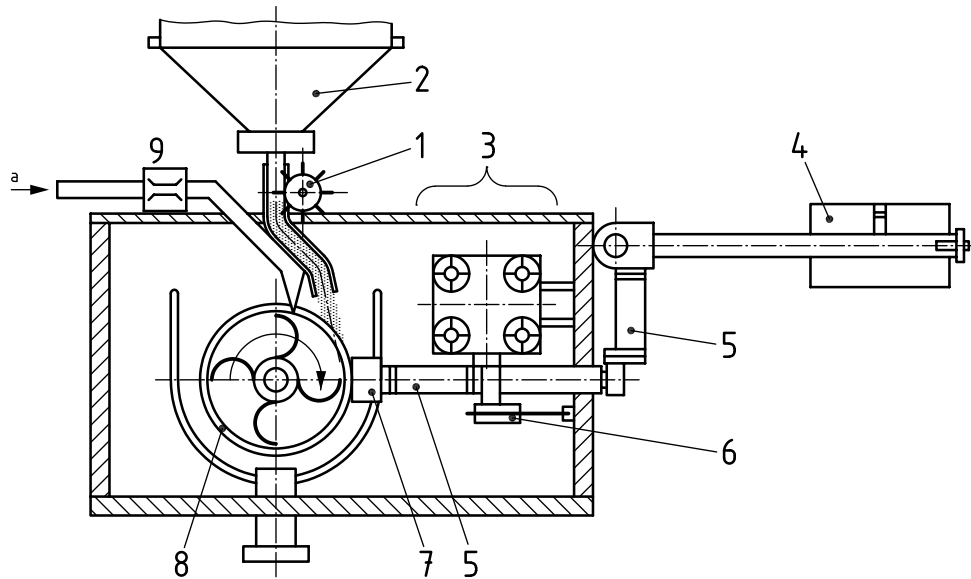

Key

- 1 bucket wheel
- 2 supply vessel
- 3 linear bearing
- 4 weight and lever arm
- 5 load cells
- 6 displacement transducer
- 7 sample
- 8 rotating wheel
- 9 flowmeter
- a Water.

Figure 2 — Three-body abrasion apparatus for wear resistance — Combination of ASTM Standards G65 and B611

7 Preparation of test piece

7.1 Test-piece cleaning

The test piece shall be cleaned before placing in the test system by cleaning ultrasonically in acetone for 10 min.

7.2 Test-piece weighing

The mass of the test piece shall be measured before the test with a balance that can measure to 0,1 mg.

7.3 Test-sample density

The test-sample density shall be determined in accordance with ISO 3369.

8 Procedure

8.1 General

Either tests can be carried out with a single step of a relatively long duration, or an interrupted test can be carried out with a number of abrasion steps of shorter duration, with the test piece reweighed between each step.

The interrupted test can be useful to determine if transitions in wear are encountered, for instance, due to the effect of surface damage to the test piece. However, it should be noted that there is a possibility that interrupted tests can give different results to a non-interrupted test of the same duration. This possibility is due to the disturbance of the surface during the cleaning and reweighing process at the end of each step, and the possible effect of not being able to replace the test piece exactly from one step to the next.

8.2 Test-piece clamping

The test piece is clamped in position in the test system. The alignment of the test piece shall be checked and adjusted, if necessary, to give a flat contact across the width of the wheel.

8.3 Typical operation conditions

The operating conditions for the test should be designed to match the conditions that occur in the application that is being simulated. In the absence of this information, the following conditions have been found to give useful results:

- a) load of 130 N;
- b) speed of 1 ms⁻¹;
- c) abrasive flow rate of 150 g/min through contact;
- d) test duration of 20 min.

Other specific operating conditions are given in ASTM B611, ASTM G65 or ASTM G105.

8.4 Start of test

The test piece shall be lifted off the wheel. The motor should be started and the speed of the wheel allowed to stabilize. The abrasive flow shall be switched on and allowed to stabilize before the test piece is lowered gently against the wheel and the test is started.

If an instrumented test system is being used, the data acquisition system should be started before the sample is brought into contact with the test wheel.

8.5 End of test or test stop

At the specified contact duration, the motor and abrasive flow should be switched off. If an instrumented test system is being used, the data acquisition should be stopped just after the motor and abrasive flow. The test piece shall be removed and cleaned as described in [7.1](#) before being reweighed.

It is worth examining the test piece by eye to check if the wear scar is even in shape (see [Figure 3](#)). If this is not the case, the alignment of the test system and the wheel shape shall be checked and the test repeated.

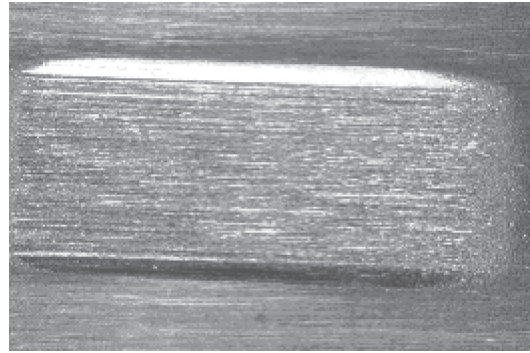

Figure 3 — Even wear scar formed on test piece with steel wheel and silica abrasive

8.6 Interrupted tests

For tests where a sequence of steps is carried out for small durations, with the test piece reweighed after each step followed by replacing in the test system and another test step, the procedures in [Clause 7](#), [8.4](#) and [8.5](#) should be repeated until the required total test duration has been achieved. Normally, this consists of at least 5 steps.

8.7 Use of a reference material

If the results of the test are going to be compared to the results obtained with a reference material, then a test should be carried out under the same conditions. The ratio of the wear rate for the test material to the wear rate of the reference material is then calculated.

8.8 Number of repeat tests

At least two repeat tests shall be carried out under the same conditions for each material.

9 Expression of results

9.1 Single-step test

The mass loss, M , in kilograms (kg), is calculated by subtracting the value of mass measured at the end of the test from the initial mass. This is converted to a volume loss, V , in cubic metres (m^3), using [Formula \(2\)](#), by using the measured test-piece density, ρ , in kilograms per cubic metre (kg m^3).

$$V = \frac{M}{\rho} \quad (2)$$

9.2 Multiple-step test

9.2.1 Tabulation

The values of mass measured in [7.2](#) are tabulated, the mass losses calculated by subtracting these values from the initial mass, and a table of mass loss against mass of abrasive calculated using a spreadsheet or equivalent program. The test-piece mass loss is converted to a volume loss by using the measured test-piece density. The abrasion volume loss is normally presented as a graph with respect to the mass of abrasive.

9.2.2 Calculation of abrasion rate

Regression analysis shall be used to obtain an abrasion rate for the material under the conditions of the test. It is important that this regression analysis only include data points from the linear portion of the data.

9.3 Illustration of trends of wear, friction force and normal force

If an instrumented test system is used then the trends of depth of wear, friction force and normal force should be plotted as in [Figure 4](#).

9.4 Illustration of comparative set of measurements using two abrasion materials

An example of the results of a comparative set of measurements using two abrasive materials [alumina and silica (sand)] is given in [Figure 5](#).

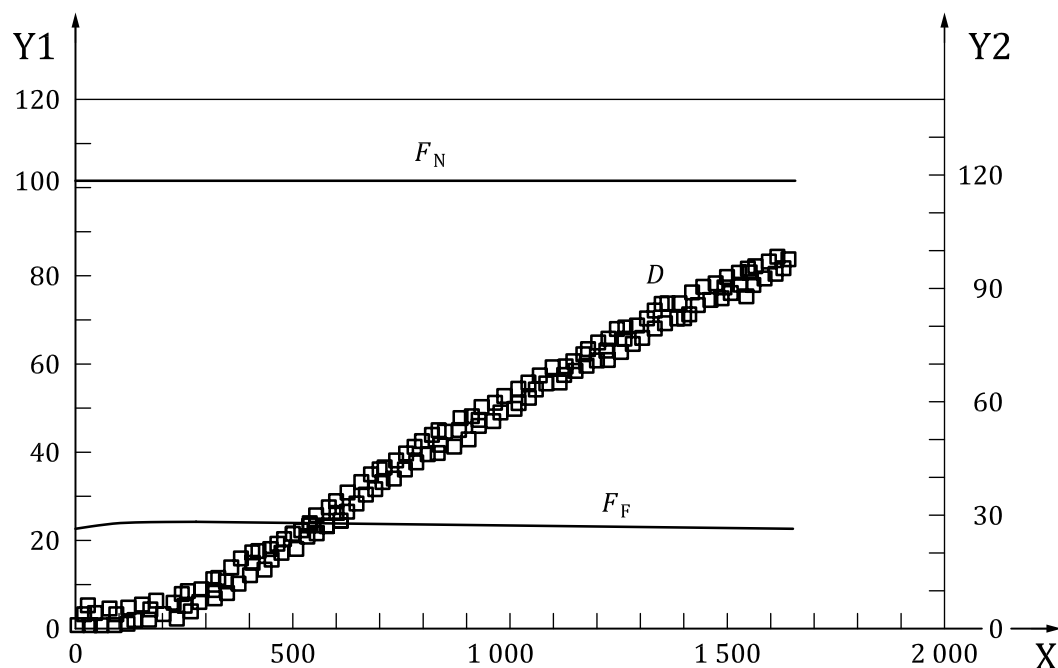

Key

- X time, t , in seconds (s)
- Y1 force, in newtons (N)
- Y2 flowrate, R , in millilitres per minute (ml min^{-1})
- F_N normal force, in newtons (N)
- F_F friction force, in newtons (N)
- D depth of wear, in micrometres (μm)

Figure 4 — On-line data acquisition on 9 % cobalt (Co) binder hardmetal

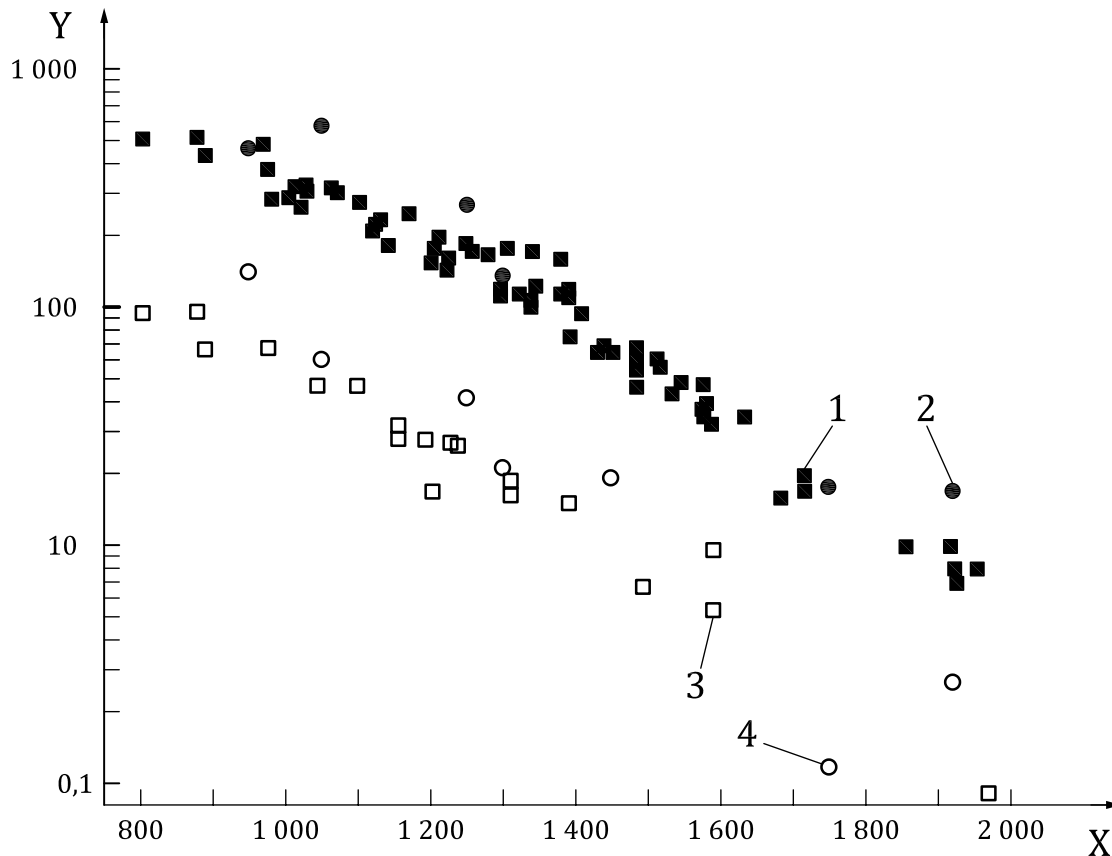

Key

- X hardness, HV30
- Y volume loss, in cubic millimetres (mm³)
- 1 variant 2 (ASTM B611) with alumina
- 2 variant 1 with alumina
- 3 variant 2 (ASTM B611) with silica (sand)
- 4 variant 1 with silica (sand)

Figure 5 — Comparative abrasion test result for tungsten carbide/cobalt WC/Co hardmetals

10 Uncertainty of measurement

There are no recent interlaboratory exercises on the measurement uncertainty of rotating-wheel abrasion tests for hardmetals. There is, nevertheless, some information available on the reproducibility and repeatability of these measurements available.

Figure 6 shows the results of ASTM B611 tests carried out in two different laboratories on WC/Co hardmetals. It should be noted that these measurements were carried out completely independently. The test systems were designed, constructed and managed differently, and the test materials were sourced separately. The common element was that ASTM B611 was followed in both laboratories. It can be seen that the overall agreement in results for the two different laboratories was good. There is some variation in results about the trend, but this is due to the variation of wear with changes in the microstructure of the hardmetals.

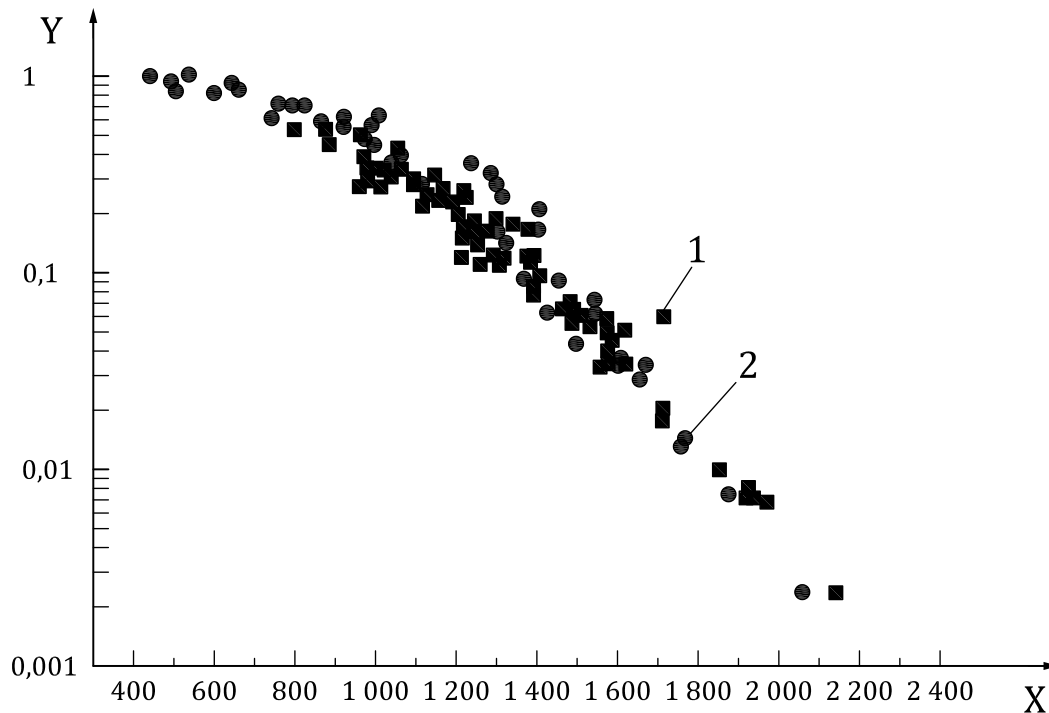

Key

- X hardness, HV30
- Y abrasion wear volume, in cubic millimetres (mm³)
- 1 laboratory 1
- 2 laboratory 2

Figure 6 — Comparison of ASTM B611 results between two laboratories

Analysis of a set of repeat ASTM B611 tests shows that the average difference between the two results for each material was 5 %, showing that the ASTM B611 test can have good repeatability when tests are carried out according to a well-defined test procedure.

It should be noted that the results of abrasion tests are dependent on many different parameters such as the abrasive material that is used, the abrasive shape, the size of abrasive, the abrasive loading, the load, the speed, the environment and the counterbody material. This means that, to get repeatable and reproducible results, it is extremely important to ensure that the test conditions are reproduced. It is particularly important to use abrasive that is very similar to achieve comparable results. Because the results of these tests are so dependent on the abrasive that is used, this often means that the abrasive should be obtained from the same source.

11 Test report

The test report shall include the following information:

- a) a reference to this document, i.e. ISO 28080:2021;
- b) the operator and the date;
- c) type of test system (instrumented, horizontal or vertical orientation of sample);
- d) schematic of test system;
- e) material tested;
- f) density of material tested;

- g) sample surface treatment;
- h) surface finish Ra of test piece, in micrometres (μm);
- i) abrasive material;
- j) abrasive size, in micrometres (μm);
- k) mass of abrasive used, in kilograms (kg);
- l) abrasive flowrate through contact, in kilograms per second (kg s^{-1});
- m) fluid flow or content of slurry, in cubic millimetres per second ($\text{mm}^3 \text{s}^{-1}$) or in percent (%), respectively;
- n) test duration in seconds (s);
- o) velocity of wheel periphery, in metres per second (m s^{-1});
- p) for a stepped test, graph of volume of wear with respect to mass of abrasive;
- q) volume of wear, in cubic millimetres (mm^3) quoted to nearest 0,1 mm^3 ;
- r) abrasion rate, quoted to nearest 0,1 $\text{mm}^3 \text{s}^{-1}$;
- s) illustration of the trends of depth of wear, friction force and normal force (see [9.3](#)) if an instrumented test system is used;
- t) details of any occurrence which might have affected the results (e.g. non-linear behaviour, incubation time, etc.);
- u) all options not specified in this document, or regarded as optional.

If a reference material is used, then the following parameters shall also be reported:

- v) reference material;
- w) wear rate of the reference material, in cubic millimetres per second ($\text{mm}^3 \text{s}^{-1}$);
- x) ratio of wear rates of test material to reference material.

Bibliography

- [1] ELLIS J., ARMSTRONG B.M. *Evaluation of Wear Resistant Materials for Use in Materials Handling Systems*, Report Number SL/CS/P/13/90/O, British Steel Technical, Swinden Laboratories
- [2] STEPHENSON A.N.J., HUTCHINGS I.M., Development of the dry sand/rubber wheel abrasion test, *Wear*, **195** (1996), pp. 232-240
- [3] GEE M.G., GANT A.J., BYRNE W.P. *An NPL Rotating Wheel Abrasion Test*, NPL Measurement Note, CMMT(MN) 30, November 1998
- [4] GRIGOROUDIS K., STEPHENSON D., Modelling low stress abrasive wear, *Wear*, **213** (1997), pp. 103-111
- [5] WIROJANUPATUMP S., SHIPWAY P.H., A direct comparison of wet and dry abrasion behaviour of mild steel, *Wear*, **233-235** (1999), pp. 655-665
- [6] HERR M., SAILER T., SOCKEL H.G., SCHULTE R., FELD H., PRAKASH L.J., Characterisation of wear properties of ultrafine-grained hardmetals using a special abrasive wheel test, *International Journal of Refractory Metals and Hard Materials*, Volume **19**, Issues 4-6, July-November 2001, pp. 371-379

[\(Continued from second cover\)](#)

<i>International Standard</i>	<i>Title</i>
ASTM G65 : 2021	Standard test method for measuring abrasion using the dry sand/rubber wheel apparatus
ASTM G105 : 2020	Standard test method for conducting wet sand/rubber wheel abrasion tests

For the purpose of deciding whether a particular requirement of this standard is complied with, the final value, observed or calculated, expressing the result of a test or analysis shall be rounded off in accordance with IS 2 : 2022 'Rules for rounding off numerical values (*second revision*)'. The number of significant places retained in the rounded off value should be the same as that of the specified value in this standard.

Bureau of Indian Standards

BIS is a statutory institution established under the *Bureau of Indian Standards Act, 2016* to promote harmonious development of the activities of standardization, marking and quality certification of goods and attending to connected matters in the country.

Copyright

BIS has the copyright of all its publications. No part of these publications may be reproduced in any form without the prior permission in writing of BIS. This does not preclude the free use, in the course of implementing the standard, of necessary details, such as symbols and sizes, type or grade designations. Enquiries relating to copyright be addressed to the Head (Publication & Sales), BIS.

Review of Indian Standards

Amendments are issued to standards as the need arises on the basis of comments. Standards are also reviewed periodically; a standard along with amendments is reaffirmed when such review indicates that no changes are needed; if the review indicates that changes are needed, it is taken up for revision. Users of Indian Standards should ascertain that they are in possession of the latest amendments or edition by referring to the website-www.bis.gov.in or www.standardsbis.in.

This Indian Standard has been developed from Doc No.: MTD 25 (21872).

Amendments Issued Since Publication

Amend No.	Date of Issue	Text Affected

BUREAU OF INDIAN STANDARDS

Headquarters:

Manak Bhavan, 9 Bahadur Shah Zafar Marg, New Delhi 110002

Telephones: 2323 0131, 2323 3375, 2323 9402

Website: www.bis.gov.in

Regional Offices:

	Telephones
Central : 601/A, Konnectus Tower -1, 6 th Floor, DMRC Building, Bhavbhuti Marg, New Delhi 110002	{ 2323 7617
Eastern : 8 th Floor, Plot No 7/7 & 7/8, CP Block, Sector V, Salt Lake, Kolkata, West Bengal 700091	{ 2367 0012 2320 9474
Northern : Plot No. 4-A, Sector 27-B, Madhya Marg, Chandigarh 160019	{ 265 9930
Southern : C.I.T. Campus, IV Cross Road, Taramani, Chennai 600113	{ 2254 1442 2254 1216
Western : Manakalya, 5 th Floor/MTNL CETTM, Technology Street, Hiranandani Gardens, Powai Mumbai 400076	{ 25700030 25702715

Branches : AHMEDABAD, BENGALURU, BHOPAL, BHUBANESHWAR, CHANDIGARH, CHENNAI, COIMBATORE, DEHRADUN, DELHI, FARIDABAD, GHAZIABAD, GUWAHATI, HARYANA (CHANDIGARH), HUBLI, HYDERABAD, JAIPUR, JAMMU, JAMSHEDPUR, KOCHI, KOLKATA, LUCKNOW, MADURAI, MUMBAI, NAGPUR, NOIDA, PARWANOO, PATNA, PUNE, RAIPUR, RAJKOT, SURAT, VIJAYAWADA.