औद्योगिक घटकों के लिए माइक्रो-फोकल
रेडियोग्राफी — अनुशंसित अभ्यास

Micro-focal Radiography for
Industrial Components —
Recommended Practices

ICS 91.100

© BIS 2024



भारतीय मानक ब्यूरो
BUREAU OF INDIAN STANDARDS
मानक भवन, 9 बहादुर शाह ज़फर मार्ग, नई दिल्ली - 110002
MANAK BHAVAN, 9 BAHADUR SHAH ZAFAR MARG
NEW DELHI - 110002
www.bis.gov.in www.standardsbis.in

September 2024

Price Group 5

FOREWORD

This Indian Standard was adopted by the Bureau of Indian Standards, after the draft finalized by the Non-Destructive Testing Sectional Committee had been approved by the Metallurgical Engineering Division Council.

X-Ray equipments having the focal spot size less than 100 μm are referred as microfocus system. Currently there are advanced micro-focus systems having focal spot size of even 5 μm . Micro-focus radiography systems have the capability to examine even the miniature details of an article by using the magnified X-ray images, which enhances the capability of flaw detection and the reliability. As there is no penumbra effect, the images obtained have very high resolution.

Currently when there is an advancement of technology, cost effectiveness and weight reduction are major factors. Accordingly the detection of finer defects and enhancement of reliability are prime factors for not only for strategic sectors but also for generic applications. These factors necessitates for microfocus radiography inspection and hence a need to have a standard.

This Indian Standard covers the recommended practice for micro-focal radiography of materials, components and assemblies. The practice outlined in this standard is intended to provide the basis for good working practices for producing high quality radiographs for inspection of welded joints and castings used in strategic sectors like Aerospace, Defence and Nuclear, etc, turbine blade inspection to detect fine cracks; inspection of printed circuit boards (PCB), inspection of tube to tube sheet weld of heat exchangers; inspection of ceramics and composites to detect micro-voids, etc. This standard deals with micro-focal x-ray systems, focal spot measuring techniques, magnification, image recording methods and image quality.

The composition of the Committee responsible for the formulation of this standard is given in [Annex A](#).

For the purpose of deciding whether a particular requirements of this standard is complied with, the final value, observed or calculated, expressing the result of a test or analysis shall be rounded off in accordance with IS 2 : 2022 'Rules for rounding off numerical value (*second revision*)'. The number of significant places retained in the rounded off value should be the same as that of the specified value in this standard.

Indian Standard

MICRO-FOCAL RADIOGRAPHY FOR INDUSTRIAL COMPONENTS — RECOMMENDED PRACTICES

1 SCOPE

This standard given below covers the recommended practice for micro-focal radiography of materials, components and assemblies. The practice outlined in this document is intended to provide the basis for good working practices for producing high quality radiographs. This standard deals with micro-focal x-ray systems, focal spot measuring techniques, magnification, image recording methods and image quality.

2 REFERENCES

The standard contains provisions, which through reference in this text, constitute provision of this standard. At the time of the publication, the edition indicated below was valid. All the standards are subject to revision, and parties to agreement based on this standard are encouraged to investigate the possibility applying the most recent edition of this standard.

<i>IS No.</i>	<i>Title</i>
IS 13805 : 2004	General standard for qualification and certification of non-destructive testing personnel — Specification (<i>first revision</i>)

3 PERSONAL QUALIFICATION

3.1 Personnel designated to carry out microfocal radiography shall be trained on the microfocal x-ray equipment with hands on training. Training will include troubleshooting and maintenance of the microfocal x-ray unit and proper handling procedures to prevent any unnecessary issues with being able to reproduce the desired results. They will be familiar with the operating instructions and shall have a good working knowledge of the equipment and its limitations.

3.2 Nondestructive testing (NDT) personnel shall be qualified and certified as per IS 13805 or any other nationally or internationally recognized NDT personnel qualifications practice or standards. Personnel who are performing radiography inspection shall have at least Level-I certification and at least Level-II for personnel who are performing interpretation of x-rays (IS 13805).

4 MICRO-FOCAL RADIOGRAPHY

4.1 In conventional radiography units, the size of the focal spot ranges from 1 mm to 5 mm. Hence to

keep geometric unsharpness (U_g) as low as possible, the film is placed in intimate contact with the object [(minimizing object to film distance (OFD)] and the source to object distance is increased. However, the source to object distance (SOD) cannot be increased beyond a limit, since this would make the exposure time impractical. An alternative method is to reduce the focal spot. X-ray equipment in which the size of the focal spot is between 0.1 mm to 1 mm is commonly referred to as minifocus unit while X-ray equipment in which the focal spot size is less than 0.1 mm or 100 micrometers is referred to as microfocus unit. This small focal spot is achieved by focusing the electron beam on to the target. Present day microfocus units have focal spots in the range of 5 micrometers to 15 micrometers.

4.2 The technique of radiography is based on the principles of differential absorption and shadow projection. Thus, one of the main parameters which determine the image quality and the detectability of features is the area from where the X-rays originate commonly known as the 'focal spot'. It can be observed from (*see* Fig.1), that while a point source of radiation produces a sharp image, a large source produces a diffused image with a large geometric unsharpness. This geometric unsharpness (U_g) primarily depends on the focal spot size as given by the relation.

$$U_g = \frac{f \times OFD}{SOD}$$

where

f = focal spot size;

OFD = the object to film distance; and

SOD = the source to object distance.

Once the focal spot size is reduced, a number of advantages can be identified. These include:

a) Projection magnification

The object need not be in contact with the film during exposure as in conventional radiography. Thus one can obtain enlarged primary radiographs with magnifications greater than 2X (*see* Fig. 1). Magnification reduces the number of features that is masked by the background image noise thus enhancing the detection sensitivity of micro-defects;

b) Improved radiographic contrast

In conventional radiography, scattered radiation especially generated from within the object reduces radiographic contrast. In microfocal radiography, since the object is placed away from the film, the amount of scattered radiation reaching the film is largely reduced. Thus, microfocal radiographs have better contrast compared to conventional radiographs; and

c) Possibility of object manipulation

Since the object and the film can be separated without sacrificing image definition, real time radiography of dynamic/temporally changing events is possible. Further the object can be rotated/translated within the radiation beam making stereo and microtomography possible. These techniques allow for better detection of planar defects and greater resolution of detail within the section thickness.

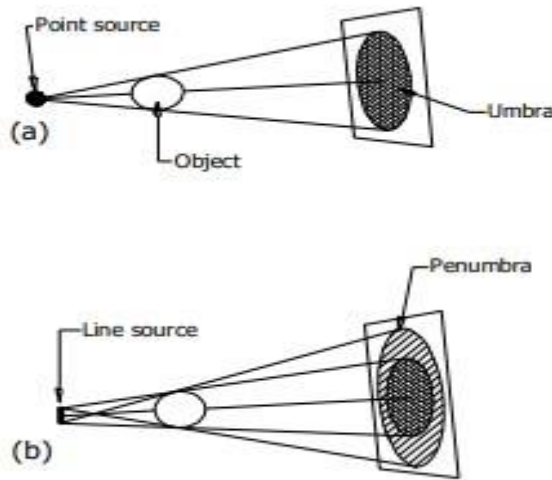

FIG. 1 IMAGE DUE TO POINT SOURCE OF RADIATION AND LINE SOURCE OF RADIATION

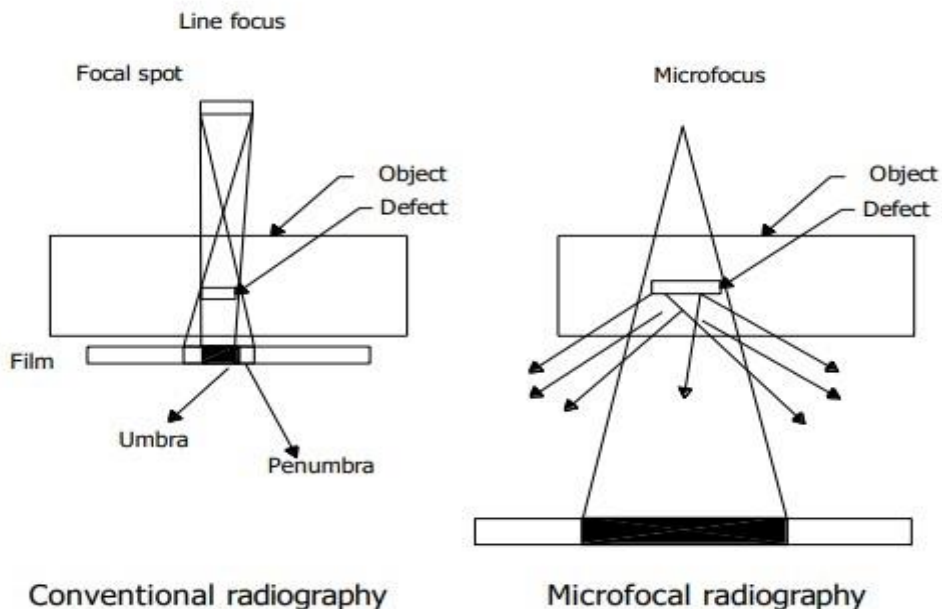

FIG. 2 MICROFOCAL SPOT MAKES IT POSSIBLE TO HAVE PROJECTIVE MAGNIFICATION AND HIGH CONTRAST RADIOGRAPHS DUE TO DECREASED SCATTER RADIATION

Projection magnification has its inherent disadvantages given below:

- a) Since the object is placed closed to the source, a smaller volume of the object is inspected at any one time as can be seen from (*see* Fig. 2). This means more number of exposures and more number of films; and
- b) Since the electrons are focused on to the target, the heat is concentrated in a very small and localized spot. Hence the target cannot be loaded to a great extent which limits the tube current.

5 PARAMETERS

5.1 Focal Spot in a Microfocus Unit

The X-ray focal spot is characterised by its size, shape and luminance profile. This is of special interest to both the manufacturer and the user. Determination of focal spot of microfocus units has been a challenge right from the beginning. Conventional method of focal spot measurement is the pinhole method. However, due to the difficulty in having pinholes of the order of 0.05 micrometers in high atomic number materials, this method is difficult to apply. However, by using appropriate image processing tools the focal spot size can be determined.

The following methods are used for measurement of focal spot size:

- a) Scanning method;
- b) Pinhole method;
- c) Slit camera method;
- d) Edge method;
- e) Focal spot size measurement of micro-focus tubes using platinum wires or lead sphere;
- f) Use of modulation transfer function in determination of focal spot dimensions; and
- g) Micro focus resolution chart.

5.2 Magnification

The primary advantage of having an extremely small focal spot is projective magnification. This means that the object need not be in contact with the film during exposure as in conventional radiography. Thus one can obtain enlarged primary radiographs with magnifications (M) greater than 2X.

The magnification factor is defined as the ratio of the source to imaging plane distance and source to object distance and is expressed mathematically as follows:

$$M = \frac{SFD}{(SFD - OFD)}$$

where



OFD = the object to film distance; and
SOD = the source to object distance.

Simple formula that relates the image blur (U_g) to the magnification (M) and the focal spot size (F) is as follows:

$$U_g = F (M - 1)$$

6 MICROFOCUS X-RAY SYSTEM

6.1 Micro-focal X-ray units use either sealed X-ray tubes or a demountable tube. Sealed x-ray tubes have vacuum system and panoramic or directional rod anode. Demountable X-ray tubes have rotating rod anode. This is due to considerations like the possibility of replacing the filaments and targets. A typical microfocus unit consists of:

- a) A X-ray tube head in the form of an O-ring sealed, containing an electron accelerator section, an electron optics section, and replaceable probe with the actual X-ray emitting element, the target;
- b) A high voltage unit capable of supplying a stable and ripple-free high voltage; and
- c) A microprocessor based control console for display of system parameters and provide operator interface to control the operation of the high voltage generator, electron optics and the vacuum equipment.

Fig. 3 shows the typical components in a microfocus unit. The electrons are accelerated by the electrical field between the cathode and the anode, which has a central hole to let the electrons through. The electron beam is focused on to the target by a set of electromagnetic lenses and deflection coils. This is the most critical part in a microfocus tube. The field strength of the lenses should be precisely adjusted with the velocity of the electrons for effectively focusing them onto a small spot on the target surface. After passing the deflection coils the electrons enter the probe. At the end of the probe is the target. This target can be a conical target, flat target or thin target. The conical target produces a radial panoramic beam while a thin the flat target produces a beam in the forward direction and a thick flat target produces a beam in the backward direction. Thus a variety of probes are possible each with different beam configuration. The probes can be of varying lengths depending on the requirement

ranging from about 10 mm to 400 mm and in some special cases upto 1 000 mm. The diameter of the probes can be as small as 8 mm. Probes can also be equipped with MuMetal shielding to overcome the effects of magnetic fields when examining tubes of magnetic material which are likely to be magnetized during the welding operation.

6.2 Detector System

Generally in conventional radiography the detector is normally a sheet of photographic film that on exposure to X- or gamma rays and subsequent development provide a negative image.

Similarly in micro focal radiography, fast, medium and slow films can be used for imaging. Apart from this, for real time imaging systems, image intensifiers, x-ray sensitive vidicon camera, and higher frame rate 25 fps [(frames per second) or higher] flat panels shall be used.

7 APPLICATION AREAS

The main areas of application of microfocal radiography can be classified as:

- a) Those where conventional radiography cannot be applied due to problems of access such as evaluation of tube to tube

sheet welds of steam generator, mode couplers, etc;

- b) Those where conventional radiography can be applied but cannot resolve the fine defects necessary to be detected example detection of microdefects such as voids, microcracks and inhomogenous distribution of material in ceramics and detection of defects in microelectronic components;
- c) For real time and computed tomography applications where microfocal radiography is an essential requirement due to higher detector unsharpness of real-time systems example online evaluation of automotive components;
- d) for inspection of integrated circuits and PCB's; and
- e) for inspection of tube to tube sheet weld inspection.

8 SAFETY

Microfocal radiography involves the use of hazardous ionizing radiations. Hence all necessary safety precautions with respect to location of unit in an appropriate shielded enclosure and also area and personnel monitoring as stipulated by atomic energy regulatory board (AERB) shall be followed.

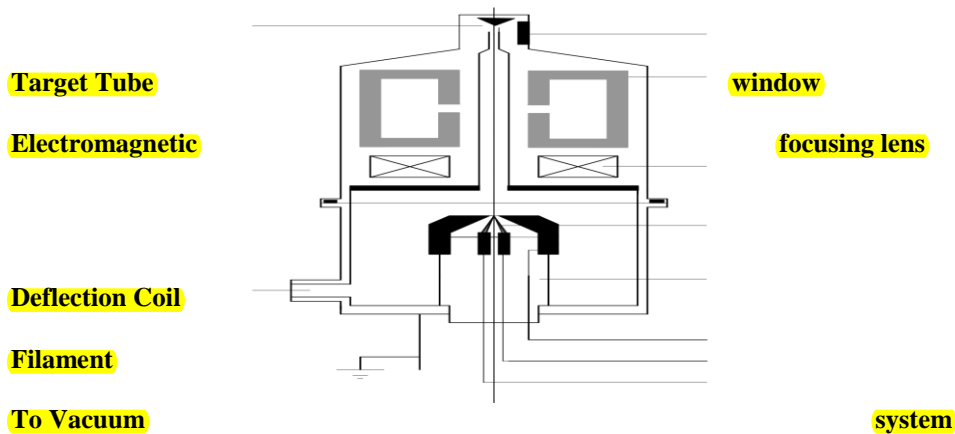

FIG. 3 TYPICAL COMPONENTS IN MICRO-FOCUS X-RAY UNIT



ANNEX A

(Foreword)

COMMITTEE COMPOSITION

Non-Destructive Testing Sectional Committee, MTD 21

<i>Organization</i>	<i>Representative (s)</i>
Indira Gandhi Centre for Atomic Research (IGCAR), Kalpakkam	DR B. VENKATRAMAN (Chairperson)
Arora Technologies Private Limited, Nerul, Navi Mumbai	SHRI MUKESH ARORA SHRI ALOK PANDEY (<i>Alternate I</i>) SHRI PUSHPALAXMI VANNIYAR (<i>Alternate II</i>)
Atomic Energy Regulatory Board (AERB), Mumbai	SHRI AMIT SEN SHRI ALOK PANDEY (<i>Alternate</i>)
Bhabha Atomic Research Centre, Mumbai	DR ARBINDA KUMAR DR PARITOSH NANEKAR (<i>Alternate</i>)
Bharat Heavy Electrical Limited, New Delhi	SHRI R. ARUL PRABHU SHRI SHYAMSUNDER REDDY A (<i>Alternate I</i>) SHRI RAKESH KUMAR MUNDA (<i>Alternate II</i>) SHRI B. K. SETHUPATHY (<i>Alternate III</i>)
BVG Nuclear Private Limited, Pune	DR VIVEK NAGESH YELGAONKAR DR TUSHAR GHATE (<i>Alternate</i>)
Centre for Design and Manufacture, Bhabha Atomic Research Centre, Mumbai	SHRI R. K. GUPTA SHRI LALIT MOHAN (<i>Alternate</i>)
CSIR - National Physical Laboratory, New Delhi	DR PREMSHANKAR K. DUBEY DR NAVEEN GARG (<i>Alternate</i>)
CSIR -National Metallurgical Laboratory, Jamshedpur	DR SARMISTHA PALIT SAGAR DR ASHISH KUMAR PANDA (<i>Alternate</i>)
Defence Metallurgical Research Laboratory, Ministry of Defence, Hyderabad	DR M. PHANI SURYA KIRAN SHRI A. MUKHOPADHYAY (<i>Alternate</i>)
Department of Space, Bengaluru	SHRI S. SARATCHANDRAN SHRI M. RUMUGAM (<i>Alternate</i>)
Department of Space, Indian Space Research Organisation, Satish Dhawan Space Centre, Sriharikota	DR B. MUNIRATHINAM SHRI P. V. S. KURMANATH (<i>Alternate</i>)
Directorate General of Quality Assurance, Ministry of Defence, New Delhi	SHRI ASHOK KUMAR SHRI M. K. SHRIVASTAV (<i>Alternate</i>)
Electrical Research and Development Association, Vadodara	DR G. S. GREWAL SHRI R. N. PATIL (<i>Alternate</i>)
Ferro Flux Limited, Ahmedabad	SHRI S. I. SANKLECHA SHRI MANDAR VINZE (<i>Alternate</i>)

<i>Organization</i>	<i>Representative (s)</i>
Gujarat State Fertilizers and Chemicals Limited, Vadodara	SHRI A. S. SIKDAR SHRI K. R. SHETH (<i>Alternate</i>)
Indian Institute of Technology, Roorkee	DR VIKRAM DABHADE
Indian Society for Non-Destructive Testing (ISNT), Chennai	SHRI DIWAKAR D. JOSHI DR KRISHNAN BALASUBRAMANIAM (<i>Alternate</i>)
Indira Gandhi Centre for Atomic Research, Kalpakkam	DR K. V. RAJKUMAR SHRIMATI M. MENAKA (<i>Alternate</i>)
Larsen and Toubro Limited, Mumbai	SHRI A. D. PARANJPE SHRI P. B. PATIL (<i>Alternate</i>)
M. N. Dastur and Company Private Limited, Kolkata	SHRI G. S. KULKARNI SHRI HIMANSHU GUPTA (<i>Alternate</i>)
Department for Promotion of Industry and Internal Trade, Ministry of Commerce and Industry, New Delhi	SHRI T. S. G. NARAYANNEN SHRI S. K. JAIN (<i>Alternate</i>)
National Test House, Kolkata	 SHRI SHER SINGH (<i>Alternate</i>)
NTPC Limited, New Delhi	SHRI D. D. N. VERMA
Nuclear Fuel Complex, Hyderabad	SHRI B. KAMALESH KUMAR SHRI SWARUP ACHARYA (<i>Alternate</i>)
Nuclear Power Corporation of India Limited (NPCIL), Mumbai	SHRI J. K. JAIN SHRI N. P. SRIVASTAVA (<i>Alternate</i>)
P-Met High-Tech Company Private Limited, Vadodara	SHRI HEMAL MEHTA SHRI P. K. PANCHAL (<i>Alternate</i>)
Pradeep Metal Treatment Chemicals Private Limited, Thane	SHRI D. J. VARDE SHRI KALESH A. NERUKAR (<i>Alternate</i>)
Research Designs and Standards Organization (RDSO), Lucknow	SHRI B. K. SAXENA SHRI B. L. JATAV (<i>Alternate</i>)
Satyakiran Engineers Private limited, New Delhi	SHRIMATI NAVITA GUPTA SHRI DINESH GUPTA (<i>Alternate</i>)
Tata Motors Limited, Pune	SHRI P. M. KULKARNI SHRI AKSHAY KULKARNI (<i>Alternate I</i>) SHRI HEMANT MORE (<i>Alternate II</i>)
Tata Steel Limited, Kolkata	SHRI S. BALAMURUGAN SHRI R. SHUMUGA SUNDARAM (<i>Alternate</i>)
Technofour Electronics Private Limited, Pune	SHRI PRAVIN DHOLE SHRI BHARAT S. BIRADAR (<i>Alternate I</i>) SHRI PRADEEP J. LAD (<i>Alternate II</i>)

<i>Organization</i>	<i>Representative (s)</i>
BIS Directorate General	SHRI SANJIV MAINI, SCIENTIST 'F'/SENIOR DIRECTOR AND HEAD (METALLURGICAL ENGINEERING) [REPRESENTING DIRECTOR GENERAL (<i>Ex-officio</i>)]

Member Secretary
SHRI KUNAL KUMAR
SCIENTIST 'E'/DIRECTOR
(METALLURGICAL ENGINEERING), BIS

Bureau of Indian Standards

BIS is a statutory institution established under the *Bureau of Indian Standards Act, 2016* to promote harmonious development of the activities of standardization, marking and quality certification of goods and attending to connected matters in the country.

Copyright

BIS has the copyright of all its publications. No part of these publications may be reproduced in any form without the prior permission in writing of BIS. This does not preclude the free use, in the course of implementing the standard, of necessary details, such as symbols and sizes, type or grade designations. Enquiries relating to copyright be addressed to the Head (Publication & Sales), BIS.

Review of Indian Standards

Amendments are issued to standards as the need arises on the basis of comments. Standards are also reviewed periodically; a standard along with amendments is reaffirmed when such review indicates that no changes are needed; if the review indicates that changes are needed, it is taken up for revision. Users of Indian Standards should ascertain that they are in possession of the latest amendments or edition by referring to the website-www.bis.gov.in or www.standardsbis.in.

This Indian Standard has been developed from Doc No.: MTD 21 (21512).

Amendments Issued Since Publication

Amend No.	Date of Issue	Text Affected

BUREAU OF INDIAN STANDARDS

Headquarters:

Manak Bhavan, 9 Bahadur Shah Zafar Marg, New Delhi 110002

Telephones: 2323 0131, 2323 3375, 2323 9402

Website: www.bis.gov.in

Regional Offices:

Central : 601/A, Konnectus Tower -1, 6th Floor,
DMRC Building, Bhavbhuti Marg, New
Delhi 110002

Telephones

{ 2323 7617

Eastern : 8th Floor, Plot No 7/7 & 7/8, CP Block, Sector V,
Salt Lake, Kolkata, West Bengal 700091

{ 2367 0012
2320 9474

Northern : Plot No. 4-A, Sector 27-B, Madhya Marg,
Chandigarh 160019

{ 265 9930

Southern : C.I.T. Campus, IV Cross Road, Taramani, Chennai 600113

{ 2254 1442
2254 1216

Western : Manakalya, 5th Floor/MTNL CETTM, Technology Street, Hiranandani Gardens, Powai
Mumbai 400076

{ 25700030
25702715

Branches : AHMEDABAD, BENGALURU, BHOPAL, BHUBANESHWAR, CHANDIGARH, CHENNAI, COIMBATORE, DEHRADUN, DELHI, FARIDABAD, GHAZIABAD, GUWAHATI, HARYANA (CHANDIGARH), HUBLI, HYDERABAD, JAIPUR, JAMMU, JAMSHEDPUR, KOCHI, KOLKATA, LUCKNOW, MADURAI, MUMBAI, NAGPUR, NOIDA, PARWANOO, PATNA, PUNE, RAIPUR, RAJKOT, SURAT, VIJAYAWADA.