

सहायक उत्पाद — व्यक्तियों के स्थानांतरण के
लिए उत्तोलक — अपेक्षाएँ और परीक्षण
पद्धतियाँ



Assistive Products — Hoists for
the Transfer of Persons —
Requirements and Test Methods

ICS 11.180.10

© BIS 2024

© ISO 2021



भारतीय मानक ब्यूरो
BUREAU OF INDIAN STANDARDS
मानक भवन, 9 बहादुर शाह ज़फर मार्ग, नई दिल्ली - 110002
MANAK BHAVAN, 9 BAHADUR SHAH ZAFAR MARG
NEW DELHI - 110002

www.bis.gov.in

www.standardsbis.in

NATIONAL FOREWORD

This Indian Standard which is an identical adoption of ISO 10535 : 2021 'Assistive products — Hoists for the transfer of persons — Requirements and test methods' issued by the International Organization for Standardization (ISO) was adopted by the Bureau of Indian Standards on the recommendation of the Artificial Limbs, Rehabilitation Appliances and Equipment for the Person with Disability Sectional Committee and approval of the Medical Equipment and Hospital Planning Division Council.

The text of the ISO standard has been approved as suitable for publication as an Indian Standard without deviations. Certain conventions are, however, not identical to those used in Indian Standards. Attention is particularly drawn to the following:

- a) Wherever the words 'International Standard' appears referring to this standard, they should be read as 'Indian Standard'; and
- b) Comma (,) has been used as a decimal marker while in Indian Standard, the current practice is to use a point (.) as the decimal marker.

In this adopted standard, reference appears to certain International Standards for which Indian Standards also exist. The corresponding Indian Standards which are to be substituted in their respective places are listed below along with their degree of equivalence for the editions indicated:

<i>International Standard</i>	<i>Corresponding Indian Standard</i>	<i>Degree of Equivalence</i>
ISO 3758 Textiles — Care labelling code using symbols	IS 14452 : 2023/ISO 3758 : 2012 Textiles — Care labelling code using symbols (<i>second revision</i>)	Identical
ISO 9999 Technical aids for persons with disabilities — Classification and terminology	IS 18560 : 2024/ISO 9999 : 2022 Assistive Products — Classification and terminology	Identical
ISO 10993-1 Biological evaluation of medical devices — Part 1: Evaluation and testing	IS 17932 (Part 1) : 2023 Biological evaluation of medical devices: Part 1 Evaluation and testing within a risk management process	Modified
ISO 14253-1 Geometrical Product Specifications (GPS) — Inspection by measurement of work pieces and measuring equipment — Part 1: Decision rules for proving conformance or non-conformance with specifications	IS 15371 (Part 1) : 2023/ISO 14253-1 : 2017 Geometrical product specifications (GPS) — Inspection by measurement of workpieces and measuring equipment: Part 1 Decision rules for verifying conformity or nonconformity with specification (<i>first revision</i>)	Identical
ISO 14971 Medical devices — Application of risk management to medical devices	IS/ISO 14971 : 2019 Medical devices — Application of risk management to medical devices (<i>first revision</i>)	Identical

<i>International Standard</i>	<i>Corresponding Indian Standard</i>	<i>Degree of Equivalence</i>
EN 853 Rubber hoses and hose assemblies — Wire braid reinforced hydraulic type — Specification	IS 18135 : 2023/ISO 18752 : 2022 Rubber hoses and hose assemblies — Wire or textile reinforced single pressure types for hydraulic applications — Specification	Identical
EN 1021-1 Furniture — Assessment of the ignitability of upholstered furniture — Part 1: Ignition source: Smouldering cigarette	IS 12467 (Part 1) : 2006 Textiles — Assessment of the ignitability of upholstered furniture: Part 1 Ignition source: smouldering cigarette (<i>first revision</i>)	Not Equivalent
EN 1021-2 Furniture — Assessment of the ignitability of upholstered furniture — Part 2: Ignition source: Match flame equivalent	IS 12467 (Part 2) : 2006 Textiles — Assessment of the ignitability of upholstered furniture: Part 2 Ignition source match flame equivalent (<i>first revision</i>)	Not Equivalent 
IEC 60529 Degrees of protection provided by enclosures (IP Code)	IS/IEC 60529 : 2001 Degrees of protection provided by enclosures (IP Code)	Identical
IEC 60601-1 Medical electrical equipment — Part 1: General requirements for basic safety and essential performance	IS 13450 (Part 1) : 2024 Medical electrical equipment: Part 1 General Requirements for Basic Safety and Essential Performance (IEC 60601-1: 2020, MOD) (<i>third revision</i>)	Modified
IEC 60601-1-2 Medical electrical equipment — Part 1- 2: General requirements for basic safety — Collateral Standard: Electromagnetic disturbances — Requirements and tests	IS 13450 (Part 1/Sec 2) : 2024 Medical electrical equipment: Part 1 General requirements for basic safety and essential performance, Section 2 electromagnetic disturbances — Requirements and tests (IEC 60601-1- 2: 2020, MOD) (<i>second revision</i>)	Modified
IEC 61000-3-2 Electromagnetic compatibility (EMC) — Part 3- 2: Limits — Limits for harmonic current emissions (equipment input current ≤ 16 A per phase)	IS 14700 (Part 3/Sec 2) : 2020/ IEC 61000-3-2 : 2018 Electromagnetic compatibility (EMC): Part 3 Limits, Section 2 Limits for harmonic current emissions (equipment input current ≤ 16 A per phase) (<i>third revision</i>)	Identical
IEC 61000-3-3 Electromagnetic compatibility (EMC) — Part 3- 3: Limits — Limitation of voltage changes, voltage fluctuations and flicker in public low voltage supply systems, for equipment with rated current ≤ 16 A per phase and not subject to conditional connection	IS 14700 (Part 3/Sec 3) : 2018/ IEC 61000-3-3 : 2013 Electromagnetic compatibility (EMC): Part 3 Limits, Section 3 Limitation of voltage changes, voltage fluctuations and flicker in public low-voltage supply system, for equipment with rated current ≤ 16 A per phase and not subjected to conditional connection (<i>second revision</i>)	Identical

<i>International Standard</i>	<i>Corresponding Indian Standard</i>	<i>Degree of Equivalence</i>
IEC 61000-4-3 Electromagnetic compatibility (EMC) — Part 4-3 : Testing and measurement techniques — Radiated, radio-frequency, electromagnetic field immunity test	IS 14700 (Part 4/Sec 3) : 2023/IEC 61000-4-3 : 2020 Electromagnetic compatibility (EMC): Part 4 Testing and measurement techniques, Section 3 Radiated, radio-frequency electromagnetic field immunity test (second revision)	Identical
IEC 61672-1 Electroacoustics — Sound level meters — Part 1: Specifications	IS 15575 (Part 1): 2016/IEC 61672-1: 2013 Electroacoustics — Sound level meters: Part 1 Specifications (<i>first revision</i>)	Identical

The Committee responsible for the preparation of this standard has reviewed the provisions of following mentioned International Standards and has decided that they are acceptable for use in conjunction with this standard:

<i>International Standard/Other Standard</i>	<i>Title</i>
ISO 3746	Acoustics — Determination of sound power levels and sound energy levels of noise sources using sound pressure — Survey method using an enveloping measurement surface over a reflecting plane
EN 614-1	Safety of machinery — Ergonomic design principles — Part 1: Terminology and general principles
EN 980	Graphical symbols for use in the labeling of medical devices
EN 12182 : 1999	Technical aids for disabled persons — General requirements and test methods
EN 13480-3	Metallic industrial piping — Part 3: Design and calculation

In this text references have been made to International Standards which have been revised as follows:

- a) ISO 9999 : 2002, Technical aids for persons with disabilities — Classification and terminology has been revised to ISO 9999 : 2022 Assistive products — Classification and terminology;
- b) IEC 60601-1: 2005: The latest version IEC 60601-1 : 2005 + Amd 1 : 2012 + Amd 2 : 2020 CSV has been adopted as IS 13450 (Part 1): 2024 with modifications;
- c) IEC 60601-1-2: 2005: The latest version IEC 60601-1-2:2014+Amd 1:2020 has been adopted as 13450 (Part 1/ Sec 2): 2024 with modifications; and
- d) EN 13480-3: 2017 is the latest version.

This standard also makes a reference to the BIS Certification Marking of the product, details of which is given in [National Annex A](#).

In reporting the result of a test or analysis made in accordance with this standard, if the final value, observed or calculated, expressing the result of a test or analysis, shall be rounded off in accordance with IS 2 : 2022 'Rules for rounding off numerical values (*second revision*)'.

Contents

Page

Introduction	v
1 Scope	1
2 Normative references	1
3 Terms and definitions.....	2
4 General requirements and test methods.....	7
4.1 General requirements.....	7
4.2 General test methods	7
4.3 Safety requirements	12
4.4 Requirements for body-support units	17
4.5 Central suspension point.....	17
4.6 Spreader bar	17
4.7 Performance	17
4.8 Rate (velocity) of lifting and lowering.....	18
4.9 Operating forces/torques	18
4.10 Durability	19
4.11 Hydraulic components	20
4.12 Pneumatic components	21
4.13 Information supplied by the manufacturer	22
5 Mobile hoists — Specific requirements and test methods.....	28
5.1 General requirements.....	28
5.2 Static strength.....	28
5.3 Static stability.....	29
5.4 Immobilizing device (brakes).....	29
5.5 Moving forces.....	30
5.6 Instructions for use	31
6 Standing and/or raising hoists — Specific requirements and test methods.....	32
6.1 General requirements.....	32
6.2 Static strength.....	32
6.3 Static stability.....	32
6.4 Immobilizing device (brakes).....	33
6.5 Moving forces.....	34
6.6 Durability	34
6.7 Instructions for use	35
7 Stationary hoists — Specific requirements and test methods	35
7.1 General requirements.....	35
7.2 Specific safety requirements.....	35
7.3 Static strength (free-standing stationary hoists only)	36
7.4 Static stability (free-standing stationary hoists only).....	36
7.5 Static strength for all other stationary hoists	37
7.6 Instructions for use	38
8 Non-rigid body-support units — Specific requirements and test methods.....	38
8.1 General requirements.....	38
8.2 Requirements for material and seams of the non-rigid body-support unit.....	38
8.3 Test methods for non-rigid body-support unit	38
8.4 Information supplied by the manufacturer	38
9 Rigid body-support units — Specific requirements and test methods.....	39

9.1	General requirements	39
9.2	Requirements for backrest.....	39
9.3	Requirements and test methods for durability	39
9.4	Information supplied by the manufacturer.....	40
10	Bathtub hoists — Specific requirements and test methods.....	41
10.1	General requirements	41
10.2	General test methods	41
10.3	Safety requirements.....	42
10.4	Body-support units	42
10.5	Spreader bar	42
10.6	Performance	42
10.7	Rate (velocity) of lifting and lowering	42
10.8	Operating forces	43
10.9	Durability.....	43
10.10	Static strength and stability.....	43
10.11	Hydraulic components	44
10.12	Pneumatic components.....	44
10.13	Specific safety requirements	44
10.14	Non-rigid body-support units	44
10.15	Rigid body-support units — Requirements.....	44
10.16	Information supplied by the manufacturer.....	45
Annex A	(informative) Structure of ISO 10535.....	46
Annex B	(informative) Periodic inspection	47
Annex B	(informative) Periodic inspection	48
National Annex A	49

Introduction

It appears from studies that the nursing and caring profession involves many physically burdening factors in the caring for and nursing of disabled persons. A hoist offers a safe means of supportive lifting and moving, either assisted or independently.

Indian Standard

HOISTS FOR THE TRANSFER OF DISABLED PERSONS — REQUIREMENTS AND TEST METHODS

1 Scope

This International Standard specifies requirements and test methods only for hoists and body-support units intended for the transfer of disabled persons as classified in ISO 9999:2002:

- 12 36 03 Mobile hoists with sling seats
- 12 36 04 Standing mobile hoists
- 12 36 06 Mobile hoists with solid seats
- 12 36 09 Hoist trolleys
- 12 36 12 Stationary hoists fixed to the wall/walls, floor and/or ceiling
- 12 36 15 Stationary hoists fixed to, mounted in or on another product
- 12 36 18 Stationary free-standing hoists
- 12 36 21 Body-support units for hoists

This International Standard does not apply to devices that transport persons between two levels (floors) of a building.

It does not include methods for the determination of ageing or corrosion of such hoists and units.

The requirements of this International Standard are formulated with regard to the needs of both the disabled persons being hoisted and the attendant using the hoist.

2 Normative references

The following referenced documents are indispensable for the application of this document. For dated references, only the edition cited applies. For undated references, the latest edition of the referenced document (including any amendments) applies.

ISO 3746, *Acoustics — Determination of sound power levels and sound energy levels of noise sources using sound pressure — Survey method using an enveloping measurement surface over a reflecting plane*

ISO 3758, *Textiles — Care labelling code using symbols*

ISO 9999:2002, *Technical aids for persons with disabilities — Classification and terminology*

ISO 10993-1, *Biological evaluation of medical devices — Part 1: Evaluation and testing*

ISO 14253-1, *Geometrical Product Specifications (GPS) — Inspection by measurement of workpieces and measuring equipment — Part 1: Decision rules for proving conformance or non-conformance with specifications*

ISO 14971, *Medical devices — Application of risk management to medical devices*

EN 614-1, *Safety of machinery — Ergonomic design principles — Part 1: Terminology and general principles*

EN 853, *Rubber hoses and hose assemblies — Wire braid reinforced hydraulic type — Specification*

EN 854, *Rubber hoses and hose assemblies — Textile reinforced hydraulic type — Specification*

EN 980, *Graphical symbols for use in the labelling of medical devices*

EN 1021-1, *Furniture — Assessment of the ignitability of upholstered furniture — Part 1: Ignition source: Smouldering cigarette*

EN 1021-2, *Furniture — Assessment of the ignitability of upholstered furniture — Part 2: Ignition source: Match flame equivalent*

EN 12182:1999, *Technical aids for disabled persons — General requirements and test methods*

EN 13480-3:2002, *Metallic industrial piping — Part 3: Design and calculation*

IEC 60529, *Degrees of protection provided by enclosures (IP Code)*

IEC 60601-1:2006, *Medical electrical equipment — Part 1: General requirements for basic safety and essential performance*

IEC 60601-1-2:2005, *Medical electrical equipment — Part 1-2: General requirements for safety — Collateral standard: Electromagnetic compatibility — Requirements and tests*

IEC 61000-3-2, *Electromagnetic compatibility (EMC) — Part 3-2: Limits — Limits for harmonic current emissions (equipment input current ≤ 16 A per phase)*

IEC 61000-3-3 am1, *Electromagnetic compatibility (EMC) — Part 3: Limits — Section 3: Limitation of voltage fluctuations and flicker in low-voltage supply systems for equipment with rated current ≤ 16 A*

IEC 61000-4-3, *Electromagnetic compatibility (EMC) — Part 4-3: Testing and measurement techniques — Radiated, radio-frequency electromagnetic field immunity test*

IEC 61672-1, *Electroacoustics — Sound level meters — Part 1: Specifications*

3 Terms and definitions

For the purposes of this document, the following terms and definitions apply.

3.1

adverse condition

condition in which failure is most likely to occur

3.2

attendant

person who operates the hoist if not the lifted person

3.3

backrest

part of the body-support unit that supports the back of the person being lifted, transferred or moved along with the associated attachment structure

EXAMPLE A body-support unit can be a sling, seat or stretcher.

3.4

backwards

180° to the forwards direction of travel

3.5

bath tub hoist

piece of equipment that is specifically designed to be used in or adjacent to a bathtub and with which a disabled person is lifted, transferred or moved

3.6

body-support unit

part of the hoist that supports the person being lifted, transferred or moved along with its associated attachment structure

EXAMPLE A body-support unit can be a sling, seat or stretcher.

3.7

ceiling hoist

overhead mounted hoist system fixed to the ceiling or wall(s), including the tracking system

3.8

central suspension point

CSP

reference point on the hoist to be used for measurements

NOTE This point may be a connecting point.

3.9

connecting point(s)

part(s) to which the body-support unit attaches

3.10

control devices

part or parts of the hoist which operate the lifting and lowering mechanisms of the CSP as well as other functions

EXAMPLE A function can be the leg opening of the mobile base.

3.11

end limiting device

device that stops any movement at a predetermined end position

3.12

flexible device

component along with any associated joining components that functions as a lifting device

EXAMPLE A flexible device can be a chain, tape or rope.

3.13

footrest

part of the body-support unit that supports the feet

3.14

forwards

intended direction of travel, as indicated by the manufacturer in the instructions for use

3.15

free-standing stationary hoist

equipment for transferring by lifting and moving a disabled person in an area limited by the system with the hoist free-standing on the floor

3.16
hoisting range

vertical difference between the maximum and minimum heights of the CSP

See Figure 1.

3.17
hoisting reach

unimpeded horizontal distance between the structure and a vertical line through the CSP at a given height within the hoisting range

See Figure 1 (b, c).

3.18
hold to run control device

control device(s) which initiate and maintain operation of the hoist elements only as long as the manual control is actuated and where the manual control automatically returns to the 'Stop' or 'Off' position when released

3.19
legrest

part of the body-support unit that supports the legs

3.20
lifted person

person who is transferred by the hoist

3.21
lifting cycle

raising and lowering of the lifting machinery for the same distance in both directions

3.22
lifting device

means of lifting and lowering the body-support unit

3.23
lifting machinery

device that performs the lifting function

EXAMPLE The lifting machinery can be a hydraulic, mechanical or electrical apparatus.

3.24
locking gate

device that ensures a hoist cannot move from one track to another unless both tracks are in the correct position

3.25
locking system

means by which the rigid body-support unit is secured to the hoist

3.26
maximum load

greatest permissible load, excluding the body-support unit, that can be applied to the hoist

3.27
mobile hoist

piece of equipment, fitted with a device or devices (e.g. wheels) that are freely movable and propellable along the floor, and with which a disabled person is lifted, transferred or moved independent of a fixed installation or other allied device

3.28

multi-purpose hoist

piece of equipment that can be assembled, possibly with the use of different parts, to provide a variety of operations

3.29

non-rigid body-support unit

device that is manufactured from flexible materials and which adapts to the body shape, with the associated connecting means for attaching to the lifting device of the hoist

3.30

rigid body-support unit

preformed seat or recumbent device, manufactured from rigid materials (if necessary padded), or flexible materials encased by a frame, with connecting means for attaching to the lifting device of the hoist

3.31

single fault condition

condition in which a single means for reducing the risk resulting from a hazard is defective or a single abnormal condition is present

3.32

sitting part

part of the body-support unit that is intended for sitting on

3.33

spreader bar

rigid construction with more than one connection point, on to which the body-support unit is attached

3.34

standing and/or raising hoist

device to assist the lifting, transferring and moving of a disabled person where some of the mass of the disabled person is supported by some means of footrest

3.35

stationary hoist

piece of equipment, with which a person is lifted, transferred or moved within a pre-defined area and which is fixed to a wall, ceiling or floor or is mounted or placed in or on other allied devices, or is free-standing

3.36

turning diameter

diameter of the narrowest circle encompassing the extreme points of the hoist, when it is turned 360° without being reversed

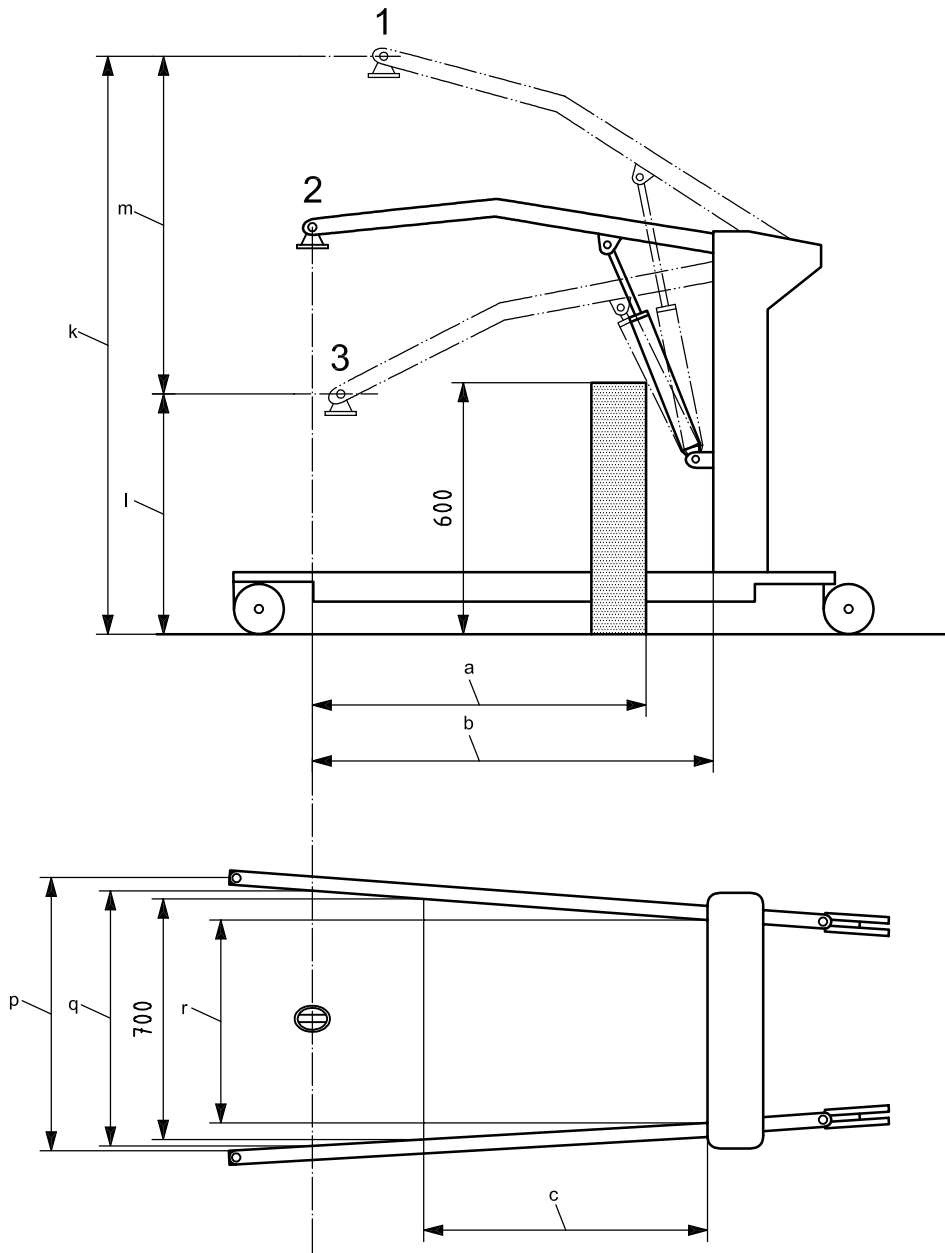

Key

- 1 highest position
- 2 maximum reach position
- 3 lowest position
- a Maximum reach at 600 mm (reference height).
- b Maximum reach from base.
- c Reach from base with legs spread to 700 mm.
- k Maximum height of CSP.
- l Minimum height of CSP.
- m Hoisting range.
- p Maximum internal width.
- q Internal width at maximum reach.
- r Minimum internal width.

NOTE Example, schematic presentation only.

Figure 1 — Key dimensions of mobile hoist

4 General requirements and test methods

4.1 General requirements

4.1.1 Risk analysis

The relevant clauses of ISO 14971 regarding risk analysis apply.

4.1.2 Ergonomic factors

Grips, handles and pedals shall suit the functional anatomy of the user, according to the intended use and meet with the following requirements:

- a) the distance between any handle (part intended to be grabbed) requiring an operating force of more than 10 N and any construction part of the hoist shall not be less than 35 mm;
- b) the distance between any upper surface of a pedal (in its operating position) and any other part of the hoist shall have a vertical toe clearance of not less than 75 mm;
- c) the diameter of any operating handles and/or knobs requiring an operating force of more than 10 N shall be between 19 mm and 43 mm;
- d) for hoists operated from a standing position, pedals shall be placed not more than 300 mm above the surface of the floor;
- e) for hoists operated from a standing position, hand operated controls shall be placed at a height of 800 mm to 1 200 mm above the floor;
- f) handles for pushing and/or pulling shall be placed at a minimum height of 900 mm.

NOTE Operating controls used by the lifted person may require other positions.

For further information on this subject see EN 614-1.

4.1.3 Noise

The maximum A-weighted sound power level of the hoist shall be measured in accordance with ISO 3746 during a transfer using the maximum load. This measurement shall also be undertaken with the hoist in an unloaded situation.

The results of these measurements shall be stated in the instructions for use.

4.2 General test methods

4.2.1 Test conditions

The hoist shall be tested in the as-delivered state (to the customer). However, if the hoist is of a multi-purpose design that can be assembled in different formats, it shall be assembled according to the instructions supplied by the manufacturer. If the hoist is intended to be used in different combinations, then all combinations shall be tested in the most adverse condition.

The tests shall be carried out under normal indoor conditions. All tests shall be carried out in the order stated and on one and the same sample hoist.

If the hoist is of a multi-purpose design that incorporates a standing and/or raising function, then the durability tests of Clause 5 only shall apply, however the requirements of Clause 5 and Clause 6 shall apply with regard to stability, static strength and push/pulling forces.

The test report referred to in 4.2.4 shall be placed in the manufacturer's technical file.

4.2.2 Test equipment

- 4.2.2.1 Test surface, rigid, flat, inclinable and with stops preventing the hoist from sliding but not tilting.
- 4.2.2.2 Stops no smaller than half of the wheel diameter and no greater than the wheel diameter.
- 4.2.2.3 Loads suitable for the loading of hoists and body-support units, e.g. cylindrical load(s), made of steel with rounded edges, (not less than R25) and with diameter 350 mm. For the testing of non-rigid body-support units the load can be made to represent the proposed body to be lifted.
- 4.2.2.4 Equipment capable of simulating use in practice (e.g., test fingers).
- 4.2.2.5 Equipment for applying loads, with negligible dynamic factor.
- 4.2.2.6 Sound level meter in accordance with IEC 61672-1.
- 4.2.2.7 Equipment for measuring pressure of water, oil and air.
- 4.2.2.8 Device for applying loads to standing and/or raising hoists (see Figure 2). The centre of gravity of the load shall be positioned as indicated and the centre of gravity shall be able to move as demonstrated by the joints.
- 4.2.2.9 Device for applying loads to rigid body support units [see Figures 3, 4 a) and 4 b].

4.2.3 Permissible errors of test equipment

The following maximum permissible error(s) of test equipment apply:

— pressures		$\pm 5 \%$
— forces/loads		$\pm 5 \%$
— velocities		$\pm 5 \%$
— angles		$\pm 0,25^\circ$
— dimensions	$\leq 100 \text{ mm}$	$\pm 0,5 \text{ mm}$
— dimensions	$> 100 \text{ mm}$	$\pm 0,5 \%$
— time		$\pm 0,1 \text{ s}$

For proving conformance or non-conformance with this specification, the procedures in accordance with ISO 14253-1 shall apply.

4.2.4 Test report

The test report shall include at least the following information:

- a reference to this International Standard, i.e. ISO 10535:2006;
- a description of the product, including type, designation and serial number;
- name and address of the manufacturer;
- a photograph of the hoist equipment as presented during test;
- the name and address of the testing laboratory;

- f) the stability values to the nearest $0,5^\circ$ rounded down;
- g) result of tests including record of maintenance, if any;
- h) any deviations from the standardized test procedure;
- i) date of test;
- j) test conditions regarding humidity and temperature.

Dimensions in millimetres

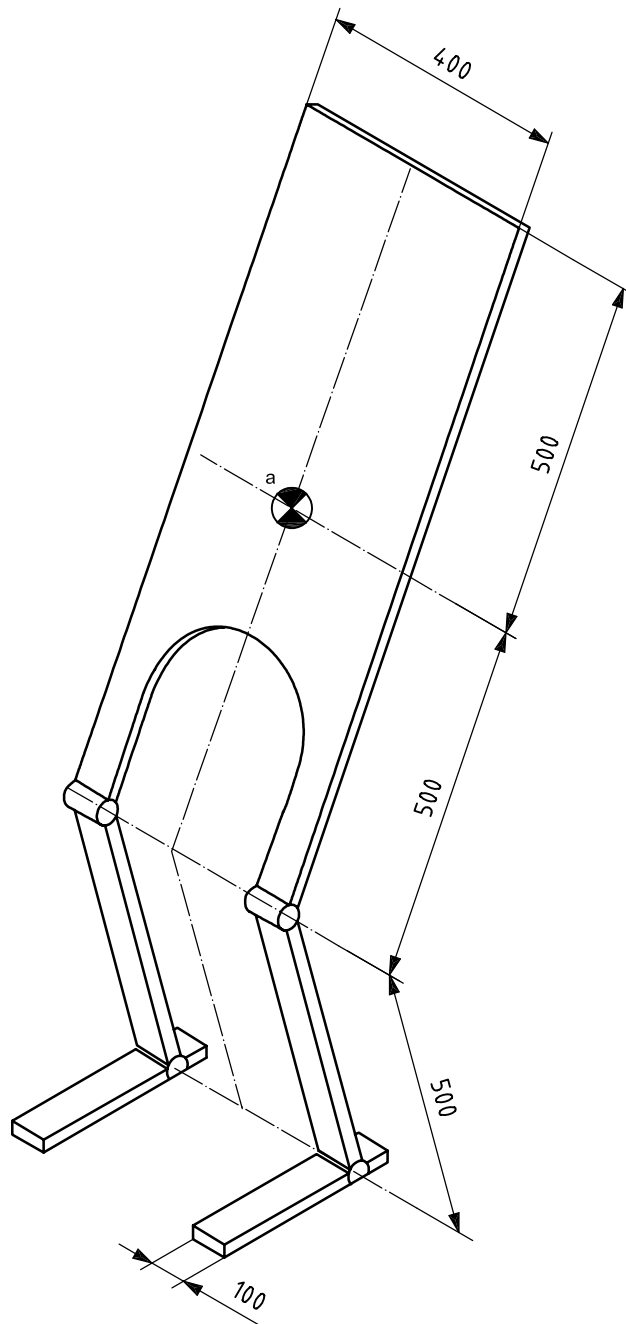

^a Centre of gravity.

Figure 2 — Test dummy for standing and/or raising hoists

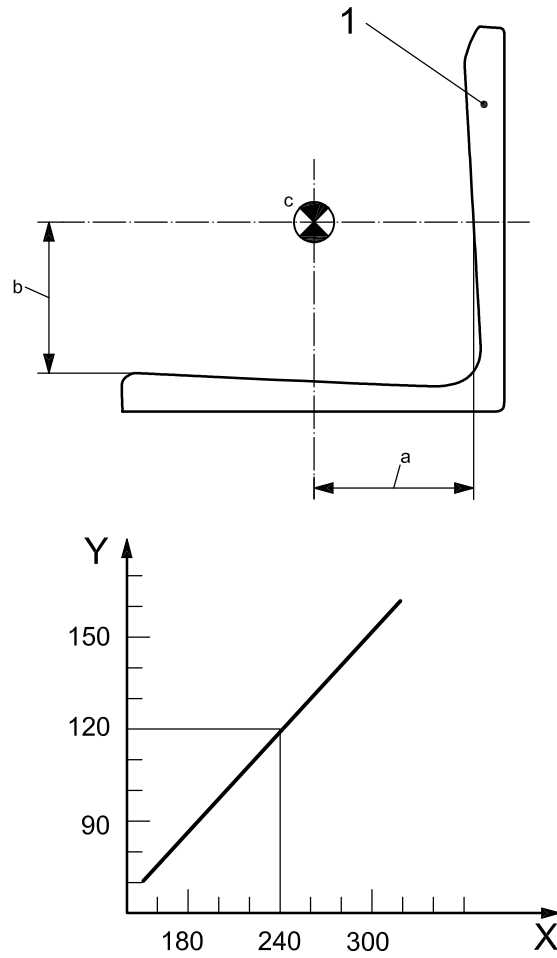

Key

- X width in millimetres
- Y load in kilogrammes
- 1 backrest

- a Width, in millimetres = $2 \times$ maximum load in kilogrammes.
- b Height = 200 mm.
- c Centre of gravity.

NOTE Dimension "a" starts where dimension "b" contacts the backrest.

Figure 3 — Placing of loads on rigid body-supports

Dimensions in millimetres

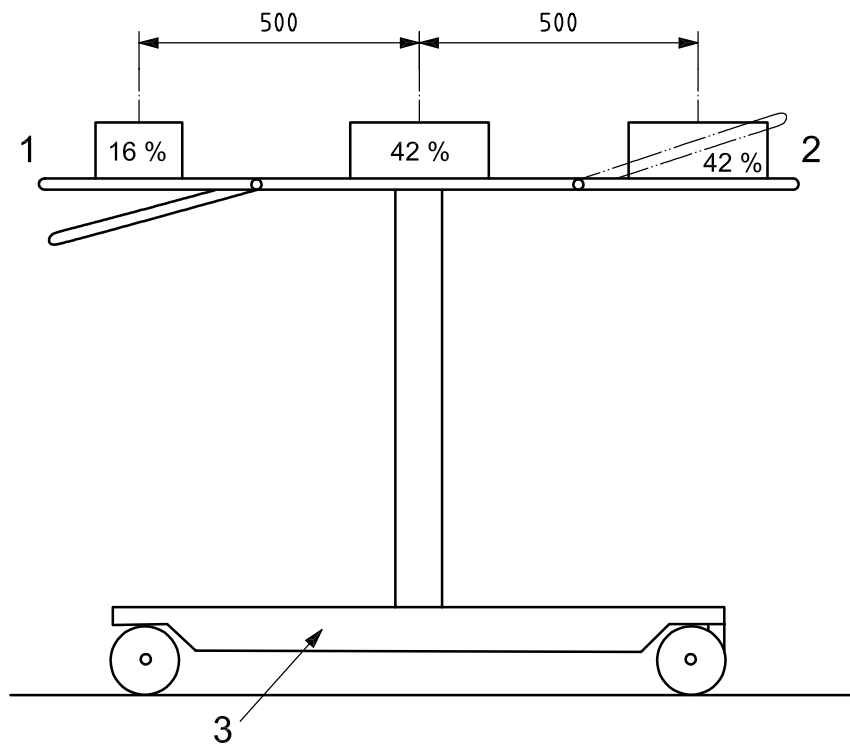

Key

1 feet 2 head 3 base

a) Front elevation

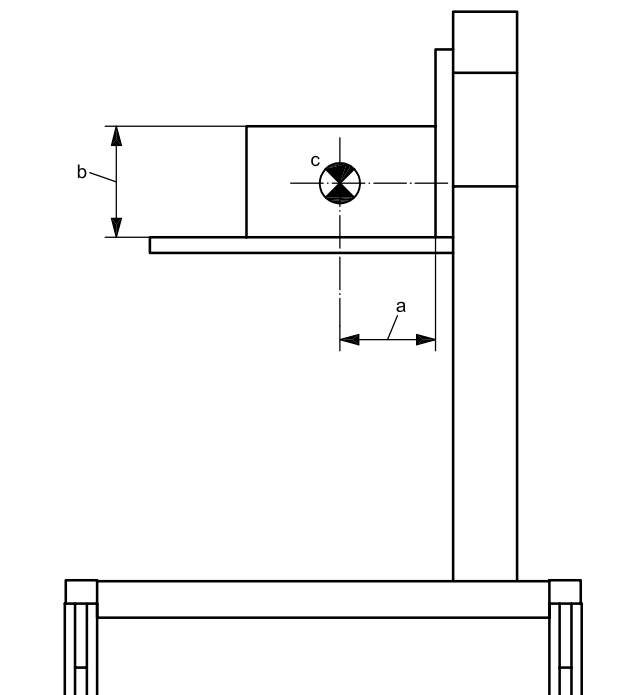

^a Width, in millimetres = $2 \times$ maximum load.

^b Height = 200 mm.

^c Centre of gravity.

NOTE Dimension "a" starts where dimension "b" contacts the backrest.

b) Side elevation

Figure 4 — Placing of loads on fixed stretcher

4.3 Safety requirements

4.3.1 Safety and performance requirements

4.3.1.1 Every hoist shall be capable of lifting a person of 120 kg mass excluding the mass of any body-support unit.

4.3.1.2 Electrically operated hoists shall conform to IEC 60601-1 regarding electrical safety unless requirements are covered by this International Standard. For electrical safety covered by both standards, the requirements of this International Standard prevail over the ones given in IEC 60601-1.

4.3.1.3 The manufacturer shall ensure that the choice of materials used in the construction of the hoist shall be well suited to the intended area of use.

4.3.1.4 Materials which come into contact with the human body shall be assessed for biocompatibility using the guidance given in ISO 10993-1. The assessment shall take into account the intended use and contact by the users.

4.3.1.5 All load-bearing fasteners shall be either self-locking or fitted with a locking device to prevent inadvertent detachment.

4.3.1.6 Single use components (e.g. wood screws or self-tapping screws), shall not be used for the assembly of any component that is intended to be removed for the purpose of dismantling for transport or storage.

4.3.1.7 Handgrips shall be fixed in such a manner as to prevent inadvertent detachment.

4.3.1.8 Unless required for a specific function of the hoist, all accessible edges, corners and surfaces shall be smooth and have no burrs or sharp edges. All projections shall be avoided or fitted with adequate protection to prevent damage or injury.

4.3.1.9 It shall not be possible to assemble the hoist in a manner which affects the overall safety of the unit. If the lifting device incorporates a mast, it shall be so located in relation to its base that it can only be assembled or adjusted in the correct safe working position.

If the design of the hoist is such that the load is allowed to move in a horizontal manner, then the hoist shall not move or operate unless the hoist has been properly secured to prevent inadvertent tipping.

4.3.1.10 Protection against shearing, crushing, trapping and abrading shall be provided and shall be in accordance with the requirements of IEC 60601-1.

4.3.1.11 The hoist shall include in its design some means (e.g., limiting switches, the principal of free-wheeling, etc.) that will ensure that, when lowering, should the spreader bar or lifting arm come into contact with the lifted person, the total load imposed on the lifted person shall not be greater than the total mass of those parts and shall not increase by more than 50 N due to the lifting machinery of the hoist.

4.3.1.12 When a hoist is used in accordance with the manufacturer's instructions, should a part of a person become trapped during a horizontal transfer, then the total force imposed on that person shall not increase by more than 100 N due to the machinery of the hoist.

4.3.1.13 When operated, the means provided in 4.3.1.11 shall not allow the hoist to become unsafe.

4.3.1.14 All controls, for lowering or raising the lifted person, shall be easily accessible and operable by the person operating the hoist.

4.3.1.15 Electrically operated hoists shall be provided with an emergency device that is readily accessible and is intended to isolate the power supply and to stop any electrically produced mechanical movement which could cause a safety hazard.

Resetting the emergency device shall only be possible as the result of a manual action on the emergency device itself. The action of resetting shall be different to the action of activation.

The emergency device shall be coloured red.

4.3.1.16 On all battery-powered hoists, a warning device(s) shall be provided that will indicate when the battery(ies) require charging.

When this device operates there shall be sufficient power available to complete one full lifting cycle with maximum load.

4.3.1.17 All controls shall be of the 'hold to run' type.

4.3.1.18 The hoist shall be designed in such a way so that it shall not lift more than $1,5 \times$ the maximum load.

4.3.1.19 Hoists shall be provided with a safety device that shall ensure that the lifted person does not fall in the event of a single-fault condition of the lifting machinery. See 4.7 and 9.8.2 of IEC 60601-1:2006.

4.3.1.20 After the static test, in accordance with 4.3.2.20, any flexible device shall show no sign of damage that will affect the function of the hoist as stated by the manufacturer.

4.3.1.21 A connection point shall be so designed that the body-support unit shall not become inadvertently detached.

4.3.1.22 Where necessary, all precautions shall be taken [e.g. by the fitting of a safety devices(s)] to protect the lifted person from inadvertently falling off/from the body-support unit.

4.3.1.23 Electrically operated hoists shall fulfill the requirements specified in IEC 60601-1-2 and shall in addition fulfill the following:

a) Emission

The requirements of IEC 61000-3-2 apply if applicable as specified in IEC 61000-3-2.

The requirements of IEC 61000-3-3-am1 apply if applicable as specified in IEC 61000-3-3-am1.

b) Immunity

Requirements are only applicable to hoists containing electronic devices/components. Electrical motors, mechanical switches and other passive components are not considered electronic devices/components.

In addition to the requirements of IEC 60601-1-2:2005, Clause 36.202.2.1, the hoist shall also be tested with a field strength of 10V/m (RMS value of the unmodulated carrier) in the frequency range of 800 MHz to 2 GHz. The test shall be performed in accordance with IEC 61000-4-3.

If as a result of the application of this test the hoist becomes dangerous or unsafe, the hoist shall be deemed to have failed the test. Furthermore, any unintentional movement of any part of the hoist during the test is not allowed.

It is necessary to assess the risk associated with the hoist when used in close proximity to a mobile telephone or other form of transmitter.

NOTE 1 In this case higher field strength values over a broader range of frequency may apply.

NOTE 2 Hoists are used in a wide range of environments and may be used in the presence of other electrical equipment. The electromagnetic compatibility (EMC) needs to be carefully matched to the intended use of the hoist.

4.3.1.24 Any electrical component that can be splashed, during 'normal' operation shall have an IP rating of at least IP×4. Any electrical component that can be submerged during normal operation shall have an IP rating of at least IP×7.

4.3.1.25 The connection point(s) shall be smooth, thus avoiding excessive wear of any connectors.

4.3.1.26 Where a stretcher system is suspended from the CSP of the hoist, the stretcher shall be marked to ensure that the patient is correctly positioned according to the intended use as stated by the manufacturer (eg., head end/foot end) For an example of marking of stretcher, see Figure 5.

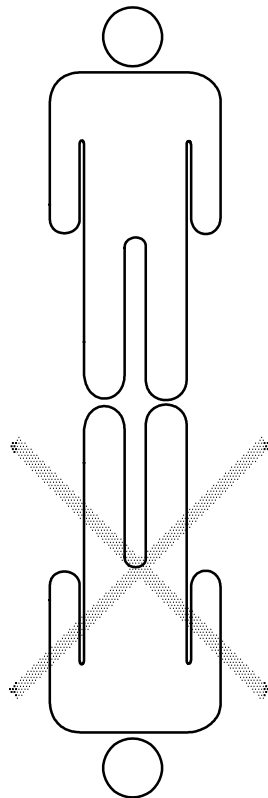

Figure 5 — Example of marking of stretcher

4.3.2 Test methods for general safety requirements

4.3.2.1 The requirements described in 4.3.1.1 shall be confirmed through practical test and inspection.

4.3.2.2 The requirements described in 4.3.1.2 shall be determined by verification in accordance with IEC 60601-1.

4.3.2.3 The requirements described in 4.3.1.3 shall be determined through inspection.

4.3.2.4 The result of the assessment for biocompatibility will provide verification methods.

4.3.2.5 The requirements described in 4.3.1.5 shall be determined through inspection.

4.3.2.6 The requirements described in 4.3.1.6 shall be determined through inspection.

4.3.2.7 The requirement described in 4.3.1.7 shall be determined by testing as follows, according to the following procedure:

- a) with the hoist standing on a horizontal and smooth test plane, set up the 'loading method' in accordance with Figure 6, method A or method B;
- b) prevent the hoist from tipping and/or moving;
- c) if necessary, fit some means of restraint that will support the handle and prevent it flexing under the test load; this restraint shall not touch the handgrip being tested;
- d) slowly apply a force to each handgrip in the direction that simulates the pushing of the hoist until a maximum of 750 N is reached;
 - 1) maintain the load for a period of between 5 s and 10 s;
 - 2) remove the load;
- e) repeat the above test with the load applied in the direction that simulates the pulling of the hoist.

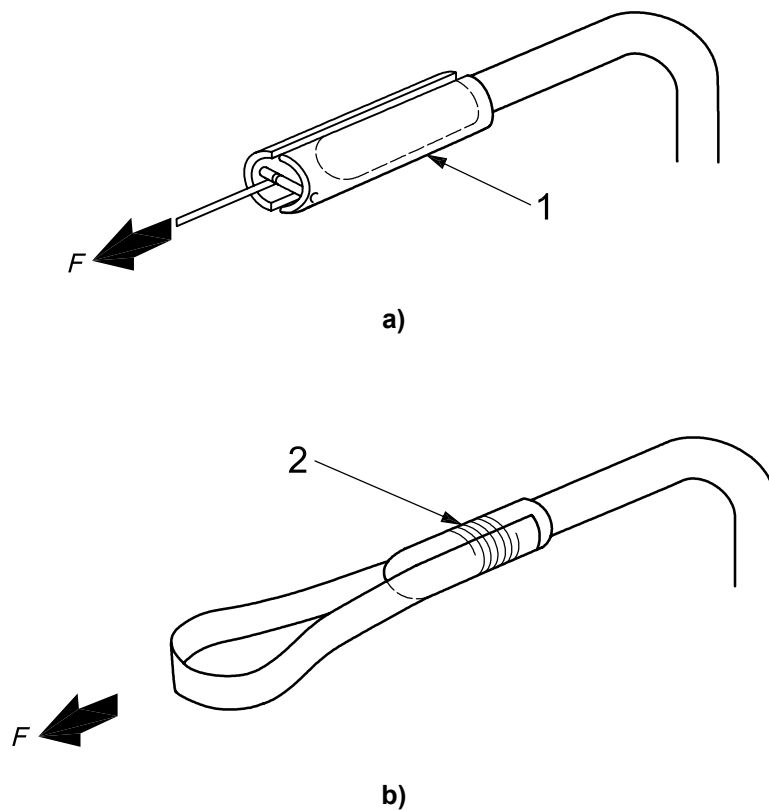

Key

Method A:

1 split tube secured with adhesive

$F = 750 \pm 3 \%$

Method B:

2 webbing strap secured with adhesive (bound in place with string until adhesive secure)

$F = 750 \pm 3 \%$

Figure 6 — Handgrip loading methods

- 4.3.2.8** The requirements described in 4.3.1.8 shall be determined through inspection.
- 4.3.2.9** The requirements described in 4.3.1.9 shall be determined through inspection and functional test.
- 4.3.2.10** The requirements described in 4.3.1.10 shall be determined through inspection and/or manufacturer's technical documentation and in accordance with the requirements in EN 12182.
- 4.3.2.11** The requirements described in 4.3.1.11 shall be tested by driving the spreader bar (or other part of the hoist that is used to support the body-support unit) with no load, down and on to a solid surface that incorporates a load-sensing device. The hoist shall not impart a load that is in excess of the combined mass of the body-support unit, the spreader bar and the lifting arm, etc., plus 50 N.
- 4.3.2.12** The requirements described in 4.3.1.12 shall be tested in the following manner.

An assessment shall be made which will determine the potential trapping points.

Once determined, a load cell shall be placed between the potential trapping point and a solid vertical surface. The force indicated by the load cell shall not exceed 100 N when the hoist is powered in a horizontal manner. The test shall be performed both with no load and with maximum load.

- 4.3.2.13** The requirements described in 4.3.1.13 shall be determined through functional test.
- 4.3.2.14** The requirements described in 4.3.1.14 shall be determined through functional test.
- 4.3.2.15** The requirements described in 4.3.1.15 shall be determined through functional test.
- 4.3.2.16** The requirements described in 4.3.1.16 shall be determined through functional test.
- 4.3.2.17** The requirements described in 4.3.1.17 shall be determined through inspection.
- 4.3.2.18** When loaded with a mass as described in 4.3.1.18, the hoist shall be prevented from lifting.
- 4.3.2.19** The requirement described in 4.3.1.19 shall be determined by verification and, where possible, inspection.
- 4.3.2.20** The requirement described in 4.3.1.20 shall be determined as follows.

Flexible devices used for lifting shall be tested separately. They shall be loaded statically with $6 \times$ maximum load for 20 min. Locking systems used in the lifting process shall be tested separately. They shall be loaded statically with $4 \times$ the maximum load for 20 min and the results determined by inspection.

- 4.3.2.21** The requirements described in 4.3.1.21 shall be determined through inspection and functional test.
- 4.3.2.22** The requirements described in 4.3.1.22 shall be determined through inspection and judgement.
- 4.3.2.23** The requirements described in 4.3.1.23 shall be determined through verification in accordance with IEC 60601-1-2.
- a) The requirements described in 4.3.1.23 a) shall be determined through verification in accordance with IEC 61000-3-2 and IEC 61000-3-3-am1.
- b) The requirements described in 4.3.1.23 b) shall be determined through verification in accordance with IEC 61000-4-3 and IEC 60601-1-2.
- 4.3.2.24** The requirements described in 4.3.1.24 shall be determined through verification in accordance with IEC 60529.
- 4.3.2.25** The requirements described in 4.3.1.25 shall be determined through inspection.

4.3.2.26 The requirements described in 4.3.1.26 shall be determined through inspection.

4.4 Requirements for body-support units

The manufacturer of the body-support unit shall indicate with which hoist(s) (as specified in the scope) and spreader bar(s) it is compatible in order to ensure a safe combination.

The method by which the body-support unit can be adjusted or removed shall be clearly stated in the accompanying operating instructions.

4.5 Central suspension point

4.5.1 Requirements for central suspension point

The central suspension point (CSP) shall be constructed in such a way as to prevent inadvertent detachment of the spreader bar during normal usage.

4.5.2 Test method for the central suspension point

The requirements of 4.5.1 shall be verified by functional test.

4.6 Spreader bar

4.6.1 Requirements for spreader bar

4.6.1.1 If the width of the spreader bar is designed to be adjustable in use then a safety device shall be incorporated to ensure that the spreader bar or body-support unit cannot become inadvertently detached.

4.6.1.2 The spreader bar shall be capable of supporting at least $1,5 \times$ the maximum load of the hoist on which it is mounted.

4.6.1.3 In the instructions for use, information shall be given about the type(s) and design(s) of body-support units, e.g. number of connection points, dimensions and material of connection means, which can be used in combination with the spreader bar.

NOTE This information can also be given on the spreader bar.

4.6.1.4 Detachable spreader bars shall be marked with the maximum load of the hoist.

4.6.2 Test methods for the spreader bar

4.6.2.1 The requirements of 4.6.1.1 shall be determined through inspection and functional test.

4.6.2.2 The requirements of 4.6.1.2 shall be confirmed after the static strength test.

4.6.2.3 The requirements of 4.6.1.3 shall be determined through inspection.

4.6.2.4 The requirements of 4.6.1.4 shall be determined through inspection.

4.7 Performance

4.7.1 Requirements for performance

4.7.1.1 The hoist shall be designed for the purpose of transferring a disabled person according to the field of application, as stated by the manufacturer and it shall be able to be operated by one person. If not, this shall be stated in the instructions for use.

NOTE When being used in the designated manner, the hoist should enable the disabled person to be positioned in such a way as to minimize the need for attendant repositioning.

4.7.1.2 Unless specifically designed to do so, the hoist shall not contain any cavities in which liquid could accumulate.

4.7.1.3 When loaded with the maximum load, the CSP shall have a stopping distance of not more than 50 mm.

4.7.2 Test methods for performance

4.7.2.1 The requirements described in 4.7.1.1 shall be determined through inspection and judgement.

4.7.2.2 The requirements described in 4.7.1.2 shall be determined through inspection and functional test.

4.7.2.3 The requirements described in 4.7.1.3 shall be determined in the following manner:

- a) load the hoist with maximum load;
- b) set the CSP to top position;
- c) lower the CSP at full speed;
- d) at a position approximately equal to the middle of the lifting range, remove the energy source from the hoist by either releasing the relevant control button, closing the relevant valve(s) or by ceasing to wind manually;
- e) measure the vertical distance from this point to the point where the lowering stops.

4.8 Rate (velocity) of lifting and lowering

4.8.1 Requirements for rate (velocity) of lifting and lowering

4.8.1.1 The rate of lifting or lowering the CSP ("reference point" on bathtub hoists) shall not exceed 0,15 m/s when loaded.

4.8.1.2 The rate of lifting or lowering the CSP ("reference point" on bathtub hoists) shall not exceed 0,25 m/s when unloaded.

4.8.2 Test methods for rate (velocity) of lifting and lowering

4.8.2.1 When measured with the maximum load, the rate of lifting and lowering shall not exceed the velocity stated in 4.8.1.1.

4.8.2.2 When measured unloaded, the rate of lifting and lowering shall not exceed the velocity stated in 4.8.1.2.

4.9 Operating forces/torques

4.9.1 Requirements for operating forces/torques

The operating forces or torques required for those parts of the hoist that are designed to be operated by fingers, hands/arms or feet shall not exceed the following values:

- a) operation by using a finger: 5 N
- b) operation by using a hand/arm: 105 N

- c) operation by using a foot: 300 N
- d) operation by a turning: 1,9 N·m

NOTE For hoists operated by disabled persons or other non-professionals, Annex C in EN 12182:1999 can be used as a guideline.

4.9.2 Test methods for operating forces/torques

With the hoist under the maximum load, the operating forces/torques of all the controls stated in 4.9.1, shall be measured. These measurements shall be taken at the mid-point of intended use as stated by the manufacturer.

4.10 Durability

4.10.1 Requirements for durability

After testing in accordance with the requirements of 4.10.2, the hoist shall function as intended with the maximum load as well as when unloaded, and shall show no signs of permanent deformation or wear that may affect its function.

4.10.2 Test methods for durability

4.10.2.1 In the case of mobile hoists they shall be placed on a horizontal surface with the base locked in the most adverse position. The hoist shall be secured against moving on the surface.

4.10.2.2 In the case of stationary hoists, they shall be fixed/mounted/placed in the most adverse condition in accordance with the manufacturer's installation instructions.

4.10.2.3 For manually operated hydraulic hoists, the stroke of the pump lever shall be as long as possible but the end stops of the pump shall not be activated at any time.

4.10.2.4 The working:pause ratio (duty cycle) during test shall be 15:85, if not otherwise stated by the manufacturer. If the hoist is intended to be operated at varying speeds then the durability test will be performed using the speed that represents the most adverse condition as stated by the manufacturer.

4.10.2.5 If necessary, it is permissible to use an alternative power supply instead of the battery for the purpose of durability test only, as agreed with the manufacturer of the hoist.

4.10.2.6 Maintenance during testing shall only be carried out if specifically required by the manufacturer in his service manual.

4.10.2.7 The hoist shall be loaded so as to reflect the loading that would be applied to the hoist in normal use. For hoists with rigid body-support and fixed stretchers the load shall be positioned as shown in Figures 3, 4 a) and 4 b). For hoists with suspended stretchers the load shall be positioned as shown in Figure 7. Raise and lower the hoist 250 mm or 25 % of the vertical movement, whichever is the greater in the lifting range, as stated in 4.10.2.8. Ensure that the pause in the lifting cycle and the loading and unloading always occurs when the hoist is at the lowest position of the lifting cycle.

4.10.2.8 Repeat the lifting cycle of the hoist for a total of 11 000 lifting cycles, according to the following schedule, and conduct the tests in the order shown.

- a) Raise and lower the CSP of the hoist at its maximum velocity with no load for 1 000 cycles ensuring that the top limiting device(s) is(are) activated.
- b) 1 000 lifting cycles with the maximum load at the lower end of the lifting range of the hoist: for electrical hoists, activate the lower end limiting device for approximately 1 s in every lifting cycle. For hoists with

only one horizontal axis of rotation of the spreader bar, the test shall be performed with 1/3 of the load on one side and 2/3 of the load on the other side of the spreader bar.

- c) 1 000 lifting cycles with the maximum load at the top of the lifting range of the hoist: for electrical hoists activate the top-end limiting device for approximately 1 s in every lifting cycle.
- d) 8 000 lifting cycles with the maximum load, in the middle of the lifting range of the hoist.

NOTE The above tests are designed to simulate the 'normal use' of the hoist.

4.10.2.9 During the lifting cycle the load shall be allowed to adjust to the vertical in such a way that the swing induces only a negligible dynamic element.

Dimensions in millimetres

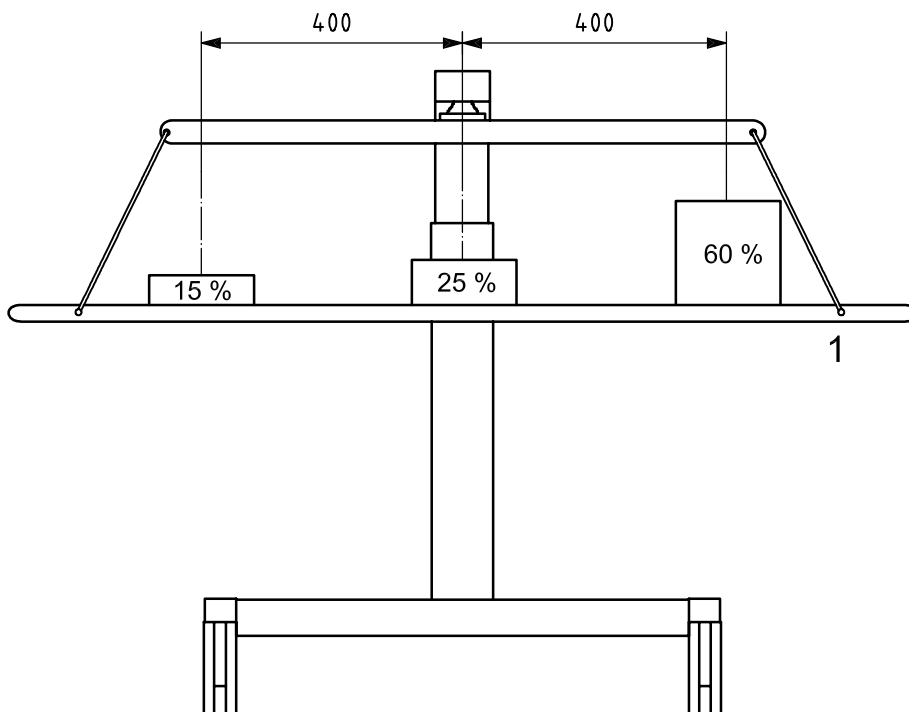

Key
1 head end

NOTE Schematic presentation only.

Figure 7 — Placing of loads on a suspended stretcher

4.11 Hydraulic components

4.11.1 Requirements for hydraulic components

4.11.1.1 Hydraulic actuators, including all hoses, pipes, connectors and other components on the pressure side, must be rated to account for all loads occurring through pressure force. In addition, they shall be compatible with the hydraulic fluid being used, and be designed to take account of direct stresses induced by torsion, vibration and physical damage.

4.11.1.2 The requirements for hydraulics are deemed to be met if:

- a) for outer cylinders, the dimensions have been calculated in accordance with EN 13480-3:2002; if the calculations are made using only the static pressure, then it shall be assumed that the calculated pressure will be $1,8 \times$ the actual static pressure;
- b) for rigid pipes and fittings, the dimensions of the pipes and associated fittings have been calculated in accordance with EN 13480-3:2002; if the calculations are made using only the static pressure, then it will be assumed that the calculated pressure will be $2 \times$ the actual static pressure;
- c) for flexible hoses, the hoses are manufactured to the requirements of EN 853 or EN 854.

4.11.1.3 A non-return valve shall be fitted, which shall be capable of holding the rated load of the hoist at any point when the supply pressure drops below the minimum operating pressure.

4.11.1.4 Closing of the non-return valve shall be effected by the hydraulic pressure from the jack and by at least one guided spring and/or by gravity.

4.11.1.5 A pressure-relief valve shall be fitted, which shall be adjusted to limit the pressure to $1,5 \times$ the full load pressure. The relieved hydraulic fluid shall be returned to the reservoir.

4.11.1.6 The hydraulic system shall be capable of being bled of air.

4.11.1.7 For powered hydraulic systems, means shall be provided to easily check the level of the hydraulic fluid in the reservoir.

4.11.2 Test methods for hydraulic components

4.11.2.1 The requirements 4.11.1.1 and 4.11.1.2 are tested through verification of calculations and dimensions.

4.11.2.2 The requirements 4.11.1.3 to 4.11.1.7 are tested through inspection and functional test.

4.12 Pneumatic components

4.12.1 Requirements for pneumatic components

4.12.1.1 In addition to the requirements stated in 4.11, the following shall apply.

4.12.1.2 Pneumatic actuators, including all hoses, pipes, connectors and other components on the pressure side, shall be rated to account for all loads occurring through pressure force.

4.12.1.3 Means shall be provided that prevent pressure in working cylinders and air bellows exceeding $1,5 \times$ the static pressure caused by the application of the maximum load. The means provided shall be protected against adjustment by unauthorized personnel.

4.12.2 Test methods for pneumatic components

4.12.2.1 The requirements of 4.12.1.1 are tested through verification of calculations and dimensions.

4.12.2.2 The requirements of 4.12.1.2 are tested through inspection and functional test.

4.12.2.3 The requirements of 4.12.1.3 are tested through inspection and functional test.

4.13 Information supplied by the manufacturer

4.13.1 General

The requirements of EN 980 and EN 12182 apply.

4.13.2 Marking

All operating controls shall be marked for their intended function.

Every hoist (and any main part of a multi-purpose hoist) and body-support unit shall be permanently marked with at least the following information:

- a) name and address of the manufacturer and, in addition, name and address of the supplier if different from the manufacturer;
- b) model definition;
- c) lot or batch and/or serial number;

NOTE Serial number is preferred for traceability and inspection records.

- d) year and month of manufacture;
- e) electrical details in accordance with IEC 60601-1, if and where applicable;
- f) details of any other energy source used (e.g. water/air operated, operating pressure range);
- g) maximum load;
- h) the product IP rating (where applicable; see 4.3.1.24).

4.13.3 Instructions for use

The purchaser of any hoist and/or body-support unit shall be provided with an instruction leaflet which shall include at least the following information (where applicable):

- a) name and address of the manufacturer, supplier or agent;
- b) check list before use;
- c) the intended use of the hoist and body-support unit;
- d) expected lifetime of the product;
- e) sufficient drawings/illustrations in order to show the key dimensions described in i) below;
- f) name, address and telephone number to contact for service;
- g) method of cleaning and disinfection, and maintenance information;
- h) details for trouble shooting/assistance;
- i) technical specifications:
 - dimensions (to include those shown in Figures 1, 8, 9, 10, 11 and 12 where appropriate),
 - maximum load,

- safety precautions (to include, if necessary, the fact that if the maximum load differs between hoist, spreader bar and body-support unit, then the lowest maximum load shall always be used),
 - total mass of the unloaded hoist and, where appropriate, the masses of any main part that can be dismantled (e.g. for transportation),
 - the A-weighted sound power level (see 4.1.3),
 - operating forces of controls,
 - the designs and types of body-support units to be used in combination with the spreader bar;
- j) electrical information in accordance with IEC 60601-1;
- k) limits of accuracy of any measuring device, any warning/attention marks used on the product shall be explained in more detail in the operating instructions;
- l) all the information needed to verify whether the device is properly installed and can operate correctly and safely, plus details of the nature and frequency of the maintenance and calibration needed to ensure that the devices operate properly and safely at all times (see guidance given in Annex B);
- NOTE See also Non-Automatic Weighing Instruments 90/384/EEC and its harmonized standard.
- m) a list of replacable spare parts shall be available on request;
- n) any warning according to the risk assessment (e.g. for mobile hoists, be aware of stability problems due to side forces imposed on the patient);
- o) an indication of the forwards direction of travel.

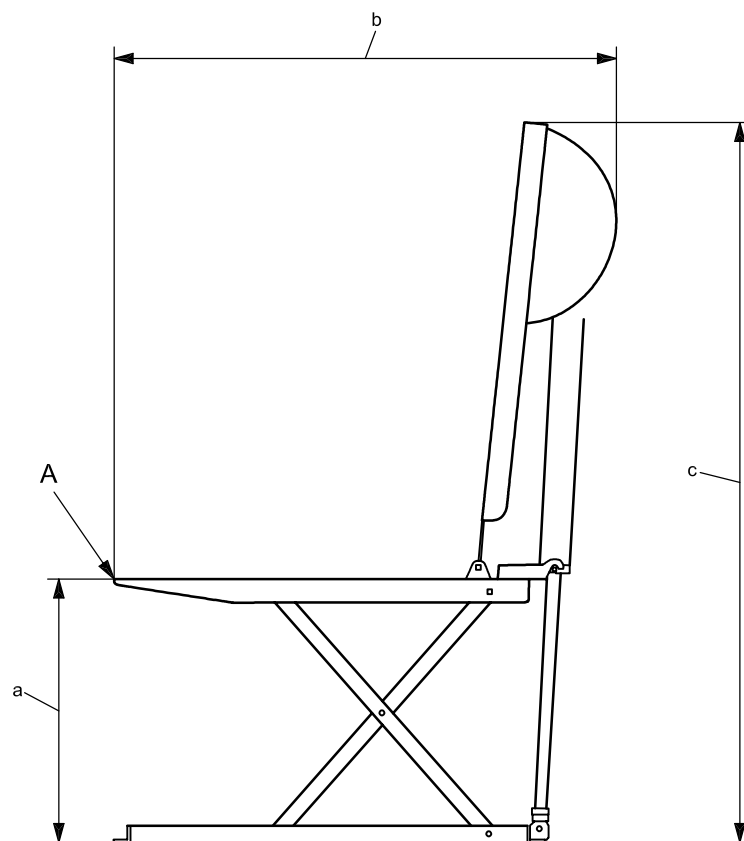

- a Height of seat in its highest position.
- b Overall length in highest position.
- c Overall height in highest position.
- A reference point measured half way across the width of the body-support unit

Figure 8 — Key dimensions in highest position of bathtub hoist

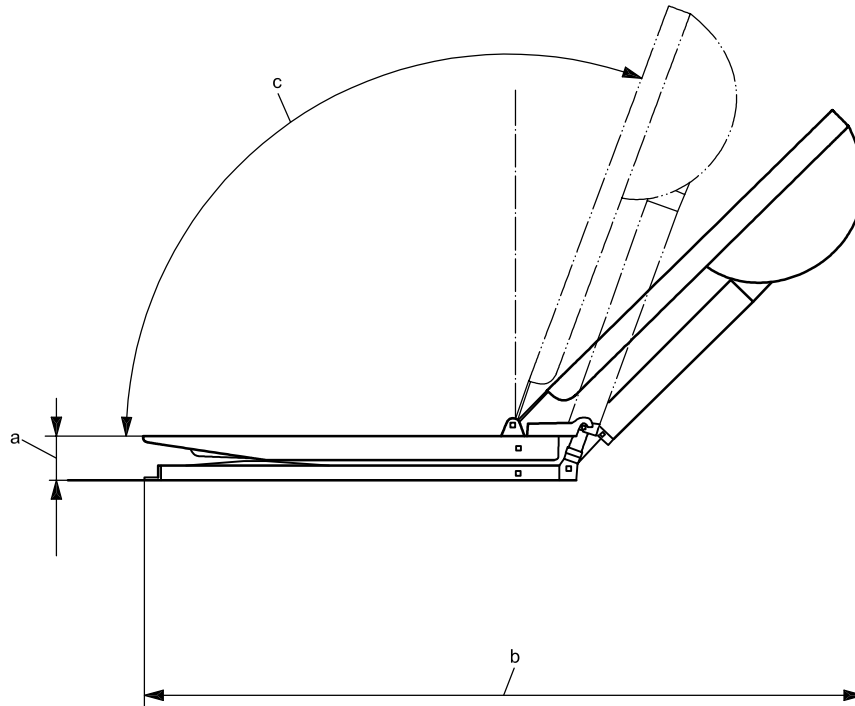

- a Height of seat in its lowest position.
- b Overall length in lowest position.
- c Minimum angle of backrest.

NOTE Schematic presentation only.

Figure 9 — Key dimensions in lowest position of bathtub hoist

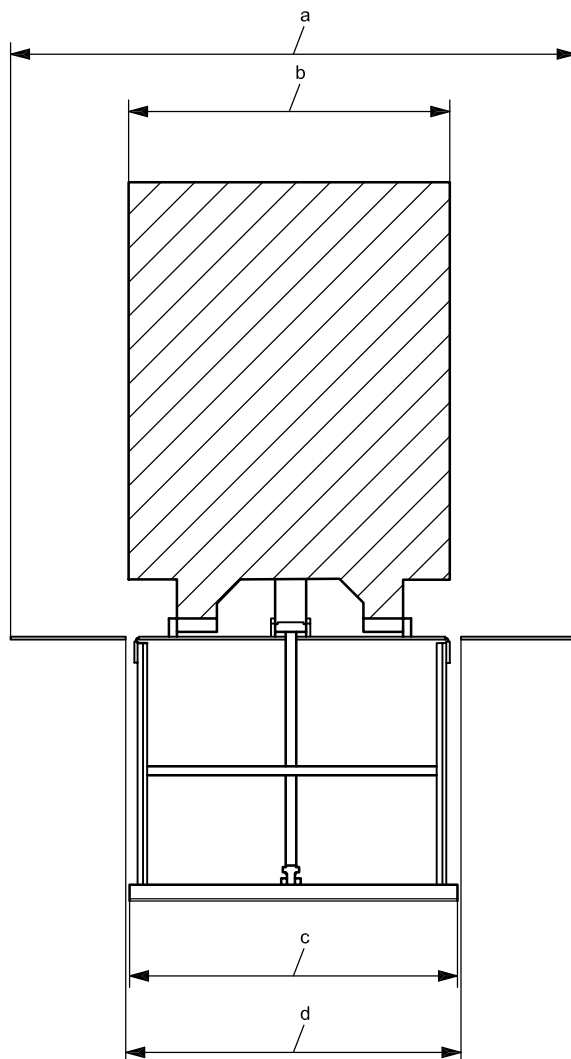

- a Width of seat with extended seat flaps.
- b Width of backrest.
- c Width of basis plate.
- d Width of seat excluding side flaps.

Figure 10 — Key dimensions with extended seat side flaps of bathtub hoist

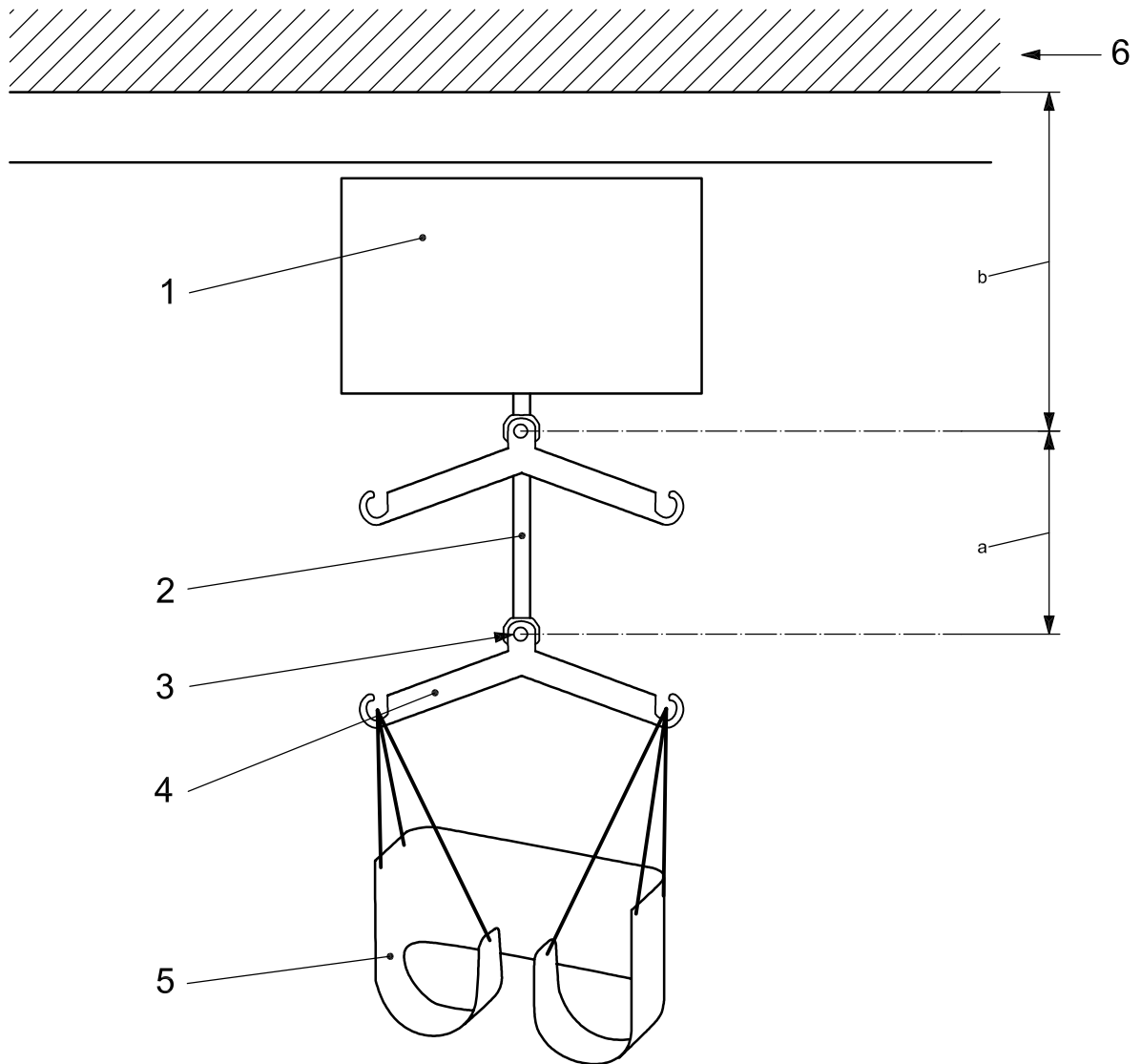

Key

- 1 lifting machine
- 2 flexible device
- 3 CSP
- 4 spreader bar
- 5 non-rigid body support
- 6 ceiling

a Hoisting range.

b Minimum distance from ceiling to CSP.

Figure 11 — Key terminology and dimensions for ceiling hoist

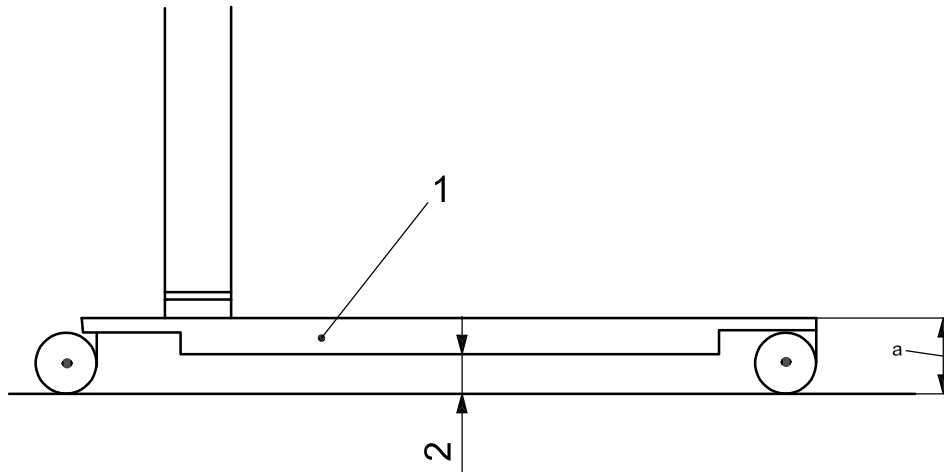

- Key**
- 1 base
 - 2 clearance
 - ^a Base height.

Figure 12 — Base height/clearance

5 Mobile hoists — Specific requirements and test methods

5.1 General requirements

This clause specifies requirements and test methods for mobile hoists, which are additional to those specified in Clause 4.

5.2 Static strength

5.2.1 Requirements for static strength

After the static test as defined in 5.2.2, the hoist shall function as defined by the manufacturer. There shall be no deformation or wear that may affect its function.

5.2.2 Test methods for static strength

The hoist and lifting devices shall be loaded statically according to the procedures and order described below [see Figures 4 a), 4 b), and 6]. The hoist shall be loaded as to reflect the loading that would be applied to the hoist in normal use.

The hoist shall be placed on an inclined surface and secured against tipping but not against deformation. The lifting boom/actuator shall be set in the most adverse position. The hoist shall then be loaded with $1,25 \times$ maximum load for 5 min in the following directions:

- a) 10° forwards;
- b) 10° backwards;
- c) 5° sideways in the most adverse direction (both left and right sides where applicable).

The test is then performed with the surface horizontal and with $1,5 \times$ maximum load for 20 min.

5.3 Static stability

5.3.1 Requirements for static stability

During the static stability test according to 5.3.2, both unloaded and under maximum load, the hoist shall not lose its equilibrium (balance) at the following angles:

- a) forwards and backwards directions 10° with the base in the intended travelling position;
- b) forwards and backwards directions 7° with the base in the most adverse condition;
- c) any other direction, 5°.

5.3.2 Test methods for static stability

5.3.2.1 Test procedures for 5.3.1 a), b) and c)

- a) The tests shall be carried out in the forwards and backwards travelling directions and with the base in the travelling position as indicated by the manufacturer and with the load placed in the most adverse position.
- b) The tests shall be carried out in the forwards and backwards directions and in the most adverse direction. If there is more than one intended direction of travel (forwards) they shall all be regarded as forwards.
- c) The tests shall be carried out with the hoist in its most adverse position regarding the position of the wheels, CSP, base and brakes.

5.3.2.2 Unloaded

Position the unloaded hoist on the test surface with the wheels towards the stop(s) (see Figure 13).

Incline the test plane gradually until the hoist loses its equilibrium (balance). Record the angle of inclination.

Repeat the test in the backwards and sideways directions.

5.3.2.3 Loaded

Attach the maximum load to the hoist's CSP in such a way that the load is able to move freely. Repeat the procedure as for the unloaded hoist. For hoists with rigid body supports, the centre of gravity of the load shall be placed in relation to the backrest according to Figure 3, but not more than 350 mm from the front edge of the seat.

For stretchers that are suspended from a hoist, apply the loads as shown in Figure 7.

For stretchers that are not suspended from a hoist, apply the loads as shown in Figures 4 a) and 4 b).

5.4 Immobilizing device (brakes)

5.4.1 Requirements for immobilizing device (brakes)

An immobilizing device shall be provided for mobile hoists. When tested in accordance with 5.4.2, a maximum movement of 10 mm in any direction is allowed.

5.4.2 Test methods for immobilizing device (brakes)

To ensure that the requirement described in 5.4.1 is fulfilled, a hoist shall be positioned on a 1° slope with the immobilizing device(s) activated. The maximum load shall be applied to the hoist in the most adverse position. Hold that position for a minimum time period of 1 min and measure the distance the device has moved.

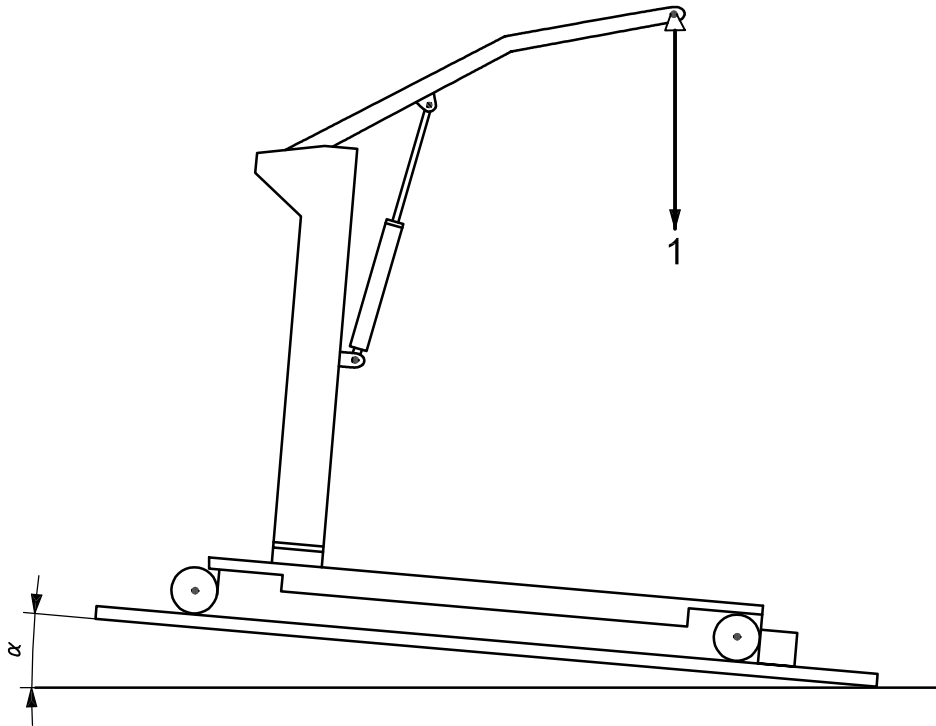

- Key**
- 1 test load
 - α stability angle

Figure 13 — Example of forward stability test

5.5 Moving forces

5.5.1 Requirements for moving forces

The maximum forces required for moving the hoist shall be as follows when tested with the maximum load on the hoist:

- a) starting: 160 N
- b) driving (pushing/pulling): 85 N

5.5.2 Test methods for moving forces

The test shall be carried out on a flat, smooth and horizontal steel plate.

The hoist shall be loaded with the maximum load with the lifting arm set to obtain the maximum reach.

For the test in the forwards and backwards directions, the castors shall be set at 180° to the direction of pushing/pulling.

Using a dynamometer, a starting force is gradually applied to the push handle until the hoist begins to move. Repeat five times. The highest force noted during these tests shall be recorded as the starting force.

The starting force shall be applied and recorded as follows:

- a) in the forwards direction;
- b) in the backwards direction.

5.6 Instructions for use

This subclause specifies requirements for mobile hoists in addition to those specified in 4.13.3.

The manufacturer shall provide at least the following information:

- a) functional dimensions as given in Figures 1, 12 and 14;
- b) the turning diameter;
- c) the total mass of the hoist excluding body-support unit;
- d) the number of parts and the identification of those parts into which the hoist can be disassembled;
- e) the mass of the heaviest detachable part of the hoist.

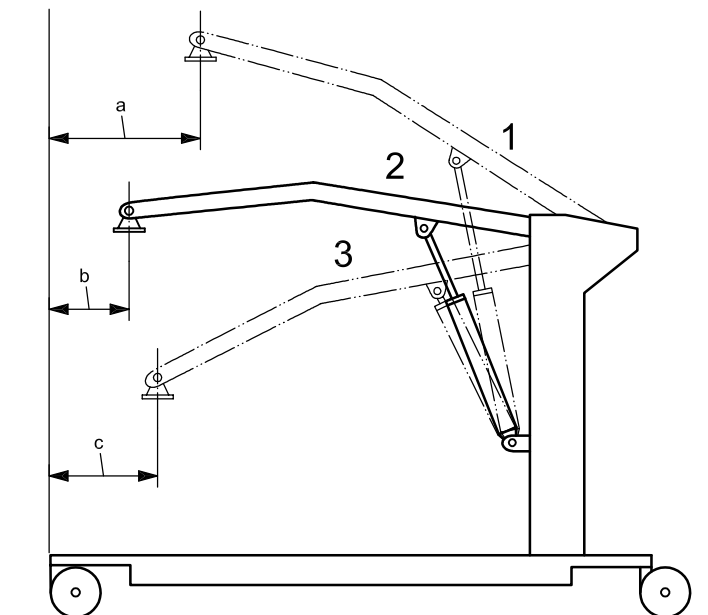

Key

- 1 highest position
- 2 mid position
- 3 lowest position

- a Minimum distance from wall to CSP at maximum height (legs spread).
- b Minimum distance from wall to CSP at maximum reach (legs spread).
- c Minimum distance from wall to CSP at minimum height (legs spread).

NOTE Schematic presentation only.

Figure 14 — Key dimensions of mobile hoists

6 Standing and/or raising hoists — Specific requirements and test methods

6.1 General requirements

This clause specifies requirements and test methods for standing and/or raising hoists which are additional or modifications to those specified in Clause 4. Standing and/or raising hoists shall not fulfill the requirements in Clause 5, as the applicable requirements have been included in the present clause.

6.2 Static strength

6.2.1 Requirements for static strength

After the static test as defined in 6.2.2, the hoist shall function as defined by the manufacturer. There shall be no deformation or wear that may affect its function.

6.2.2 Test method for static strength

The hoist and lifting devices shall be loaded statically according to the procedures and order described below.

The hoist shall be placed on an inclined surface and secured against tipping but not against deformation. The lifting arms and/or hooks shall be set in the most adverse position. With no load being supported by the footrest, the hoist shall be loaded to a maximum for 20 min in the following directions:

- a) 10° forwards;
- b) 10° backwards;
- c) 5° sideways in the most adverse direction (both left and right sides where applicable).

The test is then performed with the surface horizontal and with $1,5 \times$ maximum load for 20 min.

The test is then performed using a load equal to $1,25 \times$ the maximum load (using a dummy as shown in Figure 2) with the centre of the load placed in the most adverse position on the footrest in which failure is most likely to occur, for 5 min.

6.3 Static stability

6.3.1 Requirements for static stability

During the static stability test according to 6.3.2, both unloaded and under maximum load applied using the dummy as shown in Figure 2, the hoist shall not lose its equilibrium (balance) at the following angles:

- a) forwards and backwards directions 10° with the base in the intended travelling position;
- b) forwards and backwards directions 7° with the base in the most adverse condition;
- c) any other direction, 5°.

6.3.2 Test methods for static stability

6.3.2.1 Test procedures for 6.3.1 a), b) and c)

The following tests will be carried out using the test dummy as described in Figure 2.

- a) The tests shall be carried out in the forwards and backwards travelling directions and with the base in the travelling position as indicated by the manufacturer and with the load placed in the most adverse position.

- b) The tests shall be carried out in the forwards and backwards directions and in the most adverse direction. If there is more than one intended direction of travel (forwards) they shall all be regarded as forwards.
- c) The tests shall be carried out with the hoist in its most adverse position regarding the position of the wheels, CSP, base and brakes.

6.3.2.2 Unloaded

Position the unloaded hoist on the test surface with the wheels towards the stop(s) (see Figure 13).

Incline the test plane gradually until the hoist loses its equilibrium (balance). Record the angle of inclination.

Repeat the test in the backwards and sideways directions.

6.3.2.3 Loaded (backwards stability)

Position the hoist on the test surface with the wheels towards the stop(s) (see Figure 13).

Using the dummy shown in Figure 2, apply the maximum load to the hoist. The dummy shall be in the most upright position the hoist is able to achieve.

Incline the test plane gradually until the hoist loses its equilibrium (balance). Record the angle of inclination.

6.3.2.4 Loaded (forwards stability)

Position the hoist on the test surface with the wheels towards the stop(s) (see Figure 13).

Using the dummy shown in Figure 2, apply the maximum load to the hoist. The dummy shall be in the most adverse position the hoist is able to achieve.

Incline the test plane gradually until the hoist loses its equilibrium (balance). Record the angle of inclination.

6.3.2.5 Loaded (sideways stability)

Position the hoist on the test surface with the wheels towards the stop(s) (see Figure 13).

Using the dummy shown in Figure 2, and having the body-support unit (if fitted) at its maximum length, apply the maximum load to the hoist. The dummy shall be in the most adverse position the hoist is able to achieve.

Incline the test plane gradually until the hoist loses its equilibrium (balance). Record the angle of inclination.

6.4 Immobilizing device (brakes)

6.4.1 Requirements for immobilizing device (brakes)

An immobilizing device shall be provided for mobile hoists. When tested in accordance with 6.4.2 a maximum movement of 10 mm in any direction is allowed.

6.4.2 Test methods for immobilizing device (brakes)

To ensure that the requirement described in 6.4.1 is fulfilled, a hoist shall be positioned on a 1° slope with the immobilizing device(s) activated. The maximum load shall be applied to the hoist in the most adverse position using the dummy shown in Figure 2. Hold that position for a minimum time period of 1 min and measure the distance the device has moved.

6.5 Moving forces

6.5.1 Requirements for moving forces

The maximum forces required for moving the hoist when tested with the maximum load on the hoist shall be:

- a) starting: 160 N;
- b) driving (pushing/pulling): 85 N.

6.5.2 Test methods for moving forces

The test shall be carried out on a flat, smooth and horizontal steel plate.

The hoist shall be loaded with the maximum load using the dummy shown in Figure 2 with the lifting arms/hooks set to obtain the maximum reach.

The castors shall be set at 180° to the direction of pushing/pulling.

Using a dynamometer, a starting force is gradually applied to the push handle until the hoist begins to move. Repeat five (5) times. The highest force noted during these tests shall be recorded as the starting force.

The starting force shall be applied and recorded as follows:

- a) in the forwards direction;
- b) in the backwards direction.

6.6 Durability

NOTE The requirements and test methods for durability given in this subclause replace those given in 4.10.

6.6.1 Requirements for durability

After testing in accordance with the requirements of 6.6.2 the hoist shall function as intended with the maximum load and when unloaded, and shall show no signs of permanent deformation or wear that may affect its function.

6.6.2 Test methods for durability

6.6.2.1 The hoist shall be placed on a horizontal surface with the base locked in the most adverse position. The hoist shall be secured against moving on the surface.

6.6.2.2 For manually-operated hydraulic hoists, the stroke of the pump lever shall be as long as possible but the end stops of the pump shall not be activated at any time.

6.6.2.3 The working:pause ratio (duty cycle) during test shall be 15:85, if not otherwise stated by the manufacturer. If the hoist is intended to be operated at varying speeds, then the durability test will be performed using the speed that represents the most adverse condition, as stated by the manufacturer.

6.6.2.4 If necessary, it is permissible to use an alternative power supply instead of the battery for the purpose of durability test only, as agreed with the manufacturer of the hoist.

6.6.2.5 Maintenance during testing shall only be carried out if specifically required by the manufacturer in his service manual.

6.6.2.6 Suspend a load equal to 75 % of the maximum load on the hoist lifting arms and/or hooks. Raise and lower the arms and/or hooks of the hoist through the full stroke/range. Ensure that the pause in the lifting cycle and the loading and unloading always occurs when the hoist is at the lowest position of the lifting cycle.

6.6.2.7 Repeat the lifting cycle of the hoist for 11 000 lifting cycles ensuring that the bottom and top-end limiting devices are activated.

6.6.2.8 During the lifting cycle the load shall be allowed to adjust to the vertical in such a way that the swing induces only a negligible dynamic element.

6.7 Instructions for use

This subclause specifies requirements for standing and/or raising hoists in addition to those specified in 4.13.3.

The manufacturer shall provide at least the following information:

- a) functional dimensions as given in Figures 1, 10 and 14;
- b) the turning diameter;
- c) the total mass of the hoist excluding body-support unit;
- d) the number of parts and the identification of those parts into which the hoist can be disassembled;
- e) the mass of the heaviest part of the hoist.

7 Stationary hoists — Specific requirements and test methods

7.1 General requirements

This clause specifies requirements and test methods for stationary hoists which are additional to those specified in Clause 4.

7.2 Specific safety requirements

7.2.1 Requirements for specific safety requirements

7.2.1.1 Ceiling hoists that are able to move from one "system" to another via a "points or switch" system shall incorporate a locking gate. The locking gate shall be fitted with an interlock device that only allows the hoist to move between one system and the other when the locking gate is in its correct position.

7.2.1.2 If a hoist is able to produce powered horizontal movement, then its linear velocity shall be limited to 0,3 m/s.

7.2.1.3 After the test specified in 7.2.2.3, the hoist and end stop shall not be adversely affected.

7.2.1.4 If the vertical movement of the CSP is limited by using electrical switches, then an additional device shall be fitted to ensure that any failure of the limiting switches does not create a dangerous situation.

7.2.1.5 All hoists shall incorporate an emergency lowering device.

When a hoist is to be used by a disabled person on their own, it is necessary to ensure that in the event of a failure of the hoist, the disabled person is not left in a potentially dangerous situation.

NOTE This may, for example, take the form of a warning in the instructions for use, the fitting of an alarm system or the supply of a conveniently placed telephone, etc.

7.2.1.6 Maximum deflection of any horizontal track used in the construction of a hoist system shall not be more than 1 mm in every 200 mm of track length.

7.2.2 Test methods for specific safety requirements

7.2.2.1 The requirements of 7.2.1.1 shall be determined through functional test and verification of the manufacturer's installation instructions and by inspection.

7.2.2.2 The requirements of 7.2.1.2 shall be determined by measurement.

7.2.2.3 For hoists that are moved manually in a horizontal fashion, the hoist under load shall be driven into the end stop of the track 100 times at 1,5 m/s. For hoists that are moved with the use of motors the hoist will be driven into the end stop at the maximum linear velocity of the hoist.

7.2.2.4 The requirements of 7.2.1.4 shall be determined by rendering the normal limit switch inoperative and checking that the second device operates.

7.2.2.5 The requirements of 7.2.1.5 shall be determined through practical test and inspection.

7.2.2.6 When a track, installed in accordance with the manufacturer's instructions is loaded with the maximum load, the deflection between each set of fixings of the track shall be recorded in the test report.

7.3 Static strength (free-standing stationary hoists only)

7.3.1 Requirements for static strength (free-standing stationary hoists only)

After the static test as defined in 7.3.2, the hoist shall function as defined by the manufacturer. There shall be no deformation or wear that may affect its function.

7.3.2 Test methods for static strength (free-standing stationary hoists only)

The hoist and lifting devices shall be loaded statically according to the procedures and order described below.

The hoist shall be set in the most adverse position and placed on a 10° inclined surface and secured against tipping but not against deformation. The hoist shall then be loaded with 1,25 × maximum load for a period of 5 min in the most adverse condition.

The test is then performed with the surface horizontal and with 1,5 × maximum load for 20 min.

7.4 Static stability (free-standing stationary hoists only)

7.4.1 Requirements for static stability (free-standing stationary hoists only)

During the static stability test according to 7.4.2, both unloaded and under maximum load, the hoist shall not lose its equilibrium (balance) at the following angle:

— any direction 10°.

7.4.2 Test methods for static stability (free-standing stationary hoists only)

7.4.2.1 Positioning

7.4.2.1.1 General

The tests shall be carried out in the most adverse direction with the hoist in its most unstable position with regard to the position of the CSP and supporting structure.

7.4.2.1.2 Unloaded

Position the unloaded hoist on the test surface (see Figure 15).

Incline the test plane gradually until the hoist loses its equilibrium (balance). Record the angle of inclination.

Repeat the test in the other three directions.

7.4.2.1.3 Loaded

Attach the maximum load to the CSP in such a way that the load is able to move freely. Repeat the procedure as for the unloaded hoist.

For hoists with rigid body-support units, the centre of gravity of the load shall be placed in relation to the back rest according to Figure 3 but not more than:

— 350 mm from the front edge of the seat.

For stretchers, apply the loads as shown in Figures 4 a), 4 b) or 7.

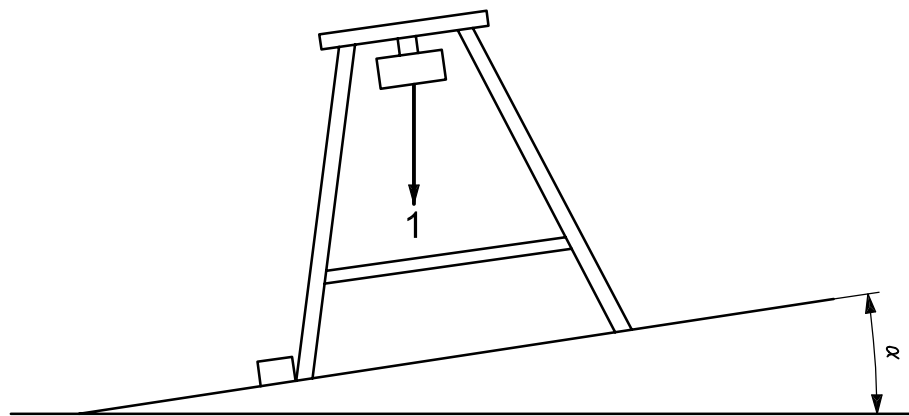

Key

1 test load

α stability angle = 10°

Figure 15 — Stability test for free-standing stationary hoists

7.5 Static strength for all other stationary hoists

7.5.1 Requirements for static strength for all other stationary hoists

After the static test according to 7.5.2, the hoist shall function as defined by the manufacturer.

There shall be no deformation or wear that may affect its function.

7.5.2 Test methods for static strength for all other stationary hoists

The hoist shall be fixed to a building structure in accordance with the manufacturer's instructions.

The hoist shall then be loaded with $1,5 \times$ maximum load for a period of 20 min.

7.6 Instructions for use

This subclause specifies requirements for stationary hoists in addition to those specified in 4.13.3.

The manufacturer shall provide the installer of the hoist with details of the loads being applied to the attachment points.

When a hoist is to be used by a disabled person living on their own, then some form of communication device shall be installed in the area of use of the hoist so that in the event of an emergency the disabled person is able to summon assistance.

NOTE This may, for example, be the fitting of an alarm system or the supply of a conveniently placed telephone, etc.

8 Non-rigid body-support units — Specific requirements and test methods

8.1 General requirements

This clause specifies requirements and test methods for non-rigid body-support units in addition to those specified in Clause 4.

After being tested according to 8.3, the body-support unit shall show no signs of damage or loss of function.

The unit shall be provided with an indication showing the types and design of spreader bar with which it may be used. This information may be given in the instructions for use.

8.2 Requirements for material and seams of the non-rigid body-support unit

8.2.1 If the material used in the construction of the body-support unit is claimed by the manufacturer to be flame-retardant, then the material shall not exhibit progressive ignition or flaming ignition when subjected to the test methods in EN 1021-1 and EN 1021-2.

NOTE There is guidance on other test methods in Annex A of EN 1021-1:1993 and EN 1021-2:1993.

8.2.2 When cleaned and/or disinfected according to the manufacturer's instructions, the body-support unit shall not shrink more than 5 % of its length and width.

8.3 Test methods for non-rigid body-support unit

If the body-support unit is designed to be laundered, it shall be cleaned and dried ten (10) times in accordance with the manufacturer's instructions and then tested with a static load of $1,5 \times$ the maximum load for 20 min.

After the test, it shall be subjected to an extensive inspection during which attention shall be given to all parts, i.e. fabric, seams, stitching, loops, loop fixations, and fabric at the positions in which rigid parts are received in the fabric. After the test, no part shall show any sign of damage or wear.

Any dimensional change shall be determined by measurement.

8.4 Information supplied by the manufacturer

8.4.1 Marking

This subclause specifies requirements for non-rigid body-support units in addition to those specified in 4.13.2.

The manufacturer shall provide the following information on a label that is permanently fixed to the body-support unit:

- the size of the body-support unit;
- a warning/attention mark which will refer the carer to the instructions for use of the hoist and/or body-support unit;

- marking to indicate if the body-support unit is designed only to be used on one dedicated type of spreader bar;
- an indication of the method by which the body-support unit shall be cleaned and/or disinfected; any symbols used shall comply with ISO 3758;

NOTE It may not be possible to include all of the following information on the body-support unit. It is suggested that any other information be given in the instructions for use.

- field of application, directions for use for each design of the body-support;
- the method of lifting, particularly the attitude, namely sitting, sitting/recumbent or recumbent, and also any other important information regarding choice of type, design and application method;
- if a body-support unit is unsuitable for a specific handicap (disability);
- a warning not to use a damaged or badly worn body-support unit.

8.4.2 Instructions for use

This subclause specifies requirements in addition to those specified in 4.13.3.

The manufacturer shall provide details regarding:

- the materials used in the manufacture of the body-support unit;
- the method by which the body-support unit can be adjusted or removed.

A statement shall be included warning the user that a risk assessment shall be carried out to ensure that the correct size, type and shape of body-support unit is being used for the patient.

9 Rigid body-support units — Specific requirements and test methods

9.1 General requirements

This clause specifies requirements and test methods for rigid body-support units in addition to those specified in Clause 4.

Should the body-support unit not be permanently attached to the hoist, then the design shall prevent inadvertent detachment. If the material used in the construction of the body-support unit is claimed to be flame-retardant by the manufacturer, then the material shall not exhibit progressive ignition or flaming ignition when subjected to the test methods in EN 1021-1 and EN 1021-2.

NOTE There is guidance on other test methods in the Annex A of EN 1021-1:1993 and EN 1021-2:1993.

9.2 Requirements for backrest

The angle between the sitting part and the backrest shall be not less than 90°.

9.3 Requirements and test methods for durability

The rigid body-support unit, in combination with the hoist, shall be subjected to the same tests as for the complete lifting-device.

The locking system of detachable body-support units shall be function tested for at least 1 000 cycles.

After the durability tests, the rigid body-support unit and the locking system shall still function as specified by the manufacturer.

9.4 Information supplied by the manufacturer

9.4.1 Marking

This subclause specifies requirements for rigid body-support units in addition to those specified in 4.13.2.

The manufacturer shall provide the following information on a label that is permanently fixed to the body-support unit:

- a warning/attention mark which will refer the carer to the instructions for use of the hoist and/or body-support unit;
- marking to indicate if the body-support unit is designed only to be used on one dedicated type of hoist;
- an indication of the method by which the body-support unit shall be cleaned and/or disinfected; any symbols used shall comply with ISO 3758;

NOTE It may not be possible to include all of the following information on the body-support unit. It is suggested that any other information be given in the instructions for use.

- field of application, directions for use for each design of the body-support unit;
- the method of lifting, particularly the attitude, namely sitting, sitting/recumbent or recumbent, but also other important information regarding choice of type, design and application method;
- if a body-support unit is unsuitable for a specific handicap (disability);
- a warning not to use a damaged or badly worn body-support unit;
- the size of the body-support unit if applicable.

9.4.2 Instructions for use

This subclause specifies requirements in addition to those specified in 4.13.3.

The manufacturer shall provide details regarding:

- the materials used in the manufacture of the body-support unit;
- the method by which the body-support unit can be adjusted or removed;
- the sizes of the body-support unit if applicable;

A statement shall be included warning the user that a risk assessment shall be carried out to ensure that the correct size, type and shape of body-support unit is being used for the patient.

10 Bathtub hoists — Specific requirements and test methods

10.1 General requirements

10.1.1 General

This clause specifies requirements and test methods for bathtub hoists. Therefore, unless specifically stated, bathtub hoists shall not fulfill the requirements in Clause 4 and Clause 7 as the applicable requirements have been included in the present clause.

For the purposes of this section of this International Standard, it is necessary to create a reference point. This shall be the point on the front edge of the body-support unit measured halfway across the width of the said body-support unit (see Figure 8).

10.1.2 Risk analysis

The requirement of 4.1.1 shall apply.

10.1.3 Ergonomic factors

10.1.3.1 The requirements of 4.1.2 shall apply.

10.1.3.2 If the hoist or a part of the hoist has a mass of more than 20 kg and is intended by the manufacturer to be portable, then the hoist shall either be provided with suitable handling devices (e.g. handles, lifting eyes) placed to enable the hoist to be carried by two or more persons, or the manufacturer's information shall indicate the points where the hoist can be lifted safely and describe how it shall be handled during lifting, assembly and/or carrying. If practical, the component parts shall be labelled to indicate where the aid can be lifted safely and/or how it shall be handled during lifting, assembly and/or carrying.

10.1.3.3 The maximum weight of a complete bathtub hoist shall be indicated on a label that shall be placed in a prominent position.

If the bathtub hoist is able to be split into a number of parts, and any one of those parts weighs more than 20 kg, then the maximum weight of each part over 20 kg shall be indicated on those parts.

10.1.4 Noise

The requirements of 4.1.3 shall apply.

10.2 General test methods

10.2.1 Test conditions

The requirements of 4.2.1 shall apply.

10.2.2 Test equipment

10.2.2.1 The requirements of 4.2.2.1 and 4.2.2.2 shall apply.

10.2.2.2 Test load: for the purposes of this subclause, this shall take the form of a load that is able to simulate the loads as applied by the human body.

NOTE See Figures 3, 4 a) and 4 b) for positioning of the loads.

10.2.2.3 The requirements of 4.2.2.4 to 4.2.2.7 shall apply.

10.2.2.4 The requirements of 4.2.2.8 shall not apply.

10.2.2.5 The requirements of 4.2.2.9 shall apply.

10.2.3 Permissible errors of test equipment

The requirements of 4.2.3 shall apply.

10.2.4 Test report

The requirements of 4.2.4 shall apply.

10.3 Safety requirements

10.3.1 General safety requirements

10.3.1.1 Unless specifically designed to do otherwise, every bathtub hoist shall be capable of lifting a person of 120 kg mass excluding the mass of any body-support unit.

10.3.1.2 The requirements of 4.3.1.2 to 4.3.1.16 shall apply.

10.3.1.3 The manufacturer shall inform the user of the potential risks associated with overloading the hoist. This can take the form of labels and/or in the instructions for use.

When a hoist is to be used by a disabled person on their own then it is necessary to ensure that, in the event of a failure of the hoist, the disabled person is not left in a potentially dangerous situation.

NOTE This may, for example, take the form of a warning in the instructions for use, the fitting of an alarm system or the supply of a conveniently placed telephone, etc.

10.3.1.4 The requirements of 4.3.1.17 to 4.3.1.24 shall apply.

10.3.2 Test methods for general safety requirements

10.3.2.1 The requirements described in 10.3.1.1 shall be confirmed through practical test and inspection.

10.3.2.2 The test methods of 4.3.2.1 to 4.3.2.24 shall apply.

10.3.2.3 The requirements described in 10.3.1.3. shall be confirmed through inspection.

10.4 Body-support units

The requirements and test methods of 4.4 shall apply.

10.5 Spreader bar

The requirements and test methods of 4.6 shall apply.

10.6 Performance

The requirements and test methods of 4.7 shall apply.

10.7 Rate (velocity) of lifting and lowering

The requirements and test methods of 4.8 shall apply.

10.8 Operating forces

The requirements and test methods of 4.9 shall apply.

10.9 Durability

10.9.1 Requirements for durability

After testing in accordance with the requirements of 10.9.2, the hoist shall function as intended with the maximum load and shall show no signs of permanent deformation or wear that may affect its function.

10.9.2 Test methods for durability

10.9.2.1 The hoist shall be fixed/mounted as specified by the manufacturer and/or placed in the most adverse condition on the test surface as specified in 4.2.2.1 or in accordance with the manufacturer's installation instructions. The hoist shall be tested in the most adverse position regarding the body-support unit.

10.9.2.2 The working:pause ratio (duty cycle) during test shall be 15:85 if not otherwise stated by the manufacturer. If the hoist is intended to be operated at varying speeds, then the durability test will be performed using the speed that represents the most adverse condition as stated by the manufacturer.

10.9.2.3 If necessary, it is permissible to use an alternative power supply instead of the battery for the purpose of durability test only, as agreed with the manufacturer of the hoist.

10.9.2.4 Maintenance during testing shall only be carried out if specifically required by the manufacturer in his service manual.

10.9.2.5 Position the load on the hoist as shown in Figures 3, 4 a) and 4 b). Raise and lower the hoist through one complete lifting cycle.

10.9.2.6 Repeat the lifting cycle of the hoist for a total of 11 000 lifting cycles, according to the following schedule, and conduct the tests in the order shown:

- a) raise and lower the CSP of the hoist at its maximum velocity with no load for 1 000 cycles ensuring that the top and bottom limiting devices are activated;
- b) 10 000 lifting cycles with the maximum load; for electrical hoists, activate the lower end limiting device for approximately of 1 s in every lifting cycle.

10.10 Static strength and stability

10.10.1 Requirements for static strength and stability

10.10.1.1 After the static test as defined in 10.10.2.1, the hoist shall function as defined by the manufacturer. There shall be no deformation or wear that may affect its function.

10.10.1.2 Maximum deflection of any horizontal track used in the construction of a hoist system shall not be more than 1 mm in every 200 mm of track length.

The requirements do not apply to bathtub hoists that are placed in or mounted on a bathtub.

10.10.1.3 After the static test as described in 10.10.2.3, the hoist shall function as defined by the manufacturer. There shall be no deformation or wear that may affect its function.

10.10.2 Test methods for static strength and stability

10.10.2.1 The hoist and lifting devices shall be loaded statically according to the procedures and order described below.

The hoist shall be mounted as specified by the manufacturer and/or placed in the most adverse condition on the test surface as specified in 4.2.2.1 or in accordance with the manufacturer's installation instructions.

The hoist shall be tested in the most adverse position regarding the body-support unit.

The hoist shall then be loaded with $1,25 \times$ maximum load and the hoist on the plate or test bath tilted for 5 min in the following directions:

— 5° forwards, backwards and sideways.

The test is then performed with the plate or test bath horizontal and with $1,5 \times$ maximum load for 20 min.

10.10.2.2 If applicable for the hoist, a test sample of a track, installed in accordance with the manufacturer's instructions (but with a minimum of two fixings), is put under maximum load. Deflection between each set of fixings of the track shall be recorded in the test report.

10.10.2.3 If applicable, the hoist shall be fixed to a typical building structure in accordance with the manufacturer's instructions. The hoist shall then be loaded with $1,5 \times$ maximum load for a period of 20 min.

10.11 Hydraulic components

The requirements and test methods of 4.11 shall apply.

10.12 Pneumatic components

The requirements and test methods of 4.12 shall apply.

10.13 Specific safety requirements

10.13.1 Requirements for specific safety requirements

If a hoist is able to produce powered horizontal movement, then its linear velocity shall be limited to 0,3 m/s.

When a hoist is to be used by disabled persons on their own, it is necessary to ensure that, in the event of a failure of the hoist, the disabled person is not left in a potentially dangerous situation.

NOTE This may, for example, take the form of a warning in the instructions for use, the fitting of an alarm system or the supply of a conveniently placed telephone, etc.

10.13.2 Test methods for specific safety requirements

The requirements of 10.13.1 shall be determined by measurement.

10.14 Non-rigid body-support units

The requirements and test methods of Clause 8 shall apply.

10.15 Rigid body-support units — Requirements

The requirements and test methods of Clause 9 shall apply.

10.16 Information supplied by the manufacturer

10.16.1 General

The requirements of 4.13.1 shall apply.

10.16.2 Marking

The requirements of 4.13.2 shall apply.

In addition, the manufacturer shall provide relevant labelling indicating to the user the correct position(s) for lifting and handling the bathtub hoist (see 10.1.2). The manufacturer shall also provide relevant labelling to indicate the mass of each of the components in the event that any of those components has a mass in excess of 20 kg.

10.16.3 Instructions for use

The requirements of 4.13.3 shall apply.

Annex A (informative)

Structure of ISO 10535

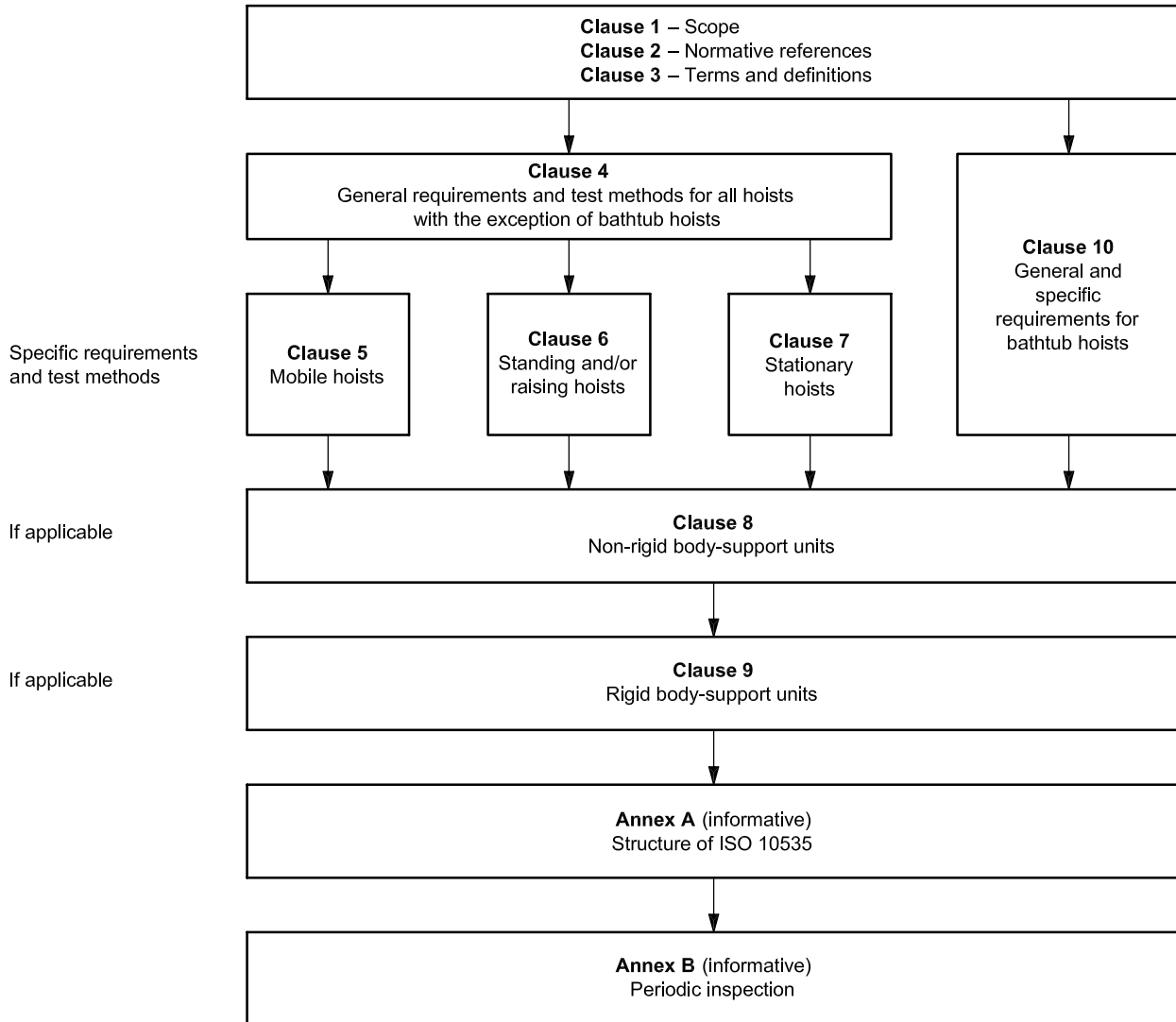

Annex B (informative)

Periodic inspection

B.1 Periodic inspection of the hoist should be undertaken at the time intervals stated by the manufacturer, but at least once a year. By periodic inspection is meant a visual examination (particularly of the hoist's load bearing structure and lifting mechanism with attachments, brakes, controls, safety devices and person-support devices) and whatever function tests and maintenance measures may be required, e.g. adjustment of brakes, tightening of fasteners.

Every inspection should include a working load test of one (1) lifting cycle with the maximum load.

B.2 Periodic inspection should be performed by a person who is suitably and properly qualified and well acquainted with the design, use and care of the hoist. The scope of the periodic inspection should be included in the instructions for use supplied with the hoist.

B.3 Any observations of importance for the safety of the hoist should be noted, preferably in a logbook which should be retained by the person(s) responsible for the servicing/maintenance of the hoist.

The date when corrective actions are taken, in response to noted observations, should also be noted in the logbook.

B.4 A record of the date of inspection of the hoist and inspection result should be noted in the logbook together with the signature of the inspector.

Any detachable rigid body-support units included in the inspection should be plainly marked for identification and noted in the logbook. The record shall include the situation of use (home or type of institution, etc.).

B.5 If periodic inspection reveals any defect, wear or other damage that jeopardizes the safety of the hoist, the owner should immediately be notified. In the event of immediate danger to safety, the hoist should immediately be taken out of service. It may then not be used until the deficiency has been eliminated.

B.6 Defects and damage of importance to the safety of the hoist which have occurred between inspections and have already led to corrective actions should be entered in the logbook.

B.7 Defects and damages should be reported back to the manufacturer for action. This feedback should be reported in the logbook.

B.8 Periodic inspection of the non-rigid body-support unit should be undertaken at the time intervals stated by the manufacturer, but at least every 6 months. More frequent inspections may be required where a non-rigid body-support unit is used or cleaned more frequently than normal.

B.9 Inspections should be performed by a person who is suitably and properly qualified and well acquainted with the design, use and care of the body-support unit.

The inspection should be to find signs of damage, wear or potential failure.

B.10 The inspection record should be retained safely for examination in the event of an incident.

B.11 The inspection record should include the following information:

- date of inspection;
- identification details and serial number of the body-support unit;
- information about the condition of the body-support unit;
- date next inspection is due;
- identification and signature of the inspector.

NATIONAL ANNEX A
([National Foreword](#))

A-1 BIS CERTIFICATION MARKING

The product(s) conforming to the requirements of this standard may be certified as per the conformity assessment schemes under the provisions of the *Bureau of Indian Standards Act, 2016* and the Rules and Regulations framed thereunder, and the product(s) may be marked with the Standard Mark.

Bureau of Indian Standards

BIS is a statutory institution established under the *Bureau of Indian Standards Act, 2016* to promote harmonious development of the activities of standardization, marking and quality certification of goods and attending to connected matters in the country.

Copyright

BIS has the copyright of all its publications. No part of these publications may be reproduced in any form without the prior permission in writing of BIS. This does not preclude the free use, in the course of implementing the standard, of necessary details, such as symbols and sizes, type or grade designations. Enquiries relating to copyright be addressed to the Head (Publication & Sales), BIS.

Review of Indian Standards

Amendments are issued to standards as the need arises on the basis of comments. Standards are also reviewed periodically; a standard along with amendments is reaffirmed when such review indicates that no changes are needed; if the review indicates that changes are needed, it is taken up for revision. Users of Indian Standards should ascertain that they are in possession of the latest amendments or edition by referring to the website-www.bis.gov.in or www.standardsbis.in.

This Indian Standard has been developed from Doc No.: MHD 09 (24109).

Amendments Issued Since Publication

Amend No.	Date of Issue	Text Affected

BUREAU OF INDIAN STANDARDS

Headquarters:

Manak Bhavan, 9 Bahadur Shah Zafar Marg, New Delhi 110002

Telephones: 2323 0131, 2323 3375, 2323 9402

Website: www.bis.gov.in

Regional Offices:

Central : 601/A, Konnectus Tower -1, 6th Floor,
DMRC Building, Bhavbhuti Marg, New
Delhi 110002

Telephones

{ 2323 7617

Eastern : 8th Floor, Plot No 7/7 & 7/8, CP Block, Sector V,
Salt Lake, Kolkata, West Bengal 700091

{ 2367 0012
2320 9474

Northern : Plot No. 4-A, Sector 27-B, Madhya Marg,
Chandigarh 160019

{ 265 9930

Southern : C.I.T. Campus, IV Cross Road, Taramani, Chennai 600113

{ 2254 1442
2254 1216

Western : Manakalya, 5th Floor/MTNL CETTM, Technology Street, Hiranandani Gardens, Powai
Mumbai 400076

{ 25700030
25702715

Branches : AHMEDABAD, BENGALURU, BHOPAL, BHUBANESHWAR, CHANDIGARH, CHENNAI, COIMBATORE, DEHRADUN, DELHI, FARIDABAD, GHAZIABAD, GUWAHATI, HARYANA (CHANDIGARH), HUBLI, HYDERABAD, JAIPUR, JAMMU, JAMSHEDPUR, KOCHI, KOLKATA, LUCKNOW, MADURAI, MUMBAI, NAGPUR, NOIDA, PARWANOO, PATNA, PUNE, RAIPUR, RAJKOT, SURAT, VIJAYAWADA.