

भारतीय मानक
Indian Standard

IS 18879 (Part 15) : 2024
ISO 8536-15 : 2022
+Amd 1 : 2023

चिकित्सीय उपयोग के लिए इन्फ्यूजन उपकरण

भाग 15 एकल उपयोग के लिए प्रकाश-सुरक्षात्मक
इन्फ्यूजन सेट्स

Infusion Equipment for Medical Use Part 15 Light-Protective Infusion Sets for Single Use

ICS 11.040.20

© BIS 2024

© ISO 2022



भारतीय मानक ब्यूरो
BUREAU OF INDIAN STANDARDS
मानक भवन, 9 बहादुर शाह ज़फर मार्ग, नई दिल्ली - 110002
MANAK BHAVAN, 9 BAHADUR SHAH ZAFAR MARG
NEW DELHI - 110002
www.bis.gov.in www.standardsbis.in

September 2024

Price Group 7

NATIONAL FOREWORD

This Indian Standard (Part 15) which is identical to ISO 8536-15 : 2022 'Infusion equipment for medical use — Part 15: Light-protective infusion sets for single use' issued by the International Organization for Standardization (ISO) was adopted by the Bureau of Indian Standards on the recommendation of the Hospital Equipment and Surgical Disposable Products Sectional Committee and after approval of the Medical Equipment and Hospital Planning Division Council.

This Indian Standard is published in fifteen parts. The other parts in this series are:

Part 1 Infusion glass bottles

Part 2 Closures for infusion bottles

Part 3 Aluminium caps for infusion bottles

Part 4 Infusion sets for single use, gravity feed

Part 5 Burette infusion sets for single use, gravity feed

Part 6 Freeze drying closures for infusion bottles

Part 7 Caps made of aluminium-plastics combinations for infusion bottles

Part 8 Infusion sets for single use with pressure infusion apparatus

Part 9 Fluid lines for single use with pressure infusion equipment

Part 10 Accessories for fluid lines for single use with pressure infusion equipment

Part 11 Infusion filters for single use with pressure infusion equipment

Part 12 Check valves for single use

Part 13 Graduated flow regulators for single use with fluid contact

Part 14 Clamps and flow regulators for transfusion and infusion equipment without fluid contact

Amendment 1 published in 2023 to ISO 8536-15:2022 is given at the end of this publication.

The text of ISO standard has been approved as suitable for publication as an Indian Standard without deviations. Certain conventions are however not identical to those used in Indian Standards. Attention is particularly drawn to the following:

- a) Wherever the words 'International Standard' appear referring to this standard, they should be read as 'Indian Standard'; and
- b) Comma (,) has been used as a decimal marker while in Indian Standards, the current practice is to use a point (.) as the decimal marker.

In this adopted standard, reference appears to certain International Standards for which Indian Standards also exist. The corresponding Indian Standards which are to be substituted in their respective places are listed below along with their degree of equivalence for the editions indicated:

<i>International Standard</i>	<i>Corresponding Indian Standard</i>	<i>Degree of Equivalence</i>
ISO 8536-1, Infusion equipment for medical use — Part 1: Infusion glass bottles	IS/ISO 8536-1 : 2011 Infusion equipment for medical use: Part 1 Infusion glass bottles	Identical
ISO 8536-2, Infusion equipment for medical use — Part 2: Closures for infusion bottles	IS 18879 (Part 2) : 2024/ISO 8536-2 : 2023 Infusion equipment for medical use: Part 2 Closures for infusion bottles	Identical
ISO 8536-3, Infusion equipment for medical use — Part 3: Aluminium caps for infusion bottles	IS 18879 (Part 3) : 2024/ISO 8536-3 : 2009 Infusion equipment for medical use: Part 3 Aluminium caps for infusion bottles + AMD 1 : 2022	Identical
ISO 8536-4, Infusion equipment for medical use — Part 4: Infusion sets for single use, gravity feed	IS/ISO 8536-4 : 2019 Infusion equipment for medical use: Part 4 Infusion sets for single use, gravity feed	Identical
ISO 8536-5, Infusion equipment for medical use — Part 5: Burette infusion sets for single use, gravity feed	IS 18879 (Part 5) : 2024/ISO 8536-5 : 2004 Infusion equipment for medical use: Part 5 Burette infusion sets for single use gravity feed	Identical
ISO 8536-6, Infusion equipment for medical use — Part 6: Freeze drying closures for infusion bottles	IS 18879 (Part 6) : 2024/ISO 8536-6 : 2016 Infusion equipment for medical use: Part 6 Freeze drying closures for infusion bottles	Identical
ISO 8536-7, Infusion equipment for medical use — Part 7: Caps made of aluminium-plastics combinations for infusion bottles	IS 18879 (Part 7) : 2024/ISO 8536-7 : 2009 Infusion equipment for medical use: Part 7 Caps made of aluminium-plastics combinations for infusion bottles	Identical
ISO 8536-8, Infusion equipment for medical use — Part 8: Infusion sets for single use with pressure infusion apparatus	IS 18879 (Part 8) : 2024/ISO 8536-8 : 2015 Infusion equipment for medical use: Part 8 Infusion sets for single use with pressure infusion apparatus	Identical
ISO 8536-9, Infusion equipment for medical use — Part 9: Fluid lines for single use with pressure infusion equipment	IS 18879 (Part 9) : 2024/ISO 8536-9 : 2015 Infusion equipment for medical use: Part 9 Fluid lines for single use with pressure infusion equipment	Identical
ISO 8536-10, Infusion equipment for medical use — Part 10: Accessories for fluid lines for single use with pressure infusion equipment	IS 18879 (Part 10) : 2024/ISO 8536-10 : 2015 Infusion equipment for medical use: Part 10 Accessories for fluid lines for single use with pressure infusion equipment	Identical

<i>International Standard</i>	<i>Corresponding Indian Standard</i>	<i>Degree of Equivalence</i>
ISO 8536-11, Infusion equipment for medical use — Part 11: Infusion filters for single use with pressure infusion equipment	IS 18879 (Part 11) : 2024/ISO 8536-11 : 2015 Infusion equipment for medical use: Part 11 Infusion filters for single use with pressure infusion equipment	Identical
ISO 8536-12, Infusion equipment for medical use — Part 12: Check valves for single use	IS 18879 (Part 12) : 2024/ISO 8536-12 : 2021 Infusion equipment for medical use: Part 12 Check valves for single use	Identical
ISO 8536-13, Infusion equipment for medical use — Part 13: Graduated flow regulators for single use with fluid contact	IS 18879 (Part 13) : 2024/ISO 8536-13 : 2016 Infusion equipment for medical use: Part 13 Graduated flow regulators for single use with fluid contact	Identical
ISO 8536-14, Infusion equipment for medical use — Part 14: Clamps and flow regulators for transfusion and infusion equipment without fluid contact	IS 18879 (Part 14) : 2024/ISO 8536-14 : 2016 Infusion equipment for medical use: Part 14 Clamps and flow regulators for transfusion and infusion equipment without fluid contact	Identical

The Committee has reviewed the provisions of the following International Standards referred in this adopted standard and has decided that they are acceptable for use in conjunction with this standard:

<i>International Standard</i>	<i>Title</i>
GB/T 601-2016	Chemical reagent — Preparations of reference titration solutions

This standard also makes a reference to the BIS Certification Marking of the product, details of which is given in [National Annex A](#).

For the purpose of deciding whether a particular requirement of this standard is complied with, the final value, observed or calculated, expressing the result of a test shall be rounded off in accordance with IS 2 : 2022 'Rules for rounding off numerical values (*second revision*)'.

Contents

Page

Introduction	iv
1 Scope	1
2 Normative references	1
3 Terms and definitions	1
4 General requirements	1
5 Materials	1
6 Physical requirements	2
6.1 General.....	2
6.2 Transparency.....	2
6.3 Light-protective performance.....	2
6.4 Decolourization.....	2
7 Chemical requirements	2
8 Biological requirements	2
9 Labelling	3
10 Packaging	3
11 Disposal	3
Annex A (normative) Determination of light transmittance	4
Annex B (normative) Decolourization test – physical method	6
Annex C (normative) Chemical method for decolourization test – visual colorimetry	7
Bibliography	8
National Annex A	9

Introduction

With the continuous development of infusion technology and the increasingly exacting clinical requirements, some infusion sets need to be adapted to specific clinical requirements.

Some pharmaceuticals, such as sodium nitroprusside, nitroglycerin and vitamin B2, are light sensitive and need to be clinically infused under light-protective conditions; this document is applicable to such sets.

This document stipulates the light-transmission requirements for the drip chamber and the tube. Since other components are limited by their external dimensions, they are not subject to light-transmission requirements and whether they will be light-protective or not is at the manufacturer's discretion.

It is the responsibility of the device manufacturer to keep the light-protection of the infusion sets stable during the shelf life. [Annex A](#), [Annex B](#) and [Annex C](#) give the methods for evaluation of light-protective infusion sets.

Indian Standard

INFUSION EQUIPMENT FOR MEDICAL USE
PART 15 LIGHT-PROTECTIVE INFUSION SETS FOR SINGLE USE

1 Scope

This document specifies the requirements for infusion sets for single use that use light-protective agents in the fluid path materials (henceforth abbreviated as "light-protective infusion sets").

This document also provides guidelines for performance and quality specifications of materials used in light-protective infusion sets.

2 Normative references

The following documents are referred to in the text in such a way that some or all of their content constitutes requirements of this document. For dated references, only the edition cited applies. For undated references, the latest edition of the referenced document (including any amendments) applies.

GB/T 601-2016, *Chemical reagent — Preparations of reference titration solutions*

ISO 8536 (all parts), *Infusion equipment for medical use*

3 Terms and definitions

For the purposes of this document, the following terms and definitions apply.

ISO and IEC maintain terminology databases for use in standardization at the following addresses:

- ISO Online browsing platform: available at <https://www.iso.org/obp>
- IEC Electropedia: available at <https://www.electropedia.org/>

3.1

monograph

publication that specifies for a drug (or class of related drugs) the kinds and amounts of ingredients it can contain, the conditions and limitations for which it can be offered, directions for use, warnings, and other information required on its labelling

4 General requirements

Based on the infusion set used, the requirements of the corresponding part in the ISO 8536 series shall apply.

5 Materials

Light-protective infusion sets shall meet the physical requirements in [Clause 6](#). Materials of light-protective infusion sets shall meet the chemical and biological requirements in [Clause 7](#) and [Clause 8](#).

6 Physical requirements

6.1 General

The physical requirements for the light-protective infusion set shall conform to the physical requirements of the applicable part in the ISO 8536 series and the requirements given in [6.2](#) to [6.4](#).

6.2 Transparency

The tube, made of flexible material, shall be transparent or sufficiently translucent so that the interface of air and water during the passage of air bubbles can be observed with normal or corrected vision (see ISO 8536-4:2019, 7.6).

For infusion sets containing a drip chamber, the upper part of the drip chamber shall be transparent or sufficiently translucent to allow continuous observation of the droplets.

6.3 Light-protective performance

When tested in accordance with [Annex A](#), the light transmittance of the light-protective infusion set in the wavelength range from 290 nm to at least 450 nm shall conform to [Table 1](#).

NOTE 1 The specified wavelength range is in alignment with provisions in USP, Chapter 671. However, there might be pharmaceuticals requiring a broader spectrum.

Table 1 — Light transmittance limit of each component

Component	Light transmittance %
Drip chamber	≤35
Tube	≤15

NOTE 2 Components other than drip chambers and tubes, when considered relevant for the intended application based on the related risks, might require a different method of light transmission assessment that is not part of this document.

6.4 Decolourization

6.4.1 Testing of decolourization in addition to testing light transmittance and biocompatibility is to provide safety to the healthcare professional and the patient against the chemical agent that is used for light-protection.

6.4.2 Outer surfaces of light-protective infusion sets shall not decolourize. Test in accordance with [Annex B](#).

6.4.3 Inner surfaces of light-protective infusion sets shall not decolourize. Test in accordance with [Annex C](#).

7 Chemical requirements

The requirements of ISO 8536-4 shall apply.

8 Biological requirements

The requirements of ISO 8536-4 shall apply.

9 Labelling

The requirements of the applicable part in the ISO 8536 series shall apply.

In addition, light-protective sets shall be labelled "Light-protective set" or a relevant translation.

The labelling of light-protective infusion sets shall include the wavelength spectrum for which the transmittance rates fulfil the requirements of [Table 1](#).

The instructions for use shall include a generic statement regarding the risks related to the effect of length of infusion and room conditions (e.g. surrounding light intensity), referring to the pharmaceutical manufacturers' monograph.

10 Packaging

The requirements of ISO 8536-4 shall apply.

11 Disposal

Information for secure and environmentally sound disposal of light-protective infusion sets for single use should be given.

EXAMPLE "Always dispose of blood contaminated products in a manner consistent with established biohazard procedures."

Annex A (normative)

Determination of light transmittance

A.1 Principle

Use a spectrophotometer with appropriate sensitivity and accuracy suitable for measuring the light transmittance of transparent or translucent plastic materials. For transparent plastics, use a spectrophotometer with adequate sensitivity and accuracy to measure and record the amount of transmitted light. For translucent plastics, the above spectrophotometer should be used but with the added function of measuring the scattered light and parallel light of transmitted lights. Using air as a reference, the light transmittance in the wavelength range from 290 nm to at least 450 nm will be measured.

A.2 Apparatus

A.2.1 Spectrophotometer, which can scan in the range of 290 nm to at least 450 nm.

A.2.2 Sample holder, as shown in [Figure A.1](#). The surface should be smooth without burrs, and the shape and size should be suitable for vertical placement in the colorimetric pool of the spectrophotometer.

A.3 Preparation of the sample

Use suitable tools to cut open the drip chamber and tube of the light-protective infusion set. The representative part with an average wall thickness is selected and trimmed into suitable flaky shape so as to be installed in the sample holder. After cutting, wash and dry them, avoiding surface abrasion. If the sample is too small to cover the optical port of the sample holder, use an appropriate piece of paper or strip to cover the uncovered part. The length of the sample shall be larger than the length of the slit. After putting the sample into the holder, gently wipe it with lens paper to avoid leaving fingerprints or other stains where light passes through.

A.4 Test procedure

Place the sample holder in the spectrophotometer (with the concave side facing the light source). Try to place the axis of the sample in the centre of the slit and make it parallel to the slit. The sample light beam shall pass through the sample surface normally and the reflection loss of the beam shall be minimized.

Taking the air as reference, measure the light transmittance at the continuous wavelengths in the range of 290 nm to at least 450 nm of the sample.

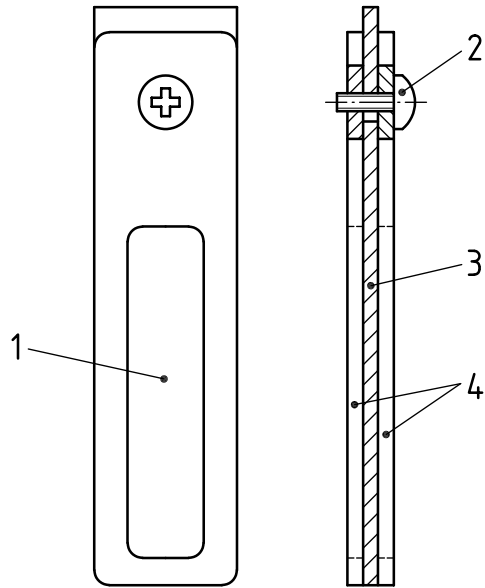

Key

- 1 optical port
- 2 clamping screw
- 3 flattened sample
- 4 holding plate

Figure A.1 — Sample holder

Annex B **(normative)**

Decolourization test – physical method

B.1 Principle

Expose the light-protective infusion set to high temperature to speed up colour precipitation rate, and then wipe it with absorbent cotton to observe the decolourization.

B.2 Test procedure

B.2.1 Expose the light-protective infusion set to a temperature of (60 ± 5) °C for 24 h. After that, let the light-protective infusion set cool to (23 ± 2) °C before use. The light-protective infusion set shall be kept clean.

B.2.2 Uncoil the light-protective infusion set and take a sufficient piece of absorbent cotton (consider the dimensions of the sample) to wrap a section of the fluid path. Pinch the test part with fingers; the force should be adequate to make the inner walls of the tube contact. Pull the absorbent cotton along the fluid path in one direction for 1 m (including the drip chamber), and then pull it in the reverse direction for 1 m, after which open the absorbent cotton for observation.

B.3 Interpretation of results

If no obvious staining is found on the absorbent cotton, it can be evaluated as "non-decolourizing".

Annex C (normative)

Chemical method for decolourization test – visual colorimetry

C.1 General

The chemical method for decolourization absorbance test utilizes four different solutions for a 2 h cyclic test.

C.2 Solution preparation

C.2.1 $c(\text{HCl}) = 0,1$ mol/l hydrochloric acid solution: 1 000 ml shall be prepared in accordance with GB/T 601-2016, 4.2.

C.2.2 $c(\text{NaOH}) = 0,1$ mol/l sodium hydroxide solution: 4,0 g sodium hydroxide shall be diluted with water to 1 000 ml.

C.2.3 Ethanol ($\text{CH}_3\text{CH}_2\text{OH}$) aqueous solution: 650 ml of anhydrous ethanol shall be diluted with water to 1 000 ml.

C.2.4 Polyethylene glycol 400 aqueous solution: 500 ml polyethylene glycol 400 shall be diluted with water to 1 000 ml.

C.3 Preparation of extract and blank liquids

Three sterile light-protective infusion sets and a 300 ml silicon boron glass flask shall be assembled into a closed circulation system. The flask shall be placed on a heater so that the temperature of the liquid in the flask is maintained at (37 ± 1) °C. The solution for extraction (250 ml) given in [C.2](#) shall be added and circulated for 2 h at a rate of approximately 1 l/h. Use, for example, a peristaltic pump to act on a silicone tube that shall be as short as possible and collect all the liquid. Cool the liquid and get the extraction.

Using the same leach solution, prepare the blank liquid with the same method without an infusion set.

C.4 Test procedure

Put 50 ml of the leach solution into the corresponding Nash colorimetric tube. Take another Nash colorimetric tube of 50 ml and put 50 ml of corresponding blank solution into it. Observe them from above against a white background and compare the colours.

C.5 Interpretation of results

If the colour of the leach solution is darker than the blank solution, the test infusion set fails the decolourization test.

Bibliography

- [1] USP UNITED STATES PHARMACOPEIA, <http://www.usp.org>

NATIONAL ANNEX A
([National Foreword](#))

A-1 BIS CERTIFICATION MARKING

The product(s) conforming to the requirements of this standard may be certified as per the conformity assessment schemes under the provisions of the *Bureau of Indian Standards Act, 2016* and the Rules and Regulations framed thereunder, and the product(s) may be marked with the Standard Mark.

AMENDMENT 1

Normative references

Add the following references:

ISO 10993-17, *Biological evaluation of medical devices — Part 17: Establishment of allowable limits for leachable substances*

ISO 10993-18, *Biological evaluation of medical devices — Part 18: Chemical characterization of medical device materials within a risk management process*

6.4.3

Replace the text with the following:

Inner surfaces of light-protective infusion sets shall not decolourize. Test in accordance with Annex C or, alternatively, test in accordance with ISO 10993-18 and risk assess in accordance with ISO 10993-17.

Bibliography

Replace entry [1] with the following:

[1] USP UNITED STATES PHARMACOPEIA, Chapter 671, <https://www.usp.org>

Bureau of Indian Standards

BIS is a statutory institution established under the *Bureau of Indian Standards Act, 2016* to promote harmonious development of the activities of standardization, marking and quality certification of goods and attending to connected matters in the country.

Copyright

BIS has the copyright of all its publications. No part of these publications may be reproduced in any form without the prior permission in writing of BIS. This does not preclude the free use, in the course of implementing the standard, of necessary details, such as symbols and sizes, type or grade designations. Enquiries relating to copyright be addressed to the Head (Publication & Sales), BIS.

Review of Indian Standards

Amendments are issued to standards as the need arises on the basis of comments. Standards are also reviewed periodically; a standard along with amendments is reaffirmed when such review indicates that no changes are needed; if the review indicates that changes are needed, it is taken up for revision. Users of Indian Standards should ascertain that they are in possession of the latest amendments or edition by referring to the website-www.bis.gov.in or www.standardsbis.in.

This Indian Standard has been developed from Doc No.: MHD 12 (25434).

Amendments Issued Since Publication

Amend No.	Date of Issue	Text Affected

BUREAU OF INDIAN STANDARDS

Headquarters:

Manak Bhavan, 9 Bahadur Shah Zafar Marg, New Delhi 110002

Telephones: 2323 0131, 2323 3375, 2323 9402

Website: www.bis.gov.in

Regional Offices:

Central : 601/A, Konnectus Tower -1, 6th Floor,
DMRC Building, Bhavbhuti Marg, New
Delhi 110002

Telephones

{ 2323 7617

Eastern : 8th Floor, Plot No 7/7 & 7/8, CP Block, Sector V,
Salt Lake, Kolkata, West Bengal 700091

{ 2367 0012
{ 2320 9474

Northern : Plot No. 4-A, Sector 27-B, Madhya Marg,
Chandigarh 160019

{ 265 9930

Southern : C.I.T. Campus, IV Cross Road, Taramani, Chennai 600113

{ 2254 1442
{ 2254 1216

Western : 5th Floor/MTNL CETTM, Technology Street, Hiranandani Gardens,
Powai, Mumbai 400076

{ 2570 0030
{ 2570 2715

Branches : AHMEDABAD, BENGALURU, BHOPAL, BHUBANESHWAR, CHANDIGARH, CHENNAI, COIMBATORE, DEHRADUN, DELHI, FARIDABAD, GHAZIABAD, GUWAHATI, HARYANA (CHANDIGARH), HUBLI, HYDERABAD, JAIPUR, JAMMU, JAMSHEDPUR, KOCHI, KOLKATA, LUCKNOW, MADURAI, MUMBAI, NAGPUR, NOIDA, PARWANOO, PATNA, PUNE, RAIPUR, RAJKOT, SURAT, VIJAYAWADA.