

डायलिसिस चेयर

Dialysis Chair

ICS 11.040.01

© BIS 2024



भारतीय मानक ब्यूरो
BUREAU OF INDIAN STANDARDS
मानक भवन, 9 बहादुर शाह ज़फर मार्ग, नई दिल्ली - 110002
MANAK BHAVAN, 9 BAHADUR SHAH ZAFAR MARG
NEW DELHI - 110002

www.bis.gov.in www.standardsbis.in

FOREWORD

This Indian Standard was adopted by the Bureau of Indian Standards after the draft finalized by the Hospital Equipment and Surgical Disposable Products Sectional Committee had been approved by the Medical Equipment and Hospital Planning Division Council.

Dialysis chairs are designed to assist and facilitate the work of physicians and medical staff in dialysis centers. It provides comfort to the patients during treatment. This chair can also be adjusted electrically to form a comfortable easy chair or a bed like couch. It requires less space than a conventional hospital bed.

The clauses [4.6](#) and [10](#) of this standard is depend upon the mutual agreement between supplier/manufacturer and purchaser.

The composition of the Committee responsible for formulation of this standard is given in [Annex B](#).

For the purpose of deciding whether a particular requirement of this standard is complied with the final value, observed or calculated, expressing the result of a test or analysis shall be rounded off in accordance with IS 2 : 2022 'Rules for rounding off numerical values (*second revision*)'. The number of significant places retained in the rounded off value should be same as that of the specified value in this standard.

Indian Standard

DIALYSIS CHAIR

1 SCOPE

1.1 This standard describes the requirements of dialysis chair used in dialysis centers and nephrology departments of hospitals for conducting dialysis procedure on patients.

1.2 The dialysis chair can be manually/Electrically operated.

2 REFERENCES

The standards listed in [Annex A](#) below contain provisions which, through reference in this text, constitute provisions of this standard. At the time of publication, the editions indicated were valid. All standards are subject to revision, and parties to agreements based on this standard are encouraged to investigate the possibility of applying the most recent edition of these standards.

3 COMPONENTS

3.1 The frame body material shall be made of powder coated mild steel to prevent rusting. The frame shall be provided with four non-skid lockable castors for easy movement of the dialysis chair.

3.2 Interwoven high grade leatherette as specified in IS 577 shall be used as upholstery for the dialysis chair.

3.3 Non-deformable soft Polyurethane (PU) foam shall be used in the dialysis chair to provide cushion and comfort to the patient.

4 CONSTRUCTIONAL REQUIREMENTS

4.1 The dialysis chair outer body shall have comfortable sitting for patient which should allow change in posture through smooth motorized movement in height, leg section and back section.

4.2 The dialysis chair shall have slide out lockable foot stool which allows the patient to step down from the chair safely.

4.3 The dialysis chair shall achieve flatbed position, sitting posture, trendelenburg position and Head-low position (with angle of minimum 10° to 12° angle). The recommended possible adjustments are as follows:

- a) Back rest tilt – 12° to 80°;
- b) Seat rest tilt – Same as specified; and

- c) Leg rest tilt – 80° to 12°; Leg position is essential for position during cramps of dialysis.

4.4 The dialysis chair shall have cleaning and disinfection facility for maintaining hygiene in accordance with IS 18742 (Part 1)/ISO 17664-1. It shall be resistant to liquid adsorption.

4.5 The seat cushion of the dialysis chair shall be removable. Both the broad arm rest of the chair shall be adjustable for height, vertical and horizontal position for achieving right hand position during dialysis.

4.6 Round Handle: The dialysis chair shall have a round handle for nurses to move the dialysis chair. The dialysis chair shall have 40 mm × 125 mm swivel castor with central brake.

4.7 The dialysis chair shall be able to quickly achieve head-low position in case of emergency with single touch button.

4.8 IV pole: For the convenience of nurses, the dialysis chair shall have an area to place the IV pole either at the front or the rear.

4.9 The dialysis chair shall have fold out tray arms for patients to place their belongings or rest their arms.

4.10 CPR legs: The dialysis chair shall have provision for CPR legs to support the CPR position.

4.11 The dialysis chair, if required by the purchaser, shall have PU non-skid lockable castors for stable position of patient allowing easy transfer of patient.

4.12 The dialysis chair shall have non-deformable foam of thickness between 60 mm to 100 mm for comfortable sitting for long time.

4.13 The dialysis chair, if required by the purchaser, shall have adjustable multi tray IV stand for keeping all dialysis related accessories.

4.14 The dialysis chair shall be suitable for a weight carrying capacity of upto 150 kg.

4.15 The dialysis chair shall be provided with a belt to support the patient during shifting.

4.16 The dialysis chair shall have provision to accommodate the portable food table.

4.17 The electrically operated dialysis chair shall have weight monitoring capability upto 200 kg.

4.18 The battery backup inside the electrically operated chair shall be as per IS 13450 (Part 1).

4.19 Hand Control: The electrically operated chair shall have two hand controls. One nurse operated hand control and one patient operated hand control. The patient individual hand control allows operation of the seat/footrest and backrest position for comfortable position during the procedure. The nursing staff should have control of Hi/Lo function only and this should be at the rear of the chair.

4.20 All exterior parts of the dialysis chair shall be capable of being cleaned and disinfected, using agents recommended by the manufacturer, without deteriorating the chair's surface and markings.

4.21 The upholstery and padding of the dialysis chair shall be flame resistant.

5 Environmental Factor

The dialysis chair shall be designed to withstand and capable of operating continuously in ambient temperature of 10 °C to 40 °C and relative humidity of 15 percent to 90 percent.

6 Electrical Safety and EMC Requirements (only for Electrically Operated Couches)

The electrically operated dialysis chair shall meet the specifications of IS 13450 (Part 1) and IS 13450 (Part 1/Sec 2).

6.1 The dialysis chair may have the provision for weight monitoring facility for immobilized patient.

7 WORKMANSHIP AND FINISH

7.1 The outer body of the dialysis chair shall be rust proof with long lasting performance.

7.2 The dialysis chair shall have round corner frame design and free from welding defects, sharp corners or any other protrusion/projections which may cause injury.

7.3 The upholstery should be resistant to water and conducive to the comfort of the patient seated for extended periods, and over periods in which temperature and humidity may change.

7.4 Controls, if provided for the adjustment of the seat and backrest, should be arranged and located so as to render their accidental actuation unlikely.

7.5 Moving parts that may constitute a hazard under normal working conditions should be protected or guarded to minimize the risk of injury to the operator or other personnel and occupant of the chair.

8 SHAPE AND DIMENSION

8.1 The typical shape may be as given in [Fig. 1](#).

8.2 Recommended dimensions of various basic parts of the chair shall be as follows:

8.2.1 Back seat height should be between 1 300 mm to 1 500 mm.

8.2.2 Cushion should be approximately 600 mm × 500 mm in size.

8.2.3 Reclining total length should be between 1 880 mm to 1 900 mm.

8.2.4 Back cushion length should be approximately 500 mm.

8.2.5 Reclined heights at each end should be 650 mm and 800 mm.

8.2.6 Headrest should be 400 mm (height) × 400 mm (top)/500 bottom width approximately.

8.2.7 Full chair width should be 900 mm approximately.

8.2.8 Cushioned arm rest should be of 500 mm (length) × 200 mm (width).

8.2.9 Reclined base to floor height should range from 500 mm and up to 700 mm.

8.2.10 Overall dimension of frame shall not exceed 1 000 mm (length) × 750 mm (width).

8.2.11 Leg support should be of 400 mm (height) × 500 mm (width)/250 mm (bottom).

NOTE — The above dimensions are only for guidance. Other dimensions as agreed between manufacturer and purchaser are also permitted, subject to compliance to other requirements of this Standard.

8.3 Tolerances on dimensions shall be ± 10 percent on declared values.

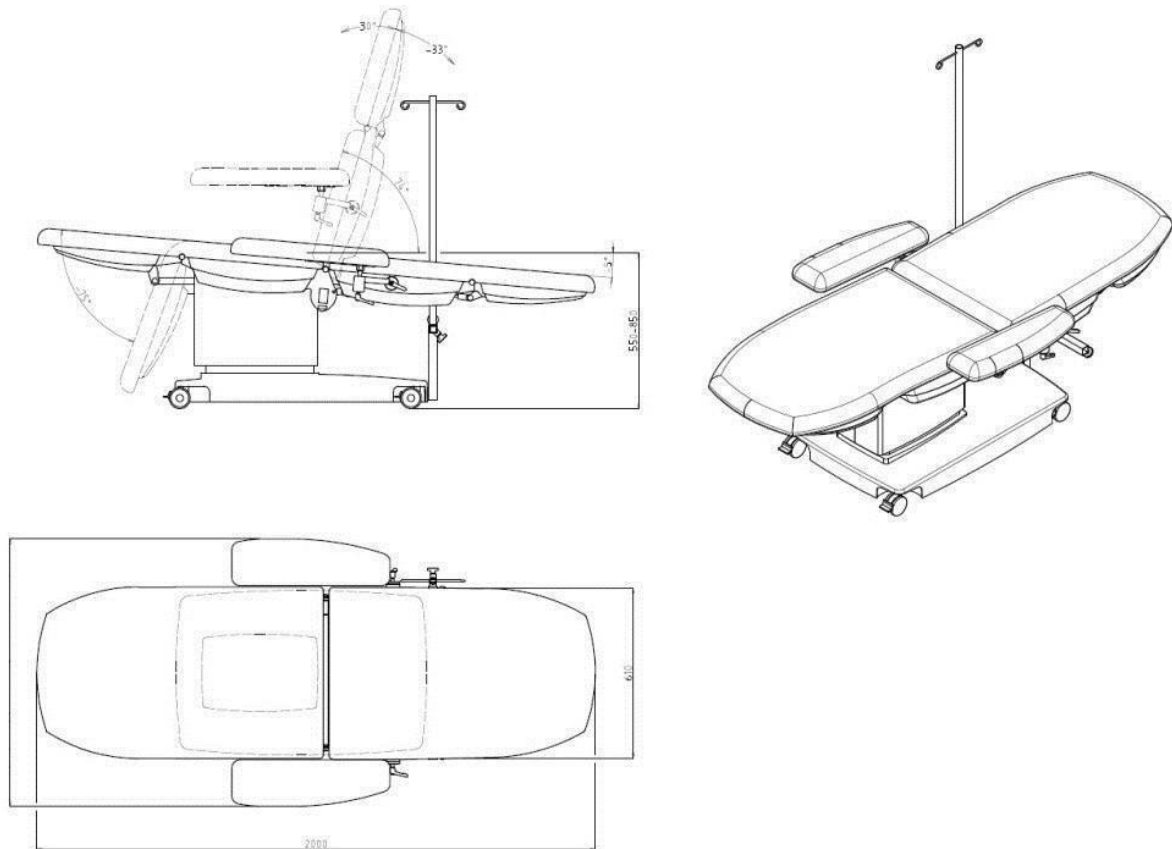

FIG. 1 GENERALIZED DIAGRAM FOR A TYPICAL DIALYSIS CHAIR

NOTE — The diagram shown above in [Fig. 1](#) is only for representation purpose, design of the chair shown here is for illustrative purpose only.

9 TESTS

9.1 The dialysis chair shall be subjected to tests in accordance with the requirements of relevant specifications.

9.2 Visual inspection shall be performed at normal visual.

9.3 Adhesion Test

For the painted portion of the dialysis chair, adhesion test is carried out. A square measuring (12 mm to 15 mm) shall be marked over conveniently selected spot on the painted portion and cross lines, at a distance of 1 mm to 1.5 mm apart and inclined at 120° , shall be inscribed over the marked portion with a pointed instrument. Thereafter, cello-tape shall be rubbed down over this portion and left for two minutes; after which it shall be jerked free from the painted surface. If more than 5 percent of the squares had ripped away from the painted surface and are adhering to the cello-tape, the portion shall be repainted and again subjected to this test now at two conveniently selected spots and the item considered passing only if it satisfies in both the cases.

9.4 Corrosion resistance Test

The coated/plated components shall be sufficiently corrosion resistant and pore-free to pass the appropriate test specified in IS 1068 or IS 5528/ISO 9227 for the particular service condition number. The performance rating shall be determined in accordance with IS 6009 to each tested article representing the relative freedom from defects at which coating is penetrated, with resulting the corrosion of the basis metal.

9.5 Performance Test

When the chair is pushed over a level and even surface with load (load to be as laid down in relevant specifications), it shall not wobble or rattle. It shall also move freely when pulled in circular motion and the castors shall face in the same direction without normal force.

9.6 Maneuverability Test

The chair shall be operated at moderate speed and shall turn and steer without difficulty of operation, structural or component failure.

9.7 Stability Test

The chair shall be tested for static load test in reclined position as well as in vertical seating position. It shall be loaded with sand bags weights totaling up to 300 kg load. It shall be subjected for this load for not less than 15 min. There shall be no damage or permanent set after the test. The chair shall operate normally after removal of the load.

9.8 Flammability

Testing for shall be carried out in accordance with IS 12467 (Part 1) and IS 12467 (Part 2).

9.9 Cleaning and Disinfection Mechanism

The dialysis chair shall have cleaning and disinfection facility for maintaining hygiene in accordance with mIS 18742 (Part 1)/ISO 17664-1.

9.10 The Essential principles of safety and performance of medical devices to be complied as per IS/ISO 16142- 1.

10 MANUFACTURER'S INSTRUCTIONS FOR USE

10.1 The manufacturer shall supply instructions for the safe operation and use of the dialysis chair. The instructions shall include step-by-step procedures for operating and maintaining the chair, with illustrations showing the location of the controls, together with explanations of their use.

10.2 The instructions for use shall also include the following information:

- a) Range of adjustment of seat height;
- b) Seat depth;
- c) Seat width;
- d) Range of backrest adjustment;
- e) Recommendations for cleaning and disinfecting agents, together with instructions for their use;

- f) Precautions regarding safe use of chair;
- g) Programming instructions in the electrically operated chair with a maximum of three positions programmed into the memory; and
- h) Recalibration: if there is loss of feedback from the actuators, a position lost beep sounds and recalibration can be done via the Nurse's control.

11 MARKING

11.1 The body of dialysis chair shall be indelibly and clearly marked with:

- a) Manufacturer's name or trademark;
- b) Model;
- c) Unique device identification number
- d) Read instructions before use

11.2 The packages shall also be marked with make or manufacture's trade-mark.

11.3 BIS Certificate Marking

The product(s) conforming to the requirements of this standard may be certified as per the conformity assessment schemes under the provisions of the *Bureau of Indian Standards Act, 2016* and the Rules and Regulations framed thereunder, and the product(s) may be marked with the Standard Mark.

12 PACKAGING

The dialysis chair shall be packaged for transportation in such a way that no damage can occur during anticipated transport conditions. The packaging shall be marked with 'Handling Instructions' on the outside of the package to facilitate handling/assembly and installation of the chair. The packaging shall be as agreed to between the purchaser and the manufacturer/supplier.

ANNEX A

(Clause 2)

LIST OF REFERRED STANDARDS

<i>IS No.</i>	<i>Title</i>	<i>IS No.</i>	<i>Title</i>
IS 577 : 1986	Specification for upholstery leather (<i>first revision</i>)	IS 3450 (Part 1) : 2024	Medical electrical equipment: Part 1 General requirements for basic safety and essential performance (IEC 60601-1 : 2020, MOD) (<i>third revision</i>)
IS 1068 : 1993	Electroplated coatings of nickel plus chromium and copper plus nickel plus chromium — Specification (<i>third revision</i>)	IS 13450 (Part 1/ Sec 2) : 2024	Medical electrical equipment: Part 1 General requirements for basic safety and essential performance, Section 2 Electromagnetic disturbances — Requirements and tests (IEC 60601-1-2 : 2020, MOD) (<i>second revision</i>)
IS 2039 (Part 1 to 3) : 1991	Steel tubes for bicycle and cycle rickshaws — Specification (<i>second revision</i>)	IS/ISO 16142-1 : 2016	Medical Devices — Recognized essential principles of safety and performance of medical devices: Part 1 General essential principles and additional specific essential principles for all Non-IVD medical devices and guidance on the selection of standards
IS 5528 : 2024/ ISO 9227 : 2022	Corrosion tests in artificial atmospheres — Salt spray tests (<i>second revision</i>)	IS 18742 (Part 1) : 2024/ISO 17664-1 : 2021	Processing of health care products — Information to be provided by the medical device manufacturer for the processing of medical devices Part 1 Critical and semi-critical medical devices
IS 6009 : 2024	Evaluation of Results of Accelerated Corrosion Test — Method (First Revision)		
IS 12467	Textiles — Assessment of the ignitability of upholstered furniture:		
(Part 1) : 2006	Ignition source: Smouldering cigarette (<i>first revision</i>)		
(Part 2) : 2006	Ignition source: Match flame equivalent (<i>first revision</i>)		

To access Indian Standards click on the link below:

https://www.services.bis.gov.in/php/BIS_2.0/bisconnect/knowyourstandards/Indian_standards/isdetails/

ANNEX B

(Foreword)

COMMITTEE COMPOSITION

Hospital Equipment and Surgical Disposable Products Sectional Committee, MHD 12

<i>Organization</i>	<i>Representative(s)</i>
In Personal Capacity, (AIIMS Vijaypur - 184120)	LT GEN SUNIL KANT (Chairperson)
3M India Limited, Bengaluru	DR PRABHA HEGDE MS KAVITHA KULKARNI (<i>Alternate</i>)
Asia Pacific Medical Technology Association (APACMed), Gurugram	SHRI R. ASHOK KUMAR SHRI PARVEEN JAIN (<i>Alternate</i>)
Association of Indian Medical Device Industry, New Delhi	SHRI RAVI ABRAHAM SHRI RAJIV NATH (<i>Alternate</i>)
B Braun Medical India Private Limited, New Delhi	SHRI VIVEK VEERBHAN MS ISHITA DHINGRA (<i>Alternate</i>)
B Medical Systems India Private Limited, New Delhi	SHRI KISHOR TUKARAM SHRI ANSHUMAN TULI (<i>Alternate</i>)
Boston Scientific India Private Limited, Gurugram	SHRI PRASHANTH PRABHAKAR SHRI DEV CHOPRA (<i>Alternate</i>)
Central Drugs Standard Control Organization, New Delhi	SHRI ASEEM SAHU MS SHYAMNI SASIDHARAN (<i>Alternate</i>)
Dupont, India 	SHRI VISHNU SHANKAR VYAS SHRI RAJDEEP SINGH GREWAL (<i>Alternate</i>)
Hindustan Syringes and Medical Devices Limited, Ballabgarh, Faridabad	SHRI PRAVEEN KUMAR SHARMA SHRI UPINDER VISHEN (<i>Alternate</i>)
Indian Rubber Gloves Manufacturers Association, New Delhi	SHRI MANMOHAN SINGH GULATI SHRI VIKAS ANAND (<i>Alternate</i>)
Johnson and Johnson Private Limited, Mumbai	SHRI HEMANT SONAWANE
Kalam Institute of Health Technology, Vishakhapatnam	SHRI AMIT SHARMA SHRI MOHAN RAGUL (<i>Alternate</i>)
Kanam Latex India Private Limited, Kottayam	SHRI ABRAHAM C. JACOB SHRI DONALD S. K. (<i>Alternate</i>)
Microtrol Sterilization Services Private Limited, Mumbai	SHRI BANSIDHAR S DHURANDHAR SHRI MANOJ MISHRA (<i>Alternate</i>)
National Institute of Health and Family Welfare, New Delhi	SHRI HITESH KUMAR SHRI SHIVLEY SAGEER (<i>Alternate</i>)

<i>Organization</i>	<i>Representative(s)</i>
Post Graduate Institute of Medical Education and Research, Chandigarh	DR NAVNEET DHALIWAL DR SHWETA TALATI (<i>Alternate I</i>) SHRI SANJEEV SHARMA (<i>Alternate II</i>)
Shriram Institute for Industrial Research, New Delhi	DR SANJAY RAJPUT MS MANISH RAWAT (<i>Alternate</i>)
Terumo Penpol Private Limited, Thiruvananthapuram	SHRI MANOJ A.
In Personal Capacity, (<i>Flat 315; Shelter Apt.; 15, Palm Grove Road; Victoria Layout - 560047</i>)	SHRI KULVEEN SINGH BALI
BIS Directorate General	SHRI CHINMAY DWIVEDI, SCIENTIST 'E' AND HEAD [(MEDICAL EQUIPMENT AND HOSPITAL PLANNING), (<i>Ex-officio</i>)]

Member Secretary

MS. UROOSA WARSI,
SCIENTIST 'C'/DEPUTY DIRECTOR
(MEDICAL EQUIPMENT AND HOSPITAL PLANNING), BIS

Bureau of Indian Standards

BIS is a statutory institution established under the *Bureau of Indian Standards Act, 2016* to promote harmonious development of the activities of standardization, marking and quality certification of goods and attending to connected matters in the country.

Copyright

BIS has the copyright of all its publications. No part of these publications may be reproduced in any form without the prior permission in writing of BIS. This does not preclude the free use, in the course of implementing the standard, of necessary details, such as symbols and sizes, type or grade designations. Enquiries relating to copyright be addressed to the Head (Publication & Sales), BIS.

Review of Indian Standards

Amendments are issued to standards as the need arises on the basis of comments. Standards are also reviewed periodically; a standard along with amendments is reaffirmed when such review indicates that no changes are needed; if the review indicates that changes are needed, it is taken up for revision. Users of Indian Standards should ascertain that they are in possession of the latest amendments or edition by referring to the website-www.bis.gov.in or www.standardsbis.in.

This Indian Standard has been developed from Doc No.: MHD 12 (19718).

Amendments Issued Since Publication

Amend No.	Date of Issue	Text Affected

BUREAU OF INDIAN STANDARDS

Headquarters:

Manak Bhavan, 9 Bahadur Shah Zafar Marg, New Delhi 110002

Telephones: 2323 0131, 2323 3375, 2323 9402

Website: www.bis.gov.in

Regional Offices:

	Telephones
Central : 601/A, Konnectus Tower -1, 6 th Floor, DMRC Building, Bhavbhuti Marg, New Delhi 110002	{ 2323 7617
Eastern : 8 th Floor, Plot No 7/7 & 7/8, CP Block, Sector V, Salt Lake, Kolkata, West Bengal 700091	{ 2367 0012 2320 9474
Northern : Plot No. 4-A, Sector 27-B, Madhya Marg, Chandigarh 160019	{ 265 9930
Southern : C.I.T. Campus, IV Cross Road, Taramani, Chennai 600113	{ 2254 1442 2254 1216
Western : 5 th Floor/MTNL CETTM, Technology Street, Hiranandani Gardens, Powai Mumbai 400076	{ 25700030 25702715

Branches : AHMEDABAD, BENGALURU, BHOPAL, BHUBANESHWAR, CHANDIGARH, CHENNAI, COIMBATORE, DEHRADUN, DELHI, FARIDABAD, GHAZIABAD, GUWAHATI, HARYANA (CHANDIGARH), HUBLI, HYDERABAD, JAIPUR, JAMMU, JAMSHEDPUR, KOCHI, KOLKATA, LUCKNOW, MADURAI, MUMBAI, NAGPUR, NOIDA, PARWANOO, PATNA, PUNE, RAIPUR, RAJKOT, SURAT, VIJAYAWADA.