

मस्तिष्क कैनुला — विशिष्टि  
( पहला पुनरीक्षण )

Brain Cannula — Specification  
( First Revision )

ICS 11.040.30

© BIS 2024



भारतीय मानक ब्यूरो  
BUREAU OF INDIAN STANDARDS  
मानक भवन, 9 बहादुर शाह ज़फर मार्ग, नई दिल्ली - 110002  
MANAK BHAVAN, 9 BAHADUR SHAH ZAFAR MARG  
NEW DELHI - 110002  
[www.bis.gov.in](http://www.bis.gov.in) [www.standardsbis.in](http://www.standardsbis.in)

## FOREWORD

This Indian Standard (First Revision) was adopted by the Bureau of Indian Standards after the draft finalized by the Neurosurgery Instruments, Implants & Accessories Sectional Committee had been approved by the Medical Equipment and Hospital Planning Division Council.

This standard was first published as IS 9911 : 1981 'Specification for cannula brain'. This revision aligns the cross references to the latest standards and incorporates the revised designations for stainless steel, Brass bars and method of test for hardness and corrosion resistance.

The composition of the Committee responsible for formulation of this standard is given in [Annex A](#).

For the purpose of deciding whether a particular requirement of this standard is complied with the final value, observed or calculated, expressing the result of a test or analysis shall be rounded off in accordance with IS 2 : 2022 'Rules for rounding off numerical values (*second revision*)'. The number of significant places retained in the rounded off value should be same as that of the specified value in this standard.

*Indian Standard*  
**BRAIN CANNULA — SPECIFICATION**  
*( First Revision )*

**1 SCOPE**

This standard covers materials, dimensions and other requirements for brain cannula, used in neurosurgery.

**2 REFERENCES**

The standards given below contain provisions, which, through reference in this text, constitute provisions of this standard. At the time of publication, the editions indicated were valid. All Standards are subject to revision, and parties to agreements based on this standard are encouraged to investigate the possibility of applying the most recent edition of these standards.

<i>IS No.</i>	<i>Title</i>
IS 319 : 2007	Free cutting brass bars, rods and section — Specification ( <i>fifth revision</i> )
IS 1068 : 1993	Electroplated coatings of nickel plus chromium and copper plus nickel plus chromium — Specification ( <i>third revision</i> )
IS 2112 : 2014	Silver and silver alloys, jewellery/artefacts- fineness and marking — Specification ( <i>third revision</i> )
IS 6528 : 1995	Stainless steel wire — Specification ( <i>first revision</i> )
IS 6911 : 2017	Stainless steel plate, sheet and strip — Specification ( <i>second revision</i> )
IS 7531 : 1990	Methods for testing of corrosion resistance of stainless-steel surgical instruments ( <i>first revision</i> )
IS/ISO 80369-7 : 2016	Small-bore connectors for liquids and gases in healthcare applications: Part 7 Connectors for intravascular or hypodermic applications

**3 SHAPE AND DIMENSIONS**

Shall be as shown in [Fig. 1](#). A deviation of  $\pm 2.5$  percent is permissible on all dimensions.

**4 MATERIAL****4.1 Cannula**

The cannula shall be made of stainless steel conforming to designation X07Cr18Ni9 of IS 6911 : 2017 or fine silver conforming to IS 2112.

**4.2 Hub**

Free cutting brass rod or bar conforming to IS 319.

**4.3 Stilette**

Hard drawn stainless steel wire conforming to IS 6528.

**5 WORKMANSHIP AND FINISH**

**5.1** All surfaces shall be free from pits, dents, burs, scales and other surface defects.

**5.2** The hub of the cannula shall have a female luer taper which shall conform to IS/ISO 80369 (Part 7).

**5.3** The cannula shall be pushed well into the cavity of the hub and securely swaged. The cannula and the hub shall be concentric and well aligned.

**5.4** Stilette supplied with the cannula shall be finished smooth and free from nicks and kinks. Its hall slide smoothly into the cannula.

**5.5** The tip of the cannula shall be of round shape with two suction holes suitably formed and situated as shown in [Fig. 1](#).

**5.6** The hub shall be free from sharp edges and other defects. It shall be plated both inside and outside, chromium over nickel conforming to IS 1068.

**6 TESTS****6.1 Leakage Test**

Connect the cannula to the barrel of a syringe and the open end of the barrel to an air pump, delivering air at a pressure of 100 kPa. Block the cannula outlet by suitable means and start the air pump. Check for any leakage at the joint between the cannula and syringe and other parts of the cannula by dipping into water and observing for leakage in the form of

To access Indian Standards click on the link below:

[https://www.services.bis.gov.in/php/BIS\\_2.0/bisconnect/knowyourstandards/Indian\\_standards/isdetails/](https://www.services.bis.gov.in/php/BIS_2.0/bisconnect/knowyourstandards/Indian_standards/isdetails/)

any bubbles. There shall be no leakage during the test.

**6.2 Security of swaging**

The swaging of the cannula with the hub shall be tested by applying a pull of 90 N for one minute. The cannula shall not come out of the hub and it shall not become loose.

**6.3 Corrosion Resistance Test**

**6.3.1 For Cannula Made of Silver**

The cannula shall be immersed in a 10 percent solution of citric acid at room temperature for 5 h. It shall then be boiled in distilled water for 30 min, and cooled while immersed in the same for 48 h. The cannula or hub shall show no corrosion. The test shall be conducted in a glass container.

**6.3.2 For Cannula Made of Stainless Steel**

The cannula shall not show any sign of corrosion when tested as per IS 7531.

**7 MARKING**

The hub of the cannula shall be marked with the manufacturer’s name, initials or recognized trademark. The cannula shall be graduated lengthwise from 1 to 8, each graduation being marked at a distance of 10 mm from the other as shown in [Fig. 1](#).

**8 BIS CERTIFICATION MARKING**

The product(s) conforming to the requirements of this standard may be certified as per the conformity assessment schemes under the provisions of the *Bureau of Indian Standards Act, 2016* and the Rules and Regulations framed thereunder, and the product(s) may be marked with the Standard Mark.

**9 PACKAGING**

Each cannula with a stiletto shall be packed in accordance with the best trade practices. Alternatively, packing may be done as agreed to between the purchaser and the supplier. On the package of the product batch number, Lot number, and serial number shall be mentioned.

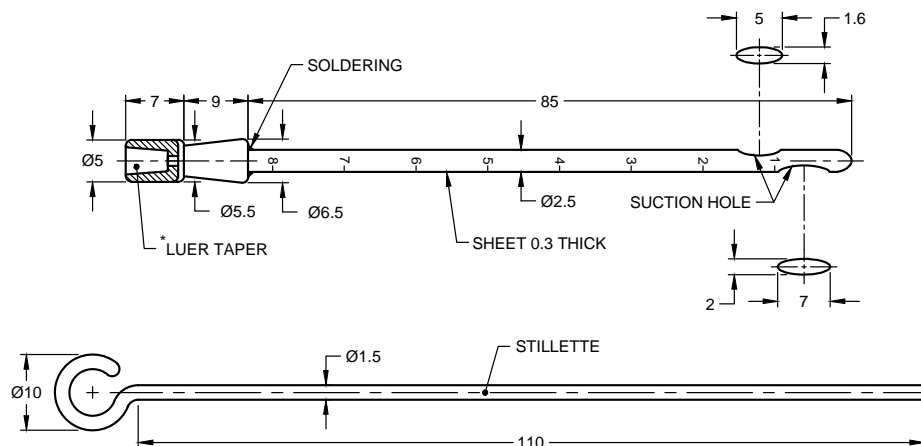

All dimensions in millimetres.

FIG.1 CANNULA, BRAIN

## ANNEX A

*(Foreword)*

## COMMITTEE COMPOSITION

Neurosurgery Instruments Implants and Accessories Sectional Committee, MHD 07

<i>Organization</i>	<i>Representative(s)</i>
G B Pant Hospital, New Delhi	DR DALJIT SINGH ( <i>Chairperson</i> )
Abbott Healthcare India Private Limited, Mumbai	SHRI LIPI CHAKHAIYAR SHRIMATI SHWETA SHARMA ( <i>Alternate</i> )
Association of Indian Medical Device Industry, New Delhi	SHRI NAVEEN KHANNA SHRI PUHAZHENDI KALIYAPPAN ( <i>Alternate I</i> ) SHRI ANKUR BHARGAVA ( <i>Alternate II</i> )
Boston Scientific India Private Limited, Gurugram	SHRI DEV CHOPRA SHRI PRASHANTH PRABHAKAR ( <i>Alternate</i> )
Central Drugs Standard Control Organization, New Delhi	SHRI ASEEM SAHU MS SHYAMNI SASIDHARAN ( <i>Alternate</i> )
Defence Bio-Engineering and Electromedical Laboratory, Ministry of Defence, Bengaluru	SHRI JAYANT DANIEL SHRI G. SRIPATHY ( <i>Alternate</i> )
Directorate General of Health Services, New Delhi	SHRI AJAY CHOUDHARY SHRI K. B. SHANKER ( <i>Alternate</i> )
Happy Reliable Surgeries Private Limited, Bengaluru	SHRI HEMANT SAVALE SHRI SANJEEV GAUTAM ( <i>Alternate</i> )
Indian Institute of Technology Hyderabad, Hyderabad	SHRI AVINASH ERANKI SHRI KOUSIK SARATHY S. ( <i>Alternate</i> )
Kalam Institute of Health Technology, Vishakhapatnam	SHRI SANTOSH KUMAR BALIVADA SHRIMATI DIVYA ANIL PATIL ( <i>Alternate I</i> ) SHRI PURVA SUHAS PHALKE ( <i>Alternate II</i> )
Skull Base Surgery Society of India, Chennai	SHRI HARSH DEORA
In Personal Capacity ( <i>Office Floor, The Suryaa Hotel, New Friends Colony, New Delhi</i> )	SHRI ASOK KUMAR RAGHAVAN NAIR
BIS Directorate General	SHRI A. R. UNNIKISHNAN, SCIENTIST 'G' AND HEAD (MEDICAL EQUIPMENT AND HOSPITAL PLANNING) [REPRESENTING DIRECTOR GENERAL ( <i>Ex-officio</i> )]

*Member Secretary*

MS HARSHADA GANESH KADAM  
SCIENTIST 'B'/ASSISTANT DIRECTOR  
(MEDICAL EQUIPMENT AND HOSPITAL PLANNING), BIS





## Bureau of Indian Standards

BIS is a statutory institution established under the *Bureau of Indian Standards Act, 2016* to promote harmonious development of the activities of standardization, marking and quality certification of goods and attending to connected matters in the country.

### Copyright

BIS has the copyright of all its publications. No part of these publications may be reproduced in any form without the prior permission in writing of BIS. This does not preclude the free use, in the course of implementing the standard, of necessary details, such as symbols and sizes, type or grade designations. Enquiries relating to copyright be addressed to the Head (Publication & Sales), BIS.

### Review of Indian Standards

Amendments are issued to standards as the need arises on the basis of comments. Standards are also reviewed periodically; a standard along with amendments is reaffirmed when such review indicates that no changes are needed; if the review indicates that changes are needed, it is taken up for revision. Users of Indian Standards should ascertain that they are in possession of the latest amendments or edition by referring to the website-[www.bis.gov.in](http://www.bis.gov.in) or [www.standardsbis.in](http://www.standardsbis.in).

This Indian Standard has been developed from Doc No.: MHD 07 (25867).

### Amendments Issued Since Publication

Amend No.	Date of Issue	Text Affected

## BUREAU OF INDIAN STANDARDS

### Headquarters:

Manak Bhavan, 9 Bahadur Shah Zafar Marg, New Delhi 110002

Telephones: 2323 0131, 2323 3375, 2323 9402

Website: [www.bis.gov.in](http://www.bis.gov.in)

### Regional Offices:

	Telephones
Central : 601/A, Konnectus Tower -1, 6 <sup>th</sup> Floor, DMRC Building, Bhavbhuti Marg, New Delhi 110002	{ 2323 7617
Eastern : 8 <sup>th</sup> Floor, Plot No 7/7 & 7/8, CP Block, Sector V, Salt Lake, Kolkata, West Bengal 700091	{ 2367 0012 2320 9474
Northern : Plot No. 4-A, Sector 27-B, Madhya Marg, Chandigarh 160019	{ 265 9930
Southern : C.I.T. Campus, IV Cross Road, Taramani, Chennai 600113	{ 2254 1442 2254 1216
Western : 5 <sup>th</sup> Floor/MTNL CETTM, Technology Street, Hiranandani Gardens, Powai Mumbai 400076	{ 25700030 25702715

**Branches :** AHMEDABAD, BENGALURU, BHOPAL, BHUBANESHWAR, CHANDIGARH, CHENNAI, COIMBATORE, DEHRADUN, DELHI, FARIDABAD, GHAZIABAD, GUWAHATI, HARYANA (CHANDIGARH), HUBLI, HYDERABAD, JAIPUR, JAMMU, JAMSHEDPUR, KOCHI, KOLKATA, LUCKNOW, MADURAI, MUMBAI, NAGPUR, NOIDA, PARWANOO, PATNA, PUNE, RAIPUR, RAJKOT, SURAT, VIJAYAWADA.