

नेत्र संबंधी उपकरण — प्रत्यक्ष नेत्रदर्शी  
(ISO 10942 : 2022, संशोधित)  
(पहला पुनरीक्षण)

Ophthalmic Instruments — Direct  
Ophthalmoscopes  
(ISO 10942 : 2022, MOD)  
( First Revision )

ICS 11.040.70

© BIS 2024  
© ISO 2022



भारतीय मानक ब्यूरो  
BUREAU OF INDIAN STANDARDS  
मानक भवन, 9 बहादुर शाह ज़फर मार्ग, नई दिल्ली - 110002  
MANAK BHAVAN, 9 BAHADUR SHAH ZAFAR MARG  
NEW DELHI - 110002  
[www.bis.gov.in](http://www.bis.gov.in) [www.standardsbis.in](http://www.standardsbis.in)

August 2024

Price Group 7

## NATIONAL FOREWORD

This Indian Standard (First Revision) which is modified adoption of ISO 10942 : 2022 'Ophthalmic instruments — Direct ophthalmoscopes' issued by the International Organization for Standardization was adopted by the Bureau of Indian Standards on the recommendation of the Ophthalmic Instruments and Appliances Sectional Committee and approval of the Medical Equipment and Hospital Planning Division Council.

This Standard was first published in 2014 as IS/ISO 10942:2006 'Ophthalmic instruments — Direct ophthalmoscopes'. The first revision has been undertaken to align it with latest edition of ISO 10942.

The text of ISO Standard has been approved as suitable for publication as an Indian Standard without deviations. Certain conventions are however not identical to those used in Indian Standards. Attention is particularly drawn to the following:

- a) Wherever the words 'International Standard' appear referring to this standard, they should be read as 'Indian Standard'; and
- b) Comma (,) has been used as a decimal marker while in Indian Standards, the current practice is to use a point (.) as the decimal marker.

In this adopted standard, reference appears to certain International Standards for which Indian Standards also exist. The corresponding Indian Standards which are to be substituted in their respective places are listed below along with their degree of equivalence for the editions indicated:

<i>International Standard</i>	<i>Corresponding Standard</i>	<i>Degree of Equivalence</i>
ISO 15004-1 Ophthalmic instruments — Fundamental requirements and test methods — Part 1: General requirements applicable to all ophthalmic instruments	IS 18638 (Part 1) : 2024 Ophthalmic instruments — Fundamental requirements and test methods: Part 1 General requirements applicable to all ophthalmic instruments (ISO 15004-1 : 2020, MOD)	Modified
ISO 15004-2 Ophthalmic instruments — Fundamental requirements and test methods — Part 2: Light hazard protection	IS 18638 (Part 2) : 2024/ISO 15004-2 : 2007 Ophthalmic instruments — Fundamental requirements and test methods: Part 2 Light hazard protection	Identical
IEC 60601-1 : 2005+A1 : 2012 Medical electrical equipment — Part 1: General requirements for basic safety and essential performance	IS 13450 (Part 1) : 2024 Medical electrical equipment: Part 1 General requirements for basic safety and essential performance (IEC 60601-1 : 2020, MOD) ( <i>third revision</i> )	Modified

In this standard, reference to IEC 60601-1 has been modified to IS 13450 (Part 1) : 2024 which is a modified adoption of IEC 60601-1 : 2020.

In this standard, reference to ISO 15004-1 has been modified to IS 18638 (Part 1) : 2024 which is a modified adoption of ISO 15004-1 : 2020.

*(Continued on third cover)*



# Contents

<b>1</b>	<b>Scope</b> .....	<b>1</b>
<b>2</b>	<b>Normative references</b> .....	<b>1</b>
<b>3</b>	<b>Terms and definitions</b> .....	<b>1</b>
<b>4</b>	<b>Classification</b> .....	<b>2</b>
<b>5</b>	<b>Requirements</b> .....	<b>2</b>
	5.1 General.....	2
	5.2 Optical requirements.....	2
	5.3 Construction and function of the viewing system.....	3
	5.4 Construction and function of the illumination system.....	3
	5.5 Optical radiation hazard with direct ophthalmoscopes.....	4
<b>6</b>	<b>Test methods</b> .....	<b>4</b>
	6.1 General.....	4
	6.2 Checking the optical and functional requirements.....	4
<b>7</b>	<b>Accompanying documents</b> .....	<b>5</b>
<b>8</b>	<b>Marking</b> .....	<b>5</b>
	<b>Bibliography</b> .....	<b>6</b>



# OPHTHALMIC INSTRUMENTS — DIRECT OPHTHALMOSCOPES

(ISO 10942 : 2022, MOD)

( First Revision )

## 1 Scope

This document, together with ISO 15004-1 and ISO 15004-2, specifies minimum requirements and test methods for hand-held direct ophthalmoscopes designed for directly observing the eye fundus.

This document takes precedence over ISO 15004-1 and ISO 15004-2, if differences exist.

## 2 Normative references

The following documents are referred to in the text in such a way that some or all of their content constitutes requirements of this document. For dated references, only the edition cited applies. For undated references, the latest edition of the referenced document (including any amendments) applies.

ISO 15004-1, *Ophthalmic instruments — Fundamental requirements and test methods — Part 1: General requirements applicable to all ophthalmic instruments*

ISO 15004-2, *Ophthalmic instruments — Fundamental requirements and test methods — Part 2: Light hazard protection*

IEC 60601-1:2005+A1:2012, *Medical electrical equipment — Part 1: General requirements for basic safety and essential performance*

## 3 Terms and definitions

For the purposes of this document, the following terms and definitions apply.

ISO and IEC maintain terminological databases for use in standardization at the following addresses:

- ISO Online browsing platform: available at <https://www.iso.org/obp>
- IEC Electropedia: available at <https://www.electropedia.org/>

### 3.1

#### **ophthalmoscope**

optical instrument used to examine the external and internal parts of the eye, particularly the media and the fundus

### 3.2

#### **direct ophthalmoscope**

*ophthalmoscope* (3.1) which provides an illuminating system, an observation system and viewing lenses which allow the observer to visualize the patient's eye directly, that is without the formation of an intermediate image

### 3.3

#### **viewing lens**

lens which is positioned between the observer's eye(s) and the eye to be examined in order to achieve optimum focus, i.e. to correct for patient's and/or observer's refractive error and/or accommodation

Note 1 to entry: In direct ophthalmoscopes when a selection of such lenses is required, these are integrated with or mounted in a disc or other mechanical means by which the user can easily position the lens of choice centrally in the visual path.

### **3.4 auxiliary lens**

additional *viewing lens* ([3.3](#)) to facilitate access to higher refractive powers without requiring an excessive number of lenses

Note 1 to entry: Auxiliary lenses are normally integral with or mounted on a separate disc or other mechanical means and when required are used in conjunction with the viewing lenses.

### **3.5 ophthalmoscope graticule**

pattern or target or graticule which can be optionally positioned in the illuminating light path within the instrument and which will be imaged on the retina for diagnostic, measurement or therapeutic purposes

Note 1 to entry: These can be fixed or focusable.

### **3.6 illuminating system**

light source and associated lenses, mirrors and/or prism which serve to provide and project light into or onto the patient's eye

### **3.7 viewing system**

lenses and apertures which enable the observer to examine the patient's eye

### **3.8 field of view**

angular field which is visible when the entrance pupil is 12 mm behind the back surface of the *ophthalmoscope* ([3.1](#)), measured from the centre of the entrance pupil

Note 1 to entry: See [6.2.3](#) and [Figure 1](#).

### **3.9 field of illumination**

angular field which is illuminated and which is measured with its apex positioned at the image of the light source

## **4 Classification**

Direct ophthalmoscopes shall be classified as follows:

- a) Group A: Direct ophthalmoscopes that comply with all the requirements of this document.
- b) Group B: Direct ophthalmoscopes that comply with the reduced requirements specified in [Table 1](#) and all other requirements specified in this document except those in [5.4.2](#) and [5.4.3](#).

## **5 Requirements**

### **5.1 General**

The direct ophthalmoscope shall conform to the requirements specified in ISO 15004-1.

The direct ophthalmoscope shall conform to the specific requirements specified in [5.2](#) to [5.5](#).

These requirements shall be verified as specified in [Clause 6](#).

### **5.2 Optical requirements**

The requirements specified in [Table 1](#) and [Table 2](#) shall apply.

**Table 1 — Requirements for optical specifications**

Criterion	Requirements	
	Group A	Group B
Steps for the powers, in dioptries, of viewing lenses	0, +1, +2, +3, +4, +6, +8, +10, +15, +20, -1, -2, -3, -4, -6, -8, -10, -15, -20	10 steps in the range +10 to 0 to -10
Angle of field of view, $\varphi$	$\geq 3^\circ$	$\geq 2,5^\circ$
Angle of field of illumination at maximum aperture	$\geq 9^\circ$	$\geq 7^\circ$
Diameter of the viewing system	$\geq 3$ mm	$\geq 2,5$ mm

**Table 2 — Requirements for optical accuracy**

Criterion	Combined refractive power	Tolerance
Accuracy of combined refractive power (viewing lens and auxiliary lens)	0 D to +3 D 0 D to -3 D	$\pm 0,37$ D
	> +3 D to +10 D < -3 D to -10 D	$\pm 0,50$ D
	> +10 D to +15 D < -10 D to -15 D	$\pm 0,75$ D
	> +15 D < -15 D	$\pm 1,00$ D
Viewing lens centration	0 D to +10 D 0 D to -10 D	1,0 mm
	> +10 D < -10 D	0,5 mm

### 5.3 Construction and function of the viewing system

**5.3.1** The viewing lenses shall be arranged so that, as viewed from the observer's side:

- a) increments of positive power, indicated by black or green figures, increase when the disc is turned clockwise;
- b) increments of negative power, indicated by red figures, increase when the disc is turned anticlockwise.

**5.3.2** The viewing lens control shall be provided with indexing stops for each lens power.

**5.3.3** Left-hand and right-hand operation of the viewing lens control shall be possible.

### 5.4 Construction and function of the illumination system

**5.4.1** The defocused illumination beam shall be homogenous and achromatic as determined by visual inspection.

**5.4.2** The minimum adjustment range of the luminous flux from the illuminating system of Group A direct ophthalmoscopes shall be from the maximum to 10 % of the maximum.

**5.4.3** Group A direct ophthalmoscopes shall have a minimum of two aperture stops in the illuminating system. These shall be a full aperture and a reduced aperture. Additionally a red-free filter shall be included.

NOTE Other filters, apertures, ophthalmoscope graticules, slits or half-circles are optional.

## 5.5 Optical radiation hazard with direct ophthalmoscopes

This clause replaces IEC 60601-1:2005+A1:2012, 10.4, 10.5, 10.6 and 10.7

The direct ophthalmoscope shall conform to the relevant requirements in accordance with ISO 15004-2.

## 6 Test methods

### 6.1 General

All tests described in this document are type tests.

### 6.2 Checking the optical and functional requirements

**6.2.1** The requirements specified in [5.2](#) shall be verified by the use of measuring devices with accuracy better than 10 % of the smallest value to be determined.

Measurements shall be carried out according to general rules of statistical evaluation.

For measuring the refractive power according to [Table 2](#), a focimeter as specified in ISO 8598-1 should be used.

**6.2.2** For measuring the field of view, place the direct ophthalmoscope so that the back surface of the instrument is 12 mm in front of a pin-hole illuminated by a non-collimated light source.

**6.2.3** The requirements described in [5.3](#) and [5.4.1](#) shall be checked by observation.

It is essential that the divergent angle of the light source exceed the minimum angle of field of view specified in [Table 1](#).

Project the light patch onto a screen at a distance  $l$  (expressed in millimetres) from the pin-hole (see [Figure 1](#)). Measure the diameter  $d$  (expressed in millimetres) of the fully illuminated, central core of the patch, disregarding the penumbra rim.

For the purposes of this measurement, use a 0,2 mm diameter pin-hole and calculate the angle of field of view,  $\varphi$ , from [Formula \(1\)](#):

$$\varphi = 2 \tan^{-1} \left( \frac{d - 0,2}{2l} \right) \quad (1)$$

where

$d$  is the diameter, expressed in millimetres, of the fully illuminated, central core of the patch, disregarding the penumbra rim;

$l$  is the distance, expressed in millimetres, from the pin-hole to the screen.

If the projected light patch has a shape other than circular, the diameter  $d$  of the smallest circle which will circumscribe the projected light patch is taken as the diameter  $d$ .



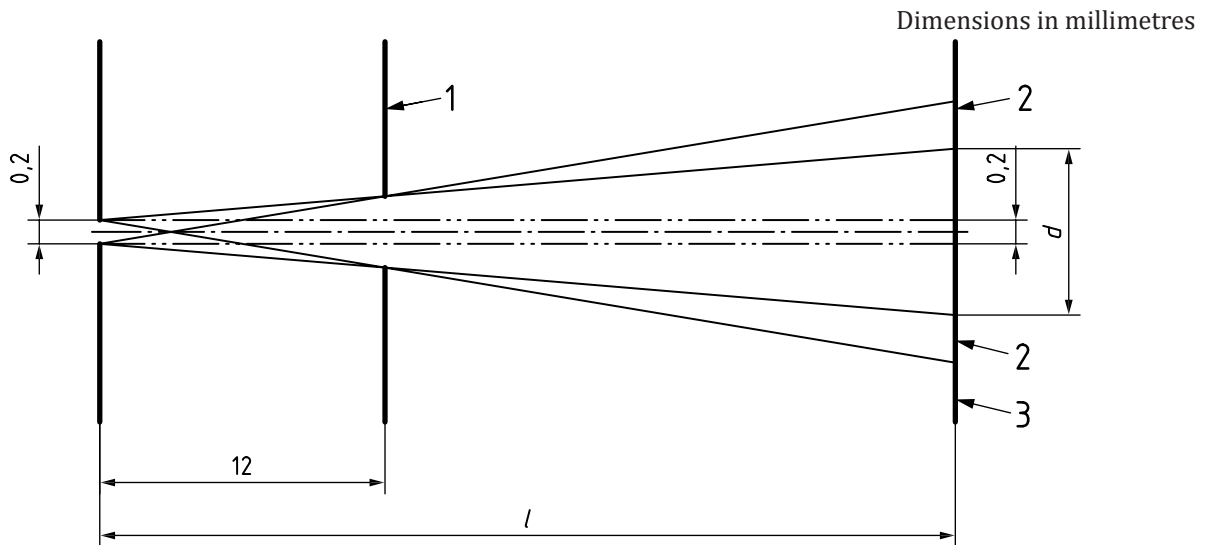

**Key**

- 1 back surface of ophthalmoscope
- 2 penumbra rim
- 3 screen
- $d$  diameter of the fully illuminated, central core of the patch
- $l$  distance from the pin-hole to the screen

**Figure 1 — Test configuration for measuring the field of view**

**7 Accompanying documents**

The direct ophthalmoscope shall be accompanied by documents containing instructions for use. In particular this information shall contain:

- a) the name and address of the manufacturer;
- b) any additional information as specified in IEC 60601-1:2005+A1:2012, 7.9;
- c) a reference to this document (ISO 10942:2022), if the manufacturer or supplier claims compliance with it.

**8 Marking**

The direct ophthalmoscope shall be permanently marked with at least the following information:

- a) the name or trade name and full address of the manufacturer;
- b) where applicable, an authorized representative within the locale;
- c) a distinctive identification i.e. commercial product name, model number or catalogue number;
- d) the classification according to [Clause 4](#);
- e) marking as required by IEC 60601-1.

## Bibliography

- [1] ISO 8598-1, *Optics and optical instruments — Focimeters — Part 1: General purpose instruments*

## NATIONAL ANNEX A

[\(National Foreword\)](#)

### A-1 BIS CERTIFICATION MARKING

The product(s) conforming to the requirements of this standard may be certified as per the conformity assessment schemes under the provisions of the *Bureau of Indian Standards Act, 2016* and the Rules and Regulations framed thereunder, and the product(s) may be marked with the Standard Mark.



[\(Continued from second cover\)](#)

For the purpose of deciding whether a particular requirement of this standard is complied with the final value, observed or calculated, expressing the result of a test or analysis shall be rounded off in accordance with IS 2 : 2022 'Rules for rounding off numerical values (*second revision*)'. The number of significant places retained in the rounded off value should be same as that of the specified value in this standard.

This standard also makes a reference to the BIS Certification Marking of the product. Details of which is given in [National Annex A](#).

## Bureau of Indian Standards

BIS is a statutory institution established under the *Bureau of Indian Standards Act, 2016* to promote harmonious development of the activities of standardization, marking and quality certification of goods and attending to connected matters in the country.

### Copyright

BIS has the copyright of all its publications. No part of these publications may be reproduced in any form without the prior permission in writing of BIS. This does not preclude the free use, in the course of implementing the standard, of necessary details, such as symbols and sizes, type or grade designations. Enquiries relating to copyright be addressed to the Head (Publication & Sales), BIS.

### Review of Indian Standards

Amendments are issued to standards as the need arises on the basis of comments. Standards are also reviewed periodically; a standard along with amendments is reaffirmed when such review indicates that no changes are needed; if the review indicates that changes are needed, it is taken up for revision. Users of Indian Standards should ascertain that they are in possession of the latest amendments or edition by referring to the website-[www.bis.gov.in](http://www.bis.gov.in) or [www.standardsbis.in](http://www.standardsbis.in).

This Indian Standard has been developed from Doc No.: MHD 05 (25356).

### Amendments Issued Since Publication

Amend No.	Date of Issue	Text Affected

## BUREAU OF INDIAN STANDARDS

### Headquarters:

Manak Bhavan, 9 Bahadur Shah Zafar Marg, New Delhi 110002

Telephones: 2323 0131, 2323 3375, 2323 9402

Website: [www.bis.gov.in](http://www.bis.gov.in)

### Regional Offices:

	Telephones
Central : 601/A, Konnectus Tower -1, 6 <sup>th</sup> Floor, DMRC Building, Bhavbhuti Marg, New Delhi 110002	{ 2323 7617
Eastern : 8 <sup>th</sup> Floor, Plot No 7/7 & 7/8, CP Block, Sector V, Salt Lake, Kolkata, West Bengal 700091	{ 2367 0012 2320 9474
Northern : Plot No. 4-A, Sector 27-B, Madhya Marg, Chandigarh 160019	{ 265 9930
Southern : C.I.T. Campus, IV Cross Road, Taramani, Chennai 600113	{ 2254 1442 2254 1216
Western : Manakalya, 5 <sup>th</sup> Floor/MTNL CETTM, Technology Street, Hiranandani Gardens, Powai Mumbai 400076	{ 25700030 25702715

**Branches :** AHMEDABAD, BENGALURU, BHOPAL, BHUBANESHWAR, CHANDIGARH, CHENNAI, COIMBATORE, DEHRADUN, DELHI, FARIDABAD, GHAZIABAD, GUWAHATI, HARYANA (CHANDIGARH), HUBLI, HYDERABAD, JAIPUR, JAMMU, JAMSHEDPUR, KOCHI, KOLKATA, LUCKNOW, MADURAI, MUMBAI, NAGPUR, NOIDA, PARWANOO, PATNA, PUNE, RAIPUR, RAJKOT, SURAT, VIJAYAWADA.