

चिकित्सा विद्युत उपकरण  
भाग 2 बुनियादी सुरक्षा और आवश्यक प्रदर्शन के लिए  
विशेष अपेक्षाएँ  
अनुभाग 87 हाई फ्रीक्वेंसी वेंटिलेटर  
[ISO 80601-2-87 : 2021, संशोधित]

**Medical Electrical Equipment**  
**Part 2 Particular Requirements for Basic**  
**Safety and Essential Performance**  
**Section 87 High Frequency Ventilators**  
[ISO 80601-2-87 : 2021, MOD]

ICS 11.040.10

© BIS 2024

© ISO 2021



भारतीय मानक ब्यूरो  
BUREAU OF INDIAN STANDARDS  
मानक भवन, 9 बहादुर शाह ज़फर मार्ग, नई दिल्ली - 110002  
MANAK BHAVAN, 9 BAHADUR SHAH ZAFAR MARG  
NEW DELHI - 110002  
[www.bis.gov.in](http://www.bis.gov.in) [www.standardsbis.in](http://www.standardsbis.in)

July 2024

₹ 1730



## NATIONAL FOREWORD

This Indian Standard (Part 2) which is a modified adoption of ISO 80601-2-87: 2021 'Medical electrical equipment — Part 2-87: Particular requirements for basic safety and essential performance of high-frequency ventilators' issued by the International Organization for Standardization (ISO) was adopted by the Bureau of Indian Standards on the recommendation of the Anaesthetic, Resuscitation and Allied Equipment Sectional Committee and approval of the Medical Equipment and Hospital Planning Division Council.

The text of ISO standard has been approved as suitable for publication as an Indian Standard without deviations. Certain conventions are however not identical to those used in Indian Standards. Attention is particularly drawn to the following:

- a) Wherever the words 'International Standard' appear referring to this standard, they should be read as 'Indian Standard'; and
- b) Comma (,) has been used as a decimal marker while in Indian Standards, the current practice is to use a point (.) as the decimal marker.

In this adopted standard, reference appears to certain International Standards for which Indian Standards also exist. The corresponding Indian Standards which are to be substituted in their respective places are listed below along with their degree of equivalence for the editions indicated:

<i>International Standard</i>	<i>Corresponding Indian Standard</i>	<i>Degree of Equivalence</i>
ISO 32 : 1977 Gas cylinders for medical use — Marking for identification of content	IS 3933 : 2021 Colour identification of gas cylinders and related equipment intended for medical use ( <i>first revision</i> )	Technically Equivalent
ISO 4871 : 1996 Acoustics — Declaration and verification of noise emission values of machinery and equipment	IS/ISO 4871 : 1996 Acoustics — Declaration and verification of noise emission values of machinery and equipment	Identical
ISO 5356-1 : 2015 Anaesthetic and respiratory equipment — Conical connectors — Part 1: Cones and sockets	IS/ISO 5356-1 : 2015 Anaesthetic and respiratory equipment — Conical connectors: Part 1 Cones and sockets ( <i>first revision</i> )	Identical
ISO 5367 : 2014 Anaesthetic and respiratory equipment — Breathing sets and connectors	IS/ISO 5367 : 2000 Breathing tubes intended for use with anaesthetic apparatus and ventilators	Identical
ISO 7396-1 : 2016 Medical gas pipeline systems — Part 1: Pipeline systems for compressed medical gases and vacuum	IS/ISO 7396-1 : 2007 Medical gas pipeline systems: Part 1 pipeline systems for compressed medical gases and vacuum	Identical
ISO 14937 : 2009 Sterilization of health care products — General requirements for characterization of a sterilizing agent and the development, validation and	IS/ISO 14937 : 2009 Sterilization of health care products — General requirements for characterization of a sterilizing agent and the	Identical

<i>International Standard</i>	<i>Corresponding Indian Standard</i>	<i>Degree of Equivalence</i>
routine control of a sterilization process for medical devices	development validation and routine control of a sterilization process for medical devices	
ISO 16142-1 : 2016 Medical devices — Recognized essential principles of safety and performance of medical devices — Part 1: General essential principles and additional specific essential principles for all non-IVD medical devices and guidance on the selection of standards	IS/ISO 16142-1 : 2016 Medical devices — Recognized essential principles of safety and performance of medical devices: Part 1 General essential principles and additional specific essential principles for all non-ivd medical devices and guidance on the selection of standards	Identical
ISO 17664 : 2017 Processing of health care products — Information to be provided by the medical device manufacturer for the processing of medical devices	IS/ISO 17664 : 2017 Processing of health care products — Information to be provided by the medical device manufacturer for the processing of medical devices	Identical
ISO 20417 : 2020 Medical devices — Information to be supplied by the manufacturer	MHD/14/23491/ISO 20417:2021 Medical devices Information to be supplied by the manufacturer	Non-Identical
ISO 80369-1 : 2018 Small-bore connectors for liquids and gases in healthcare applications — Part 1: General requirements	IS/ISO 80369-1 : 2018 Small-bore connectors for liquids and gases in healthcare applications: Part 1 General requirements	Identical
ISO 80601-2-84 : 2020 Medical electrical equipment — Part 2-84: Particular requirements for basic safety and essential performance of emergency and transport ventilators	IS 13450 (Part 2/Sec 84) : 2023/ Medical electrical equipment: Part 2 Particular requirements for basic safety and essential performance, Section 35 ventilators for emergency medical services environment (ISO 80601-2-84 : 2020, MOD)	Modified
IEC 60068-2-27 : 2008 Environmental testing — Part 2-27: Tests — Test Ea and guidance: Shock	IS 9000 (Part 7/Sec 1) : 2018/ IEC 60068-2-27 : 2008 Basic environmental testing procedures for electronic and electrical items: Part 7 Impact test, Section 1 Shock (test Ea) ( <i>second revision</i> )	Identical
IEC 60068-2-31 : 2008 Environmental testing — Part 2-31: Tests — Test Ec: Rough handling shocks, primarily for equipment-type specimens	IS 9000 (Part 7/Sec 3) : 2019/ IEC 60068-2-31 : 2008 Environmental testing: Part 7 tests, Section 3 Test Ec: Rough handling shocks, primarily for equipment-types specimens ( <i>first revision</i> )	Identical

<i>International Standard</i>	<i>Corresponding Indian Standard</i>	<i>Degree of Equivalence</i>
IEC 60529 : 1989 + AMD1 : 1999 + AMD2 : 2013 Degrees of protection provided by enclosures (IP Code)	IS/IEC 60529 : 2001 Degrees of protection provided by enclosures (IP Code)	Non-Identical
IEC 60601-1 : 2005 + AMD1 : 2012 + AMD2 : 2020 Medical electrical equipment — Part 1: General requirements for basic safety and essential performance	IS 13450 (Part 1) : 2024/ IEC 60601-1: 2020 Medical electrical equipment: Part 1 General requirements for basic safety and essential performance ( <i>third revision</i> )	Modified/Technically Equivalent
IEC 60601-1-12 : 2014 + AMD1 : 2020 Medical electrical equipment — Part 1-12: General requirements for basic safety and essential performance — Collateral Standard: Requirements for medical electrical equipment and medical electrical systems intended for use in the emergency medical services environment	IS 13450 (Part 1/Sec 12) : 2024, Medical electrical equipment: Part 1 General requirements for basic safety and essential performance, Section 12 Requirements for medical electrical equipment and medical electrical systems intended for use in the emergency medical services environment (IEC 60601-1-12: 2020, MOD)	Modified
IEC 62366-1 : 2015 + AMD1 : 2020 Medical devices — Part 1: Application of usability engineering to medical devices	IS 17922 (Part 1) : 2023/ IEC 62366-1 : 2015 + AMD 1 : 2020 Medical devices: Part 1 Application of usability engineering ( <i>first revision</i> )	Identical

The Committee responsible for the preparation of this standard has reviewed the provisions of following mentioned International Standards and has decide that they are acceptable for use in conjunction with this standard:

<i>International Standard/ Other Standards</i>	<i>Title</i>
ISO 3744 : 2010	Acoustics — Determination of sound power levels and sound energy levels of noise sources using sound pressure — Engineering methods for an essentially free field over a reflecting plane
ISO 5359 : 2014 + AMD1 : 2017	Anaesthetic and respiratory equipment — Low-pressure hose assemblies for use with medical gases
ISO 18562-1 : 2017	Biocompatibility evaluation of breathing gas pathways in healthcare applications — Part 1: Evaluation and testing within a risk management process
ISO 20417 : 2020	Medical devices — Information to be supplied by the manufacturer
ISO 23328-1 : 2003	Breathing system filters for anaesthetic and respiratory use — Part 1: Salt test method to assess filtration performance
ISO 23328-2 : 2002	Breathing system filters for anaesthetic and respiratory use — Part 2: Non-filtration aspects

<i>International Standard/ Other Standards</i>	<i>Title</i>
ISO 80601-2-55 : 2018	Medical electrical equipment — Part 2-55: Particular requirements for the basic safety and essential performance of respiratory gas monitors
ISO 80601-2-74 : 2021	Medical electrical equipment — Part 2-74: Particular requirements for the basic safety and essential performance of respiratory humidifying equipment
IEC 60068-2-64 : 2008	Environmental testing — Part 2-64: Tests — Test Fh: Vibration, broadband random and guidance
IEC 60601-1-10 : 2007 + AMD1 : 2020 + AMD2 : 2020	Medical electrical equipment — Part 1-10: General requirements for basic safety and essential performance — Collateral Standard: Requirements for the development of physiologic closed-loop controllers
IEC 60601-1-11 : 2015 + AMD1 : 2020 + AMD2 : 2020	Medical electrical equipment — Part 1-11: General requirements for basic safety and essential performance — Collateral Standard: Requirements for medical electrical equipment and medical electrical systems used in the home healthcare environment
IEC 62570 : 2014	Standard practice for marking medical devices and other items for safety in the magnetic resonance environment

For the purpose of deciding whether a particular requirement of this standard is complied with the final value, observed or calculated, expressing the result of a test or analysis shall be rounded off in accordance with IS 2 : 2022 'Rules for rounding off numerical values (*second revision*)'. The number of significant places retained in the rounded off value should be same as that of the specified value in this standard.

This standard also makes a reference to the BIS Certification Marking of the product, details of which is given in [National Annex A](#).

## Contents

201.1	Scope, object and related standards.....	1
201.2	Normative references .....	4
201.3	Terms and definitions.....	6
201.4	General requirements.....	21
201.5	General requirements for testing of <i>ME equipment</i> .....	28
201.6	Classification of <i>ME equipment</i> and <i>ME systems</i> .....	29
201.7	<i>ME equipment</i> identification, <i>marking</i> and documents.....	29
201.8	Protection against electrical <i>hazards</i> from <i>ME equipment</i> .....	35
201.9	Protection against <i>mechanical hazards</i> of <i>ME equipment</i> and <i>ME systems</i> .....	36
201.10	Protection against unwanted and excessive radiation <i>hazards</i> .....	39
201.11	Protection against excessive temperatures and other <i>hazards</i> .....	39
201.12	Accuracy of controls and instruments and protection against hazardous outputs .....	43
201.13	<i>Hazardous situations</i> and fault conditions for <i>ME equipment</i> .....	60
201.14	<i>Programmable electrical medical systems (PEMS)</i> .....	62
201.15	Construction of <i>ME equipment</i> .....	62
201.16	<i>ME systems</i> .....	66
201.17	Electromagnetic compatibility of <i>ME equipment</i> and <i>ME systems</i> .....	66
201.101	Gas connections.....	66
201.102	Requirements for the <i>HFV breathing system</i> and <i>accessories</i> .....	68
201.103	* Spontaneous breathing during loss of power supply .....	70
201.104	* Indication of duration of operation .....	70
201.105	<i>Functional connection</i> .....	71
201.106	Display loops .....	71
201.107	Timed high-frequency oscillation pause .....	72
202	Electromagnetic disturbances – Requirements and tests.....	72
206	Usability.....	73
208	General requirements, tests and guidance for <i>alarm systems</i> in <i>medical electrical equipment</i> and <i>medical electrical systems</i> .....	75
Annex C (informative)	Guide to <i>marking</i> and labelling requirements for <i>ME equipment</i> and <i>ME systems</i> .....	77
Annex D (informative)	<i>Symbols</i> on <i>marking</i> .....	82
Annex AA (informative)	Particular guidance and rationale.....	83
Annex BB (informative)	Data interface requirements.....	113
Annex CC (informative)	Reference to the <i>IMDRF essential principles</i> and labelling guidances.....	119
Annex DD (informative)	Reference to the <i>essential principles</i> .....	122

Annex EE (informative) Reference to the general safety and performance requirements .....	125
Annex FF (informative) Terminology — alphabetized index of defined terms .....	128
Bibliography.....	133



## Introduction

In this document, the following print types are used:

- Requirements and definitions: roman type;
- *Instructions, test specifications and terms defined in Clause 3 of the general standard, in this document or as noted: italic type;*
- Informative material appearing outside of tables, such as notes, examples and references: in smaller type. Normative text of tables is also in a smaller type.

In referring to the structure of this document, the term

- “clause” means one of the four numbered divisions within the table of contents, inclusive of all subdivisions (e.g. Clause 201 includes subclauses 201.7, 201.8, etc.);
- “subclause” means a numbered subdivision of a clause (e.g. 201.7, 201.8 and 201.9 are all subclauses of Clause 201).

References to clauses within this document are preceded by the term “Clause” followed by the clause number. References to subclauses within this document are by number only.

In this document, the conjunctive “or” is used as an “inclusive or” so a statement is true if any combination of the conditions is true.

For the purposes of this document, the auxiliary verb:

- “shall” means that conformance with a requirement or a test is mandatory for conformance with this document;
- “should” means that conformance with a requirement or a test is recommended but is not mandatory for conformance with this document;
- “may” is used to describe permission (e.g. a permissible way to achieve conformance with a requirement or test);
- “can” is used to describe a possibility or capability; and
- “must” is used to express an external constraint.

Annex C contains a guide to the *marking* and labelling requirements in this document.

Annex D contains a summary of the *symbols* referenced in this document.

An asterisk (\*) as the first character of a title or at the beginning of a paragraph or table title indicates that there is guidance or rationale related to that item in Annex AA.



*Indian Standard*

## MEDICAL ELECTRICAL EQUIPMENT

**PART 2 PARTICULAR REQUIREMENTS FOR BASIC SAFETY AND  
ESSENTIAL PERFORMANCE****SECTION 87 HIGH FREQUENCY VENTILATORS****[ISO 80601-2-87:2021, MOD]****201.1 Scope, object and related standards**

Clause 1 of IEC 60601-1:2005+AMD1:2012+AMD2:2020 applies, except as follows:

NOTE The general standard is IEC 60601-1:2005+AMD1:2012+AMD2:2020.

**201.1.1 \* Scope**

*Replacement:*

This document applies to the *basic safety and essential performance* of a *high-frequency ventilator (HFV)* in combination with its *accessories*, hereafter referred to as *ME equipment*:

- intended for use in an environment that provides specialized care for *patients* whose conditions can be life-threatening and who can require comprehensive care and constant monitoring in a *professional healthcare facility*;

NOTE 1 For the purposes of this document, such an environment is referred to as a critical care environment. *High-frequency ventilators* for this environment are considered life-sustaining.

NOTE 2 For the purposes of this document, such a *high-frequency ventilator* can provide transport within a *professional healthcare facility* (i.e., be a *transit-operable ventilator*).

NOTE 3 A *high-frequency ventilator* intended for use in transport within a *professional healthcare facility* is not considered as a *ventilator* intended for the *emergency medical services environment*.

- intended to be operated by a *healthcare professional operator*;
- intended for those *patients* who need differing levels of support from *artificial ventilation* including *ventilator-dependent patients*; and
- capable of providing more than 150 *inflations/min*.

There are three principal designations of *HFV*:

- high-frequency percussive *ventilation* [HFPV, with a typical *HFV frequency* of (60 to 1 000) *HFV inflations/min*];
- high-frequency jet *ventilation* [HFJV, with a typical *HFV frequency* of (100 to 1 500) *HFV inflations/min*]; and
- high-frequency oscillatory *ventilation* [HFOV, with a typical *HFV frequency* of (180 to 1200) *HFV inflations/min* and typically having an active *expiratory phase*].

Additionally, *HFV* designations can be combined together or with *ventilation* at rates less than 150 *inflations/min*.

\* A *high-frequency ventilator* is not considered a *physiologic closed loop-control system* unless it uses a physiological *patient* variable to adjust the *ventilation* therapy settings.

This document is also applicable to those *accessories* intended by their *manufacturer* to be connected to an *HFV breathing system*, or to a *high-frequency ventilator*, where the characteristics of those *accessories* can affect the *basic safety* or *essential performance* of the *high-frequency ventilator*.

If a clause or subclause is specifically intended to be applicable to *ME equipment* only, or to *ME systems* only, the title and content of that clause or subclause will say so. If that is not the case, the clause or subclause applies both to *ME equipment* and to *ME systems*, as relevant.

*Hazards* inherent in the intended physiological function of *ME equipment* or *ME systems* within the scope of this document are not covered by specific requirements in this document except in 7.2.13 and 8.4.1 of IEC 60601-1:2005.

NOTE 4 Additional information can be found in 4.2 of IEC 60601-1:2005+AMD1:2012.

This document is not applicable to *ME equipment* that is intended solely to augment the *ventilation* of spontaneously breathing *patients* within a *professional healthcare facility*.

This document does not specify the requirements for:

— *non-high-frequency ventilators* or *accessories* which provide conventional *ventilation* for use in critical care environments, which are given in ISO 80601-2-12 [23];

NOTE 5 An *HFV* can incorporate conventional critical care *ventilator operational modes*, in which case ISO 80601-2-12 is applicable to those modes.

— *ventilators* or *accessories* intended for anaesthetic applications, which are given in ISO 80601-2-13 [24];

— *ventilators* or *accessories* intended for the *emergency medical services environment*, which are given in ISO 80601-2-84, the replacement for ISO 10651-3 [13];

NOTE 6 An *HFV* can incorporate *EMS ventilator* capability.

— *ventilators* or *accessories* intended for *ventilator-dependent patients* in the *home healthcare environment*, which are given in ISO 80601-2-72 [26];

— *ventilators* or *accessories* intended for home-care ventilatory support devices, which are given in ISO 80601-2-79 [27] and ISO 80601-2-80 [28], the replacements for ISO 10651-6 [15];

— sleep apnoea breathing therapy *ME equipment*, which are given in ISO 80601-2-70 [25];

— *bi-level positive airway pressure (bi-level PAP) ME equipment*;

— *continuous positive airway pressure (CPAP) ME equipment*;

- respiratory high-flow *ME equipment*, which are given in ISO 80601-2-90:—<sup>1</sup>; and
- cuirass or “iron-lung” *ventilation equipment*.

This document is a particular standard in the IEC 60601 series, the IEC 80601 series and the ISO 80601 series.

### 201.1.2 Object

*Replacement:*

The object of this document is to establish particular *basic safety* and *essential performance* requirements for a *high-frequency ventilator*, as defined in 201.3.201, and its *accessories*.

NOTE 1 *Accessories* are included because the combination of the *high-frequency ventilator* and the *accessories* needs to be adequately safe. *Accessories* can have a significant impact on the *basic safety* or *essential performance* of a *high-frequency ventilator*.

NOTE 2 This document has been prepared to address the relevant *essential principles*<sup>[39]</sup> and labelling<sup>[40]</sup> guidances of the International Medical Devices Regulators Forum (IMDRF) as indicated in Annex CC.

NOTE 3 This document has been prepared to address the relevant *essential principles of safety and performance* of ISO 16142-1:2016 as indicated in Annex DD.

NOTE 4 This document has been prepared to address the relevant general safety and performance requirements of European regulation (EU) 2017/745<sup>[38]</sup> as indicated in Annex FF.

### 201.1.3 Collateral standards

*Amendment (add after existing text):*

This document refers to those applicable collateral standards that are listed in Clause 2 of the general standard and 201.2 of this document.

IEC 60601-1-2, IEC 60601-1-6 and IEC 60601-1-8 apply as modified in Clauses 202, 206 and 208 respectively. IEC 60601-1-3<sup>[29]</sup>, IEC 60601-1-9<sup>[30]</sup>, IEC 60601-1-11 and IEC 60601-1-12<sup>[31]</sup> do not apply. All other published collateral standards in the IEC 60601-1 series apply as published.

### 201.1.4 Particular standards

*Replacement:*

In the IEC 60601 series, particular standards may modify, replace or delete requirements contained in the general standard, including the collateral standards, as appropriate for the particular *ME equipment* under consideration, and may add other *basic safety* or *essential performance* requirements.

A requirement of a particular standard takes priority over IEC 60601-1:2005+AMD1:2012+AMD2:2020 or the collateral standards.

For brevity, IEC 60601-1:2005+AMD1:2012+AMD2:2020 is referred to in this particular document as the general standard. Collateral standards are referred to by their document number.

The numbering of clauses and subclauses of this document corresponds to those of the general standard with the prefix “201” (e.g. 201.1 in this document addresses the content of Clause 1 of

<sup>1</sup> Under preparation. Stage at the time of publication: ISO/DIS 80601-2-90:2020.

the general standard) or applicable collateral standard with the prefix “2xx” where xx is the final digits of the collateral standard document number (e.g. 202.4 in this document addresses the content of Clause 4 of the IEC 60601-1-2 collateral standard, 208.4 in this document addresses the content of Clause 4 of the IEC 60601-1-8 collateral standard, etc.). The changes to the text of the general standard are specified by the use of the following words:

“Replacement” means that the clause or subclause of IEC 60601-1:2005 or the applicable collateral standard is replaced completely by the text of this document.

“Addition” means that the text of this document is additional to the requirements of IEC 60601-1:2005 or the applicable collateral standard.

“Amendment” means that the clause or subclause of IEC 60601-1:2005 or the applicable collateral standard is amended as indicated by the text of this document.

Subclauses, figures or tables that are additional to those of the general standard are numbered starting from 201.101. However, due to the fact that definitions in the general standard are numbered 3.1 through 3.147, additional definitions in this document are numbered beginning from 201.3.201. Additional annexes are lettered AA, BB, etc., and additional items aa), bb), etc.

Subclauses or figures that are additional to those of a collateral standard are numbered starting from 20x, where “x” is the number of the collateral standard, e.g. 202 for IEC 60601-1-2, 203 for IEC 60601-1-3 [29], etc.

The term “this document” is used to make reference to the general standard, any applicable collateral standards and this particular document taken together.

Where there is no corresponding clause or subclause in this document, the clause or subclause of IEC 60601-1:2005+AMD1:2012 or the applicable collateral standard, although possibly not relevant, applies without modification; where it is intended that any part of IEC 60601-1:2005+AMD1:2012 or the applicable collateral standard, although possibly relevant, is not to be applied, a statement to that effect is given in this particular document.

## 201.2 Normative references

The following documents are referred to in the text in such a way that some or all of their content constitutes requirements of this document. For dated references, only the edition cited applies. For undated references, the latest edition of the referenced document (including any amendments) applies.

Clause 2 of IEC 60601-1:2005+AMD1:2012+AMD2:2020 applies, except as follows:

*Replacement:*

ISO 7000:2019, *Graphical symbols for use on equipment — Registered symbols*

ISO 7010:2019, *Graphical symbols — Safety colours and safety signs — Registered safety signs*

IEC 61672-1:2013, *Electroacoustics — Sound level meters — Part 1: Specifications*

*Addition:*

ISO 32:1977, *Gas cylinders for medical use — Marking for identification of content*

ISO 3744:2010, *Acoustics — Determination of sound power levels and sound energy levels of noise sources using sound pressure — Engineering methods for an essentially free field over a reflecting plane*

ISO 4871:1996, *Acoustics — Declaration and verification of noise emission values of machinery and equipment*

ISO 5356-1:2015, *Anaesthetic and respiratory equipment — Conical connectors — Part 1: Cones and sockets*

ISO 5359:2014+AMD1:2017, *Anaesthetic and respiratory equipment – Low-pressure hose assemblies for use with medical gases*

ISO 5367:2014, *Anaesthetic and respiratory equipment – Breathing sets and connectors*

ISO 7396-1:2016, *Medical gas pipeline systems — Part 1: Pipeline systems for compressed medical gases and vacuum*

ISO 14937:2009, *Sterilization of health care products — General requirements for characterization of a sterilizing agent and the development, validation and routine control of a sterilization process for medical devices*

ISO 16142-1:2016, *Medical devices — Recognized essential principles of safety and performance of medical devices — Part 1: General essential principles and additional specific essential principles for all non-IVD medical devices and guidance on the selection of standards*

ISO 17664:2017, *Processing of health care products — Information to be provided by the medical device manufacturer for the processing of medical devices*

ISO 18562-1:2017, *Biocompatibility evaluation of breathing gas pathways in healthcare applications — Part 1: Evaluation and testing within a risk management process*

ISO 20417:2020, *Medical devices — Information to be supplied by the manufacturer*

ISO 23328-1:2003, *Breathing system filters for anaesthetic and respiratory use: — Part 1: Salt test method to assess filtration performance*

ISO 23328-2:2002, *Breathing system filters for anaesthetic and respiratory use: — Part 2: Non-filtration aspects*

ISO 80369-1:2018, *Small-bore connectors for liquids and gases in healthcare applications — Part 1: General requirements*

ISO 80601-2-55:2018, *Medical electrical equipment — Part 2-55: Particular requirements for the basic safety and essential performance of respiratory gas monitors*

ISO 80601-2-74:—<sup>2</sup>, *Medical electrical equipment — Part 2-74: Particular requirements for the basic safety and essential performance of respiratory humidifying equipment*

ISO 80601-2-84:2020, *Medical electrical equipment — Part 2-84: Particular requirements for basic safety and essential performance of emergency and transport ventilators*

IEC 60068-2-27:2008, *Environmental testing — Part 2-27: Tests — Test Ea and guidance: Shock*

IEC 60068-2-31:2008, *Environmental testing — Part 2-31: Tests — Test Ec: Rough handling shocks, primarily for equipment-type specimens*

<sup>2</sup> Under preparation. Stage at the time of publication: ISO/DIS 80601-2-74:2020

IEC 60068-2-64:2008, *Environmental testing — Part 2-64: Tests — Test Fh: Vibration, broadband random and guidance*

IEC 60529:1989+AMD1:1999+AMD2:2013, *Degrees of protection provided by enclosures (IP Code)*

IEC 60601-1:2005+AMD1:2012+AMD2:2020, *Medical electrical equipment — Part 1: General requirements for basic safety and essential performance*

IEC 60601-1-10:2007+AMD1:2020+AMD2:2020, *Medical electrical equipment — Part 1-10: General requirements for basic safety and essential performance – Collateral Standard: Requirements for the development of physiologic closed-loop controllers*

IEC 60601-1-11:2015+AMD1:2020+AMD2:2020, *Medical electrical equipment — Part 1-11: General requirements for basic safety and essential performance — Collateral Standard: Requirements for medical electrical equipment and medical electrical systems used in the home healthcare environment*

IEC 60601-1-12:2014+AMD1:2020, *Medical electrical equipment — Part 1-12: General requirements for basic safety and essential performance — Collateral Standard: Requirements for medical electrical equipment and medical electrical systems intended for use in the emergency medical services environment*

IEC 62366-1:2015+AMD1:2020, *Medical devices — Part 1: Application of usability engineering to medical devices*

IEC 62570:2014, *Standard practice for marking medical devices and other items for safety in the magnetic resonance environment*

### 201.3 Terms and definitions

For the purposes of this document, the terms and definitions given in IEC 60601-1:2005+AMD1:2012+AMD2:2020, IEC 60601-1-2:2014+AMD1:2020, IEC 60601-1-6:2010+AMD1:2013+AMD2:2020, IEC 60601-1-8:2006+AMD1:2012+AMD2:2020 and the following apply.

ISO and IEC maintain terminological databases for use in standardization at the following addresses:

— ISO Online browsing platform: available at <https://www.iso.org/obp>

— IEC Electropedia: available at <http://www.electropedia.org/>

NOTE An alphabetized index of defined terms is found Annex FF.

#### 201.3.201

##### accompanying information

information accompanying or *marked* on a *medical device* or *accessory* (3.1) for the *user* or those accountable for the installation, use, *processing*, maintenance, decommissioning and disposal of the *medical device* or *accessory*, particularly regarding safe use

Note 1 to entry: The *accompanying information* shall be regarded as part of the *medical device* or *accessory*.

Note 2 to entry: The *accompanying information* can consist of the *label*, *marking*, *instructions for use*, *technical description*, installation manual, quick reference guide, etc.



Note 3 to entry: *Accompanying information* is not necessarily a written or printed document but could involve auditory, visual, or tactile materials and multiple media types (e.g., CD/DVD-ROM, USB stick, website).

[SOURCE: ISO 20417:2020, 3.2, modified — deleted note 4.]

### **201.3.202**

#### **airway device**

device intended for use as an interface between the *patient-connection port* of a *ventilator* and the *patient's* airway, and which has no auxiliary features on which the *ventilator* is dependent for its normal operation

EXAMPLE Endotracheal tube; tracheotomy tube; face *mask*; supralaryngeal airway.

Note 1 to entry: The connection to the *patient's* airway can be at the face (non-invasive) or internal to the *patient* (invasive).

Note 2 to entry: A face *mask* that intentionally vents respiratory gas to atmosphere by means of a bleed orifice is a functional part of the *ventilator breathing system* and therefore not an *airway device*. With that arrangement, the face seal of the *mask* becomes the *patient-connection port* and there is no *patient-connection port* connector, nor an *airway device*.

Note 3 to entry: See also *patient-connection port*, *airway* and *ventilator breathing system*.

[SOURCE: ISO 19223:2019, 3.1.3]

### **201.3.203**

#### **airway pressure**

pressure at the *patient-connection port*, relative to ambient pressure unless otherwise specified

Note 1 to entry: In addition to its direct reference, this term or its symbol  $P_{aw}$ , displayed in various character styles, is only used, in context or by qualification, to designate this concept as a measured quantity.

Note 2 to entry: The site(s) of actual measurement(s) may be anywhere in the *ventilator breathing system*, providing that the indicated value is referenced to that at the *patient-connection port*.

Note 3 to entry: This is the generic term for this fundamental concept. Post-coordinated terms, for example, peak inspiratory pressure and baseline *airway pressure*, are used in particular contexts.

Note 4 to entry: Although providing no explicit indication as to where along the *patient's* airway this pressure is measured, this term, along with its symbol, has become widely adopted as referencing the pressure at the point at which *artificial ventilation* equipment is connected to the *patient's* airway or to an *airway device*. This is the final site where a common and replicable pressure can be continuously monitored, conveniently, before breathing gas enters the *patient*.

Note 5 to entry: A pressure measured in the *patient's* airway at a site other than at the *patient-connection port* is referred to in this document as a respiratory pressure.

[SOURCE: ISO 19223:2019, 3.6.1 modified — deleted notes 6 and 7.]

### **201.3.204**

#### **artificial ventilation**

intermittent elevation of the pressure in the *patient's* airway relative to that in the lungs by external means with the intention of augmenting, or totally controlling, the *ventilation* of a *patient*

EXAMPLE Means used to provide *artificial ventilation* are manual resuscitation; mouth-to-mouth resuscitation; automatic *ventilation*; mechanical *ventilation*.

Note 1 to entry: Common classifications of areas of application of *artificial ventilation* are: emergency; transport; home-care; anaesthesia; critical care; rehabilitation.

Note 2 to entry: Classifications used to denote means used for *artificial ventilation* include: positive-pressure; negative-pressure; gas-powered; *operator*-powered; electrically-powered.

Note 3 to entry: Negative-pressure *ventilation* elevates the relative pressure in the airway by intermittently lowering the pressure in the *lungs*.

[SOURCE: ISO 19223:2019, 3.1.10]

### 201.3.205

#### **bi-level positive airway pressure**

##### **bi-level PAP**

sleep-apnoea breathing-therapy mode in which there are two therapeutic positive pressure levels at the *patient-connection port* during the respiratory cycle

Note 1 to entry: The two levels of positive *airway pressure* (PAP) invoked by the various names that have been given to this breathing-therapy mode are typically identified by the terms IPAP (inspiratory positive *airway pressure*) and EPAP (expiratory positive *airway pressure*), with IPAP representing the set inspiratory pressure level during the *patient's* inspiratory phase and EPAP the set baseline *airway pressure* (BAP) during the *patient's* expiratory phase.

Note 2 to entry: This is the generic name for a breathing-therapy mode previously identified by the proprietary name BiPAP®8) (which is not to be confused with the proprietary name BIPAP®7), a *ventilation-mode*).

[SOURCE: ISO 19223:2019, 3.12.5, modified — deleted notes 3 and 4.]

### 201.3.206

#### **bias flow**

flow that passes through the *ventilator breathing system* to the *exhaust port* but is not intended to contribute to the work of *lung ventilation*

Note 1 to entry: In addition to its direct reference, this term may be used to designate this concept, in context or by qualification, as a set.

Note 2 to entry: The term *bias flow* is used to refer to an intended low-level flow that passes right through the *ventilator breathing system* with the purpose of improving the responsiveness and accuracy of the *ventilator's* control and detection systems, and of minimising the rebreathing of expired gas. It is typically only maintained during an *expiratory phase* but can be maintained throughout a respiratory cycle.

[SOURCE: ISO 19223:2019, 3.7.7]

**201.3.207****biocompatibility**

ability to be in contact with a living system without producing an unacceptable adverse effect

Note 1 to entry: Medical devices may produce some level of adverse effect, but that level may be determined to be acceptable when considering the benefits provided by the medical device.

[SOURCE: ISO 18562-1:2017, 3.2]

**201.3.208****breathing system filter****BSF**

device intended to reduce transmission of particulates, including microorganisms, in breathing system

[SOURCE: ISO 4135:—, 3.6.1.4]

**201.3.209****body temperature pressure, saturated****BTPS**

ambient atmospheric pressure, at a temperature of 37 °C, and a relative humidity of 100 %

[SOURCE: ISO 4135:—, 3.1.1.7]

**201.3.210****cleaning**

removal of contaminants to the extent necessary for further processing or for intended use

Note 1 to entry: *Cleaning* consists of the removal, usually with detergent and water, of adherent soil (e.g. blood, protein substances, and other debris) from the surfaces, crevices, serrations, joints, and lumens of a medical device by a manual or automated *process* that prepares the items for safe handling and/or further *processing*.

[SOURCE: ISO 17664:2017, 3.1]

**201.3.211****continuous flow**

gas flowing continuously through the *ventilator breathing system*, with a proportion intermittently passing to the *patient's lung* whenever the *airway pressure* is raised by the *ventilator* or an *operator* action, or flow is demanded by a *patient's* inspiratory effort

Note 1 to entry: In addition to its direct reference, this term may be used to designate this concept, in context or by qualification, as a set value.

Note 2 to entry: A constant, *continuous flow* in the inspiratory limb of the *ventilator breathing system* is commonly used in the *artificial ventilation* of neonatal and paediatric *patients*.

Note 3 to entry: The *airway pressure* can be intermittently raised to a set pressure-limited inspiratory pressure, for example, by the use of an adjustable pressure-relief valve operating in parallel with either the timed occlusions of an expiratory valve, or the manual occlusions of a normally-open *exhaust port*.

[SOURCE: ISO 19223:2019, 3.7.8, modified — deleted note 4.]

### 201.3.212

#### continuous positive airway pressure

##### CPAP

*ventilation*-mode or sleep-apnoea breathing-therapy mode in which the *patient* breathes continuously at a set *airway-pressure* level, above ambient pressure

Note 1 to entry: *CPAP* is intended to maintain the *airway pressure* at its set value apart from the inevitable minor deviations that are necessary for it to perform its function. Although there are currently no tests for acceptable levels for such deviations, they are expected to neither add to nor subtract from the *patient's* perceived work of breathing to a greater extent than could be experienced during natural breathing.

Note 2 to entry: This definition excludes the use of the term to describe *ventilation*-modes where spontaneous inspirations are supported by intermittently elevated pressures other than with the intention to compensate for any actual or perceived imposed work of breathing.

Note 3 to entry: Because, as used for this *ventilation*-mode, the concept of a *CPAP* level coincides with that of a baseline *airway pressure* the setting could be designated as for either concept but as the intention of the *operator* selecting this *ventilation*-mode will be to achieve a specific *CPAP* level, this becomes an acceptable admitted term to designate the set quantity.

Note 4 to entry: Although at the periphery of the spectrum of what constitutes a *ventilation*-mode, *CPAP* is included in this document because it is commonly made available on typical critical care *ventilators* for use as part of a continuum of a *patient's* treatment without the necessity to change to another device.

Note 5 to entry: It is possible for a *ventilation*-mode resembling *CPAP* to be realized on a *ventilator* by the use of CSV (continuous spontaneous *ventilation*) with the pressure-support (PS) set to 'zero' or 'none' but CSV set in this way is not equivalent to *CPAP* if its performance in response to a spontaneous inspiration is dependent on the setting of an appropriate trigger level.

Note 6 to entry: On *ventilators* equipped with ACAP, this adjunct will enable unrestricted breathing whenever *CPAP* is selected.

Note 7 to entry: *CPAP* is a Group 4b *ventilation*-mode. Because no *inflation-type* is selected this *ventilation*-mode is identical to its *ventilation*-pattern and there is no necessity to distinguish between them. The systematic *ventilation*-mode name becomes, therefore, simply, *CPAP*. On *ventilators* where *CPAP* is enabled by means of an ACAP adjunct the systematic code is *CPAP* <ACAP>.

Note 8 to entry: When used for sleep-apnoea breathing-therapy, *CPAP* is not classed as a *ventilation*-mode – it becomes a sleep-apnoea breathing-therapy mode. Although the principle clinical intention of such a therapy mode is to maintain a positive pressure in the *patient's* airway during sleep in order prevent airway obstruction by the soft tissues in the throat it has become a common practice to reduce this pressure during expiration, principally to improve *patient* acceptability. *Ventilation*-modes with this feature are typically identified with names that allude to this use of two levels of positive *airway pressure*. The generic name adopted for the designation of such a breathing-therapy mode in this document is *bi-level PAP*.

[SOURCE: ISO 19223:2019, 3.11.15, modified — deleted note 9.]

### 201.3.213

#### disinfection

*process* to reduce the number of viable microorganisms to a level previously specified as being appropriate for a defined purpose

[SOURCE: ISO 17664:2017, 3.3]

**201.3.214****emergency intake port**

dedicated *gas intake port* through which ambient air is drawn when the supply of fresh gas is insufficient or absent

[SOURCE: ISO 80601-2-12:2020, 201.3.201]

**201.3.215****emergency medical services environment**

actual conditions and settings, in which *operators* interact with the *ME equipment* or *ME system*, in and around the scene of an emergency outside of a professional healthcare facility where a *patient* can be given medical care, basic or advanced life support as well as during professional transport to a professional healthcare facility or between professional healthcare facilities

EXAMPLE 1 Responding to and providing life support at the scene of an emergency to a *patient* reported as experiencing injury or illness in a pre-hospital setting, and transporting the *patient*, while continuing such life support care, to an appropriate professional healthcare facility for further care.

EXAMPLE 2 Providing monitoring, treatment or diagnosis during transport between professional healthcare facilities.

Note 1 to entry: For the purposes of this standard, use of equipment intended for the *EMS environment* and temporarily used in the *home healthcare environment* by emergency medical personnel is considered use in the *EMS environment*.

Note 2 to entry: For the purposes of this standard, the *OPERATORS* of equipment intended for the *EMS environment* are presumed to be professional medical personnel or personnel with relevant specialized training.

Note 3 to entry: Professional healthcare facilities include hospitals, physician offices, freestanding surgical centres, dental offices, freestanding birthing centres, limited care facilities, first aid rooms or rescue rooms and multiple treatment facilities.

[SOURCE: ISO 80601-1-12:2014, 3.1]

**201.3.216****EMS ventilator**

*ventilator* intended for use in the *EMS environment*

[SOURCE: ISO 80601-2-84:2020, 3.1]

**201.3.217****essential principles****essential principles of safety and performance**

fundamental high-level requirements that when complied with ensure a medical device is safe and performs as intended

[SOURCE: ISO 16142-1:2016, 3.3]

**201.3.218****exhaust port**

port of the medical equipment or device from which gas is discharged to the atmosphere during *normal use*, either directly or via an anaesthetic gas scavenging system

[SOURCE: ISO 19223:2019, 3.14.2]

### 201.3.219

#### **expiratory phase**

interval from the start of expiratory flow to the start of inspiratory flow within a respiratory cycle

Note 1 to entry: If additional spontaneous breaths are possible, all or part of their *expiratory phases* can occur within the *expiratory phase* of an assured-*inflation* cycle.

Note 2 to entry: In accordance with the conceptual framework of this document, the phase between *inflations* in any respiratory cycle is the *expiratory phase* of that cycle. For *ventilators* with which there can be simultaneous respiratory cycles, it might not be clear as to which of the cycles is being referenced unless it is specifically associated with the assured-*inflation* cycle each time it is used. This is one of the reasons that the alternative name, *BAP* phase, has been introduced into this document; an introduction that is particularly relevant for use on *ventilators* that facilitate additional breaths in the phase between assured *inflations*. For further information regarding these concepts, see 3.10, 3.11 and 3.12.

Note 3 to entry: If the *patient* generates flow that initiates an *inflation*, the inspiratory flow for the initiated *inflation* cycle is taken as starting at the initiation of the *inflation* phase and any measurable flow in advance of that initiation becomes the trigger flow. If necessary, depending upon the level of granularity required for a specific description of this trigger flow, its duration can be considered to constitute a trigger phase. Because the change from the trigger phase to the *inflation* phase is typically optimized at a level determined by *operator* settings, in this document it is treated as having occurred during the final moments of the *expiratory phase*, unless otherwise stated.

This concept is consistent with the pragmatic view that the set *inspiratory time* should be taken to start at the same point on the pressure rise-time waveform of an *inflation*, whether it is initiated by the *ventilator* or by a *patient*-trigger event (see Figures C.3 and C.4) - also, that the main significance of the actual duration of the *expiratory phase* is as a setting that determines a maximum interval between *inflations*; an aspect that becomes much less critical whenever the patient determines a shorter interval.

If the patient generates inspiratory flow that does not cause a patient-trigger event, then its detectable commencement is treated as the initiation of the inspiratory phase of the subsequent unassisted spontaneous breath.

[SOURCE: ISO 19223:2019, 3.4.2, modified — deleted note 4.]

### 201.3.220

#### **expired minute volume**

volume of gas leaving the *lung* through the *patient-connection port* during all *expiratory phases*, expressed as a volume per minute

Note 1 to entry: In addition to its direct reference, this term or its symbol,  $V_{ME}$ , displayed in various character styles, is used, in context or by qualification, to designate this concept as a measured quantity.

[SOURCE: ISO 19223:2019, 3.8.9, modified —deleted note 2.]

### 201.3.221

#### **fail-safe ventilation**

safety provision by which the *ventilator* automatically switches to a predetermined alternative *ventilation-mode* intended to maintain *patient* safety in the event of a component, sensor or function becoming inoperable

Note 1 to entry: Such provisions could be necessitated by a *ventilator* component failure such as pressure sensor failure or a microprocessor failure.

Note 2 to entry: The automatic initiation of *fail-safe ventilation* usually generates a *technical alarm condition*.

[SOURCE: ISO 19223:2019, 3.7.7]

#### **201.3.222**

##### **flow-direction-sensitive component**

component or *accessory* through which gas flow must be in one direction only for proper functioning or *patient* safety

[SOURCE: ISO 4135:—, 3.1.4.13]

#### **201.3.223**

##### **gas intake port**

port through which gas is drawn for use by the *patient*

[SOURCE: ISO 4135:—, 3.1.4.19]

#### **201.3.224**

##### **gas output port**

port of the *ventilator* through which gas is delivered at respiratory pressures to an *operator-detachable* part of the *ventilator breathing system*

[SOURCE: ISO 19223:2019, 3.14.3]

#### **201.3.225**

##### **gas pathway**

interior surfaces, over which gases or liquids that can be inspired, in a medical device bounded by the ports through which gases or liquids enter and leave the medical device including the *patient* interface or the interior surfaces of *enclosures* that are in contact with gases or liquids that can be inspired

Note 1 to entry: *Patient* contact surfaces such as the outer surfaces of a tracheal tube or the cushion of a *mask* are evaluated according to the ISO 10993 series.

EXAMPLE 1 The *ventilator breathing system*, inlet filter, gas mixer, blower and internal piping.

EXAMPLE 2 Enclosed chamber of an incubator including the mattress or the inner surface of an oxygen hood.

EXAMPLE 3 The inner surfaces of breathing tubes, tracheal tubes or *masks* and mouthpieces.

[SOURCE: ISO 18562-1:2017, 3.5]

#### **201.3.226**

##### **gas return port**

port of the *ventilator* through which gas is returned at respiratory pressures through an *operator-detachable* part of the *ventilator breathing system*, from the *patient-connection port*

[SOURCE: ISO 19223:2019, 3.14.4]

#### **201.3.227**

##### **healthcare professional**

individual with appropriate training, knowledge and skills who provides preventive, curative, promotional or rehabilitative healthcare services in a systematic way to people, families or communities

[SOURCE: ISO 4135:—, 3.1.6.2]

### 201.3.228

#### high-frequency ventilator

##### HFV

*ME equipment* intended to provide *ventilation* of the *lungs* of the *patient* when connected to the airway of the *patient* using a *rate* greater than 150 *inflations/min*

Note 1 to entry: Inflation rates are specified as per minute solely when differentiating from conventional-rate *ventilation*. All normative requirements regarding *HFV* are written using inflation rates per second.

### 201.3.229

#### HFV breathing system

pathways through which gas flows to or from the *HFV* and to or from the *patient*

### 201.3.230

#### HFV frequency

number of *HFV inflations* that are set to occur in a specified period of time, expressed as *HFV inflations per second*

### 201.3.231

#### HFV inflation

periodic *ventilator* action intended to increase the volume of gas in the *lungs*

### 201.3.232

#### HFV volume

volume of gas delivered through the *patient-connection port* or at the distal outlet of the jet system during an *HFV inflation*

Note 1 to entry: The effective volume delivered to the *lung* can be significantly smaller than the *HFV volume*. The leakage of uncuffed tracheal tubes and even small changes in resistance or compliance of the respiratory system (e.g. due to secretions in the airways, through the use of a different *HFV breathing system* or tracheal tube) can change the volume delivered to the *lung*.

Note 2 to entry: The achievable *HFV volume* depends characteristically on the *HFV frequency*. In general, lower *HFV frequencies* permit higher *HFV volumes*.

Note 3 to entry: The *HFV volume* significantly influences CO<sub>2</sub> elimination.

### 201.3.233

#### high-pressure inlet

inlet to which gas is supplied at a pressure exceeding 100 kPa above ambient

[SOURCE: ISO 4135:—, 3.1.4.22]

### 201.3.234

#### home healthcare environment

dwelling place in which a *patient* lives or other places where *patients* are present, excluding professional healthcare facility environments where *operators* with medical training are continually available when *patients* are present

EXAMPLE In a car, bus, train, boat or plane, in a wheelchair or walking outdoors.

Note 1 to entry: Professional healthcare facilities include hospitals, physician offices, freestanding surgical centres, dental offices, freestanding birthing centres, limited care facilities, first aid rooms or rescue rooms, multiple treatment facilities and emergency medical services.



Note 2 to entry: For the purpose of this collateral standard, nursing homes are considered *home healthcare environments*.

Note 3 to entry: Other places where a *patient* is present include the outdoor environment, while working and in vehicles.

[SOURCE: IEC 60601-1-11:2015, 3.1]

### **201.3.235 humidifier**

*ME equipment* that adds water in the form of droplets or vapour, or both, to the inspired gas

Note 1 to entry: This term includes vaporizing, bubble-through and ultrasonic *humidifiers* and active heat and moisture exchangers (HMEs).

[SOURCE: ISO 80601-2-74:—, 201.3.214]

### **201.3.236 I:E ratio**

ratio of the *inspiratory time* to the expiratory time in a respiratory cycle

Note 1 to entry: In addition to its direct reference, this term or its symbol, I:E, may be used, in context or by qualification, to designate this concept as a set quantity or a measured quantity.

Note 2 to entry: By mathematical convention, a colon or a slash is used to designate a ratio between two values so the addition of the word 'ratio' is not strictly necessary. However, its addition is widely practiced and is considered to add to the readability of descriptive texts and lists, but in this document, its use is optional.

[SOURCE: ISO 19223:2019, 3.4.19]

### **201.3.237 inflation**

*ventilator* action intended to increase the volume of gas in the *lungs* by the application of an elevated-pressure waveform to the *patient-connection port* until a specified termination criterion is met

Note 1 to entry: The elevation of the *airway pressure*, above the *PEEP* of the previous phase, during an *inflation* and in the absence of total airway obstruction, generates an inspiratory flow that will either assist or totally control the *inflation* of the *patient's lungs*. This action relieves some of or all the *patient's* work of breathing.

Note 2 to entry: If the *inflation* is pressure-regulated and the inspiratory phase is set to extend beyond the inspiratory-flow time, then the *lungs* are held distended until the *inflation* is terminated. During this inspiratory pause, concurrent breathing can be possible, to the extent determined by the specific *ventilation*-mode selected and whether an ACAP adjunct is provided.

Note 3 to entry: Although, typically, there will be more than one *inflation*-termination criterion, for *patient*-safety reasons, these will always include time-termination, intended as either a primary or secondary means.

Note 4 to entry: If an *inflation* is intended to be terminated by means additional to time, this should be indicated, at least in the *instructions for use*, employing the *inflation-type* systematic naming and coding tables.

Note 5 to entry: The elevated pressure waveform is implemented by either a flow-regulation function or a pressure-regulation function.

Note 6 to entry: This is a context-sensitive term designating an intermittent elevated-pressure *ventilator* parameter, as distinct from a negative-pressure *ventilator inflation* or a *lung inflation* resulting solely from a *patient's* inspiratory effort. When used in its defined context, the preferred term is used by itself but in cases of possible ambiguity, the qualified form, 'positive-pressure inflation', should be used.

Note 7 to entry: The admitted term ventilator inspiration is included to facilitate translation into languages that do not have a translation for the word, *inflation*, as it is used in this context.

[SOURCE: ISO 19223:2019, 3.3.1, modified —deleted note 8.]

### 201.3.238

#### **inflation-type**

*inflation* characterized by its temporal delivery pattern following initiation, and its termination criteria

Note 1 to entry: *Inflation-types* are designated in this document by their property-class common names, wherever possible. They are more precisely designated by the systematic coding scheme, which uses the abbreviations of the common names, where available, but which also often includes designators of additional properties and designates *inflation-types* with no common name yet attributed to them.

Note 2 to entry: A group of *inflation-types* that might be selected for a specific purpose is sometimes given a purpose-class name, but such a name is not an alternative name for that *inflation-type*. As an example, a *pressure-control inflation-type* might be selected to serve as the assured *inflation* within a *ventilation*-mode, but that only makes it the assured 'inflation-type'; a name that identifies its function within a *ventilation*-mode as being assured to be delivered at least at the *set rate* but that does not change its *pressure-control* characteristics.

[SOURCE: ISO 19223:2019, 3.3.2, modified —deleted note 3.]

### 201.3.239

#### **information for safety**

information provided to the *user* or *responsible organization* as a *risk control* measure

EXAMPLE 1 Warnings, precautions or contraindications.

EXAMPLE 2 *Instructions for the use* of a *medical device* to prevent *use error* or avoid a *hazardous situation*.

EXAMPLE 3 Explanation of a safety feature of a *medical device*.

Note 1 to entry: *Information for safety* may be found in any or all types of *information supplied by the manufacturer*.

Note 2 to entry: *Information for safety* can be located on the display of a *medical device* or *accessory*.

[SOURCE: ISO 20417:2020, 3.9]

### **201.3.240**

#### **information supplied by the manufacturer**

information related to the identification and use of a *medical device* or *accessory*, in whatever form provided, intended to ensure the safe and effective use of the *medical device* or *accessory*

Note 1 to entry: For the purposes of this document, *e-documentation* is included in *information supplied by the manufacturer*.

Note 2 to entry: For the purposes of this document, shipping documents and promotional material are excluded from *information supplied by the manufacturer*. However, some *authorities having jurisdiction* can consider such supplemental information as *information supplied by the manufacturer*.

Note 3 to entry: The primary purpose of *information supplied by the manufacturer* is to identify the *medical device* and its *manufacturer*, and provide essential information about its safety, performance, and appropriate use to the *user* or other relevant persons.

[SOURCE: ISO 20417:2020, 3.10, modified — deleted note 4.]

### **201.3.241**

#### **inspiratory time**

duration of an *inflation* phase or inspiratory phase

Note 1 to entry In addition to its direct reference, this term or its symbol,  $t_i$ , may be used, in context or by qualification, to designate this concept as a set quantity or a measured quantity.

Note 2 to entry: The symbol,  $t_i$ , displayed in various character styles, is typically used to designate the *inspiratory time* setting, particularly where space is limited, such as on user interfaces.

[SOURCE: ISO 19223:2019, 3.4.8, modified —deleted notes 3 and 4.]

### **201.3.242**

#### **inspiratory volume**

volume of gas delivered through the *patient-connection port* during an inspiratory or *inflation* phase

Note 1 to entry: In addition to its direct reference, this term or its symbol,  $V_i$ , displayed in various character styles, may only be used, in context or by qualification, to designate this concept as a measured quantity.

Note 2 to entry: This is the concept designated by 'delivered volume', in ISO 4135:2001,3.4.2; a term that has not been widely adopted to date. It is a concept relevant to where measurements of volume made close to the *patient-connection port*, such as is typically the case with self-contained, multi-parameter *patient* monitors, as distinct from the redefined delivered volume, which is applicable to *ventilators* where the inspiratory flow is determined or measured within the body of the *ventilator*. The closer site of measurement means that this quantity only differs from the actual volume entering the *lung* by the amount of any volume loss occurring at the connection to the *patient's* airway.

[SOURCE: ISO 19223:2019, 3.8.3, modified —deleted note 3.]

### 201.3.243

#### instructions for use

##### IFU

portion of the *accompanying information* that is essential for the safe and effective use of a *medical device* or *accessory* directed to the *user* of the *medical device*

Note 1 to entry: For the purposes of this document, a *user* can be either a *lay user* or *professional user* with relevant specialized training.

Note 2 to entry: For the purposes of this document, instructions for the professional *processing* between uses of a *medical device* or *accessory* can be included in the *instructions for use*.

Note 3 to entry: The *instructions for use*, or portions thereof, can be located on the display of a *medical device* or *accessory*.

Note 4 to entry: *Medical devices* or *accessories* that can be used safely and effectively without instructions for use are exempted from having *instructions for use* by some *authorities having jurisdiction*.

[SOURCE: ISO 20417:2020, 3.11, modified — deleted note 5.]

### 201.3.244

#### lay

<adj> term referring to non-professional or professional without relevant specialized training

EXAMPLE *Lay operator, lay responsible organization.*

[SOURCE: IEC 60601-1-11:2015, 3.2]

### 201.3.245

#### lung

each of the pair of compliant organs within the ribcage (thorax), bounded by the terminal bronchiole and the visceral pleura, which during *ventilation* provide gas/blood interfaces that enable oxygen from the gas to pass into the blood and carbon dioxide to be removed

Note 1 to entry: In specific reference to the pair of these organs, in this document the inflection '*lungs*' is used.

Note 2 to entry: In accordance with what has become common practice in the absence of a more suitable term, this term in its singular form is also used in this document to reference the connected, respiratory-gas containing cavities within the respiratory system, consisting of the airway and the *lungs*. Examples of this common practice in applications that are outside the scope of this document are: lung function; lung disease; lung compliance; lung mechanics; test lung. Other established examples are lung ventilator; lung elastance; lung protective strategy.

Note 3 to entry: Although there are no such references in this document, if in the application of this document a need arises to refer to just 'one of the *lungs*' then, in order to avoid any possible ambiguity, it should always be identified as such, or as the 'left *lung*' or 'right *lung*'.

[SOURCE: ISO 19223:2019, 3.1.16, modified —deleted note 4.]

### 201.3.246

#### marking

information, in text or graphical format, durably affixed, printed, etched (or equivalent) to a *medical device* or *accessory*

Note 1 to entry: For the purposes of this document, the term *marked* is used to designate the corresponding act.

Note 2 to entry: For the purposes of this document, *marking* is different from ‘direct marking’ as commonly described in unique device identification (UDI) standards and regulations. A UDI ‘direct marking’ is a type of *marking*.

[SOURCE: ISO 20417:2020, 3.10, modified — deleted note 3.]

### **201.3.247**

#### **mask**

device which provides a non-invasive interface between the *patient's* airway and a *patient-connection port* or other connection to a source of respirable gas

[SOURCE: ISO 4135:—, 3.8.6.4]

### **201.3.248**

#### **maximum limited pressure**

highest *airway pressure* that can occur during *normal use* or under *single fault condition*

Note 1 to entry: In addition to its direct reference as a requirement, this term is only used, in context or by qualification, to designate this concept as a set quantity.

Note 2 to entry: As with all unqualified *airway pressures*, this limited pressure is that at the *patient-connection port* and relative to ambient pressure.

Note 3 to entry: As this is the highest-level precaution against excessive pressures being applied to the *patient's* airway this pressure limit is typically preset by the *manufacturer* but can be made adjustable by the *responsible organization* to a lower pressure level.

[SOURCE: ISO 19223:2019, 3.13.3]

### **201.3.249**

#### **mean airway pressure**

mean value of the pressure as measured at the *patient-connection port* or at the distal outlet of the jet system during high-frequency *ventilation*

### **201.3.250**

#### **medical gas pipeline system**

complete system which comprises a supply system, a monitoring and alarm system and a distribution system with terminal units at the points where medical gases or vacuum are required

[SOURCE: ISO 7396-1:2016, 3.36]

### **201.3.251**

#### **minimum limited pressure**

lowest *airway pressure* that can occur during *normal use* or under *single fault condition*

Note 1 to entry: The *minimum limited pressure* can be sub-atmospheric.

[SOURCE: ISO 4135:—, 3.1.4.39.4]

### **201.3.252**

#### **monitoring equipment**

*medical electrical equipment* or part that continuously or continually measures and indicates the value of a variable to the *operator*

[SOURCE: ISO 4135:—, 3.11.1.2]

### 201.3.253

#### **patient-connection port**

port of a *ventilator breathing system* intended for connection to an *airway device*

Note 1 to entry: The *patient-connection port* is the end of the *ventilator breathing system* proximal to the *patient*.

Note 2 to entry: The *patient-connection port* is typically in the form of a suitable for connection to an *airway device* such as a tracheal or tracheostomy tube, a face *mask*, or a supralaryngeal airway, or to a test apparatus.

Note 3 to entry: Current particular standards typically specify that the *patient-connection port* is required to be in the form of a specific standardized connector(s), for example, a connector(s) conforming to ISO 5356-1.

Note 4 to entry: In *ventilators* designed to provide NIV (non-invasive *ventilation*) and where the *ventilation* function is dependent upon a design feature of a component that connects the *ventilator* to the *patient's* airway, then the *patient-connection port* typically becomes the contact line of the seal to the *patient's* face and there is no *patient-connection-port* connector.

[SOURCE: ISO 19223:2019, 3.14.5, modified — deleted note 5.]

### 201.3.254

#### **patient variable**

*patient* attribute, characteristic, quantity or condition that is measured

EXAMPLE A *patient variable* can be a measure of body chemistry (e.g. electrolytes or blood glucose value), a physical property (e.g. body temperature, electrophysiologic characteristic, hemodynamic quantity), or a pharmaceutical concentration.

[SOURCE: IEC 60601-1-10: 2007+AMD1:2015+AMD2:2020, 3.29]

### 201.3.255

#### **physiologic closed-loop control system**

##### **PCLCS**

part of *ME equipment* or *ME system* used to adjust a physiologic variable (y) relative to a command variable (c) using a feedback variable (f)

[SOURCE: IEC 60601-1-10: 2007+AMD1:2015+AMD2:2020, 3.19]

### 201.3.256

#### **\* pressure amplitude**

magnitude of the pressure swing during high-frequency *ventilation*, as measured at the *patient-connection port* or at the distal outlet of the jet system during high-frequency *ventilation*

### 201.3.257

#### **pressure-control**

*inflation-type* that acts to generate a constant inspiratory pressure at a set level, after a set rise time

Note 1 to entry: After the set rise time, the set inspiratory pressure is typically maintained by means of a pressure-regulation function.

Note 2 to entry: If the *patient* makes an inspiratory effort during a *pressure-control inflation*, this will result in a corresponding increase in inspiratory flow, although not necessarily an increased delivered volume.

Note 3 to entry: If the *patient* makes an expiratory effort during a *pressure-control inflation*, the inspiratory pressure could rise above that set, which might cause immediate termination of the *inflation*. The addition of ACAP enables concurrent unrestricted expiration without termination.

[SOURCE: ISO 19223:2019, 3.3.4, modified — deleted note 4.]

### **201.3.258**

#### **processing**

<preparation of *medical device, accessory*> activity to prepare a new or used *medical device or accessory* for its *intended use*

[SOURCE: ISO 20417:2017, 3.20]

### **201.3.259**

#### **professional healthcare facility**

facility that is continually staffed by suitably trained *healthcare professional operators*

EXAMPLE Hospitals, physician offices, freestanding surgical centres, dental offices, freestanding birthing centres, limited care facilities, first aid rooms or rescue rooms, multiple treatment facilities and emergency medical services.

[SOURCE: ISO 80601-2-12:2020, 201.3.209]

### **201.3.260**

#### **protection device**

part or function of *me equipment* or *accessory* that, without intervention by the *operator*, protects the *patient*, other people or the environment from hazardous output due to incorrect delivery of energy or substances

[SOURCE: ISO 4135:—, 3.1.4.47, modified — replaced 'medical device' with '*me equipment*' and 'user' with '*operator*'.]

### **201.3.261**

#### **recruitment manoeuvre**

temporary increase in the *mean airway pressure* provided during *artificial ventilation*, with or without a momentary pause of the *artificial ventilation*, intended to open the *lungs*

Note 1 to entry: A *recruitment manoeuvre* is used to reduce atelectasis.

Note 2 to entry: A *recruitment manoeuvre* may pause either conventional *ventilation* or the oscillation.

### **201.3.262**

#### **safety sign**

sign giving a general safety message, obtained by a combination of a colour and geometric shape and which, by the addition of a graphical *symbol*, gives a particular safety message

[SOURCE: ISO 20417:2020, 3.21]

### **201.3.263**

#### **set rate**

number of assured *inflations* that are set to occur in a specified period of time, expressed as breaths per minute

Note 1 to entry: In the absence of suitable standardization, *manufacturers* have devised their own abbreviations to denote the various terms relating to respiratory rate for use on user interfaces, where space is often limited, and in user manuals. In the case of *set rate*, it has become widely established custom and practice, when used in context

and without further qualification, to adopt the abbreviation, “Rate”, displayed in various character styles. With the introduction of the term assured *inflation* in this document the adoption of the abbreviation AR displayed in various character styles, to represent assured rate, would be appropriate as an alternative for this purpose.

Note 2 to entry: The *set rate* can be determined by the *operator* either by a direct setting, or indirectly by means of an algorithm (see Example 4).

Note 3 to entry: The *set rate* assures the *operator* that *inflations* of the selected assured *inflation-type* will be delivered at intervals (in minutes) not exceeding, on average, the reciprocal of the *set rate*, although the actual interval between any two successive *inflations* might not be constant.

Note 4 to entry: The deprecated symbol, *f*, and the term that it represents, frequency, are deprecated as synonyms for set rate in this document. Although having similar meanings, rate is the term more usually used in reference to the number of instances occurring in a certain period of time, with no inference that the interval between these instances is constant, whereas frequency has more of the connotation of occurring at constant intervals.

EXAMPLE 1 With an assist/control (A/C) *ventilation-mode*, the *set rate* is the assured minimum *ventilator-initiated inflation* rate; with any *patient-initiated (assist) inflations* the total respiratory rate becomes higher.

EXAMPLE 2 With an IMV (intermittent mandatory *ventilation*) mode, the *set rate* is the rate at which the assured *inflations* are initiated.

EXAMPLE 3 With a SIMV (synchronized intermittent mandatory *ventilation*) mode, the *set rate* is the average rate at which the assured *inflations* are initiated.

EXAMPLE 4 With one means of achieving a MMV (minimum minute volume) *ventilation-mode*, the mode-control algorithm automatically adjusts the *set rate* downwards from its initial setting, as necessary to maintain the set minute volume as a minimum.

[SOURCE: ISO 19223:2019, 3.5.1.1, modified — deleted note 4.]

### 201.3.264

#### single use

<medical device, *accessory*> intended by the *manufacturer* to be used on an individual *patient* or specimen during a single *procedure* and then disposed of

Note 1 to entry: A *single use* medical device or *accessory* is not intended by its *manufacturer* to be further processed and used again.

[SOURCE: ISO 20417:2020, 3.26]

### 201.3.265

#### software item

any identifiable part of a computer program, i.e., source code, object code, control code, control data, or a collection of these items

Note 1 to entry: Three terms identify the software decomposition. The top level is the software system. the lowest level that is not further decomposed is the software unit. All levels of composition, including the top and bottom levels, can be called *software items*. A software system, then, is composed of one or more *software items*, and each *software item* is composed of one or more software units or decomposable *software items*. The responsibility is left to the *manufacturer* to provide the definition and granularity of the *software items* and software units.

[SOURCE: IEC 62304:2006+AMD1:2015, 3.25, modified — deleted note 2.]



**201.3.266****spontaneous breath rate**

total number of spontaneous breaths initiated in a specified period of time, expressed as breaths per minute

Note 1 to entry: In addition to its direct reference, this term, and its symbol,  $RR_{\text{spont}}$ , displayed in various character styles, is only used, in context or by qualification, to designate this concept as a measured quantity.

Note 2 to entry: The *spontaneous breath rate* is the difference between the total respiratory rate and the *ventilator-initiated inflation* rate.

Note 3 to entry: The detection of the beginning and end of a breath is dependent on the sensitivity of the *ventilator* sensors and the thresholds of the detection algorithms. For further information concerning the reliability of using the *patient-triggered* rate as a measure of the *spontaneous-breath rate*.

Note 4 to entry: Because there is no dependent action required, as is the case with assisted breaths, the counting of an unassisted spontaneous breath can be delayed until its inspiratory phase has terminated, thereby allowing a higher level of discrimination between actual breaths and spurious events.

Note 5 to entry: Many legacy *ventilators* display and log the *spontaneous breath rate* as the unassisted breath rate plus the supported breath rate. While true for CSV modes, this practice does not include the spontaneous breaths that can initiate assured *inflations*, for example, in assist/control (A/C) *ventilation* and SIMV modes, making the *spontaneous breath rate* measurement dependent on the *ventilation*-mode that has been selected. This practice is considered to be misleading and is not supported in this document. The admitted term ISO *spontaneous-breath rate* has been included for use where it is necessary to highlight this distinction as, for example, was necessary in ISO/IEEE 11073-10101 [16].

[SOURCE: ISO 19223:2019, 3.5.1.3, modified — deleted note 6.]

**201.3.267****standard temperature and pressure, dry  
STPD**

pressure of 101,325 kPa at an operating temperature of 20 °C, dry

[SOURCE: ISO 4135:—, 3.1.1.7]

**201.3.268****sterile**

free from viable microorganisms

[SOURCE: ISO 20417:2020, 3.28]

**201.3.269****sterilization**

*process* used to render product free from viable microorganisms

Note 1 to entry: In a *sterilization process*, the nature of microbial inactivation is exponential and thus the survival of a microorganism on an individual item can be expressed in terms of probability. While this probability can be reduced to a very low number, it can never be reduced to zero.

[SOURCE: ISO 17664:2017, 3.17]

### 201.3.270

#### **suction catheter**

flexible tube designed for introduction into the respiratory tract or an *airway device* to remove material by suction

[SOURCE: ISO 8836:2019, 3.17]

### 201.3.271

#### **symbol**

graphical representation appearing on the label and/or associated documentation of a medical device that communicates characteristic information without the need for the supplier or receiver of the information to have knowledge of the language of a particular nation or people

Note 1 to entry: The *symbol* can be an abstract pictorial or a graphical representation, or one that uses familiar objects, including alphanumeric characters (with sufficient justification).

[SOURCE: ISO 20417:2020, 3.29]

### 201.3.272

#### **technical description**

portion of the *accompanying information* directed to the *responsible organization* and *service personnel* that is essential for preparation for the first use and safe use, maintenance or repair as well as *processing*, transport or storage for the *expected service life* of a *medical device*

Note 1 to entry: The *technical description* may be included in the *instructions for use*.

[SOURCE: ISO 20417:2020, 3.30, modified — deleted note 2.]

### 201.3.273

#### **transit-operable**

<adj> term referring to *transportable* equipment whose *intended use* includes operation while it is being moved

EXAMPLE Transportable *ME equipment* that is body-worn, hand-held, attached to a wheelchair, or used in a car, bus, train, boat or plane.

Note 1 to entry: For the purpose of this standard, *transit-operable* use in the *home healthcare environment* can include use indoors, outdoors and in vehicles.

[SOURCE: IEC 60601-1-11:2015, 3.4]

### 201.3.274

#### **use error**

user action or lack of user action while using the medical device that leads to a different result than that intended by the *manufacturer* or expected by the user

Note 1 to entry: *Use error* includes the inability of the user to complete a task.

Note 2 to entry: *Use errors* can result from a mismatch between the characteristics of the user, user interface, task, or use environment.

Note 3 to entry: Users might be aware or unaware that a *use error* has occurred.

Note 4 to entry: An unexpected physiological response of the *patient* is not by itself considered *use error*.

Note 5 to entry: A malfunction of a medical device that causes an unexpected result is not considered a *use error*.

[SOURCE: IEC 62366-1:2015, 3.6, modified — deleted note 6.]

### **201.3.275**

#### **validation**

confirmation, through the provision of *objective evidence* that the requirements for a specific *intended use* of application have been fulfilled

Note 1 to entry: The *objective evidence* needed for a validation is the result of a test or other form of determination such as performing alternative calculations or reviewing documents.

Note 2 to entry: The word “*validated*” is used to designate the corresponding status.

Note 3 to entry: The use conditions for validation can be real or simulated.

[SOURCE: ISO 9000:2015, 3.8.13]

### **201.3.276**

#### **ventilator breathing system**

##### **VBS**

pathways through which gas flows to or from the *patient* at respiratory pressures, bounded by the port through which respirable gas enters, the *patient-connection port* and the *gas exhaust port*

Note 1 to entry: These pathways typically extend within and outside the body of the *ventilator*, with those outside being *operator-detachable*.

Note 2 to entry: The port of entry of a respirable gas into the *ventilator breathing system* can be inside the body of the *ventilator* and should not be confused with an external connection port into which respirable gas enters before being reduced to respirable pressures.

[SOURCE: ISO 19223:2019, 3.1.18, modified — deleted notes 3 and 4.]

### **201.3.277**

#### **ventilation**

cyclical movement of a respirable gas into and out of the *lungs*

Note 1 to entry: This might be by external or spontaneous means, or by a combination of both.

[SOURCE: ISO 19223:2019, 3.1.9, modified — deleted note 2.]

### **201.3.278**

#### **ventilator**

medical device or *medical electrical equipment* intended to provide *artificial ventilation*

Note 1 to entry: In cases of possible ambiguity the full term, *lung ventilator*, should be used.

Note 2 to entry: See also *ventilation*.

[SOURCE: ISO 19223:2019, 3.1.1]

### 201.3.279

#### **ventilator operational mode**

way in which a *ventilator* is set to operate

EXAMPLE Standby; calibration; *ventilator breathing system* check; start-up *procedure*.

Note 1 to entry: NIV also becomes an operational mode if it is selectable as an option.

Note 2 to entry: In the absence of the selection of a specific alternative operational mode(s), when *ventilation* is started, typically after a *ventilator* setup routine, a *ventilator* will commence *ventilation* using its intended *ventilation*-mode and as configured by the *operator's* settings and selections.

[SOURCE: ISO 19223:2019, 3.11.1, modified — deleted note 3.]

### 201.3.280

#### **ventilator-dependent**

dependent upon *artificial ventilation* in order to prevent serious deterioration of health or death

Note 1 to entry: A *ventilator-dependent patient* cannot breathe well enough to maintain life-sustaining levels of oxygen and carbon dioxide in the blood.

EXAMPLE Patients with Duchennes Muscular Dystrophy or other degenerative disease resulting in their unsupported respiratory effort being insufficient to sustain life.

[SOURCE: ISO 4135:—, 3.1.5.20]

### 201.3.281

#### **volume-control**

*inflation-type* that generates inspiratory flow to a selected flow-waveform, for a set inspiratory-time, or until the set volume has been delivered

Note 1 to entry: The selected inspiratory-flow waveform is typically that of a constant flow at a set value or of a decreasing flow pattern, sometimes after a set rise time. The constant flow is maintained for the duration of the *inflation* phase by means of a flow-regulation function.

Note 2 to entry: The flow-regulation function typically either maintains the set inspiratory flow or maintains an *inflation-to-inflation* adjusted inspiratory flow with the intention that the set volume is delivered in the set time, particularly when compensating for *ventilator breathing system* characteristics or an airway leak.

[SOURCE: ISO 19223:2019, 3.3.3, modified — deleted note 3.]

## 201.4 General requirements

Clause 4 of IEC 60601-1:2005+AMD1:2012+AMD2:2020 applies, except as follows:

### 201.4.3 *Essential performance*

*Addition:*

#### 201.4.3.101 \* **Additional requirements for *essential performance***

Additional *essential performance* requirements are found in the subclauses listed in Table 201.101.

**201.4.4 Additional requirements for expected service life**

*Amendment (add as a second paragraph):*

In the *risk management file*, the *manufacturer* shall:

- a) state the probability of the *ventilator* needing to be taken out of service due to the failure of a component during the *expected service life* assuming that the preventative inspection, maintenance and calibration are performed according to the *accompanying documents*; and
- b) summarize the methodology used to determine this probability.

**Table 201.101 — Distributed essential performance requirements**

Requirement	Subclause
Delivery of <i>ventilation</i> at the <i>patient-connection port</i> or at the distal outlet of the jet system within the <i>alarm limits</i> set by the <i>operator</i>	a
or generation of an <i>alarm condition</i>	
disconnection	201.12.4.109
gas supply failure	201.13.102
<i>HFV volume</i> , if provided	201.12.4.105
<i>internal electrical power source</i> nears depletion	201.11.8.101
<i>mean airway pressure</i>	201.12.4.102 201.12.4.103
obstruction	201.12.4.108
oxygen level	201.12.4.101
<i>pressure amplitude</i> , if provided	201.12.4.104
<p><sup>a</sup> Subclause 202.8.1.101 indicates methods of evaluating delivery of <i>ventilation</i> as acceptance criteria following specific tests required by this document.</p>	

**201.4.6 \* ME equipment or ME system parts that contact the patient**

*Amendment (add at end of subclause):*

- aa) The *HFV breathing system* or its parts or *accessories* that can come into contact with the *patient* shall be subject to the requirements for *applied parts* according to this subclause.

*Addition:*

**201.4.11.101 \* Additional requirements for pressurized gas input****201.4.11.101.1 Overpressure requirement**

- a) A *ventilator* with a pressurized gas input shall:
  - 1) operate and meet the requirements of this document throughout its *rated* range of input pressure; and
  - 2) not cause an unacceptable *risk* under the *single fault condition* of 1 000 kPa.

- b) A *ventilator* with a maximum *rated* input pressure in excess of 600 kPa shall not cause an unacceptable *risk* under the *single fault condition* of twice the maximum *rated* input pressure.

NOTE 1 Internal pressure regulators can be required to accommodate the *single fault condition* of maximum input pressure as well as the *rated* range of input pressure.

NOTE 2 Under the *single fault condition* of overpressure, it is desirable for gas to continue to flow to the *HFV breathing system*. Under this condition, the flowrate from the *ventilator* is likely to be outside of its specification.

*Check conformance by functional testing in normal use and under normal condition with the most adverse operating settings, by functional testing in single fault condition and inspection of the risk management file.*

#### **201.4.11.101.2 Compatibility requirement**

If the *ventilator* is intended to be connected to a *medical gas pipeline system* conforming with ISO 7396-1:2016 then:

- a) the *rated* range of input pressure shall cover the range specified in ISO 7396-1:2016; and
- b) under *normal condition*,
- 1) the maximum input flowrate required by the *ventilator* for each gas shall not exceed 60 l/min averaged over 10 s at a pressure of 280 kPa, measured at the *gas intake port*; and
  - 2) any transient input flowrate shall not exceed 200 l/min averaged over 3 s,
- or:
- 3) the *accompanying documents* shall disclose:
- i) the 10 s average input flowrate required by the *ventilator* for each gas at a pressure of 280 kPa, measured at the *gas intake port*;
  - ii) the maximum transient input flowrate averaged for 3 s required by the *ventilator* for each gas at a pressure of 280 kPa, measured at the *gas intake port*; and
  - iii) a warning to the effect that this ventilator is a high-flowrate device and should only be connected to a pipeline installation designed using a diversity factor that allows for the indicated high flow at a specified number of terminal outlets, in order to avoid exceeding the pipeline design flow, thereby minimising the risk that the ventilator interferes with the operation of adjacent equipment.

*Check conformance by functional testing in normal use and under normal condition with the most adverse operating settings and by inspection of the accompanying documents.*

EXAMPLE Highest driving gas consumption under worst-case settings for *HFV frequency* and *HFV volume* and worst-case gas pipeline conditions within the *rated* range for inlet pressure.

### **201.5 General requirements for testing of ME equipment**

Clause 5 of IEC 60601-1:2005+AMD1:2012+AMD2:2020 applies, except as follows:

*Addition:*

### **201.5.101 Additional requirements for general requirements for testing of ME equipment**

#### **201.5.101.1 Ventilator test conditions**

- a) For testing, the *ventilator*
  - 1) shall be connected to gas supplies as specified for *normal use*,
  - 2) except that industrial grade oxygen and air may be substituted for the equivalent medical gas, as appropriate, unless otherwise stated.
- b) When using substitute gases, care should be taken to ensure that the test gases are oil-free and appropriately dry.

#### **201.5.101.2 \* Gas flowrate and leakage specifications**

All requirements for gas flowrate, volume and leakage in this document,

- a) are expressed at *STPD*,
- b) except for those associated with the *HFV breathing system*, which are expressed at *BTPS*.

*Correct all test measurements to STPD or BTPS, as appropriate.*

#### **201.5.101.3 \* Ventilator testing errors**

- a) For the purposes of this document, declared tolerances shall be adjusted by the measurement uncertainty.
- b) The *manufacturer* shall disclose the measurement uncertainty for each disclosed tolerance in the *technical description*.

*Check conformance by inspection of the instructions for use and the technical description.*

### **201.6 Classification of ME equipment and ME systems**

Clause 6 of IEC 60601-1:2005+AMD1:2012+AMD2:2020 applies.

### **201.7 ME equipment identification, marking and documents**

Clause 7 of IEC 60601-1:2005+AMD1:2012+AMD2:2020 applies, except as follows:

*Addition:*

#### **201.7.1.101 Information to be supplied by the manufacturer**

The *information supplied by the manufacturer* of a *ventilator* and its accessories shall conform with ISO 20417:2020.

In applying ISO 20417:2020, the terms in this document and those in IEC 60601-1:2005+A1:2012+A2:2020 shall be used as follows.

- a) The term "*accompanying information*" shall assume the same meaning as *accompanying documents*.
- b) The term "*medical device*" shall assume the same meaning as *ME equipment*.

- c) The term "*user*" shall assume the same meaning as *operator*.
- d) The term "*patient*" shall include animals.

*Check conformance by application of ISO 20417:2020.*

### **201.7.2.3 \* Consult accompanying documents**

*Replacement:*

The *ventilator* shall be *marked* with the *safety sign* for the mandatory action: "follow instructions for use", ISO 7010-M002 (see IEC 60601-1:2005 and Technical Corrigendum 1, Table D.2, Number 10).

*Addition:*

### **201.7.2.4.101 Additional requirements for accessories**

- a) *Accessories* supplied separately shall:
  - 1) fulfil the requirements of 201.102.1; and
  - 2) be *marked* with an indication of any limitations or adverse effects of the *accessory* on the *basic safety* or *essential performance* of the *ventilator*, if applicable. See also 201.7.2.17.101 and 201.7.2.101.
- b) If *marking* the *accessory* is not practicable, this information may be placed in the *instructions for use*.

*Check conformance by inspection and inspection of the risk management file for any limitations or adverse effects of the accessory, and where necessary, inspection of the instructions for use.*

### **201.7.2.18 External gas source**

*Amendment (add before the first dash):*

- aa) the gas name or chemical symbol in accordance with ISO 5359:2014;
- bb) the *rated* range of gas pressure;
- cc) for oxygen gas inputs, the *rated* range of oxygen concentration;
- dd) gas-specific colour-coding conforming with ISO 32:1977, if colour coding is used;

EXAMPLE Colour coding to match the colour of the flexible hose or a gas cylinder intended to be attached to the inlet connector.

NOTE In some countries, other colour coding is used.

*Addition:*

### **201.7.2.101 Additional requirements for marking on the outside of ME equipment or ME equipment parts**

- a) The *ME equipment*, parts or *accessories* shall have *clearly legible markings* including
  - 1) an arrow indicating the intended direction of gas flow:



- i) for the *gas output port*; and
  - ii) for the *gas return port*.
- 2) *Symbol* ISO 7000-0794 (Table 201.D.2.101, *symbol* 1) or *symbol* ISO 7000-0795 (Table 201.D.2.101, *symbol* 2) may be used.
- b) If applicable, *operator-accessible ME equipment*, parts or *accessories* shall have *clearly legible markings* of the following
- 1) for a *ventilator* intended to be used in the magnetic resonance (MR) environment,
    - i) *Symbol* 7.3.1-1 (Table 201.D.2.101, *symbol* 3) or *symbol* 7.3.1-2 (Table 201.D.2.101, *symbol* 4) of IEC 62570 for an 'MR Safe' *ventilator*, or
    - ii) *Symbol* 7.3.2 of IEC 62570 (Table 201.D.2.101, *symbol* 5) for an 'MR Conditional' *ventilator*,
 in conforming with IEC 62570:2014.
  - 2) an arrow indicating the direction of the flow for *flow-direction-sensitive components* that are *operator-removable* without the use of a *tool*.
  - 3) a warning not to obstruct the *gas intake port*.

EXAMPLE WARNING: Gas Intake – Do not obstruct

- i) A *symbol* evaluated according to IEC 62366-1 as *information for safety* may be utilized.

*Check conformance by inspection.*

### **201.7.4.3 \* Units of measurement**

IEC 60601-1:2005+AMD1:2012, 7.4.3 applies, except as follows:

*Amendment (add to the bottom as a new row in Table 1):*

All gas volume, flowrate and leakage specifications:

- aa) shall be expressed at *STPD*; except
- bb) those associated with the *HFV breathing system* which shall be expressed at *BTPS*.

*Addition:*

### **201.7.9.2.1.101 Additional general requirements**

The *instructions for use* shall disclose

- a) if the *ventilator*, its parts or *accessories* are intended for *single use*, information on known characteristics and technical factors known to the *manufacturer* that could pose a *risk* if the *ventilator*, its parts or *accessories* would be reused.
- b) the intended range of *patient* weight.

*Check conformance by inspection.*

### 201.7.9.2.2.101 \* Additional requirements for warnings and safety notices

The *instructions for use* shall include

- a) \* a warning statement to the effect that “Warning: Do not cover the ventilator or place in a position that affects proper operation”, including the applicable consequence.

EXAMPLE 1 **WARNING:** Do not position next to a curtain that blocks the flow of cooling air, thereby causing the equipment to overheat, thereby interfering with patient ventilation.

EXAMPLE 2 **WARNING:** Do not block the gas intake port or emergency intake port, thereby interfering with patient ventilation.

- b) \* a warning statement to the effect that “Warning: Always have immediate access to an alternative means of ventilation, which is ready for use, in order to reduce the possibility of patient death or serious deterioration of health.”

EXAMPLE **WARNING:** Failure to have an alternative means of ventilation such as a self-inflating, manually powered resuscitator (as specified in ISO 10651-4<sup>[14]</sup>) with a mask can result in patient death if the ventilator fails.

- c) \* a warning statement to the effect that “WARNING: Do not add any attachments or accessories to the ventilator that are not listed as intended for use in combination with the ventilator in the instructions for use of the ventilator or accessory as the ventilator might not function correctly leading to the risk of patient death or serious deterioration of health.”

If applicable, the *instructions for use* shall include

- d) \* a warning statement to the effect that “Warning: The ventilator shall not be used in a hyperbaric chamber. Such use might cause the ventilator to not function correctly causing patient death or serious deterioration of health.”

- e) \* a warning statement to the effect that “Warning: The ventilator shall not be used with nitric oxide. Such use might cause the ventilator to not function correctly causing patient death or serious deterioration of health.”

- f) \* a warning statement to the effect that “Warning: The ventilator shall not be used with inlet gases that are not specified for use (e.g. helium or mixtures with helium). Such use might cause the ventilator to not function correctly causing patient death or serious deterioration of health.”

- g) \* a warning statement to the effect that “Warning: The ventilator accuracy can be affected by the gas added to the breathing system by use of a pneumatic nebuliser.

- h) \* a warning statement to the effect that “Warning: It is the responsibility of the responsible organization to ensure that the oxygen source is compatible with the rated range of pressure, flowrate and oxygen concentration as marked on the ventilator and indicated in the instructions for use as this can affect the performance of the ventilator that can consequently result in patient death or serious deterioration of health.”

- i) \* a warning statement to the effect that “Warning: When using nebulization or humidification, breathing system filters and heat and moisture exchangers can require more frequent replacement to prevent increased resistance and blockage.”

*Check conformance by inspection.*

**201.7.9.2.8.101 \* Additional requirements for start-up procedure**

NOTE A start-up *procedure* includes a pre-use functional test that is used to determine if the *ventilator* is ready for use.

- a) The *instructions for use* shall disclose a method by which the following can be functionally tested by the *healthcare professional operator* to determine if the *ventilator* operates correctly:
  - 1) the assembled *HFV breathing system*;
  - 2) switchover to and operation from the *internal electrical power source*; and
  - 3) all of the *alarm signals*, including the *alarm signals* from any *distributed alarm systems*.
- b) Portions of this test method may
  - 1) be automatically performed by the *ventilator* or
  - 2) require *healthcare professional operator* action.

EXAMPLE Combination of the power-on self-test routines and *healthcare professional operator* action.

*Check conformance by inspection of the instructions for use.*

**201.7.9.2.9.101 \* Additional requirements for operating instructions**

The *instructions for use* shall disclose

- a) a listing of the following pressures:
  - 1) *maximum limited pressure* ( $P_{Lim,max}$ ); and
  - 2) *minimum limited pressure* ( $P_{Lim,min}$ ), for an *HFV* that can generate subatmospheric pressure in the *expiratory phase*.
- b) \* the *rated range* of all characteristics of the assembled *operator-detachable parts* of the *HFV breathing system* required to maintain the accuracies of set and monitored *HFV volumes* and pressures, for example:
  - 1) *inspiratory gas pathway resistance*,
  - 2) *expiratory gas pathway resistance*, and
  - 3) *HFV breathing system compliance*.
    - i) These specifications may be presented in ranges.
    - ii) The accuracies of set and monitored *HFV volumes* may be presented as a function of these characteristics.

NOTE Compliance and resistance can be non-linear. These characteristics might need to be specified over a range, e.g. at 15 l/min, 30 l/min, 60 l/min and maximum flowrate or the maximum pressure.

- c) the conditions under which the *ventilator* maintains the accuracy of controlled and displayed variables.

EXAMPLE 1 Acceptable range of water level in a *humidifier*.

EXAMPLE 2 Interval of calibration of a flow sensor.

- d) a description of any degradation in accuracy of monitored values with frequency.

EXAMPLE 3 Impaired accuracy of an *HFV volume* monitor at higher frequency due to the time response of a flow transducer.

- e) an explanation of the meaning of the IP classification *marked* on the *ME equipment*.

- f) whether or not the *HFV* is intended for use with closed suctioning.

- g) whether or not the *HFV* is intended for use with nitric oxide and helium.

- h) whether or not the *HFV*

1) is intended for use with nebulized medications, and if so,

2) any constraints.

EXAMPLE Intended for use only with nebulizers or medical drug inhaler that inject droplets without adding carrier gas such as an ultrasonic nebulizer.

- i) when *fail-safe ventilation* is initiated.

- j) the settings of *fail-safe ventilation*.

*Check conformance by inspection.*

#### **201.7.9.2.12 Cleaning, disinfection and sterilization**

*Amendment: (add after normal use)*

or in *single fault condition*

*Amendment: (add after bulleted list)*

- aa) The *instructions for use* shall identify which portions of the *gas pathways* through the *ventilator* can become contaminated with body fluids or by contaminants carried by expired breathing gases during both *normal condition* and *single fault condition*.

*Addition:*

#### **201.7.9.2.14.101 \* Additional requirements for accessories, supplementary equipment, used material**

- a) The *instructions for use* of the *ventilator* shall include a statement to the effect that antistatic or electrically conductive hoses or tubing are not to be used in the *HFV breathing system*.
- b) If applicable, the *instructions for use* of the *ventilator* shall disclose:

- 1) any restrictions on the positioning of components within or connected to the *HFV breathing system*; and

EXAMPLE Where such components are *flow-direction-sensitive components*.

- 2) any adverse effect of any recommended *accessory* on the *essential performance* or *basic safety* of the *ventilator* (additional requirements are found in 201.4.11.101 and 201.16).

*Check conformance by inspection and inspection of the risk management file for any adverse effect of any recommended accessory.*

### **201.7.9.3.1.101 \* Additional general requirements**

a) The *technical description* shall disclose:

- 1) \* a summary description of the filtering or smoothing techniques for measured or computed variables that are displayed or used for control necessary for the *operator* to form a mental model of the operation of the *ventilator*;
- 2) a summary description of the algorithm for how the *mean airway pressure* is calculated; and
- 3) a pneumatic diagram of the *ventilator*, including a diagram for *operator-detachable parts* of the *HFV breathing system* either supplied or recommended in the *instructions for use*.

b) If applicable, the *technical description* shall disclose:

- 1) a summary description of the algorithm for how the *pressure amplitude* is calculated, including the averaging period;
- 2) a summary description of the algorithm for how the *HFV volume* is calculated, including the averaging period; and
- 3) the essential technical characteristics of each recommended *breathing system filter*.

EXAMPLE Deadspace and resistance.

*Check conformance by inspection.*

### **201.7.9.3.101 Additional requirements for the *technical description***

The *technical description* shall disclose:

- a) a description of a *procedure* for checking the function of the *alarm system* for each of the *alarm conditions* specified in this document, if not performed automatically during start-up; and
- b) which checks are performed automatically.

*Check conformance by inspection of the technical description.*

## **201.8 Protection against electrical *hazards* from *ME equipment***

Clause 8 of IEC 60601-1:2005+AMD1:2012+AMD2:2020 applies.

## 201.9 Protection against *mechanical hazards* of *ME equipment* and *ME systems*

Clause 9 of IEC 60601-1:2005+AMD1:2012+AMD2:2020 applies, except as follows:

*Addition:*

### 201.9.6.2.1.101 \* Additional requirements for audible acoustic energy

- a) The A-weighted sound pressure level emitted by the *ventilator* shall be:
- 1) measured in conformance with ISO 4871:1996 and ISO 3744:2010 using engineering method grade 2; and
  - 2) disclosed in the *instructions for use*.
- b) The A-weighted sound power level shall be:
- 1) calculated according to 8.2.5 and 8.6 of ISO 3744:2010; and
  - 2) disclosed in the *instructions for use*.

*Check conformance with the following test:*

- c) *Place the ventilator on the sound-reflecting plane and attach the least favourable HFV breathing system from those indicated in the instructions for use.*

*NOTE* The least favourable HFV breathing system configuration can vary by ventilation-mode, HFV inflation type and flow pattern, as applicable.

- d) *If a humidifier is provided with the ventilator, include the humidifier filled to the least favourable level in the test.*
- e) *Configure the test lung with the compliance and resistance components whose values are indicated in Table 201.102.*
- *Acoustically isolate the test lung and, if applicable the model patient airway, by a suitable means so that any noise from the test lung or the model patient airway does not interfere with the sound measurement of the ventilator.*
  - *Connect the patient-connection port or the distal outlet of the jet system to the test lung.*
- f) *Set the ventilator to generate ventilation as indicated in Table 201.102.*
- g) *Using a microphone of the sound level meter, conforming with the requirements of type 1 instruments specified in IEC 61672-1:2013 measure the maximum time-weighted sound pressure level using frequency weighting A and the time weighting F of the sound level meter (i.e.,  $L_{AFmax}$ ) at 10 positions in a hemisphere with a radius from the geometric centre of the ventilator in a free field over a reflecting plane as specified in 8.1.1 of ISO 3744:2010. Average the values in conformance with 8.2.2 of ISO 3744:2010.*
- h) *Calculate the A-weighted sound pressure level averaged over the measurement surface according to 8.2.2 of ISO 3744:2010.*
- i) *Calculate the A-weighted sound power level according to 8.6 of ISO 3744:2010.*

- j) Confirm that the criteria for background noise specified in 4.2 of ISO 3744:2010 are fulfilled.
- k) Ensure that the measured sound pressure level is less than that disclosed in the instructions for use.

\* Table 201.102 — Test conditions for acoustic tests

Adjustable parameter	Test condition		
	For a ventilator for an intended patient weight of		
	Weight ≤ 8 kg	8 kg ≤ Weight ≤ 45 kg	Weight ≥ 45 kg
Set rate <sup>a</sup>	15 HFV inflations/s	10 HFV inflations/s	5 HFV inflations/s
Mean airway pressure <sup>b</sup>	15 hPa	20 hPa	25 hPa
High-frequency I:E ratio <sup>b</sup>	1:1	1:1	1:1
Pressure amplitude <sup>b</sup>	30 hPa	50 hPa	70 hPa
HFV volume <sup>b</sup>	5 ml	42 ml	165 ml
Linear resistance, $R$ <sup>c</sup> [45][58][61]	50 hPa(l/s) <sup>-1</sup> ±10 %	20 hPa(l/s) <sup>-1</sup> ±10 %	5 hPa(l/s) <sup>-1</sup> ±10 %
Isothermal compliance, $C$ <sup>c</sup>	1 ml hPa <sup>-1</sup> ±10 %	20 ml hPa <sup>-1</sup> ±10 %	50 ml hPa <sup>-1</sup> ±10 %

<sup>a</sup> Set to the nearest available setting.

<sup>b</sup> If provided, set the ventilator to the nearest available settings to achieve these parameters. Use only one of the pressure amplitude or of the HFV volume setting, depending on which parameter is available on the ventilator.

<sup>c</sup> The accuracy for  $C$  and  $R$  applies over the ranges of the measured parameters.

### 201.9.101 \* Additional requirements for suction procedures

For an HFV with a patient-connection port and intended for closed suctioning:

- a) the instructions for use shall disclose recommended ventilation settings for use with a closed suction catheter; and
- b) a ventilator shall continue to function as intended after the use of a closed suction catheter:
- 1) for ventilation with the lowest mean airway pressure of each intended patient weight range indicated in the instructions for use; and
  - 2) using the HFV breathing system configuration with the lowest compliance of those indicated in the instructions for use.

Check conformance by inspection of the instructions for use and with the following test:

- c) Connect a closed suction system, as shown in Figure 201.101, leaving the patient-connection port of the closed suction catheter adaptor open to air and the ventilator disconnected. Utilize a closed suction catheter of minimum inside diameter of 2,95 mm [French (Charriere) equivalent size 14 F].
- d) Adjust the suction equipment as follows:
- Close the flow control valve and adjust the vacuum regulator of the suction equipment to an occluded vacuum of 200 hPa (204 cmH<sub>2</sub>O) below ambient atmospheric pressure.
  - Open and set the flow control valve to give a free air flow (suction flow) of at least:

- 30 l/min, for a ventilator intended for a patient with a weight  $\geq 45$  kg;
  - 15 l/min, for a ventilator intended for a patient with a weight, between 8 kg  $\leq$  weight  $\leq$  45 kg; and
  - 5 l/min, for a ventilator intended for a patient with a weight  $\leq$  8 kg.
- e) Disable the suction flow without affecting the flow control valve setting.
- f) Connect the ventilator as shown in Figure 201.101 utilizing the lowest compliance VBS indicated in the instructions for use for the intended patient weight range. Select the lowest bias flow or continuous flow setting, if available.
- g) Connect a test lung to the patient-connection port of the closed suction catheter adaptor. Utilize a test lung with a compliance of:
- 20 ml hPa<sup>-1</sup>  $\pm 10$  %, for a ventilator intended for a patient with a weight  $\geq 45$  kg;
  - 5 ml hPa<sup>-1</sup>  $\pm 10$  %, for a ventilator intended for a patient with a weight, 8 kg  $\leq$  weight  $\leq$  45 kg; and
  - 0,5 ml hPa<sup>-1</sup>  $\pm 10$  %, for a ventilator intended for a patient with a weight  $\leq$  8 kg.

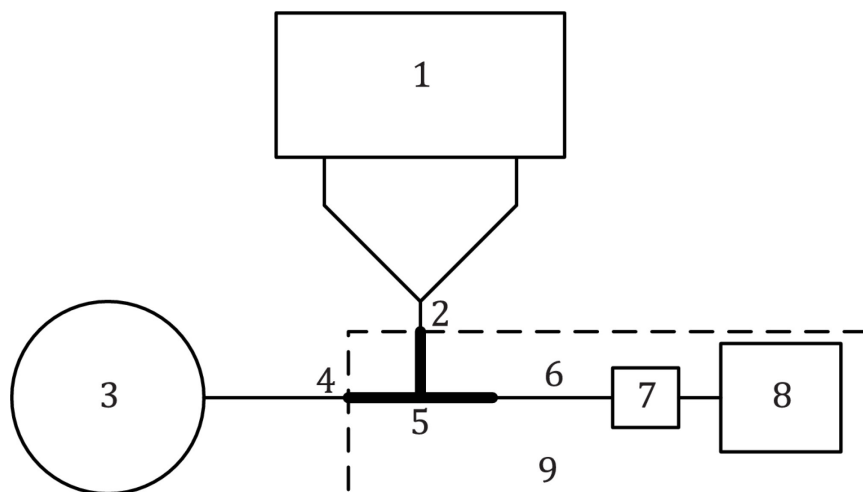

**Key**

- 1 ventilator under test
- 2 patient-connection port of HFV breathing system before adding the closed suction catheter adaptor
- 3 test lung
- 4 patient-connection port of HFV breathing system after adding the closed suction catheter adaptor
- 5 closed suction catheter adaptor
- 6 14 Fr closed suction catheter conforming with ISO 8836:2014 [7]
- 7 flow control valve (can be incorporated in item 8)
- 8 suction equipment conforming with ISO 10079-1:2015+AMD1:2018 [9] or ISO 10079-3:2014 [10]
- 9 suction system

**Figure 201.101 — Typical closed suctioning test setup**

- h) Do not enable any special suction procedure ventilator operational mode and retract the closed suction catheter.
- i) Perform any compliance correction as indicated in the instructions for use.



j) *Select high-frequency ventilation-mode with the following settings for the intended patient weight range from Table 201.102 and, if applicable, minimum bias flow or continuous flow.*

k) *Wait until stability is achieved.*

l) *Advance the closed suction catheter between 1 cm and 2 cm beyond the patient-connection port.*

m) *Enable the suction flow, without affecting the flow control valve setting, and maintain for 30 s.*

NOTE 1 Some *alarm conditions* might become active. This is an expected possibility.

n) *Terminate the suction flow by closing the suction equipment valve and retract the suction catheter.*

NOTE 2 Retracting the *suction catheter* into its supplied sleeve can be important to seal the *gas pathway* and reduce gas leakage.

o) *Wait until stability is achieved.*

p) *Confirm that the ventilator continues to function as intended.*

EXAMPLE The delivered pressure is within specification.

q) *If a suction ventilator operational mode is available, repeat l) to p) with the suction ventilator operational mode enabled.*

r) *Repeat c) to q) for each intended patient weight range.*

## **201.10 Protection against unwanted and excessive radiation hazards**

Clause 10 of IEC 60601-1:2005+AMD1:2012+AMD2:2020 applies.

## **201.11 Protection against excessive temperatures and other hazards**

Clause 11 of IEC 60601-1:2005+AMD1:2012+AMD2:2020 applies, except as follows:

### **201.11.1.2.2 \* Applied parts not intended to supply heat to a patient**

*Amendment (add between the existing paragraphs):*

Over the *rated* flowrate range and at the maximum *rated* operating temperature, the temperature of the gas delivered by the *ventilator* at the *patient-connection port* or at the distal outlet of the jet system, both with and without each *humidifier* specified for use in the *instructions for use*, shall not exceed

aa) 70 °C; and

bb) an energy equivalent to 43 °C and 100 % relative humidity (a specific enthalpy not to exceed 197 kJ/m<sup>3</sup> dry air),

when averaged over 120 s.

Table 201.103 contains examples of combinations of temperature and relative humidity with such a specific enthalpy.

**Table 201.103 — Examples of permissible combinations of temperature and relative humidity**

Temperature °C	Relative humidity %
43	100
44	95
45	90
48	76
50	69
55	52
60	40
65	30
70	23

*Addition:*

**201.11.6.5.101 \* Additional requirements for ingress of water or particulate matter into ME equipment or ME system**

- a) *Enclosures of ventilators shall provide at least an IP21 degree of protection against access to hazardous parts and to the harmful ingress of water.*
- b) *Enclosures of ventilators should provide at least an IP22 degree of protection against access to hazardous parts and to the harmful ingress of water.*

*Check conformance by the tests of IEC 60529:1989+AMD1:1999+AMD2:2013 with the ventilator placed in the least favourable position of normal use and by inspection. After these procedures, confirm that basic safety and essential performance are maintained.*

**201.11.6.6 \* Cleaning and disinfection of ME equipment or ME system**

*Amendment (add additional requirement as new first paragraph):*

- aa) *Gas pathways through the ventilator and its accessories not intended for single use that can become contaminated with body fluids or by contaminants carried by expired gases during normal condition or single fault condition shall be designed to allow dismantling for:*
  - 1) *cleaning and disinfection; or*
  - 2) *cleaning and sterilization.*

NOTE 1 Additional requirements are found in 11.6.7 of IEC 60601-1:2005.

*Amendment (add additional requirement and replace the conformance test):*

- bb) *Ventilator enclosures shall be designed to allow for surface cleaning and disinfection to reduce to acceptable levels the risk of cross infection of the next patient.*

NOTE 2 ISO 14159 <sup>[18]</sup> provides guidance for the design of enclosures.

cc) *Processing procedure* instructions for the *ventilator* and its *accessories* shall:

- 1) conform with ISO 17664:2017 and ISO 14937:2009; and
- 2) be disclosed in the *instructions for use*.

*Check conformance by inspection of the risk management file and conformity with ISO 17664:2017. When conformity with this document could be affected by the cleaning or the disinfection of the ventilator or its parts or accessories, clean and disinfect them for the number of processing cycles and in accordance with the methods indicated in the instructions for use, including any cooling or drying period. After these procedures, ensure that basic safety and essential performance are maintained. Confirm that the manufacturer has evaluated the effects of multiple process cycles and the effectiveness of those cycles.*

#### **201.11.6.7 Sterilization of ME equipment or ME system**

*Amendment (add note before conformance test):*

NOTE Additional requirements are found in 11.6.6 of IEC 60601-1:2005.

#### **201.11.7 Biocompatibility of ME equipment and ME systems**

*Amendment (add after existing text prior to the conformance statement):*

- aa) The *manufacturer* of a *ventilator*, *HFV breathing system*, its parts or *accessories* shall address in the *risk management process* the risks associated with the leaching or leaking of substances into the *gas pathway*.
- bb) The *gas pathways* shall be evaluated for *biocompatibility* according to ISO 18562-1:2017.

*Addition:*

#### **201.11.8.101 \* Additional requirements for interruption of the power supply/supply mains to ME equipment**

The *ventilator* shall be equipped with

- a) an *internal electrical power source* capable of powering the *ventilator* for at least 15 min when the *supply mains* falls outside the values necessary to maintain *patient ventilation*.
  - 1) The *ventilator* may change to *fail-safe ventilation* in this situation.
- b) a means of determining the remaining capacity or operation time provided by the *internal electrical power source*.
  - 1) This indication may be qualitative.
- c) a means to determine the power source that is currently operating the *ventilator*.

*A ventilator that does not initiate fail-safe ventilation following the switchover to the internal electrical power source shall;*

- d) be equipped with an *alarm system* that detects a *technical alarm condition*, or
  - 1) The *alarm condition* for switchover to an *internal electrical power source* shall be at least *low priority*.

e) generate an *information signal* to indicate a switchover to an *internal electrical power source*.

A ventilator that does initiate *fail-safe ventilation* following the switchover to the *internal electrical power source* shall be equipped with an *alarm system* that detects a *technical alarm condition*.

f) This *alarm condition* for switchover to an *internal electrical power source* shall be *high priority*.

g) The associated visual *alarm signal* shall indicate, as appropriate, that the

1) the *ventilation-mode* has changed; or

2) the *ventilator settings* have changed.

The ventilator shall

h) be equipped with an *alarm system* that includes a *technical alarm condition* to indicate when the *internal electrical power source* nears depletion, at least 10 min prior to the loss of *ventilation*.

1) The *internal electrical power source* nears depletion *alarm condition* shall be *medium priority*.

2) As the *internal electrical power source* depletes further, at least 5 min prior to the loss of *ventilation*, the depletion *internal electrical power source technical alarm condition* shall escalate to *high priority*.

The *instructions for use* shall disclose

i) the operational time of the *ventilator* when powered from an aged [see conformance check step k)], fully charged *internal electrical power source*.

j) for each intended *patient weight range* under the conditions of Table 201.102,

1) the means by which the secondary *supply mains*, if provided, can be tested, and

2) the behaviour of the *ventilator* after a switchover:

i) to the *internal electrical power source*; or

ii) to the secondary *supply mains*, if provided.

EXAMPLE 1 Describing which *accessories* or integrated components such as a heated exhalation manifold or a heated *humidifier* no longer remain functional after a switchover to the *internal electrical power source* or a secondary *supply mains*, if provided.

EXAMPLE 2 Describing any limitations to the *ventilation* function after switchover.

3) the behaviour of the *ventilator* while the *internal electrical power source* is recharging.

Check conformance by inspection of the instructions for use, functional testing and the following test.

- k) Age a new internal electrical power source by operating the ventilator from the internal electrical power source using the worst-case intended patient weight and HFV inflation type under the conditions of Table 201.102:
- 1) until the high priority internal electrical power source nears depletion technical alarm condition becomes active;
  - 2) recharge the internal electrical power source by connecting the ventilator to supply mains;
  - 3) repeat 1) and 2) 10 times; and
  - 4) for a transit-operable ventilator, repeat 1) and 2) an additional 40 times.
  - 5) Instead of using the ventilator, discharging and charging circuits may be used with an equivalent profile simulating worst-case conditions:
    - i) over the discharging time; and
    - ii) over the charging time.
- l) Operate the ventilator using the worst-case intended patient weight and HFV inflation type under the conditions of Table 201.102.
- m) Confirm that the medium priority alarm condition occurs at least 10 min prior to the loss of ventilation.
- n) Confirm that the high priority alarm condition occurs at least 5 min prior to the loss of ventilation.

## **201.12 Accuracy of controls and instruments and protection against hazardous outputs**

Clause 12 of IEC 60601-1:2005+AMD1:2012+AMD2:2020 applies, except as follows:

### **201.12.1 \* Accuracy of controls and instruments**

*Amendment (add after existing sentence):*

- aa) The controls of a ventilator shall be *clearly legible* under the conditions specified in 7.1.2 of IEC 60601-1:2005.

*Check conformance by application of the tests of 7.1.2 of IEC 60601-1:2005.*

*Addition:*

#### **201.12.1.101 \* Mean airway pressure**

- a) If control of *mean airway pressure* is provided, with the *high-frequency ventilator* operating in *normal condition*, the accuracy as determined for the test settings and conditions specified in this document shall be disclosed in the *instructions for use*, as the maximum bias error and maximum linearity error.

EXAMPLE ± [3,0 +(5 % of the set pressure)] hPa

- b) This disclosure shall include at least:
- 1) the maximum error of the *mean airway pressure* in relation to the set value;
- c) The accuracy of the performance of the *ventilator* shall either be:
- 1) determined for each *HFV breathing system* configuration indicated in the *instructions for use*; or
  - 2) determined for the worst-case *HFV breathing system* configurations indicated in the *instructions for use*.
- NOTE The worst-case *HFV breathing system* configuration can be different for each error or intended *patient* body weight.
- d) If worst-case *HFV breathing system* configurations are used, the rationale for their selection shall be documented in the *risk management file*.
- e) For an *HFV* without a *patient-connection port*, the *technical description* shall disclose the technical characteristics of each of the *patient* airway models used in Figure 201.103, with scientific justification for critical parameters such as internal diameter and length

*Check conformance by inspection of the risk management file for the rationale, if applicable, and with the following tests:*

- f) *Set up the ventilator as shown in Figure 201.102 (for an HFV with a patient-connection port) or Figure 201.103 (for an HFV without a patient-connection port) using the worst-case HFV breathing system or using the maximum internal volume HFV breathing system. If the HFV breathing system includes a humidifier, use the minimum humidifier water level indicated in the instructions for use.*
- g) *Utilize the test conditions for the first applicable row available on the ventilator (selected by intended patient weight range) in Table 201.104.*
- h) *Wait until equilibrium is reached in the mean airway pressure and pressure amplitude.*
- i) *Using the data acquisition system, measure the pressure waveform for a duration of 10 s and calculate the mean airway pressure as the average value of the measured pressure waveform samples.*
- j) *Repeat g) to i) for each applicable row (selected by intended patient weight range) in Table 201.104.*
- k) *Repeat g) to j) with the maximum humidifier water level indicated in the instructions for use.*

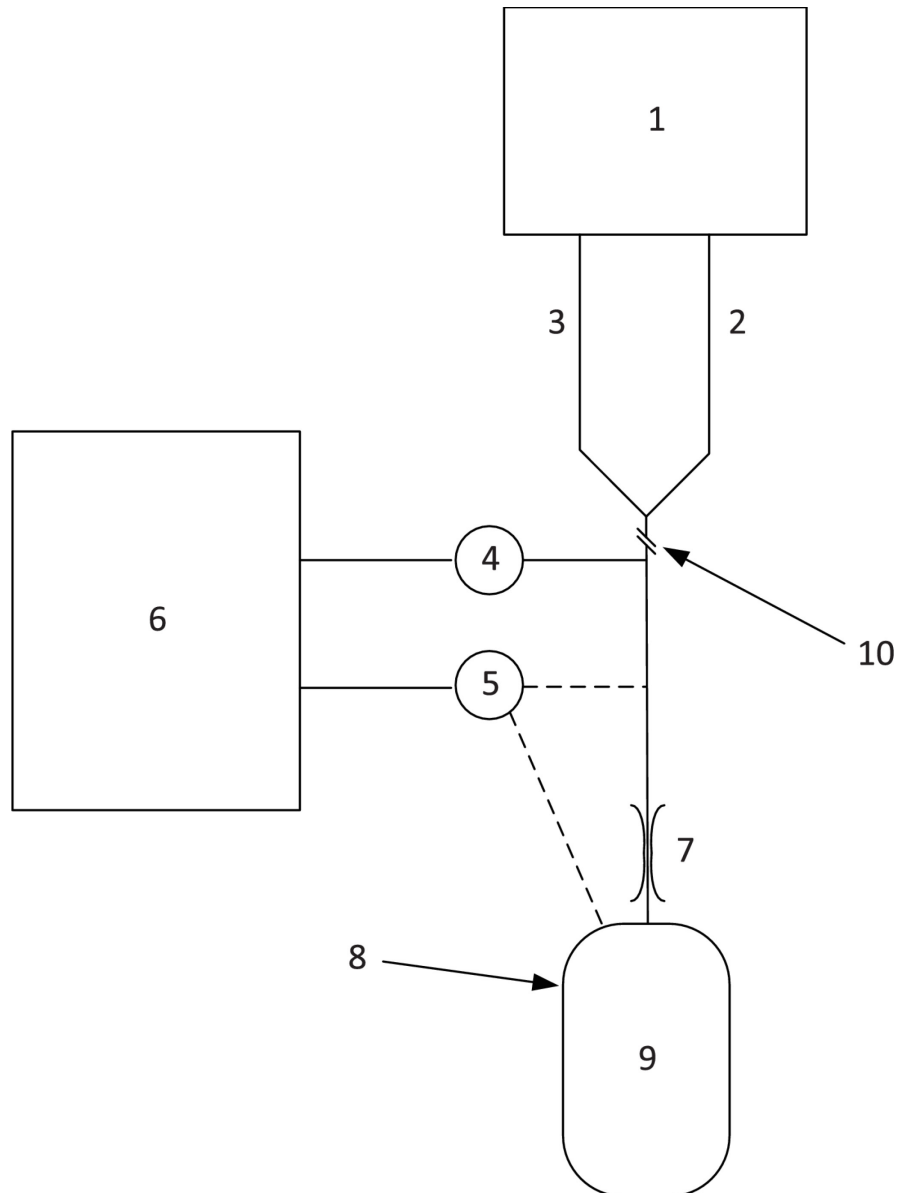

### Key

- 1 ventilator under test
- 2 breathing circuit tubing – inspiratory
- 3 breathing circuit tubing – expiratory
- 4 pressure sensor, with a 10 % to 90 % rise time of no greater than 5 ms (only required for tests measuring *airway pressure*)
- 5 oxygen sensor (connected to the *patient-connection port*, or into test lung shown as dotted lines and only required for tests measuring oxygen concentration)
- 6 data acquisition system, with a minimum sample rate of 1 000 samples/s
- 7 resistance
- 8 test lung
- 9 test lung compliance ( $C_{\text{lung}}$ )
- 10 *patient-connection port*

NOTE The tube between the pressure sensor and the *patient-connection port* is selected so as to minimize its influence on pressure measurement (e.g. the frequency dependent transfer function).

**Figure 201.102 — Performance test setup for an HFV with a *patient-connection port***

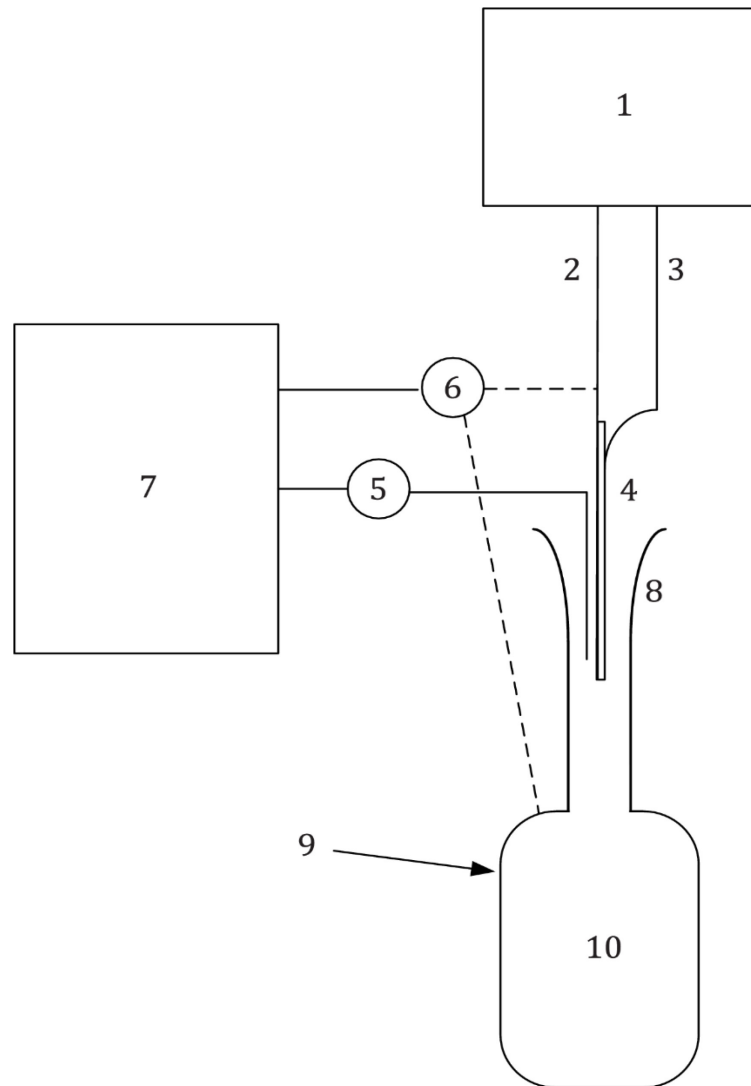

**Key**

- 1 ventilator under test
- 2 breathing circuit tubing
- 3 pressure measuring line, if applicable
- 4 airway device (tracheal tube, see Table 201.105)
- 5 pressure sensor, with a 10 % to 90 % rise time of no greater than 5 ms (only required for tests measuring airway pressure)
- 6 oxygen sensor (connected to the gas supply to airway device or to the test lung shown as dotted lines and only required for tests measuring oxygen concentration)
- 7 data acquisition system, with a minimum sample rate of 1 000 samples/s
- 8 patient airway model
- 9 test lung
- 10 test lung compliance ( $C_{lung}$ )

NOTE The tube between the pressure sensor and the Y-piece is selected so as to minimize its influence on pressure measurement (e.g. the frequency dependent transfer function).

The model of the patient airway is chosen to be appropriate to the intended use and patient population.

**Figure 201.103 — Performance test setup for an HFV without a patient-connection port**



**Table 201.104 — Test conditions for mean airway pressure and other tests**

Ideal body mass kg	HFV set rate inflations/s	I:E ratio <sup>a</sup>	Pressure amplitude <sup>b</sup> hPa	HFV volume <sup>b</sup> ml	Mean airway pressure <sup>c</sup> hPa	Mean airway pressure limit <sup>c</sup> hPa	O <sub>2</sub> %	Tube diameter <sup>d</sup> mm	Test lung	
									Compliance ml hPa <sup>-1</sup>	Resistance hPa(l/s) <sup>-1</sup>
0,4	15	1:1	15,0	1	10	20	30	2,5	0,5	20,0
3,5	15	1:1	30,0	4	10	20	60	3,0	1,0	10,0
8,0	10	1:1	50,0	12	15	30	30	3,5	3,0	5,0
45,0	10	1:1	50,0	30	20	40	60	5,0	20,0	5,0
60,0	5	1:1	70,0	120	25	50	30	7,0	50,0	2,0
80,0	5	1:1	70,0	200	35	60	60	9,0	50,0	2,0

a Set to the nearest available setting, if applicable.

b If provided, set the ventilator to the nearest available settings to achieve the specified pressure amplitude, or the specified HFV volume, as appropriate to the capability of the ventilator.

c If applicable, for some ventilators mean airway pressure is a consequence of other settings and patient characteristics and not directly set.

d Tube diameter applies only to an HFV that uses a patient-connection port. See Table 201.105.

**Table 201.105 — Tracheal tube parameters for HFV performance tests**

Nominal size	Internal diameter mm	Length mm	Radius of curvature mm
2,5	2,5	140 ± 10	70 ± 20
3,0	3,0	160 ± 10	80 ± 20
3,5	3,5	180 ± 10	90 ± 20
5,0	5,0	240 ± 10	120 ± 20
7,0	7,0	300 ± 10	140 ± 20
9,0	9,0	320 ± 10	140 ± 20

**201.12.1.102 Mean airway pressure limiting means for an HFV without a patient-connection port**

- a) An HFV not intended for use with a patient-connection port shall be equipped with a mean airway pressure limiting means.
- b) The mean airway pressure limiting means shall be:
- 1) pre-set by the manufacturer; or
  - 2) settable by the operator.
- c) The accuracy of this mean airway pressure limiting means as determined by the test and conditions specified in this document shall be disclosed in the instructions for use, as the maximum bias error and maximum linearity error.

EXAMPLE ± [3,0 +(5 % of the set pressure)] hPa

- d) The accuracy of the *mean airway pressure* limiting means shall be determined for the worst-case:
- 1) *HFV breathing system* configuration; and
  - 2) *airway device*.

Check conformance by the following tests:

- e) Set up the ventilator as shown in Figure 201.103 using the worst-case *HFV breathing system*.
- f) Utilize the test conditions for the first applicable row available on the ventilator (selected by intended patient weight range) in Table 201.104.
- g) Wait until equilibrium is reached in the mean airway pressure and pressure amplitude.
- h) Using the data acquisition system, measure the mean airway pressure for 60 s.
- i) At a time  $15\text{ s} \pm 5\text{ s}$  after starting recording, occlude the model upper airway. Continue to record the averaged airway pressure for a total of 60 s.
- j) Confirm that the measured mean airway pressure does not exceed the value disclosed in the instructions for use.
- k) Repeat f) to j) for each applicable row (selected by intended patient weight range) in Table 104.

#### **201.12.1.103 FiO<sub>2</sub> concentration**

- a) For an *HFV* equipped with FiO<sub>2</sub> concentration control, with the *high-frequency ventilator* operating in *normal condition*, the accuracy as determined for the test settings and conditions specified in this document shall be disclosed in the *instructions for use*, as the maximum bias error and maximum linearity error.

EXAMPLE  $\pm [5,0 + (5\% \text{ of the FiO}_2)] \%$

- b) This disclosure shall include at least:
- 1) the maximum error of the FiO<sub>2</sub> in relation to the set value;
- c) The accuracy of the performance of the *ventilator* shall either be:
- 1) determined for each *HFV breathing system* configuration indicated in the *instructions for use*; or
  - 2) determined for the worst-case *HFV breathing system* configurations indicated in the *instructions for use*.

NOTE The worst-case *HFV breathing system* configuration can be different for each error or *nominal* intended *patient* body weight.

- d) If worst-case *HFV breathing system* configurations are used, the rationale for their selection shall be documented in the *risk management file*.

Check conformance by inspection of the risk management file for the rationale, if applicable, and with the following tests:

- e) Set up the ventilator as shown in Figure 201.102 (for an HFV with a patient-connection port) or Figure 201.103 (for an HFV without a patient-connection port) using the worst-case HFV breathing system or using the maximum internal volume HFV breathing system. If the HFV breathing system includes a humidifier, use the minimum humidifier water level indicated in the instructions for use.
- f) Utilize the test conditions for the first applicable row available on the ventilator (selected by intended patient weight range) in Table 201.104.
- g) Wait until equilibrium is reached in the delivered oxygen concentration.
- h) Using the data acquisition system, measure the oxygen concentration for a duration of 10 s and calculate the delivered  $FiO_2$  as the average value of the measured oxygen concentration samples.
- i) Repeat g) to h) for each applicable row (selected by intended patient weight range) in Table 201.104.
- j) Repeat g) to h) with the maximum humidifier water level indicated in the instructions for use.

#### **201.12.1.104 \* Response of the ventilator to an increase in set $O_2$ concentration**

- a) For an HFV equipped with  $FiO_2$  concentration control, the length of time required for the oxygen concentration in the HFV volume to change from a volume fraction of oxygen of 21 % to a volume fraction of 90 % of the maximum achievable volume fraction of oxygen shall be disclosed in the instructions for use.
- b) The worst-case input oxygen concentration within the *rated* range shall be utilized for this test.
- c) The time shall be reported separately, as appropriate, for the *patient* weight ranges of:
  - 1) *patient* weight  $\leq 8$  kg;
  - 2)  $8 \text{ kg} \leq \textit{patient weight} \leq 45$  kg; and
  - 3) *patient* weight  $\geq 45$  kg;
 using:
  - 4) the worst-case HFV breathing system; or
  - 5) the maximum internal volume HFV breathing system; and
- d) The time may be reported separately for:
  - 1) each HFV breathing system; or
  - 2) as a maximum (for the worst-case HFV breathing system and minimum HFV volume).

*Check conformance with the following tests:*

- e) *Set up the ventilator as shown in Figure 201.104 for an HFV with a patient-connection port or Figure 201.105 for an HFV without a patient-connection port using the worst-case HFV breathing system or using the maximum internal volume HFV breathing system. If the HFV breathing system includes a humidifier, use the minimum humidifier water level indicated in the instructions for use.*

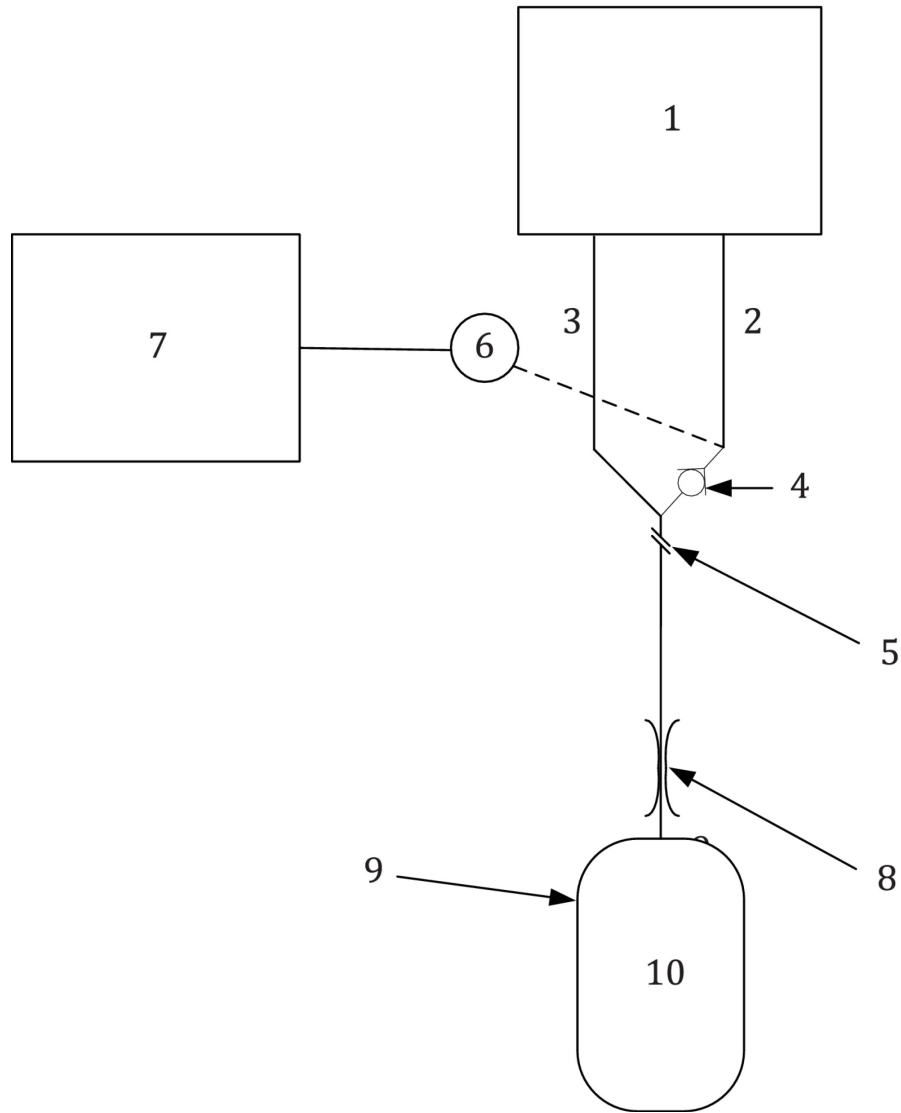

### Key

- 1 ventilator under test
- 2 breathing circuit tubing – inspiratory
- 3 breathing circuit tubing – expiratory
- 4 check valve to prevent return of mixed gas from the test lung to the oxygen sampling site
- 5 patient-connection port
- 6 oxygen sensor, with a 10% to 90% rise time not exceeding 25% of the  $\text{FiO}_2$  response time disclosed in the ventilator instructions for use
- 7 data acquisition system, with a minimum sample rate of 1 sample/s
- 8 resistance
- 9 test lung
- 10 test lung compliance ( $C_{\text{lung}}$ )

NOTE Depending on the operating mechanism of the HFV under test, it can be necessary to move the oxygen sampling site or the check valve to allow for measurement of the  $\text{FiO}_2$  at the ventilator outlet without the test measurement being impacted by the residual gas in the test lung.

**Figure 201.104 — Oxygen response test setup for an HFV with a patient-connection port**

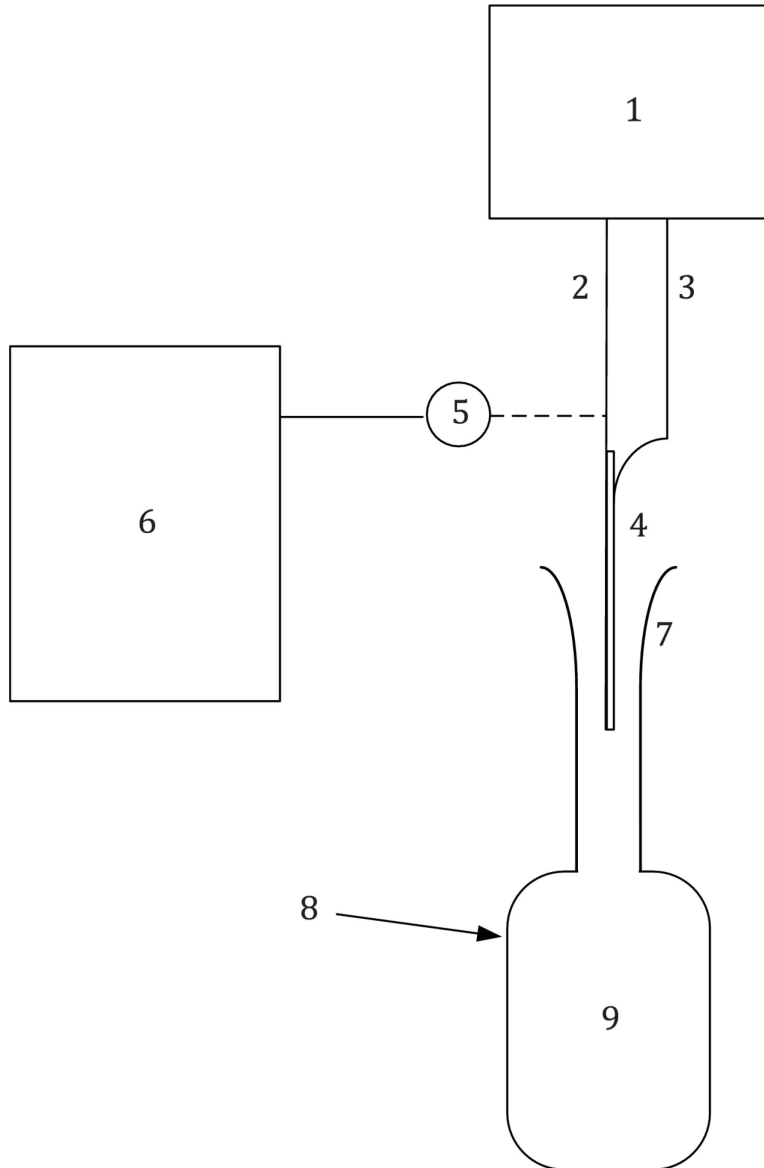

**Key**

- 1 ventilator under test
- 2 breathing circuit tubing
- 3 pressure measuring line, if applicable
- 4 airway device (tracheal tube, see Table 201.105)
- 5 oxygen sensor, with a 10% to 90% rise time not exceeding 25% of the  $\text{FiO}_2$  response time disclosed in the ventilator instructions for use
- 6 data acquisition system, with a minimum sample rate of 1 000 samples/s
- 7 patient airway model
- 8 test lung
- 9 test lung compliance ( $C_{\text{lung}}$ )

NOTE It is not in general practicable to measure the  $\text{FiO}_2$  downstream of the distal opening of the catheter used for high frequency ventilation due to entrainment of ambient air.

The model of the patient airway is chosen to be appropriate to the intended use and patient population.

**Figure 201.105 — Oxygen response test setup for an HFV without a patient-connection port**

- f) Utilize the test conditions for the first applicable row available on the ventilator (selected by intended patient weight range) in Table 201.104.
- g) Ventilate the test lung with a set oxygen concentration of 21 % volume fraction.
- h) Wait until equilibrium is reached in the inspired oxygen concentration at the oxygen measurement site.
- i) Change the set oxygen concentration to the maximum volume fraction that the ventilator permits.
- j) Measure the time delay between setting the new concentration and achieving 90 % of the final oxygen concentration during inspiration at the oxygen measurement site.
- k) Ensure that the measured time delay is less than or equal to that indicated in the instructions for use.
- l) Repeat g) to k) for each applicable column (selected by intended patient weight range) in Table 201.104.

#### **201.12.4 Protection against hazardous output**

*Addition:*

##### **201.12.4.101 Oxygen monitor**

- a) The ventilator shall either
  - 1) be equipped with O<sub>2</sub> monitoring equipment for the measurement of the inspiratory oxygen concentration (e.g., in the inspiratory limb or at the *patient-connection port*), that is integral to the ventilator; or
  - 2) the *instructions for use* shall contain a statement to the effect that the ventilator is to be equipped with O<sub>2</sub> monitoring equipment for measurement of the inspiratory oxygen concentration (e.g., in the inspiratory limb or at the *patient-connection port*) and conforming with ISO 80601-2-55:2018 before being put into service.
- b) Integrated O<sub>2</sub> monitoring equipment shall conform with the following subclauses of ISO 80601-2-55:2018:
  - 1) 201.7.4.3;
  - 2) 201.7.9.2.9.101 i), k) and n) ;
  - 3) 201.12.1.101;
  - 4) 201.12.1.102;
  - 5) 201.12.1.103;
  - 6) 208.6.1.2.

- c) Where the *O<sub>2</sub> monitoring equipment* is not an integral part of the *ventilator*, the *instructions for use* shall include the following:
  - 1) a statement to the effect that the *ventilator* is to be provided with *O<sub>2</sub> monitoring equipment* that conforms with ISO 80601-2-55:2018 before being put into service; and
  - 2) information on where to connect the *O<sub>2</sub> monitoring equipment*.
- d) The *O<sub>2</sub> monitoring equipment* shall, in addition, be equipped with an *alarm system* that includes a high oxygen level *alarm condition*.
- e) The high oxygen level *alarm condition*:
  - 1) shall be at least *medium priority*; unless
  - 2) an *intelligent alarm system*, based on additional information, determines that the high oxygen level *alarm condition* is suppressed or its priority is changed.

NOTE A low oxygen level *alarm condition* is required by ISO 80601-2-55.

*Check conformance by inspection of the instructions for use or application of the tests of ISO 80601-2-55:2018.*

#### **201.12.4.102 \* Measurement of *mean airway pressure* and low and high *mean airway pressure alarm conditions***

For an *HFV* with a *patient-connection port*,

- a) the *ventilator* shall be equipped with *monitoring equipment* to indicate the *mean airway pressure*.
- b) the site of actual measurement:
  - 1) may be anywhere in the *HFV breathing system*; but
  - 2) the indicated value shall be referenced to the *patient-connection port*.
- c) the accuracy of the measurement of the *mean airway pressure* shall be disclosed in the *instructions for use*.
- d) the *mean airway pressure monitoring equipment* shall be equipped with an *alarm system* to indicate when:
  - 1) the low *mean airway pressure alarm limit* is reached; and
  - 2) the high *mean airway pressure alarm limit* is reached.
- e) the low *mean airway pressure alarm condition*:
  - 1) shall be at least *medium priority*; unless
  - 2) an *intelligent alarm system*, based on additional information, determines that the low *mean airway pressure alarm condition* is suppressed or its priority is changed.



- f) the high *mean airway pressure alarm condition*:
- 1) shall be at least *high priority*; unless
  - 2) an *intelligent alarm system*, based on additional information, determines that the high *mean airway pressure alarm condition* is suppressed or its priority is changed.

Check conformance with the following.

- g) Set up the ventilator as shown in Figure 201.102 for an HFV with a patient-connection port or Figure 201.103 for an HFV without a patient-connection port using the worst-case HFV breathing system or using the maximum internal volume HFV breathing system. If the HFV breathing system includes a humidifier, use the minimum humidifier water level indicated in the instructions for use.
- h) Wait until equilibrium is reached at the patient-connection port.
- i) Utilize the test parameters and settings of the first applicable row (selected by typical intended patient weight) of Table 201.104.
- j) Wait until steady-state conditions are achieved.
- k) Measure the airway pressure for at least 10 s.
- l) Calculate mean airway pressure as the average value of all samples during the data acquisition period.
- m) Repeat i) to l) for each applicable row (selected by intended patient weight).
- n) Compare for all applicable rows, the mean airway pressure displayed by the ventilator with the mean airway pressure measured externally corrected by the measurement uncertainty.
- o) Check whether for all applicable rows the measured mean airway pressure is within the limits indicated in the instructions for use.

#### **201.12.4.103 Measurement of mean airway pressure at the distal outlet of the jet system and high mean airway pressure alarm condition**

For an HFV without a patient-connection port,

- a) the ventilator shall be equipped with monitoring equipment to indicate the *mean airway pressure*.
- b) the *mean airway pressure* measurement shall be referenced to the trachea (e.g. close vicinity of the distal outlet of the jet system).
- c) the accuracy of the measurement of the *mean airway pressure* shall be disclosed in the instructions for use.
- d) the *mean airway pressure monitoring equipment* shall be equipped with an *alarm system* to indicate when the high *mean airway pressure alarm limit* is reached.
- e) the high *mean airway pressure alarm condition*:
  - 1) shall be *high priority*; unless

- 2) an *intelligent alarm system*, based on additional information, determines that the high *mean airway pressure alarm condition* is suppressed or its priority is changed.

Check conformance with the following.

- f) Set up the HFV as shown in Figure 201.103 using the worst-case HFV breathing system or using the maximum internal volume HFV breathing system. If the HFV breathing system includes a humidifier, use the minimum humidifier water level indicated in the instructions for use.
- g) Utilize the test parameters and settings of the first applicable row (selected by typical intended patient weight) of Table 201.104.
- h) Wait until steady-state conditions are achieved.
- i) Measure the airway pressure for at least 10 s.
- j) Calculate mean airway pressure as the average value of all samples during the data acquisition period.
- k) Repeat g) to j) for each applicable row (selected by intended patient weight).
- l) Compare for all applicable rows, the mean airway pressure displayed by the HFV with the mean airway pressure measured externally corrected by the measurement uncertainty.
- m) Confirm that for all applicable rows the measured mean airway pressure is within the limits indicated in the instructions for use.

#### **201.12.4.104 Measurement of *pressure amplitude* and low and high *pressure amplitude alarm conditions***

- a) The ventilator should be equipped with *monitoring equipment* to indicate the *pressure amplitude*.
- b) If so equipped:
  - 1) the site of actual measurement:
    - i) may be anywhere:
      - I) in the *HFV breathing system*; or
      - II) in the *ventilator*; but
    - ii) the referenced point for indicated *pressure amplitude* shall be:
      - I) the *patient-connection port*, if so equipped; or
      - II) the distal outlet of the jet system.
  - 2) the algorithm determining the *pressure amplitude* shall be referenced against *HFV inflations* for a period of no greater than 10 s.
  - 3) the accuracy of the measured *pressure amplitude* under steady-state conditions shall be disclosed in the *instructions for use*.
  - 4) the *pressure amplitude monitoring equipment* shall be equipped with an *alarm system* to indicate when the low *pressure amplitude alarm limit* is reached.

- 5) the *pressure amplitude monitoring equipment* shall be equipped with an *alarm system* to indicate when the *high pressure amplitude alarm limit* is reached.
- 6) the *low pressure amplitude alarm condition* and the *high pressure amplitude alarm condition*:
  - i) shall be at least *medium priority*; unless
  - ii) an *intelligent alarm system*, based on additional information, determines that the *low pressure amplitude* or the *high pressure amplitude alarm condition* is suppressed or its priority is changed.

Check conformance with the following.

- c) Set up the ventilator as shown in Figure 201.102 (for a ventilator with a patient-connection port) or Figure 201.103 (for a ventilator without a patient-connection port) using the worst-case HFV breathing system. If the HFV breathing system includes a humidifier, use the minimum humidifier water level indicated in the instructions for use.
- d) Utilize the test parameters and settings of the first applicable row (selected by typical intended patient weight) of Table 201.104. Wait until steady-state conditions are achieved.
- e) Measure the airway pressure for at least 10 s.
- f) Calculate the pressure amplitude for each HFV inflation cycle as the difference between the maximum pressure value and the minimum pressure value of all samples during the period of that HFV inflation cycle.
- g) Calculate the pressure amplitude as the average pressure amplitude for all HFV inflation cycles within the 10s measurement period.
- h) Confirm that the measured pressure amplitude is within the limits indicated in the instructions for use.
- i) Repeat d) to h) for each applicable row (selected by intended patient weight).
- j) Repeat c) to i) for each applicable row (selected by intended patient weight).

#### **201.12.4.105 Measurement of HFV volume and low and high HFV volume alarm condition**

- a) If the ventilator is not equipped with *pressure amplitude monitoring equipment* according to 201.12.4.104, the ventilator shall be equipped with *monitoring equipment* to indicate the *HFV volume*.
- b) If so equipped
  - 1) the algorithm determining the *HFV volume* shall be referenced against *HFV inflations* for a period of no greater than 10 s.
  - 2) the *HFV volume* may be indicated as a flowrate in l/min.
  - 3) the accuracy of the measured *HFV volume* under steady-state conditions shall be disclosed in the *instructions for use*.
  - 4) the *technical description* shall disclose the test method for determining the *HFV volume*.

- c) If provided, the *HFV volume monitoring equipment* shall be equipped with an *alarm system* to indicate when:
- 1) the low *HFV volume alarm limit* is reached; and
  - 2) the high *HFV volume alarm limit* is reached.
  - 3) The low *HFV volume alarm condition* and the high *HFV volume alarm condition*:
    - i) shall be at least *medium priority*; unless
    - ii) an *intelligent alarm system*, based on additional information, determines that the low *HFV volume alarm condition* or the high *HFV volume alarm condition* is:
      - I) suppressed; or
      - II) its priority is changed.

*Check conformance by inspection of the instructions for use and technical description, inspection of the risk management file for the rationale, if applicable, and with the tests described in the technical description.*

#### **201.12.4.106 \* Maximum limited pressure protection device**

For an *HFV* equipped with a *patient-connection port*

- d) a *protection device* shall be provided to prevent the *airway pressure* from exceeding the *maximum limited pressure* under both:
- 4) *normal condition*; and
  - 5) *single fault condition*.
- e) the *maximum limited pressure* shall not exceed 125 hPa (125 cmH<sub>2</sub>O).
- f) when operating in a conventional *ventilation-mode*, the means of protection shall take effect within a maximum of 200 ms following the *airway pressure* exceeding the *maximum limited pressure*.
- g) When operating in a high-frequency *ventilation-mode*, the means of protection shall be initiated when the *mean airway pressure* (averaged over a duration of no longer than 200 ms) reaches the *maximum limited pressure*.

*Check conformance by functional testing.*

#### **201.12.4.107 \* High-pressure protection device**

For an *HFV* not equipped with a *patient-connection port* and operating in a high-frequency *ventilation-mode*,

- a) a *protection device* shall be provided to prevent the tracheal pressure from exceeding a maximum pressure under both:
- 1) *normal condition*; and
  - 2) *single fault condition*.
- b) the maximum pressure shall not exceed 125 hPa (125 cmH<sub>2</sub>O).

*Check conformance by functional testing.*

#### **201.12.4.108 Obstruction alarm condition**

- a) The *ventilator* shall be equipped with *monitoring equipment* with an *alarm system* that detects a *technical alarm condition* to indicate when the *alarm limit* for obstruction is reached.

EXAMPLE *Alarm condition* to warn of:

- an obstructed inspiratory or expiratory breathing tube,
- a blocked exhalation valve, or
- a blocked expiratory *breathing system filter*.

NOTE The obstruction *alarm condition* is not applicable to obstruction of tracheal tubes. Obstruction of the tracheal tube can be detected e.g. by the *alarm conditions* specified in 201.12.4.103 to in 201.12.4.105.

- b) The obstruction *alarm condition* shall be *high priority*, unless an *intelligent alarm system*, based on additional information, determines that the obstruction *technical alarm condition*:
- 1) is suppressed; or
  - 2) its priority is changed.
- c) The *alarm condition delay* shall not exceed 5 s.
- d) The means by which the obstruction *alarm condition* is determined and a means to test it shall be described in the *accompanying document*.

*Check conformance by functional testing with each HFV breathing system indicated in the instructions for use, according to the test method described in the accompanying document.*

#### **201.12.4.109 \* Disconnection alarm condition**

- a) The *ventilator* shall be equipped with an *alarm system* that detects a *technical alarm condition* to indicate when conditions in the *HFV breathing system* reach the *alarm limit* for disconnection.

EXAMPLE An *alarm condition* to warn of

- disconnection of the inspiratory or expiratory breathing tube, or
- disconnection at the *patient-connection port*.

NOTE For the purposes of this document, extubation is not considered disconnection.

- b) The disconnection *technical alarm condition* shall be at least *medium priority*.
- c) The *alarm off* of the disconnection *technical alarm condition alarm signals* shall not be provided when the *ventilator* is operating in a *ventilator operational mode* intended for a *ventilator-dependent patient*.
- 1) A local *alarm off* may be provided when the *ventilator* is connected to a *distributed alarm system*.
- d) The *alarm off* of the disconnection *technical alarm condition alarm signals* may be provided when the *ventilator* is operating in any *ventilator operational mode* not intended for a *ventilator-dependent patient*.
- 1) The *instructions for use* shall disclose the circumstances in which the *HFV* is intended for use with a *non-ventilator-dependent patient*.

- e) The *instructions for use* shall disclose the maximum *alarm condition delay* of the disconnection *technical alarm condition*.

*Check conformance by functional testing and inspection of the instructions for use.*

#### **201.12.4.110 Minimum limited pressure protection device**

- a) For an *HFV* capable of generating subatmospheric pressure at the *patient-connection port* a *protection device* shall be provided to prevent the *airway pressure* from falling below the *minimum limited pressure* under both:
- 1) *normal condition*; and
  - 2) *single fault condition*.
- b) When operating in a high-frequency *ventilation-mode*, the means of protection shall be initiated when the *mean airway pressure* (averaged over a duration of no longer than 200 ms) reaches the *minimum limited pressure*.

*Check conformance by functional testing.*

#### **201.12.101\* Protection against accidental or unintentional adjustments**

- a) The *ventilator* shall include a means for the *healthcare professional operator* to confirm the *ventilator operational-mode* and settings:
- 1) during the start-up *procedure*; and
  - 2) when the *ventilator operational-mode* is changed during use.
- b) Means of protection against accidental or unintentional adjustment of controls that can create a *hazardous situation*, including against accidentally turning the *ventilator* off, shall be provided.
- c) The *usability* of these means of protection shall be evaluated in the *usability engineering process*.

NOTE The requirements for the *usability engineering process* are found in 12.2 of IEC 60601-1:2005+AMD1:2012+AMD2:2020 and IEC 60601-1-6:2010+AMD1:2013+AMD2:2020.

*Check conformance by functional testing and inspection of the usability engineering file.*

#### **201.13 Hazardous situations and fault conditions for ME equipment**

Clause 13 of IEC 60601-1:2005+AMD1:2012+AMD2:2020 applies, except as follows:

*Addition:*

##### **201.13.101\* Additional specific single fault conditions**

A *ventilator* shall be so designed and constructed that the following *single fault conditions* shall not cause an unacceptable *risk*:

- a) \* disruption of the gas delivery to the *patient-connection port* or at the distal outlet of the jet system from the *ventilator*;

- b) \* when present, disruption of the gas flow pathway from the *patient-connection port* or at the distal outlet of the jet system to the *ventilator*;
- c) \* removal or failure of a *healthcare professional operator-detachable breathing system filter*; and
- d) \* disruption of a *functional connection* between parts of the *ventilator* or *ME system*.

EXAMPLE 1 Loss of communication between the *ventilator* and its remote (wired or wireless) control or monitoring module.

EXAMPLE 2 Loss of communication between the *ventilator* and its *distributed alarm system*.

EXAMPLE 3 Loss of communication between the *ventilator* and the means for generating remote *alarm signals*.

*Check conformance by functional testing and inspection of the risk management file.*

### **201.13.102\* Failure of one gas supply to a ventilator**

- a) Following the failure of one gas supply, a *ventilator* with two pressurized gas supplies shall automatically use the remaining gas supply, and otherwise maintain normal operation other than delivered oxygen concentration.
- b) The *ventilator* shall be equipped with an *alarm system* that detects a *technical alarm condition* to indicate this gas supply failure.
- c) The gas supply failure *technical alarm condition*:
  - 1) shall be at least *low priority*; unless
  - 2) an *intelligent alarm system*, based on additional information, determines that the gas supply failure *technical alarm condition* is suppressed.

*Check conformance by functional testing.*

### **201.13.103\* Independence of ventilation control function and related risk control measures**

- a) A *single fault condition* shall not cause the simultaneous failure of:
  - 1) the *ventilation control function*; and
  - 2) the corresponding *protection device*.
- b) A *single fault condition* shall not cause either:
  - 1) a *ventilation control function* and the corresponding *monitoring equipment*; or
  - 2) a *ventilation control function* and the corresponding *alarm system*

to fail in such a way that the loss of the *ventilation control function* is not detected.

*Check conformance by inspection and functional testing.*

### **201.13.104\* Failure of a *functional connection* to a *ventilator* control or monitoring means**

- a) Following the failure of a *functional connection* to a *ventilator* control or monitoring means, the *ventilator* shall continue to ventilate the *patient*.
- b) The *ventilator* shall be equipped with an *alarm system* that detects a *technical alarm condition* to indicate this communication failure.
- c) The communication failure *technical alarm condition*:
  - 1) shall be at least *medium priority*; unless
  - 2) an *intelligent alarm system*, based on additional information, determines that the communication failure *technical alarm condition*:
    - i) is suppressed; or
    - ii) the priority is changed.

*Check conformance by functional testing.*

### **201.14 Programmable electrical medical systems (PEMS)**

Clause 14 of IEC 60601-1:2005+AMD1:2012+AMD2:2020 applies, except as follows:

*Addition:*

#### **201.14.101 Software life cycle**

- a) The *programmable electronic subsystems (PESS)* of a *ventilator* shall be developed with a design *process* conforming with IEC 62304:2006+AMD1:2015.
- b) The *ventilation control software items* of the *ventilator PESS* without an independent *risk control* measure external to the *PESS* shall be considered as software safety Class C.

*Check conformance by inspection of the documentation required by 4.3 of IEC 62304:2006+AMD1:2015 for the software safety class.*

### **201.15 Construction of ME equipment**

Clause 15 of IEC 60601-1:2005+AMD1:2012+AMD2:2020 applies, except as follows:

*Addition:*

#### **201.15.3.5.101 Additional requirements for rough handling**

##### **201.15.3.5.101.1 \* Shock and vibration (robustness)**

- a) A *ventilator* and its parts, including applicable *accessories*, shall have adequate mechanical strength when subjected to mechanical stress caused by *normal use*, pushing, impact, dropping and rough handling.
- b) *Stationary ME equipment* is exempt from the requirements of this subclause.
- c) After the following tests, the *ventilator* shall:
  - 1) maintain *basic safety* and *essential performance*; and



- 2) conform with the requirements of 201.12.1 and 201.12.4.

NOTE A ventilator tested and conforming with a more severe requirement is considered to conform with the corresponding requirement of this subclause.

*Check conformance by performing the following tests:*

- d) *Shock test in conformance with IEC 60068-2-27:2008, using the following conditions:*

NOTE This represents IEC/TR 60721-4-7:2001 <sup>[33]</sup>, Class 7M2.

- 1) *test type: Type 1,*

- *peak acceleration: 150 m/s<sup>2</sup> (15 g);*
- *duration: 11 ms;*
- *pulse shape: half-sine;*
- *number of shocks: 3 shocks per direction per axis (18 total);*

or

- 2) *test type: Type 2,*

- *peak acceleration: 300 m/s<sup>2</sup> (30 g);*
- *duration: 6 ms;*
- *pulse shape: half-sine;*
- *number of shocks: 3 shocks per direction per axis (18 total);*

- e) *Broadband random vibration test in conformance with IEC 60068-2-64:2008, using the following conditions:*

NOTE3 This represents IEC/TR 60721-4-7:2001 <sup>[33]</sup>, Classes 7M1 and 7M2, modified.

- 1) *acceleration amplitude:*

- *10 Hz to 100 Hz: 1,0 (m/s<sup>2</sup>)<sup>2</sup>/Hz;*
- *100 Hz to 500 Hz: -6 db per octave;*

- 2) *duration: 10 min per perpendicular axis (3 total).*

- f) *Confirm that basic safety and essential performance and the requirements of 201.12.1 and 201.12.4 are maintained following the tests.*

**201.15.3.5.101.2 \* Shock and vibration for a *transit-operable ventilator* during operation**

- a) A *ventilator* and its parts, including applicable *accessories*, intended for *transit-operable* use during *patient* transport inside a healthcare facility shall have adequate mechanical strength when subjected to mechanical stress caused by *normal use*, pushing, impact, dropping and rough handling while operating.
- b) For this test, the *ventilator* and its parts, and applicable *accessories*, shall be mounted using the mounting *accessories* indicated in the *accompanying documents*.

NOTE 1 If more than one mounting system is described in the *accompanying documents*, multiple tests are required.

NOTE 2 A *ventilator* tested and conforming with a more severe requirement is considered to conform with the corresponding requirement of this subclause.

- c) During the following tests, a *ventilator* shall maintain *basic safety* and *essential performance* while ventilating a test lung using the worst-case conditions and parameters of Table 201.102, selected by intended *patient* weight, as appropriate.
- d) During the testing, the error of:
- 1) the *mean airway pressure* averaged over 10 s shall not deviate by more than 5 hPa or 25 % of the *mean airway pressure* measured prior to the test, whichever is greater;
  - 2) the *HFV volume* averaged over 1 minute shall not deviate by more than 25 % of the *HFV volume* measured prior to the test; and
  - 3) For an *HFV* equipped with  $\text{FiO}_2$  concentration control, the delivered  $\text{FiO}_2$  averaged over a one min interval shall not deviate by more than the deviation disclosed by the *manufacturer* in the *instructions for use*.

Check conformance by performing the following tests:

- e) Shock test in conformance with IEC 60068-2-27:2008, using the following conditions:
- 1) test type: Type 1,
    - peak acceleration: 50 m/s<sup>2</sup> (5 g);
    - duration: 6 ms;
    - pulse shape: half-sine;
    - number of shocks: 3 shocks per direction per axis (18 total).
- f) Broadband random vibration test in conformance with IEC 60068-2-64:2008, using the following conditions:
- 1) acceleration amplitude:
    - 10 Hz to 100 Hz: 0,33 (m/s<sup>2</sup>)<sup>2</sup>/Hz;
    - 100 Hz to 500 Hz: -6 db per octave;

2) *duration: 30 min per perpendicular axis (3 total).*

g) *Free fall in conformance with IEC 60068-2-31:2008, using Procedure 1 and the following conditions:*

1) *fall height:*

— *for mass  $\leq 1$  kg, 0,25 m*

— *for mass  $> 1$  kg and  $\leq 10$  kg, 0,1 m*

— *for mass  $> 10$  kg and  $\leq 50$  kg, 0,05 m*

— *for mass  $> 50$  kg, 0,01 m*

2) *number of falls: 2 in each specified attitude.*

h) *Confirm that during these tests:*

1) *basic safety is maintained; and*

2) *the mean airway pressure, HFV volume and the delivered  $FiO_2$  are within the indicated limits during the tests.*

#### **201.15.4.1 Construction of connectors**

*Addition:*

aa) *Healthcare professional operator-detachable gas pathway connectors are exempt from this requirement.*

#### **201.15.101 Mode of operation**

*A ventilator shall be suitable for continuous operation.*

*Check conformance by inspection.*

#### **201.15.102 Delivered oxygen concentration**

*A ventilator shall be capable of supplying gas to the patient containing an  $O_2$  concentration over the range from ambient to at least 95 % of the input oxygen concentration.*

*Check conformance by functional testing.*

#### **201.15.103 Accessory self-check**

a) *A ventilator shall be equipped with means that allow the determination of whether or not the HFV breathing system characteristics are outside the values necessary to maintain normal operation.*

EXAMPLE Leakage, resistance, compliance.

NOTE Additional requirements are found in 201.7.9.2.8.101.

b) *This means may require operator action.*

*Check conformance by functional testing.*

## **201.16 ME systems**

Clause 16 of IEC 60601-1:2005+AMD1:2012+AMD2:2020 applies, except as follows:

*Addition:*

### **201.16.1.101 Additional general requirements for ME systems**

*Accessories* connected to the *HFV breathing system* shall be considered to form an *ME system* with the *ventilator*.

*Check conformance by application of the relevant tests of IEC 60601-1:2005+AMD1:2012.*

## **201.17 Electromagnetic compatibility of ME equipment and ME systems**

Clause 17 of IEC 60601-1:2005+AMD1:2012+AMD2:2020 applies.

*Additional subclauses:*

### **201.101 Gas connections**

#### **201.101.1 \* Protection against reverse gas leakage**

For a *ventilator* with two *high-pressure inlets*,

- a) means shall be provided to limit reverse gas flowrate (leakage) from a *gas intake port* into the supply system of the same gas to less than 100 ml/min in *normal condition* or *single fault condition*.
- b) means shall be provided to limit cross leakage from gas supplied through one *high-pressure inlet* into the supply system of a different gas to less than 100 ml/h in *normal condition* or *single fault condition*.

*Check conformance by functional testing.*

#### **201.101.2 Connection to a high-pressure inlet**

##### **201.101.2.1 Connector**

If an *operator-detachable* hose assembly is provided for connection between the *ventilator* and either a *medical gas pipeline system* or a pressure regulator, it shall conform with ISO 5359:2014.

*Check conformance by application of the tests of ISO 5359:2014.*

##### **201.101.2.2 \* Filter**

Each *high-pressure inlet* shall be provided with a filter having a pore size less than or equal to 100 µm.

NOTE Depending on the sensitivity against particles of the components used in the *gas pathways* (e.g. flow sensors), to particles, filtration of smaller particles can be needed.

*Check conformance by inspection.*

### 201.101.3 *HFV breathing system connectors*

#### 201.101.3.1 \* General

*Operator-detachable HFV breathing system connections through which the main flow of gas to or from the patient passes in normal condition, excluding the patient-connection port:*

- a) shall be a 15 mm or a 22 mm connector conforming with ISO 5356-1:2015;
- b) may be a 11,5 mm connector conforming with ISO 5356-1:2015 for use in a neonatal or paediatric *HFV breathing system*; or
- c) may be a connector that does not engage with a conical connector conforming with ISO 5356-1:2015.

*Check conformance by application of the tests of ISO 5356-1:2015 and functional testing.*

#### 201.101.3.2 Other named ports

##### 201.101.3.2.1 *Patient-connection port*

The *patient-connection port*, if equipped, shall be one of the following:

- a) a female 15 mm conical connector conforming with ISO 5356-1:2015; or
- b) a coaxial 15 mm/22 mm conical connector conforming with ISO 5356-1:2015.

*Check conformance by application of the tests of ISO 5356-1:2015.*

##### 201.101.3.2.2 *Gas output port and gas return port*

- a) The *gas output port* and the *gas return port* shall be one of the following
  - 1) a male 22 mm conical connector conforming with ISO 5356-1:2015.
  - 2) a male 15 mm conical connector conforming with ISO 5356-1:2015.
  - 3) a coaxial 15 mm/22 mm conical connector conforming with ISO 5356-1:2015.
  - 4) a connector that does not engage with a conical connector conforming with ISO 5356-1:2015.
- b) Notwithstanding this requirement, a *ventilator* only intended for *patients* with a weight of  $\leq 8$  kg, may be equipped with a *gas output port* and a *gas return port* with a male 11,5 mm conical connector conforming with ISO 5356-1:2015.

*Check conformance by application of the tests of ISO 5356-1:2015.*

##### 201.101.3.2.3 *Emergency intake port*

- a) An *emergency intake port* shall not be equipped with an *operator-accessible connector*.
- b) An *emergency intake port* shall be designed to prevent obstruction when the *ventilator* is in use.

*Check conformance by inspection.*

#### **201.101.3.2.4 Flow-direction-sensitive components**

Any *flow-direction-sensitive component* of the *HFV breathing system* detachable without the use of a *tool* shall be so designed that it cannot be fitted in such a way that it presents an unacceptable *risk* to the *patient*.

*Check conformance by inspection of detachable flow-direction-sensitive components and inspection of the risk management file.*

#### **201.101.3.2.5 \* Accessory port**

If provided, each *accessory port* shall:

- a) conform with ISO 80369-1:2018;

NOTE It is expected that the RESP-125 connector of ISO 80369-2 [21] will meet this criterion.

- b) be provided with a means to secure the *accessory* in position; and

- c) be provided with a means to secure closure after removal of the *accessory*.

NOTE 1 This port connects to the *gas pathway* and is generally used for measuring pressure or for the introduction of therapeutic aerosols.

NOTE 2 For the purposes of this document, the temperature probe port specified in ISO 80601-2-74 is not considered an *accessory port*.

*Check conformance by inspection.*

#### **201.101.3.2.6 Gas exhaust port**

- a) If a connector is provided for the *gas exhaust port*, it shall be a 30 mm connector conforming with ISO 5356-1:2015.

NOTE A 30 mm connector conforming with ISO 5356-1:2015 is suitable for connection to an anaesthetic gas scavenging system (AGSS) that conforms with ISO 80601-2-13 [24] and ISO 7396-2 [5].

- b) A *ventilator* shall be designed so that any provided *gas exhaust port* is not obstructed during use.

*Check conformance by inspection and application of the tests of ISO 5356-1:2015.*

### **201.102 Requirements for the HFV breathing system and accessories**

#### **201.102.1 \* General**

All *HFV breathing systems*, their parts and *accessories* shall conform with the requirements of this document, whether they are produced by the *manufacturer* of the *HFV* or by another entity (“third-party manufacturer” or healthcare provider).

*Check conformance by the tests of this document.*

**201.102.2 Labelling**

- a) The *accompanying document* provided with each *HFV breathing system*, its parts or *accessories*, conforming with 201.102.1, shall include at least *model or type reference* of at least one compatible *HFV*.
- b) Statements shall be included in the *accompanying document* of each *HFV breathing system*, its parts or *accessories* to the effect that:
  - 1) breathing systems, their parts and accessories are validated for use with specific ventilators;
  - 2) incompatible parts can result in degraded performance; and
  - 3) the responsible organization is responsible for ensuring the compatibility of the ventilator and all of the parts used to connect to the patient before use.

*Check conformance by inspection of the accompanying document.*

**201.102.3 Breathing tubes**

Breathing tubes intended for use in an *HFV breathing system* shall conform with the following clauses and subclauses of ISO 5367:2014:

- a) 5.3.4; and
- b) Clause 6.

*Check conformance by application of the tests of ISO 5367:2014.*

**201.102.4 \* Water vapour management**

Any *humidifier*, including heated breathing tubes, either incorporated into the *ventilator* or recommended for use with the *ventilator*, shall conform with ISO 80601-2-74:—.

*Check conformance by application of the tests of ISO 80601-2-74:—.*

**201.102.5 Breathing system filters**

Any *breathing system filter*, either incorporated into the *ventilator* or recommended for use with the *ventilator*, shall conform with the relevant requirements of:

- a) ISO 23328-1:2003; and
- b) ISO 23328-2:2002.

*Check conformance by application of the tests of ISO 23328-1:2003 and ISO 23328-2:2002.*

**201.102.6 \* Leakage from the complete VBS**

For an *HFV* equipped with a *patient-connection port*, unintended leakage from the *VBS* should not exceed:

- a) 200 ml/min at 50 hPa (50 cmH<sub>2</sub>O) for a *ventilator* intended for a *patient* with a weight  $\geq 45$  kg;
- b) 100 ml/min at 40 hPa (40 cmH<sub>2</sub>O) for a *ventilator* intended for a *patient* with a weight, *between 8 kg  $\leq$  patient weight  $\leq$  45 kg; or*

- c) 50 ml/min at 20 hPa (20 cmH<sub>2</sub>O) for a *ventilator* intended for a *patient* with a weight  $\leq 8$  kg.

*Check conformance by functional testing.*

### **201.103 \* Spontaneous breathing during loss of power supply**

For an *HFV* equipped with a *patient-connection port*:

- a) a *protection device* shall be provided to allow spontaneous breathing when normal *ventilation* is compromised as a result of the electrical or pneumatic supply power being outside the values necessary for normal operation; and
- b) under these conditions, the inspiratory and expiratory pressure drop measured at the *patient-connection port* with all recommended *accessories* in place shall not exceed 6,0 hPa (6,0 cmH<sub>2</sub>O) at a flowrate of:
- 1) 30 l/min for a *ventilator* intended for a *patient* with a weight  $\geq 45$  kg;
  - 2) 15 l/min for a *ventilator* intended for a *patient* with a weight, *between*  $8$  kg  $\leq$  *patient* weight  $\leq 45$  kg;
  - 3) 2,5 l/min for a *ventilator* intended for a *patient* with a weight  $\leq 8$  kg.

NOTE This requirement is intended to allow the *patient* to breathe spontaneously under compromised conditions.

*Check conformance by functional testing and measurement of flowrate, pressure, and resistance at the patient-connection port with the combination of accessories indicated in the instructions for use that produces the highest pressure drop.*

### **201.104 \* Indication of duration of operation**

- a) The *ventilator* shall have means to indicate visually the cumulative hours of operation of the *ventilator*, either:
- 1) automatically; or
  - 2) by *operator* action.
- b) The *ventilator* should also have means to indicate visually:
- 1) the time since the last preventive maintenance; or
  - 2) the time until the next recommended preventive maintenance.

*Check conformance by inspection.*



## **201.105 Functional connection**

### **201.105.1 General**

*Basic safety and essential performance* shall be maintained if connections to a *functional connection* of a ventilator are:

- a) disrupted or
- b) if the equipment connected to those parts fails.

*Check conformance by functional testing.*

### **201.105.2 \* Connection to an electronic health record**

- a) A ventilator shall be equipped with a *functional connection* that permits data transmission from the ventilator to an electronic health record.
- b) The data transmission should be capable of transmitting the information described in Annex BB.

*Check conformance by inspection.*

### **201.105.3 \* Connection to a distributed alarm system**

A ventilator shall be equipped with a *functional connection* that permits connection to a *distributed alarm system*.

### **201.105.4 Connection for remote control**

A ventilator may be equipped with a *functional connection* for connection for external control of the ventilator.

NOTE AAMI 2700-1:2019 <sup>[36]</sup> and IEEE 11073-20701 <sup>[16]</sup> are examples of suitable standards for providing such a *functional connection*.

## **201.106 Display loops**

### **201.106.1 Pressure-volume loops**

- a) If a ventilator is provided with the display of pressure-volume loops, the graph shall use:
  - 1) volume on the vertical axis; and
  - 2) *airway pressure* on the horizontal axis.
- b) Positive values shall be on the top and the right of the display.
- c) Increases in volume shall be positive values.
- d) The volume shall be reset to the origin at the beginning of each breath.

*Check conformance by inspection.*

### 201.106.2 Flow-volume loops

- a) If a *ventilator* is provided with the display of flow-volume loops, the graph shall use:
  - 1) flowrate on the vertical axis; and
  - 2) volume on the horizontal axis.
- b) Positive values shall be on the top and the right of the display.
- c) Gas flow to the *patient* (inspiratory flow) and increases in volume shall be positive values.
- d) The volume shall be reset to the origin at the beginning of each breath.
- e) The *ventilator* may be provided with an additional optional display configuration for the flow-volume loop where gas flow from the *patient* (expiratory flow) is represented as a positive value.

*Check conformance by inspection.*

### 201.107 Timed high-frequency oscillation pause

- a) The *ventilator* may be equipped with an oscillation pause function.
- b) The maximum oscillation pause duration shall be:
  - 1) no greater than 60 s; and
  - 2) disclosed in the *instructions for use*.

NOTE This pause can be used to synchronize radiographic imaging with non-moving *lungs* or to implement a recruitment manoeuvre

*Check conformance by functional testing.*

## 202 Electromagnetic disturbances - Requirements and tests

IEC 60601-1-2:2014 applies except as follows:

### 202.4.3.1 \* Configurations

*Amendment (replace the second dash of 4.3.1 with):*

- the *ventilator* operated using the worst-case conditions and parameters of Table 201.102, selected by intended *patient* weight, as appropriate. During this testing, the *alarm limits* for the volume and pressure *alarm condition* shall be set to their least sensitive levels.

### 202.5.2.2.1 Requirements applicable to all *ME equipment* and *ME systems*

*Amendment [add note to list element b]):*

NOTE The requirements of this document are not considered deviations or allowances.

*Addition:*

**202.8.1.101 \* Additional general requirements**

- a) The following degradations, if associated with *basic safety* and *essential performance*, shall not be allowed:
- 1) component failures;
  - 2) changes in programmable parameters or settings;
  - 3) reset to default settings;
  - 4) change of operating *ventilator operational mode*; and  
     EXAMPLE   Change of *HFV inflation type, ventilation-mode, HFV frequency, I/E ratio*.
  - 5) initiation of an unintended operation.
- b) During the testing, the error of:
- 1) the *mean airway pressure* averaged over 10 s shall not deviate by more than 5 hPa or 25 % of the *mean airway pressure* measured prior to the test, whichever is greater; and
  - 2) the *HFV volume* averaged over 1 minute shall not deviate by more than 25 % of the *HFV volume* measured prior to the test; and
  - 3) the O<sub>2</sub> concentration averaged over 1 min shall not deviate more as 25% measured prior to the test.
- c) The *ventilator* may exhibit temporary degradation of performance (e.g. deviation from the performance indicated in the *instructions for use*) that does not affect *basic safety* or *essential performance*.

**206 Usability**

IEC 60601-1-6:2010+AMD1:2013 applies except as follows:

*Addition:*

**206.101 Primary operating functions**

- a) For a *ventilator*, the following shall be considered *primary operating functions*:
- 1) setting the *healthcare professional operator*-adjustable controls:
    - i) setting *alarm limits*;
    - ii) inactivating *alarm signals*;
    - iii) switching between different *ventilation-modes* and *HFV inflation types*; and
    - iv) setting *ventilation control parameters*;  
     EXAMPLE 1 *HFV frequency, mean airway pressure*
  - 2) observing and identifying the monitored *ventilation parameters*;  
     EXAMPLE 2   *Airway pressure and HFV volume*  
     EXAMPLE 3   FiO<sub>2</sub> (inspiratory oxygen concentration)

- 3) configuring
  - i) the *HFV breathing system* including
  - ii) connection of the detachable parts of the *HFV breathing system* to the *ventilator*;  
EXAMPLE 4 *Humidifier, water-trap, tubing, breathing system filter*
- 4) starting the *ventilator* from power off;
- 5) turning off the *ventilator*;
- 6) performing a basic pre-use functional check of the *ventilator* including the *alarm system*; and
- 7) *processing* the *ventilator* between *patient* uses.

b) The following functions, if available, also shall be considered *primary operating functions*:

- 1) starting *ventilation* from standby;
- 2) activating standby;
- 3) activating manoeuvres that help assess *lung* function or the effectiveness of *ventilator* parameter settings;

EXAMPLE 5 *Recruitment manoeuvre, oscillation pause*

- 4) activating a closed suctioning function;
- 5) connecting or disconnecting the *patient-connection port* of the *HFV breathing system* to the *airway device*;
- 6) positioning the *applied part* within the *patient's* airway, including positioning the distal outlet of the jet system;
- 7) observing respiratory gas concentrations; and

EXAMPLE 6  $\text{FiO}_2$

- 8) attaching the *ventilator* and, where applicable, the *HFV breathing system* to a trolley.

c) The following actions associated with *ventilation* also shall be considered *primary operating functions*:

NOTE For the purposes of this document, the following functions are considered *primary operating functions* even though they are not performed on the *ventilator's operator-equipment interface*.

- 1) humidifying/conditioning gases delivered through the *HFV breathing system*;
- 2) X-raying the *patient*;
- 3) providing alternative means of *ventilation* with a manual resuscitator;
- 4) positioning the *patient*; and

- 5) connecting and disconnecting a *distributed alarm system*.
- d) The following actions associated with *ventilation* also shall be considered *primary operating functions* unless they are contraindicated:

NOTE For the purposes of this document, the following functions are considered *primary operating functions* even though they are not performed on the *ventilator's operator-equipment interface*.

- 1) adding medication to the gas flowing into the *patient*;

EXAMPLE 7 Nebulisation or injecting fluids into the ancillary port connection of the *HFV breathing system*

- 2) suctioning the *patient's* airway;

### 206.102 \* Training

In the application of the requirements of 5.6 and 5.8 of IEC 62366-1:2015, training shall be considered necessary for both:

- a) the *healthcare professional operator*; and
- b) the designee of the *responsible organization* (e.g. *service personnel* or *processing personnel*).

NOTE Requirements for training are found in 5.6 and 5.8 of IEC 62366-1:2015.

*Check conformance by inspection of the accompanying document.*

## 208 General requirements, tests and guidance for *alarm systems in medical electrical equipment and medical electrical systems*

IEC 60601-1-8:2006+AMD1:2012 applies except as follows:

*Addition:*

### 208.6.3.2.2.101 Additional requirements for 1 m (*operator's position*) visual *alarm signals* and *information signals*

- a) *High priority alarm signals* should be accompanied by information describing possible causes of the *alarm condition* and appropriate actions to take in response.

EXAMPLE The obstruction alarm limit has been reached. Check the breathing system tubing for blockages or crimping. Check breathing system filters for blockage

- 1) *Operator* action may be required to display the information.

*Check conformance by inspection.*

### 208.6.8.3.101 Additional requirements for global indefinite *alarm signal* inactivation states

- a) A *ventilator* shall not be equipped with a means to initiate a global *alarm off* while connected to a *patient*.
- b) A *ventilator* shall not be equipped with a means to initiate a global *audio off* unless the *ventilator* is connected to a *distributed alarm system*.

*Check conformance by functional testing.*

**208.6.8.4.101 \* Additional requirements for termination of *alarm signal* inactivation**

The duration of *audio paused* of the *alarm conditions* required by this document shall not exceed 120 s without *healthcare professional operator* intervention.

NOTE This permits a *healthcare professional operator* to deliberately extend the duration of *audio paused* by direct action.

*Check conformance by functional testing.*

**208.6.12.101 \* Additional requirements for *alarm system* logging**

- a) Notwithstanding the requirements of IEC 60601-1-8:2006+AMD1:2012, the *ventilator* shall
- 1) be equipped with an *alarm system* log with a capacity of at least 1 000 events for all:
    - i) *high priority alarm conditions*;
    - ii) *medium priority alarm conditions*; and
    - iii) *alarm signal* inactivation states.
  - 2) time stamp all events according to 6.12 a) of IEC 60601-1-8:2006+AMD1:2012.
  - 3) not lose the contents of the *alarm system* log during a loss of power for less than 7 d unless the log is deleted by *responsible organization* action.
  - 4) not permit the *healthcare professional operator* to erase the contents of the *alarm system* log.
- b) This log should include at least the following events:
- 1) any change of *ventilator* settings, including the value applied;
  - 2) any change of *alarm settings*, including the value applied;
  - 3) change of *patient*, including the *patient* attributes;
  - 4) power supply source change, including the source utilized; and
  - 5) results of the last pre-use check.

*Check conformance by inspection and functional testing.*

The annexes of IEC 60601-1:2005+AMD1:2012+AMD2:2020 apply, except as follows:

## Annex C (informative)

### Guide to *marking* and labelling requirements for *ME equipment* and *ME systems*

Annex C of IEC 60601-1:2005+AMD1:2012+AMD2:2020 applies, except as follows:

*Addition:*

#### **201.C.101    *Marking on the outside of ME equipment, ME systems or their parts***

Additional requirements for *marking* on the outside of a *ventilator*, its parts and *accessories* are found in Table 201.C.101.

**Table 201.C.101 — *Marking on the outside of a ventilator, its parts or accessories***

Description of <i>marking</i>	Subclause
Arrow indicating the direction of the flow for <i>flow-direction-sensitive components</i> , if applicable	201.7.2.101 b) 2)
Arrow indicating the intended direction of gas flow for the <i>gas output port</i>	201.7.2.101 a) 1) i)
Arrow indicating the intended direction of gas flow for the <i>gas return port</i>	201.7.2.101 a) 1) ii)
For a <i>ventilator</i> intended for use in magnetic resonance (MR) environment, the appropriate <i>symbol</i>	201.7.2.101 b) 1)
For <i>accessories</i> supplied separately, indication of any limitations or adverse effects of the <i>accessory</i> on the <i>basic safety</i> or <i>essential performance</i> of the <i>ventilator</i> , if applicable	201.7.2.4.101 a) 2)
For <i>accessories</i> supplied separately, the requirements of 201.7.2.101	201.7.2.4.101
For oxygen gas inputs, the <i>rated</i> range of oxygen concentration	201.7.2.18 cc)
For packaging of breathing attachments, containing natural rubber latex, if applicable	201.7.2.17.101 b) 3)
For packaging of breathing attachments, description of the contents	201.7.2.17.101 b) 1)
For packaging of breathing attachments, identification reference to the batch, type or serial number	201.7.2.17.101 b) 2)
Gas name or chemical symbol for any gas-specific inputs and outlets, if applicable	201.7.2.18 aa)
Gas-specific colour-coding for any gas-specific inputs and outlets, if applicable	201.7.2.18 dd)
Mandatory action <i>safety sign</i> : follow instructions for use	201.7.2.3
<i>Rated</i> range of gas pressure	201.7.2.18 bb)
Warning not to obstruct the <i>gas intake port</i> , if applicable	201.7.2.101 b) 3)

#### **201.C.102    *Accompanying documents, general***

Additional requirements for general information to be included in the *accompanying documents* of a *ventilator* or its parts are found in Table 201.C.102.

**Table 201.C.102 — Accompanying documents, general**

Description of requirement	Subclause
For each <i>HFV breathing system</i> , its parts and <i>accessories</i> , a statement to the effect that ventilator breathing systems, their parts and accessories are validated for use with specific ventilators	201.102.2 b) 1)
For each <i>HFV breathing system</i> , its parts and <i>accessories</i> , a statement to the effect that incompatible parts can result in degraded performance	201.102.2 b) 2)
For each <i>HFV breathing system</i> , its parts and <i>accessories</i> , a statement to the effect that the responsible organization is responsible for ensuring the compatibility of the ventilator and all of the parts used to connect to the patient before use	201.102.2 b) 3)
For each <i>HFV breathing system</i> , its parts and <i>accessories</i> , the <i>model or type reference</i> of at least one compatible <i>ventilator</i>	201.102.2 a)
Maximum time-weighted average input flow for each gas, if applicable	201.4.11.101.2 3) i)
Maximum transient input flow for each gas, if applicable	201.4.11.101.2 3) ii)
Means by which the obstruction <i>alarm condition</i> is determined and a means to test it	201.12.4.108 d)
Units of measurement for volumes, flows and leakages	201.7.4.3
Warning that the <i>ventilator</i> is a high flow device, if applicable	201.4.11.101.2 3) iii)

**201.C.103 — Accompanying documents, instructions for use**

Additional requirements for information to be included in the *instructions for use* of a *ventilator* or its parts are found in Table 201.C.103.

**Table 201.C.103 — Instructions for use**

Description of requirement	Subclause
Accuracy of <i>mean airway pressure</i> , if control is provided	201.12.1.101 a)
A-weighted sound power level emitted by the <i>ventilator</i>	201.9.6.2.101 b) 2)
A-weighted sound pressure level emitted by the <i>ventilator</i>	201.9.6.2.101 a) 2)
Behaviour of the <i>ventilator</i> after a switchover to the <i>internal electrical power source</i>	201.11.8.101 j) 2) i)
Behaviour of the <i>ventilator</i> after a switchover to the <i>secondary supply mains</i> , if provided	201.11.8.101 j) 2) ii)
Behaviour of the <i>ventilator</i> while the <i>internal electrical power source</i> is recharging	201.11.8.101 j) 3)
Circumstances in which the <i>HFV</i> is intended for use with a <i>non-ventilator-dependent patient</i>	201.12.4.109 d) 1)
Conditions under which the <i>ventilator</i> maintains the accuracy of controlled and displayed variables	201.7.9.2.9.101 c)
Disclosure of any adverse effect of any recommended <i>accessory</i> on the <i>basic safety or essential performance</i> of the <i>ventilator</i> , if applicable	201.7.9.2.14.101 b) 2)
Disclosure of any restrictions on the placing of components within the <i>ventilator breathing system</i> , if applicable	201.7.9.2.14.101 b) 1)
Explanation of the meaning of the IP classification <i>marked</i> on the <i>ME equipment</i>	201.7.9.2.9.101 e)
For a <i>ventilator</i> , its parts or <i>accessories</i> intended for single-use, information on known characteristics and technical factors known to the <i>manufacturer</i> that could pose a <i>risk</i> if the <i>ventilator</i> , its parts or <i>accessories</i> would be reused	201.7.9.2.1.101 a)
For <i>accessories</i> supplied separately where <i>marking</i> the <i>accessory</i> is not practicable, the requirements of 201.7.2.4.101	201.7.2.4.101



Description of requirement	Subclause
For an <i>HFV</i> equipped with $\text{FiO}_2$ concentration control, the accuracy of the inspiratory oxygen concentration ( $\text{FiO}_2$ ) at the <i>patient-connection port</i> in relation to the set value	201.12.1.103 a)
For an <i>HFV</i> equipped with $\text{FiO}_2$ concentration control, the length of time required for the oxygen concentration in the <i>HFV volume</i> to change from a volume fraction of 21 % to 90 % of the maximum achievable oxygen concentration	201.12.1.104 a)
For an <i>HFV</i> equipped with <i>monitoring equipment</i> to indicate the <i>HFV volume</i>	201.12.4.105 b) 3)
For an <i>HFV</i> equipped with <i>monitoring equipment</i> to indicate the <i>pressure amplitude</i>	201.12.4.104 b) 3)
For an <i>HFV</i> not intended for use with a <i>patient-connection port</i> , the accuracy of the <i>mean airway pressure</i> limiting means	201.12.1.102 c)
For an <i>HFV</i> not intended for use with a <i>patient-connection port</i> , the accuracy of the <i>mean airway pressure</i>	201.12.4.103 c)
For an <i>HFV</i> with a <i>patient-connection port</i> , the accuracy of the <i>mean airway pressure</i>	201.12.4.102 c)
Instructions on where to connect $\text{O}_2$ <i>monitoring equipment</i> , unless such equipment is an integral part of the <i>ventilator</i>	201.12.4.101 c) 2)
Intended range of <i>patient weight</i>	201.7.9.2.1.101 b)
Maximum <i>alarm condition delay</i> of the disconnection <i>technical alarm condition</i>	201.12.4.109 e)
Maximum <i>limited pressure</i>	201.7.9.2.9.101 a) 1)
Means by which the secondary <i>supply mains</i> can be tested	201.11.8.101 j) i)
Method by which all of the <i>alarm signals</i> , including the <i>alarm signals</i> from any <i>distributed alarm systems</i> , can be functionally tested to determine if they are operating correctly	201.7.9.2.8.101 a) 3)
Method by which the assembled <i>HFV breathing system</i> can be functionally tested to determine if it is operating correctly	201.7.9.2.8.101 a) 1)
Method by which the switchover to and operation from the <i>internal electrical power source</i> , can be functionally tested to determine if they are operating correctly	201.7.9.2.8.101 a) 2)
Minimum <i>limited pressure</i> , for an <i>HFV</i> that can generate subatmospheric pressure in the <i>expiratory phase</i>	201.7.9.2.9.101 a) 2)
Operational time of the power sources when fully charged	201.11.8.101 j)
Processing <i>procedure</i> instructions for the <i>ventilator</i> and its <i>accessories</i>	201.11.6.6 cc) 2)
Rated range of <i>expiratory gas pathway</i> resistance over which the accuracies of set and monitored volumes and pressures are maintained	201.7.9.2.9.101 b) 2)
Rated range of <i>HFV breathing system</i> compliance over which the accuracies of set and monitored volumes and pressures are maintained	201.7.9.2.9.101 b) 3)
Rated range of <i>inspiratory gas pathway</i> resistance over which the accuracies of set and monitored volumes and pressures are maintained	201.7.9.2.9.101 b) 1)
Recommended <i>ventilation-mode</i> and settings for closed suctioning	201.9.101
Settings of <i>fail-safe ventilation</i>	201.7.9.2.9.101 j)
Statement to the effect that antistatic or electrically conductive hoses or tubing are not be used in the <i>ventilator breathing system</i>	201.7.9.2.14.101 a)
Statement to the effect that the <i>ventilator</i> is to be equipped with $\text{O}_2$ <i>monitoring equipment</i> for the measurement of inspiratory oxygen concentration before being put into service, if not so equipped	201.12.4.101 c) 1)
Warning statement to the effect that the <i>ventilator</i> shall not be used with inlet gases that are not specified for use (e.g. helium or mixtures with helium). Such use might cause the <i>ventilator</i> to not function correctly causing patient death or serious deterioration of health, if applicable	201.7.9.2.2.101 f)

Description of requirement	Subclause
Warning statement to the effect that, one should always have immediate access to an alternative means of ventilation, which is ready for use, in order to reduce the possibility of patient death or serious deterioration of health	201.7.9.2.2.101 b)
Warning statement to the effect that do not add any attachments or accessories to the ventilator that are not listed as intended for use in combination with the ventilator in the instructions for use of the ventilator or accessory as the ventilator might not function correctly leading to the risk of patient death or serious deterioration of health	201.7.9.2.2.101 c)
Warning statement to the effect tha, do not cover the ventilator or place in a position that affects proper operation”, including the applicable consequence	201.7.9.2.2.101 a)
Warning statement to the effect tha, it is the responsibility of the responsible organization to ensure that the oxygen source is compatible with the rated range of pressure, flowrate and oxygen concentration as marked on the ventilator and indicated in the instructions for use as this can affect the performance of the ventilator that can consequently result in patient death or serious deterioration of health, if applicable	201.7.9.2.2.101 h)
Warning statement to the effect that the ventilator accuracy can be affected by the gas added to the breathing system by use of a pneumatic nebuliser, if applicable	201.7.9.2.2.101 g)
Warning statement to the effect that the ventilator shall not be used in a hyperbaric chamber. Such use might cause the ventilator to not function correctly causing patient death or serious deterioration of health, if applicable	201.7.9.2.2.101 d)
Warning statement to the effect that, the ventilator shall not be used with nitric oxide. Such use might cause the ventilator to not function correctly causing patient death or serious deterioration of health, if applicable	201.7.9.2.2.101 e)
Warning statement to the effect that when using nebulization or humidification, breathing system filters and heat and moisture exchangers can require more frequent replacement to prevent increased resistance and blockage, if applicable	201.7.9.2.2.101 i)
When <i>fail-safe ventilation</i> is initiated	201.7.9.2.9.101 i)
Whether or not the <i>HFV</i> is intended for use with closed suctioning	201.7.9.2.9.101 f)
Whether or not the <i>HFV</i> is intended for use with nebulized medications and if so, any constraints	201.7.9.2.9.101 h)
Whether or not the <i>HFV</i> is intended for use with nitric oxide and helium	201.7.9.2.9.101 g)
Which portions of the <i>gas pathways</i> through the <i>ventilator</i> can become contaminated with body fluids or by contaminates carried by expired gases during both <i>normal condition</i> and <i>single fault condition</i>	201.7.9.2.12 aa)

### 201.C.104 *Accompanying documents, technical description*

Additional requirements for information to be included in the *technical description* of a *ventilator* or its parts are found in Table 201.C.104.

**Table 201.C.104 — Technical description**

Description of requirement	Subclause
Description of a <i>procedure</i> for checking the function of the <i>alarm system</i> for each of the <i>alarm conditions</i> specified in this document, if not performed automatically during start-up	201.7.9.3.101 a)
Disclosure of the essential technical characteristics of each recommended <i>breathing system filter</i>	201.7.9.3.1.101 b) 3)
Disclosure of the measurement uncertainty for each disclosed tolerance	201.5.101.3
Pneumatic diagram of the <i>ventilator</i> , including a diagram for <i>operator-detachable</i> parts of the <i>HFV breathing system</i> either supplied or recommended in the <i>instructions for use</i>	201.7.9.3.1.101 a) 3)
Summary description of the algorithm for how the <i>HFV volume</i> is calculated, including the averaging period	201.7.9.3.1.101 b) 2)
Summary description of the algorithm for how the <i>mean airway pressure</i> is calculated	201.7.9.3.1.101 a) 2)
Summary description of the algorithm for how the <i>pressure amplitude</i> is calculated, including the averaging period	201.7.9.3.1.101 b) 1)
Summary description of the filtering or smoothing techniques for all measured or computed variables that are displayed or used for control	201.7.9.3.1.101 a) 1)
Technical characteristics of each of the <i>patient airway</i> models used to determine <i>mean airway pressure</i> for an <i>HFV</i> without a <i>patient-connection port</i>	201.12.1.101 e)
Test method for determining the <i>HFV volume</i>	201.12.4.105 b) 4)
Which <i>alarm condition</i> function tests are automatically during start-up	201.7.9.3.101 b)





## Annex D (informative)

### *Symbols on marking*

Annex D of IEC 60601-1:2005+AMD1:2012+AMD2:2020 applies, except as follows:

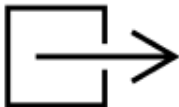
*Addition:*

**Table 201.D.2.101 — Additional symbols on marking**

No	Symbol	Reference	Title and description
1		IEC 60878:2015 <sup>[34]</sup> ISO 7000-0794	Input; entrance To identify an entrance, for example exhaust gas entry for measurement (for example of CO- value). For electrical (signal) input use <i>symbol</i> IEC 60417-5034.
2		IEC 60878:2015 <sup>[34]</sup> ISO 7000-0795	Output; exit To identify an exit, for example of a hydraulic pump. For electrical (signal) output use <i>symbol</i> IEC 60417-5035.
3		IEC 60878:2015 <sup>[34]</sup> <i>Symbol</i> 7.3.1-1 of IEC 62570:2014	MR Safe To identify an item which poses no unacceptable risks to the patient, medical staff or other persons within the MR environment. When color reproduction is not practical, the <i>symbol</i> may be printed in black and white. The use of the colored icon is strongly encouraged for the added visibility and information provided by the color.
4		IEC 60878:2015 <sup>[34]</sup> <i>Symbol</i> 7.3.1-2 of IEC 62570:2014	MR Safe Alternative graphical <i>symbol</i> representation. Same meaning as IEC 62570-7.3.1-1.
5		IEC 60878:2015 <sup>[34]</sup> <i>Symbol</i> 7.3.2 of IEC 62570:2014	MR Conditional To identify an item which poses no unacceptable risks within defined conditions to the patient, medical staff or other persons within the MR environment. When color reproduction is not practical, the <i>symbol</i> may be printed in black and white. The use of the colored icon is strongly encouraged for the added visibility and information provided by the color. The MR Conditional <i>symbol</i> may be supplemented by supplementary <i>marking</i> that describes the conditions for which the item has been demonstrated to be MR Conditional.

Additional Annexes:

## Annex AA (informative)

### Particular guidance and rationale

#### AA.1 General guidance

This Annex provides rationale for the important requirements of this document and is intended for those who are familiar with the subject of this document but who have not participated in its development. An understanding of the reasons for the main requirements is considered to be essential for its proper application. Furthermore, as clinical practice and technology change, it is believed that rationale for the present requirements will facilitate any revision of this document necessitated by those developments.

#### AA.2 Rationale for particular clauses and subclauses

The following are rationales for specific clauses and subclause in this document.

##### Subclause 201.1.1 – Scope

*Ventilators* conforming to ISO 80601-2-87 are not considered a *physiologic closed-loop control system* due to the fact that parameters monitored during delivery of respiratory gases that are also used to control the delivery of these gases are exclusively physical parameters of the delivered gases. Consequently, these parameters are considered equipment variables as specified in IEC 60601-1-10.

An *HFV* that uses the *HFV breathing system* pressure as a feedback to control *HFV breathing system* pressure is a closed-loop control system, but not a *physiologic closed-loop control system*. The *HFV breathing system* pressure is considered both a 'variable' influenced by the *patient* physical conditions and at the same time a 'feedback variable', but it is not a quantity or condition measured from the *patient's* physiology.

The physical condition of a *patient* is a disturbance on the closed-loop system but the *ventilator* does not adjust the *ventilation* therapy settings based on measurement of these *patient* parameters.

The requirements of this document do not require the *ventilator* to adjust *ventilation* delivery parameters based on the detection of the change in or of physiological conditions of the *patient*. All automatic adjustments of *ventilator* equipment parameters or generated *alarm conditions* are only based on the measurement of physical variables related to the delivery of breathing gas to the *patient-connection port* or at the distal outlet of the jet system. In this sense the *ventilator* ends at the *patient-connection port* or at the distal outlet of the jet system, (i.e., has no direct contact to the physiological parameters of the *patient*) and a change in the *patient's* physiological condition is a disturbance to the *ventilator's* control system that does not act to control the physiological change but continues to control the physical variable(s) to the original objectives.

*Ventilators* create *alarm conditions* when detecting faults in the delivery of breathing gases to the *patient-connection port* or at the distal outlet of the jet system but do not adjust *ventilation* setting using a *patient variable*.

The following are examples of medical devices that are considered *physiologic closed-loop control system*.

- Insulin infusion pump that adjusts the rate of insulin infusion to the *patient* based on the measurement of a blood glucose level or concentration. The physiological feedback variable is a blood glucose level monitored by the device.
- External pacemaker that adjusts the pace rate based on the measurement of the cardiac output value. The physiological feedback mechanism is the value detected by the cardiac output monitor.

Unlike a *ventilator*, these devices titrate delivery to the *patient* based on the measured physiological parameter. A *ventilator* will not titrate delivery of *ventilation* to the *patient-connection port* or at the distal outlet of the jet system but will either stop *ventilation* or generate an *alarm condition*.

**Definition 201.3.250 - Pressure amplitude**

For an *HFV* with a *patient-connection port*, which is intended to provide *high-frequency ventilation* via a tracheal tube, the *pressure amplitude* is defined as the peak-to-peak magnitude of the pressure swing at the *patient-connection port* during *high-frequency ventilation*. It is the driving parameter for the resulting *HFV volume*. See Figure AA.1.

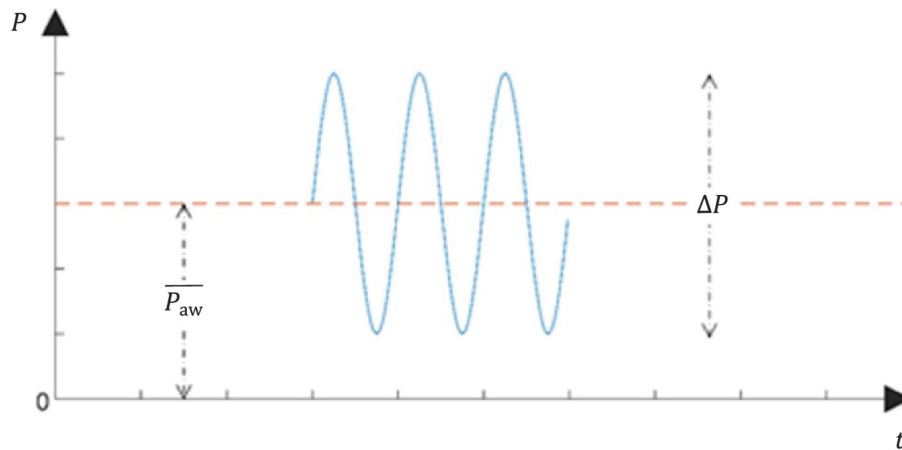

**Key**

- $\overline{P_{aw}}$  Mean airway pressure
- $t$  Time
- $P$  Pressure
- $\Delta P$  Pressure amplitude

**Figure AA.1 — Representative Pressure waveform in an HFV**

For an *HFV* without a *patient-connection port*, the only site at which a clinically useful *pressure amplitude* can be measured is external to the *airway device*, close to the distal outlet of the jet system. In this class of an *HFV*, the *HFV volume* is directly controlled, and the *pressure amplitude* is a consequence of the applied *HFV volume*, and the pneumatic impedance of the *patient airway* at that site. For this reason, an *HFV* of this type does not typically provide control or monitoring for *pressure amplitude*.

The *HFV-frequency* has an impact on *pressure amplitude*. In general, lower *HFV frequencies* permit higher *pressure amplitudes*. *Pressure amplitudes* and *HFV volumes* are influenced by the flow. Higher flows allow higher *pressure amplitudes* and in consequence higher *HFV volumes*.

At settings for high *pressure amplitudes* the *ventilator* measures considerable peak pressures at the *patient-connection port*.

During *HFV ventilation*, the period of oscillation is significantly shorter than the time constant of the *patient lung*. The additional resistance of the tracheal tube causes a considerable pressure drop. As a result, the oscillatory pressure in the *lung* is much smaller than the pressure amplitude.

For an *HFV* with a *patient-connection port*, regardless of the actual site of pressure measurement, the definition of *pressure amplitude* is referenced to the pressure at the *patient-connection port*.

Even small changes in resistance or compliance of the respiratory system (e.g., by secretion in the airways, through the use of a different *HFV breathing system* or tracheal tube) can change the *pressure amplitude* and in consequence the *HFV volume*.

Higher *HFV volumes* significantly increase CO<sub>2</sub> elimination.

#### **Subclause 201.4.3.101 – Additional requirements for essential performance**

An *HFV* can be used with *patients* with spontaneous breathing or other unpredictable responses. In such cases, and depending on the capabilities of the *HFV*, parameters such as the *mean airway pressure* and *HFV volume* can vary and deviate from the set value. *Essential performance* defined as “ventilation at the *patient-connection port* or at the distal outlet of the jet system within the *alarm limits* set by the *operator*” takes these deviations into consideration to allow for *ventilation* within the *alarm limits* set by the *operator*, or the generation of an *alarm condition*.

It is expected that the *healthcare professional operator* will set appropriate *alarm limits* which thereby define the *essential performance* for a particular *patient*.

The distributed *essential performance* criteria in Table 201.101 have been identified by the committees as the minimum clinical performance necessary to reduce the probability of exposing the *patient* to unacceptable *risk*. Conformance criteria for some of the clauses within IEC 60601-1, this document and the other applicable collateral standards include “maintain *essential performance*”. The committees have recognized the difficulty in confirming that all aspects of *essential performance* are maintained when completing longer duration testing.

Footnote a to Table 101 indicates methods of evaluating delivery of *ventilation* as acceptance criteria following specific tests required by this document. It is intended to provide criteria that can be used to easily confirm that *essential performance* has been maintained. Although the degradations detailed in 202.8.1.101 are associated with *immunity* testing, the same criteria are intended to be used when the conformance criterion from any other clause or subclause requires confirmation that *essential performance* is or has been maintained.

Those aspects of *essential performance* that cannot be reasonably linked to the conformance criteria within 202.8.1.101 need to be confirmed via other means. But one need only confirm that the specific requirements indicated in 202.8.1.101 that are likely to have an impact on specific clinical performance are maintained after testing.

**Subclause 201.4.6 – ME equipment or ME system parts that contact the patient**

Since much of the *HFV breathing system* is likely to be draped over or around the *patient*, it is likely to come into direct contact with the *patient* during *normal use*. Also of concern are electrical *hazards* should any circuitry be incorporated into the *HFV breathing system*. By ensuring that the *gas pathways* of the *HFV breathing system* and its parts or *accessories* are subject to the requirements for *applied parts*, these issues are addressed by the requirements already in the general standard.

**Subclause 201.4.11.101 – Additional requirements for pressurized gas input**

*HFVs* designed to be connected to a pressurised gas supply are required to continue to operate reliably throughout its *rated* range of supply pressures, but these pressures can only be maintained if the *ventilator* in *normal condition* does not attempt to draw more flow from the gas source than the gas source is designed to supply. It is also expected that a *ventilator* should be designed to prevent an unacceptable *risk* under possible *single fault conditions* of the pressurised gas supply.

Pressurised medical gas supplies, including *medical gas pipeline systems* and cylinder pressure regulators conforming to current relevant standards, supply medical gases to gas-specific terminal outlets at a pressure that is within an internationally agreed pressure range of 280 kPa to 600 kPa under *normal condition*. It is expected that *HFVs* should operate to their declared specification with any supply pressure within this range.

In the case of a pressure regulator failure, the gas supply pressure could rise to the pressure regulator's supply pressure that can be cylinder (tank) pressure. To safeguard against this or similar eventualities, gas-specific medical gas supply systems are required to be provided with a means to limit their output pressure to not more than 1 000 kPa. All gas-powered *ME equipment* should be designed so as not to present an unacceptable *risk* if its supply pressure rises up to this value but in the case of *HFVs* it is considered that, because all the *ventilators* in a critical care unit could be affected simultaneously, it is not acceptable that such *ventilators* should just generate an *alarm signal* and shut down under these overpressure conditions. For this reason, there is a specific requirement that *ventilators* should continue operation with acceptable performance so that *patients* can continue to be ventilated until such time as normal operation can be restored or alternative means of *ventilation* can be used.

*Ventilators* with maximum *rated* input pressures exceeding 600 kPa are required to fulfil these conditions at up to twice their maximum *rated* input pressure.

Under the *single fault condition* that the supply pressure of any one gas drops below 280 kPa, under steady-state conditions, it is understood that a *ventilator* cannot be expected to continue to operate on this gas. However, it is required that in this case the *ventilator* should detect the unacceptable low pressure, produce an *alarm signal* and also, in the case of two pressurised gas supplies, automatically switch to use the other gas source (oxygen or air) to drive the *ventilator*. This requirement is stated in subclause 201.13.101.



To ensure that the minimum pressure of 280 kPa can be maintained in practice, *medical gas pipeline systems* supplying compressed medical gases through gas-specific terminal outlets are designed so that they can maintain this pressure at the input of gas-powered devices whilst supplying steady-state flows up to 60 l/min at a single outlet connected directly to the pipeline; account is taken of the pressure drop in the pipeline supplying the outlet and the pressure drop, at 60 l/min, across the terminal unit and the hose assembly connecting the device to the pipeline.

The *medical gas pipeline system* is also required to be capable of supplying sufficient gas that this flow can be drawn from a predetermined number of adjacent terminal units simultaneously. The actual number will have been determined during the design and installation of the *medical gas pipeline system* by the application of a 'diversity factor'; a factor agreed between the supplier and *responsible organization* to be appropriate for each section of the installation according to the designated purpose of each area supplied. Recommended diversity factors are formulated to ensure that the *medical gas pipeline system* is capable of supplying an average flowrate of 60 l/min to the required proportion of terminal outlets. However, if the flowrate demand from many adjacent *ventilators* exceeds 60 l/min there is an increased possibility that the *ventilator* input pressure could fall below 280 kPa, mainly because of the increased pressure drop across the terminal unit and input hose (also because of the flow-drop characteristic in the case of pressure regulators supplying a single terminal outlet).

In addition to steady-state flows of 60 l/min, the switching of the internal pneumatic system and the operation of a *patient* demand system can result in a *ventilator* requiring transient input flows far in excess of 60 l/min. Because of the compressibility of gas at pipeline pressures and the diameter of piping that is employed in order to minimise pressure drop, such transient demands can generally be accommodated from the gas stored locally within the pipe work of the *medical gas pipeline system*. There can be temporary pressure drops of the input pressure at the inlet of the *ventilator* to below 280 kPa due to transient flows in excess of 200 l/min over 3 s, but most of these drops will be within the supply hose assemblies specified by the *manufacturer*. *Manufacturers* need to evaluate their own designs to establish whether any consequent transient pressure drop affects the performance of their *ventilator* when used with recommended supply hose configurations and when connected to alternative gas-specific terminal outlets such as those fitted to cylinder pressure regulators conforming to ISO 10524-1 <sup>[11]</sup>.

*Ventilators* that can draw greater average or transient flows during *intended use* are permitted, but their *accompanying documents* are required to disclose those flows and warn of the need for a different diversity factor.

The average flowrate of 60 l/min is greater than the test flowrate used during the commissioning of a *medical gas pipeline system*. In itself, this should be of no concern because the specific conditions specified for the test do not allow a direct comparison between the two values. The committee responsible for *medical gas pipeline systems* standards, ISO/TC 121/SC 6, in consultation with ISO/TC 121/SC 1 and ISO/TC 121/SC 3, agreed to the 60 l/min average flowrate value, and also the 200 l/min for up to 3 s transient flows, during the preparation of the first edition of the current series of standards for *medical gas pipeline systems* and were aware of the need to satisfy that specification when finalizing the *medical gas pipeline system* test requirements.

*Manufacturers* should be aware that other medical gas system supply standards permit the fitting of gas-specific terminal outlets to spur systems such as pendant supply units. Such subsystems restrict the flow that can be drawn from their terminal outlets.

### Subclause 201.5.101.2 – Gas flowrate and leakage specifications

Quantities of gas are frequently expressed as the volume that the gas occupies at standardized conditions. Generally, one atmosphere (101,3 kPa) is used as standard pressure. However, several standard temperatures are used. Whereas 0 °C is used as standard temperature in physics, either 20 °C or 21,2 °C (70 °F) is often used in engineering. In *ventilation*, the gas in the *lungs* has a temperature identical to body temperature (~ 37 °C) irrespective of the temperature of the gas delivered by a *ventilator*. The volume of a given amount of gas increases by about 13,5 % from 0 °C to 37 °C or by 5,8 % from 20 °C to 37 °C.

Gas delivery systems supplying pressurised gas to medical equipment, including *ventilators*, follow engineering conventions and specify gas quantities and flowrates at *STPD* conditions. This practice is followed in this document for all requirements concerning gas input.

However, *ventilators* conforming with this document are likely to be inflating the *patient's lungs* relative to a local atmospheric pressure between 70 kPa and 110 kPa. In addition, the gas in the *lungs* is always saturated with water vapour regardless of the humidity of the gas delivered from a *ventilator*. With a standard temperature of 0 °C, 1 l of gas referenced to *STPD* (*standard temperature pressure dry*) can expand the *lungs* to 1,8 l at a pressure of 70 kPa. In order to have the values comparable among different *ventilators*, it is essential that the information for all *ventilators* is referenced to the same standard conditions. Because it is the volume of gas and not the number of molecules that expands the *lungs*, *BTPS* is the appropriate set of reference conditions to use.

In *ventilators* a variety of flow transducers are used. Whereas a heated-wire anemometer measures the rate of mass flow of the gas independent of pressure, a pneumotachograph measures the flow of gas at the actual pressure. Therefore, the necessary corrections depend on the type of flow transducer. When a pressure correction is required, this can be adequately estimated.

The necessary corrections also depend on the location of the flow transducer. The humidity of the gas can be zero when the transducer measures the inspired flow inside the *ventilator*. When, however, the flow transducer is located at the Y-piece, the relative humidity can be up to 100 %.

### Subclause 201.5.101.3 – Ventilator testing errors

When testing *ventilator* performance several of the test parameters cannot be measured without a significant degree of measurement uncertainty due to limitations of the accuracy that can be achieved, particularly when measuring volumes by the integration of rapidly changing flows.

Because of the relative significance of these uncertainties, it is important that *manufacturers* allow for them when declaring parameter accuracy.

Similarly, it is important for a third-party tester to recognise the significance of the uncertainty in their own measurements when testing to this document.

In practice, this means that, for example, if a *manufacturer* determines that a parameter has an intended tolerance of  $\pm 10$  %, but the measurement uncertainty is  $\pm 3$  % then the test acceptance criteria is  $\pm 7$  %. If a third party is testing to this document, they also need to include measurement uncertainty in their testing. If they subsequently obtain an error of the measured value for that parameter of  $\pm 15$  %, with a measurement uncertainty of  $\pm 5$  %, then the third-party tester has to accept the *manufacturer's* claim.

Furthermore, the *manufacturer* is required to disclose the measurement uncertainty for each declared value in order to provide both information to the *responsible organization* and guidance for a third-party tester as to the needed measurement accuracy when testing to this document.

**Subclause 201.7.2.3 – Consult *accompanying documents***

The committee agreed that following the *instructions for use* is a mandatory action for the safe operation of a *ventilator*.

**Subclause 201.7.4.3 – Units of measurement**

Additional information is found in rationale for 201.5.101.2.

**Subclause 201.7.9.2.2.101 – Additional requirements for warnings and safety notices****a)**

A cover (e.g., a curtain or an unfavourable position of the *ventilator*) could cause the air inlets or openings of the *enclosure* to be partly or fully blocked. Air inlets are inlets for ambient air for blower-driven *ventilators* or *emergency intake ports*.

Openings in the *ventilator* housing are required for circulation of air for cooling and removal of leaked medical gases of the *ventilator*.

**b)**

In case of a severe *ventilator* failure, the *ventilator* stops ventilating the *patient*. There is no backup mechanism for an alternative means of *ventilation* integrated in the *ventilator*; a *ventilator* is not required to be functional under *single fault condition*. To keep the time for a possible interruption of the *ventilation* of the *patient* as short as possible, an alternative means of *ventilation* has to always be available close to the *ventilator*.

**c)**

Additional attachments or other components or subassemblies increase the resistance and compliance of the *HFV breathing system*. The additional flow of a pneumatic nebuliser or the sampling flow of a diverting gas monitor could have a negative impact on the accuracy of the measurements of flowrates and oxygen concentrations.

**d)**

Components of *HFVs* are typically not designed for the high ambient pressures in a hyperbaric chamber (e.g., 2 000 hPa). Pressure sensors (e.g., for *airway pressure* and ambient pressure) are especially inaccurate, with the consequence of a severe failure of the *ventilator*. The high ambient pressure also can cause an incorrect measurement of the flowrate and oxygen concentration.

The much higher partial pressure of oxygen in a hyperbaric chamber would increase the *risk* of fire in the *ventilator*. A *ventilator* intended for use in a hyperbaric chamber requires special design considerations beyond the requirements of this document.

**e)**

Nitric oxide can cause significant material compatibility issues with the components (e.g., pressure sensors) of some *HFV breathing systems*. Many *high-frequency ventilators* specific for use with neonates are designed to allow for the use of nitric oxide. The *accompanying documents* of the *high-frequency ventilator* should specify whether it is compatible with nitric oxide.

*f)*

Helium and gas mixtures with helium have characteristics that are significantly different from those of air or air-oxygen mixtures. This decreases the accuracy of the flowrate measurement and impairs the *ventilation* function.

Because of the changed oxygen concentration caused by helium or mixtures of helium the delivered oxygen concentration for the *patient* would be incorrect. *False positive alarm conditions* for high oxygen level and low oxygen concentrations can result.

Because of the very low density of helium, the gas leakage in the *HFV breathing system* is also increased. The low density also has an impact on the measurement of the resistance in the *HFV breathing system*.

*g)*

The additional gas flow in gas volume reduces the accuracy of the flowrate measurement with a subsequent impairment of the *ventilation* function.

*h)*

*Ventilators* need for their proper function a specific range of pressure, flowrate and gas concentration at the *high-pressure inlets*. Deviations of the inlet gas concentration for oxygen can influence the calibration of the oxygen sensor. Significant inaccuracies of the measurement of inspiratory oxygen concentration can occur. When this happens, the delivered oxygen concentration could be significantly outside the accuracy specified by the *manufacturer*.

In case the pressure or the deliverable flow of the central gas supply is too low, the *ventilator* would switch over to the remaining gas, e.g. from oxygen to air, with impact on the delivered oxygen concentration.

*i)*

The functionality of *breathing system filters* is affected by a number of aspects of structure, properties and local environment.

At the most basic, a *BSF* is designed to be a filter that removes particles suspended in gas, (i.e., a "dry aerosol"). The particles primarily targeted in the *HFV breathing system* are bacteria or virus particles (although other particles would be subject to retention). The filtering material ("medium") is composed of a matrix of solid material with open passageways to allow gas flow. The passageways in such gas filters are relatively large compared to the bacteria and virus particles that are to be removed. The spatial arrangement of the solid part of the filter medium versus the open spaces in the medium brings the particles in proximity to the surfaces of the medium, where physical forces (electrostatic attraction and Van der Waals forces) attract and bind the particles within the matrix, removing them from the gas flow.

In the practical situation of anaesthesia or respiratory care therapy, environmental factors related to the *patient*, or the therapy can alter the performance of the *BSF* from that which would occur in the simple flow of air with suspended microorganisms through the *BSF*.

One major factor is the presence, phase and amount of moisture present in the airflow.

When there is low humidity in the air (gaseous phase moisture) the gaseous water molecules will generally pass through the filter medium without effect. If there is a sufficiently high relative humidity, some *BSFs* can adsorb or absorb part of this humidity.

If the moisture exists as a liquid aerosol, the water droplets can also be retained by the filter.

The properties of a filter medium that govern the degree to which this interaction with water takes place is its relative affinity for water. A medium which readily attracts water is termed “hydrophilic” and a medium which repels water is termed “hydrophobic”. These properties are, in fact, not discrete, but exist on a continuous scale. Nevertheless, in common parlance filters are grouped into being (relatively) hydrophilic or hydrophobic.

Another example of liquid phase water can be termed “bulk water”. An example of this is the collected condensate that occurs in the expiratory limb of the *HFV breathing system*. Depending on the management of the circuit, and the positioning of the *BSF*, this bulk water can actually completely cover and occlude the filter. If a sufficient pressure is applied, the liquid water can be forced through the pores of the filter medium. This requires relatively low pressure for a hydrophilic filter and relatively high pressure for a hydrophobic filter.

The practical consequences of the latter scenario is that if liquid is forced through a hydrophilic *BSF*, gas flow blockage can be relieved, but any microorganisms removed by the filter can be carried past the filter with the liquid stream. In the case of a hydrophobic filter, the pressure in the *HFV breathing system* is usually not sufficient to force liquid through the medium, so the microbial retention is not compromised. Airflow occlusion persists, however, until steps are taken to remove the bulk water.

In addition, there can be a temporal aspect to the properties of relative hydrophilicity or hydrophobicity; whereby prolonged exposure to water alters these properties during the *expected service life* of the *BSF*. A *BSF* is typically labelled with an *expected service life*, in hours or days, that reflects its ability to perform to its labelled specifications in the clinical environment.

It should be obvious that the potential influence of water on performance differs in anaesthesia and respiratory care applications, although many, if not most, *BSFs* are indicated for use in both applications.

Additional effects on *BSF* functionality can be caused by the introduction of substances other than water or gas into the device. Such substances can originate from the *patient* (e.g., sputum, exudates, blood, vomitus) or substances introduced by the *operator* into the *HFV breathing system* (e.g., gross amounts of medications intended to be nebulised for administration through the *HFV breathing system*).

The effect of such substances can be an increase in flow resistance of varying degree up to complete occlusion at *ventilator* or physiologic pressures. In the case of nebulised medications, the type of nebuliser, and its operating parameters are variables that affect the likelihood or magnitude of significantly increased *BSF* flow resistance during a prescribed medication regimen. It should be mentioned that accidental introduction of gross amounts of medication from the nebuliser reservoir during *operator* or *patient* manipulation of the *HFV breathing system* has been implicated as a source of acute *BSF* blockage.

The cause of increased flow resistance in a *BSF* can be gross blockage of the medium passages, or the effects of surfactant properties of the substances introduced into the *BSF* upon the hydrophobicity of the filter medium. It should be noted that medications indicated for nebulisation can contain surfactant materials that are not identified in the medications’ labelling with respect to their presence or their quantity, and these can change without notice for a given medication. The effect of these substances upon flow resistance differs among individual models and brands of *BSFs*.

The *operator* needs to be aware that the effects of such substances can be manifested as increases in the amount of positive *airway pressure* required for a *ventilator*-provided breath, or as an

increase in expiratory flow resistance, resulting in a step-wise increase in intrapulmonary pressure that, if not detected, can lead to pneumothorax.

Awareness of the possibility, albeit infrequent or rare, of such significant increases in *BSF* flow resistance, and inclusion in a trouble-shooting scheme for this and other causes of impaired *ventilation* can reduce or eliminate adverse events occurring secondary to *BSF* flow occlusion.

Direct *patient* monitoring, and usage of the appropriate settings for, and prompt attention to, *ventilator alarm conditions* are essential to provide maximum *patient* safety.

Once a *BSF* is recognized to be a source of impaired *ventilation*, simply removing the occluded *BSF* and replacing it with another *BSF* returns *ventilation* to a normal state.

#### **Subclause 201.7.9.2.8.101 – Additional requirements for start-up procedure**

In some designs, adequate checking of the *alarm system* can be performed with a combination of *operator* action and the power-on self-test routines that verify the integrity of the software and the computer controlling the *ventilator*, as well the measuring sensors and the *alarm signal* generation.

#### **Subclause 201.7.9.2.9.101 – Additional requirements for operating instructions**

##### **b)**

Some *ventilators* are designed so that they can operate with higher-than-normal tubing circuit compliance and resistance. This can be required to provide the greater length needed during MRI *procedures*, for example. Thus knowledge of these *HFV breathing system* characteristics is important for the *healthcare professional operator* to be aware of the *ventilator* capability. Also, knowledge of the maximum *HFV breathing system* resistance (at *nominal* and maximum flowrates) is important because an occlusion *false positive alarm condition* can be caused by the use of high-resistance components in the *HFV breathing system*. These characteristics of the *HFV breathing system* need to be inclusive of any inhalation and exhalation particle/*BSF*, *humidifier*, nebuliser, water collection vessels and connectors needed for operation.

#### **Subclause 201.7.9.2.14.101 – Additional requirements for accessories, supplementary equipment, used material**

The use of antistatic or electrically conductive materials in the *HFV breathing system* is not considered as contributing to any higher degree of safety. On the contrary, the use of such material increases the *risk* of electrical shock to the *patient*.

#### **Subclause 201.7.9.3.1.101 – Additional general requirements**

##### **a) 1)**

The *manufacturer* is expected to express the description of the *ventilator* in general terms so that the reader can understand the important behaviour of the *ventilator* (e.g., mean values and their time specifications, number of breaths and delays, etc.).

#### **Subclause 201.9.6.2.1.101 – Additional requirements for audible acoustic energy**

#### **Table 201.101 – Test conditions for acoustic tests**

After due consideration, the committee decided that where this document specifies adjoining ranges for variables as the basis for testing and the declaration of performance, the end value of both ranges should be applicable to both ranges. This means that a *manufacturer* is free to use a round number end value (e.g., 300 ml) in specifications and is not forced to truncate artificially

the declared range in order to avoid having to satisfy also the test requirements of the adjacent range. This permits, for example, one *ventilator* to have a declared patient weight range of less than or equal to 8 kg and another 8 kg to 45 kg, with each *ventilator* only being required to be tested for the conditions specified for  $\leq 8$  kg or  $\geq 8$  kg respectively.

#### **Subclause 201.9.101 – Additional requirements for suction procedures**

It is now common practice in critical care areas to use a closed *suction catheter* during *artificial ventilation* of a *patient*. Use of a closed *suction catheter* allows uninterrupted *artificial ventilation* without disconnection of the *HFV breathing system* from the tracheal tube, tracheostomy tube or other *airway device*. This is in contrast to the use of a traditional open *suction catheter* which requires the opening or disconnection of the *HFV breathing system* before application of subatmospheric pressure to the respiratory tract.

For those *high-frequency ventilators* that have a *patient-connection port* and are used with a conventional *airway device*, a closed *suction catheter* has the same advantages as for conventional *ventilation*, and the same requirements are appropriate as are specified in ISO 80601-2-12 [23].

However, those *high-frequency ventilators* that do not have a *patient-connection port* typically have a distal outlet within an application device that provides a unidirectional but interrupted gas flow. The application device may be a catheter, for example in application to laryngotracheal surgery, or it can be another device such as a gas channel within a rigid bronchoscope. Exhalation gases pass around the outside of the application device and out of the *patient's* patent upper airway. In this scenario, there is little if any evidence that secretions can cause a blockage of the application device – the unidirectional gas flow acts to prevent secretions entering the jet tip. Any suctioning for secretions is effected using an open suction catheter external to the application device, in consequence the risks that this subclause addresses do not apply.

A closed *suction catheter* is provided with an adaptor that permits its connection at the *patient-connection port*. When used as intended, an in-line or closed *suction catheter* and related suction equipment become an *accessory* to the *ventilator* and an extension of the *HFV breathing system*. When an *HFV breathing system* is equipped with a *suction catheter* adaptor, the *patient* end of the closed *suction catheter* adaptor becomes the 'new' *patient-connection port*.

While use of closed *suction catheters* is regarded as expected *normal use* by a *healthcare professional operator*, the related subatmospheric pressures within the breathing system have been known to damage some *ventilators* [47][64].

The purpose of this requirement and test method is to replicate these worst-case in-use conditions caused by a closed *suction catheter* and to demonstrate that a *ventilator* resumes intended function after (but not during) the use of a *suction catheter*.

#### **Subclause 201.11.1.2.2 – Applied parts not intended to supply heat to a patient**

The human airway has a very significant ability to absorb or deliver heat and moisture. Reference the common practice of sitting in a sauna without *harm* to the respiratory tract [55]. Fully saturated gas at 45 °C can be inspired for up to 1 h without damaging the mucosa of the respiratory tract [62]. A more recent study reported tolerance of inspired gas temperatures of 46,9 °C to 49,3 °C, 100 % RH (265,6 kJ/kg) for 45 min [52].

Taking into account the enthalpy of inspired gas that has been shown to be tolerated without causing thermal injury to the human airways and the very short exposure times of thermal overshoot from a *ventilator* in clinical practice, the delivered gas energy limit of 197 kJ/m<sup>3</sup> of dry gas when averaged over 120 s can be used.

When considering gas mixtures other than oxygen/air, the following should be observed. Given that most of the energy is contained in the water vapour, the equivalent of air at 43 °C, 100 % RH is the maximum enthalpy that should be allowed. This has a specific volume of 0,9786 m<sup>3</sup>/kg of dry air and an enthalpy content of 197 kJ/m<sup>3</sup> of dry air. Assuming the volume breathed by the *patient* is the same whatever gas mixture is used, then the safe enthalpy limit is 197 kJ/m<sup>3</sup> of dry gas. This enthalpy per unit volume gives a more relevant measure of the energy delivered to the *patient*.

Sustained delivered gas temperatures above 41 °C can be hazardous depending on the combination of gas temperature, level of water saturation and *patient* exposure time. This was confirmed by studies conducted by the US Navy Medical Research and Development Command [62], where they concluded that fully saturated gas at 45 °C can be inspired for up to 1 h without damaging the mucosa of the respiratory tract.

Gas at body temperature and fully saturated (37 °C and 100 % RH) does not transfer thermal energy to or from the *patient* with a normal body temperature of 37 °C. Dry gas at body temperature (37 °C and 0 % RH) draws heat away through evaporation. Gas at 41 °C and fully saturated has the capacity to deliver less than 181,3 kJ/m<sup>3</sup> of dry gas delivered to the *patient-connection port* or at the distal outlet of the jet system.

The enthalpy content of 197 kJ/m<sup>3</sup> to limit the energy transfer of humidified breathing air to the respiratory tract of a *patient* with bypassed upper airways has been in use for a long time and no negative feedback with regard to this limitation was known at the time of the consideration of this document. The committees asked for clinical advice as to whether in addition to the enthalpy limitation, the temperature needed also to be limited. A German group of clinicians after considering the issue and the literature available came to the following conclusion:

The literature shows: [52][59][62]

- thermal inhalational traumas with temperatures above 100 °C but with unknown humidity content;
- the very low RH of about 5 % only at 100 °C with an enthalpy content of 197 kJ/m<sup>3</sup>;
- the good experience with the limit of enthalpy content of 197 kJ/m<sup>3</sup> of dry air in humidified breathing gases;
- the physical facts that a blower/turbine type *ventilator* increases the temperature of the gas taken from the environment in the range of 15 °C to 25 °C;
- *ventilators* are used in environments up to 45 °C;
- an additional temperature limitation is intended to limit the temperature under worst-case condition; and
- a sufficient safety margin to protect the *patient* from thermal injuries of the airway.

The clinician group recommended to keep the thermal energy limitation of 197 kJ/m<sup>3</sup> and add a maximum temperature limitation of 70 °C, whichever is lower. The committees agreed and confirmed this proposal.

#### **Subclause 201.11.6.5.101 – Additional requirements for ingress of water or particulate matter into *ME equipment* or *ME system***

*HFVs* are life-sustaining. Fluids commonly found in the critical care environment include saline, blood and other body fluids.



The committee agreed that the IP22 designation provided the most appropriate requirements to ensure that the *ventilator*, its *accessories* and parts maintain *basic safety* and *essential performance* during *normal use*.

#### **Subclause 201.11.6.6 – Cleaning and disinfection of ME equipment or ME system**

The *essential principles* of ISO 16142-1 require that medical devices are not to be operated or used if their condition could compromise the health and safety of the *patient* on whom they are being used or the employees or third parties interacting with them.

This means that *ventilators*, their *accessories* and parts cannot be used if there is a unacceptable *risk* of the *patient*, *operator* or other person being infected as a result of contact with the *ventilator*, *accessory* or part.

Therefore prior to reuse, *ventilators*, their *accessories* and parts require an appropriate level of *disinfection*, depending on their use, but rarely need to be *sterile*.

Recommendations for hygienic *processing* of *ventilators*, their *accessories* and parts are based on the general hygiene requirements for the *processing* of medical devices and need to take into consideration the special requirements and needs of *patient* care in the clinical environment. The requirements for hygienic *processing* in this document are intended to:

- make the *responsible organization* for *processing* the *ventilator* aware of how to implement these tasks in a responsible manner through appropriate delegation; and
- help all parties involved in the *processing* of *ventilators*, their *accessories* and parts to comply with the *manufacturer's* instructions.

The *cleaning* and *disinfection procedures* of the *manufacturer* are also intended to provide practical support to all those involved in *patient* care in the clinical environment with regard to implementing the hygiene measures required for the *patient's* safety.

The *manufacturer* is encouraged to concentrate on four essential aspects of *cleaning* and *disinfection*:

- a) the external *enclosure* of the *ventilator*;
- b) the *ventilator's* removable breathing circuit, including *accessories* and parts (e.g., *humidifier*, removable flow sensor, connectors, water traps, *breathing system filters*);
- c) the internal *gas pathways* that can become contaminated with body fluids or by contaminants carried by expired gases during *normal condition* or *single fault condition*, which generally reside within the *ventilator's enclosure* and are normally replaced or processed between *patients*; and
- d) the internal *gas pathways* that cannot become contaminated with body fluids or by contaminants carried by expired gases during *normal condition* or *single fault condition*, which generally reside within the *ventilator's enclosure* and are not normally removed or processed between *patients*.

Regarding the *cleaning* and *disinfection* or *cleaning* and *sterilization* of a), b) and c), above, *manufacturers* are required to provide detailed, *validated procedures* for ensuring safe and effective *processing* to protect the next *patient*, caregivers, technicians and third parties from pathogenic contamination. *Manufacturers* are required to document these *procedures* in the *accompanying documents* of the *ventilator*. Since the *gas pathways* described in d) above are not

contaminated by a *patient*, *manufacturers* are not required to provide *validated procedures* for *processing* them. Item c) and to some extent item d), the *disinfection* of the *ventilator's* internal *gas pathways*, have received renewed attention due the recent outbreaks of contagious diseases like Legionnaires disease, SARS (severe acute respiratory syndrome) and influenza that affect the respiratory system.

Most modern *ventilators* are designed to permit removal, either for replacement or *processing*, of those portions of the internal *gas pathways* that can become contaminated with body fluids or by contaminants carried by expired gases during *normal condition* or *single fault condition*. *Responsible organizations* need to follow their infection control *procedures* when transferring a *ventilator* from one *patient* to another.

In the event that the *responsible organization* suspects that the internal *gas pathways* of a given *ventilator* might have become contaminated with pathogenic material from the previous *patient*, the committee suggests a three-step *process* in the following order to assess next actions:

- ensure that the breathing circuit and all *accessories* have been removed and dealt with according to applicable *procedures*;
- thoroughly disinfect all outer surfaces of the *ventilator enclosure*, including the outer surfaces of the *gas output port* and *gas return port*; and
- only after executing the previous two steps, swab the inner surfaces of the *gas output port* and *gas return port* and culture the swabs to determine if pathogenic material is present.

If contagious pathogens are detected, the *responsible organization* should follow the *manufacturer's processing procedures* found in the *accompanying documents* to protect the next *patient*, caregivers, technicians and third parties from those detected pathogens. The *responsible organization* should be aware that sensitive and expensive sensors are likely located in the expiratory *gas pathways*. Follow the *accompanying documents* of the affected *ventilators* to ensure that delicate and possibly fragile sensors are not damaged during the *processing procedure*.

Any *ventilator* that has already been used on another *patient* could be contaminated with contagious pathogenic microorganisms until proven otherwise. Appropriate handling and *processing procedures* are essential to protect the next person handling the device or the next *patient* on whom the device is used. Hence the *gas pathways* of *ventilators*, their reusable *accessories* and parts that can become contaminated with body fluids or by contaminants carried by expired gases during *normal condition* or *single fault condition* and have been used should, when required for appropriate infection control, undergo a *processing procedure* following the *manufacturer's* instructions, prior to reuse by another *patient*.

The following basic considerations need to be addressed by the *manufacturer* when specifying the *processing* instructions of a *ventilator*, its *accessories* or parts:

- protecting the *patient*, the *operator* and the *responsible organization* (including personnel involved in performing the *processing procedure*);
- the limits of the *procedures* used for *processing* (such as the number of *processing* cycles); and
- the necessity to guarantee that standardised *procedures* have consistently high and verifiable quality, based on an established quality management system.

The recommended *processing procedure* should be determined by:

- the potential degree and type of contamination of the *ventilator, accessories* or parts; and
- the *risk* of infecting another *patient* resulting from their reuse and the type of application of the *ventilator*.

Special consideration of the possible *risk* associated with the contamination of gas-conducting components due to the *patient's* rebreathing under *single fault condition* is required.

On the basis of the above, a *verified* and *validated* documented *processing procedure* needs to be specified in such detail so that the outcome is reproducible. An acceptable *residual risk* from the *hazard* of infection for the next *patient* can be assumed if the:

- documented *processing procedure's* effectiveness has been *verified* through appropriate scientific methods by the *manufacturer*; and
- reliability of the documented *processing procedures* has been *verified* in practice through appropriate quality assurance measures by the *responsible organization* carrying out the *processing procedures*.

When selecting and evaluating the *processing procedures*, the *manufacturer* should consider:

- the amount and type of pathogenic microorganisms expected to contaminate the *ventilator, accessories* or parts;
- the *risk* for the pathogenic microorganisms to be transmitted to the *patient, operator* or other persons; and
- the microorganism's resistance to the recommended *processing procedures*.

The *risks* posed by a processed *ventilator, accessories* or parts are determined by the following factors:

- e) undesired effects, which can result from:
  - the previous use,
  - the previous *processing procedures*, and
  - transportation and storage;
- f) the *risks* from subsequent uses, such as the following:
  - residues from the previous use (such as secretions, other body fluids and drugs),
  - residues from the previous *processing procedures* such as *cleaning* agents, disinfectants and other substances, including their reaction products,
  - changes of physical, chemical or functional properties of the device, and
  - changes in the condition of the material (such as accelerated wear and tear, embrittlement and changed surface conditions, connectors and adhesive joints);
- g) the *risk* of transmission of any pathogenic microorganisms.

When considering the suitability of the *processing procedure* and the feasibility of the *processing procedure* for the *ventilator, accessories* or parts, the *manufacturer* should consider the following points:

- the *risks* involved in the *processing procedure*;
- the cost effectiveness of the *processing procedure*;
- the practicability of the *processing procedure*;
- the availability of the *cleaning* equipment and the *cleaning* agents specified in the *processing procedure*;
- the efficiency of the *processing procedure*;
- the reproducibility of the *processing procedure*;
- quality management requirements of the *processing procedure*; and
- the environmental impact of the *processing procedure* and the disposal of the *ventilator, accessories* or parts.

The *manufacturer* should verify all *cleaning* agents and *processing procedures* used with regard to their suitability and repeatability with the *ventilator, accessories* or parts, depending on the type of use.

The *responsible organization* should verify that *cleaning* and *disinfection* of the *ventilator, accessories* or parts are always carried out in accordance with the *procedures* specified in the *accompanying document*.

The *manufacturer* should specify *validated* automated *cleaning* and *disinfection procedures*. If they are not followed, the effectiveness of the *cleaning* and *disinfection* cannot be guaranteed. Such parameters could include the volume of water used, water pressure, temperature, pH, dosage of *cleaning* agents and disinfectants, and residence time.

To ensure the reproducibility of automated *processing procedures*, tests should be carried out on a regular basis.

The *manufacturer* should ensure that the specified *disinfection procedures* are *verified* to be bactericidal, fungicidal and virucidal so that the cleaned and disinfected *ventilator, accessories* or parts do not pose an unacceptable *risk* of infection by reproductive pathogenic microorganisms when any of these elements, collectively or individually, comes in contact, either directly or indirectly, with the next *patient, operator* or other person.

Effective *disinfection* requires that the instructions for the disinfectant, especially with regard to concentration and residence time, are followed.

Following any *processing procedure*, a safety and functional testing of the *ventilator* (as specified by the *manufacturer's* instructions) needs to be carried out. If necessary, safety-relevant functional testing can be carried out directly before use of the *ventilator*.

The extent and type of the tests depends on the *ventilator, accessory* or part and these need to be defined in the *accompanying document*.

### **Subclause 201.11.8.101 – Additional requirements for interruption of the power supply/supply mains to ME equipment**

ISO 80601-2-12 <sup>[23]</sup> requires for critical care *ventilators* that the *internal electrical power source* can supply the *ventilator* for at least 30 min when the *supply mains* falls outside the values necessary to maintain *patient ventilation*. For an *HFV* this period of time has been shortened to at least 15 min.

The highest *inflation rate* for a critical care *ventilator* is typically 150 min<sup>-1</sup>. For an *HFV*, *HFV frequencies* up to 3 000 min<sup>-1</sup> are possible. Under these conditions, the power consumption of an *HFV* can be significantly higher (e.g., caused by higher switching rates of the pneumatic valves). The committees consider 15 min as an adequate compromise. It is sufficient to bridge a power failure of *supply mains* with an *internal electrical power source* for this shorter period while not making the size and weight of the *internal electrical power source* too large to be awkward.

The operating time of a battery depends significantly on the number of charging and discharging cycles. Therefore, the committees decided that the *manufacturer* has to disclose the operating time in the *instructions for use* with both fresh and with aged batteries.

For aging a battery, the number of charging and discharging cycles was defined by the committees with 10 cycles for a *stationary ventilator* and additional 40 cycles for a *transit-operable ventilator*, which means in total 50 cycles.

The assumption for the 10 cycles for a *stationary ventilator* was that every month there would typically be a single power breakdown in the hospital.

The assumption for the 50 cycles for a *transit-operable ventilator* was that 40 times per year the *ventilator* would be used for *patient* transport within the hospital and that every month there would typically be a single power breakdown in the hospital.

### **Subclause 201.12.1 – Accuracy of controls and instruments**

The committee considered that the accuracy of set and displayed values is a key component of the *essential performance* of a *ventilator* (i.e., the delivery of *ventilation* at the *patient-connection port* or at the distal outlet of the jet system within the *alarm limits* set by the *healthcare professional operator* or generation of an *alarm condition*). The general standard requires *manufacturers* to declare accuracies and to address the associated *risks* in the *risk management process*. One of the associated *risks* is lack of consistency between *manufacturers* in their declarations of accuracy, both in terms of the reference settings used and the conditions of testing. Consistency in these situations can only be achieved by means of internationally agreed standards and these requirements have been formulated in order to fulfil this objective.

The test settings and conditions and, for certain parameters, minimum requirements, specified in this subclause have been selected by the committee as those necessary to demonstrate adequate *essential performance* of a *high-frequency ventilator* with regard to the parameters specified. The test *procedures* have been written as *type tests* (additional information is found in 3.135 and Clause 5 of the general standard), with the expectation that *manufacturers* will design their own test programmes to ensure that their declared accuracy tolerances for the settings and conditions specified will encompass any results obtained by a *type test* performed in accordance with the test *procedures* specified in this subclause.

#### **Subclause 201.12.1.101 – Mean airway pressure**

The test cases provided in Table 201.104 have been selected to provide coverage of the range of *patients* for whom high-frequency *ventilation* is appropriate.

The test case at 3,5 kg is selected as median term birth mass. The test cases at 8,0 kg and 45,0 kg are the breakpoints agreed by the Committees as appropriate for the division between infant and child *patient* groups, and between child and adult *patient* groups.

The test case at 80,0 kg is regarded as the largest foreseeable ideal body mass, noting that *ventilation* settings are based on ideal, and not actual, body mass.

The test case resistance is comprised of a tracheal tube (which can be modelled as a smooth bore tube with a specified internal diameter, length and radius of curvature) together with a linear resistance element representing the pulmonary resistance. The pulmonary resistance values are based on mouth-breathing pulmonary resistance by body weight.

#### **Subclause 201.12.1.104 – Response of the *ventilator* to an increase in set O<sub>2</sub> concentration**

It is important that changes in the delivered oxygen concentration can be made without major delay. This is especially relevant in cases where a rapid increase of the inspired oxygen concentration is necessary for *patient* care. For instance, it is common practice to preload the *patient* with high concentrations of oxygen for a brief period prior to open suctioning. Depending on the design of the *ventilator* and depending on the settings, significant delays can occur.

The committee could not develop a maximum delay as there are too many possible clinical scenarios. However, the *healthcare professional operator* needs to know how a *ventilator* will respond, particularly to a request for a sudden increase in oxygen concentration delivery.

As a result, a test method has been developed. When a *humidifier* is present, the minimum *humidifier* water level is required for the worst case for this test. The results of this test are required to be disclosed in the *instructions for use* so that a *healthcare professional operator* can effectively care for the *patient*.

#### **Subclause 201.12.4.102 – Measurement of *mean airway pressure* and low and high *mean airway pressure alarm conditions***

The site in the *VBS* at which pressure is sensed varies from *ventilator* to *ventilator*. Generally, the *manufacturer* chooses one of two strategies:

- measuring the *airway pressure* by direct sampling at the *patient-connection port* or at the distal outlet of the jet system; or
- indirectly estimating the pressure at the *patient-connection port* or at the distal outlet of the jet system by measuring the pressures at two locations in the *ventilator*, on the inspiratory side of the *VBS* (at the “to *patient*” port) and on the expiratory side of the *VBS* (at the “from *patient*” port), and, after mathematical manipulation, averaging the two values.

Even if the first strategy is chosen, the actual pressure transducer is located inside of the *ventilator enclosure* with narrow-diameter “plastic” tubing linking the pressure-sampling port at the *patient-connection port* to the sampling nipple on the pressure transducer. And for safety reasons, a separate transducer is typically used to measure the pressure on the inspiratory side at the “to *patient*” port. The displayed *airway pressure*, however, is always expected to estimate accurately the true value that would be measured at the *patient-connection port*. Pressure measurement via the first strategy accurately reflects the true *airway pressure* within the error of the pressure transducer.

#### **Subclause 201.12.4.106– *Maximum limited pressure protection device***

The value chosen for the *maximum limited pressure* <sup>[51][53][65]</sup> is a compromise between the need to avoid barotrauma and the need to provide an adequate range of pressure to meet the

therapeutic needs desired by *healthcare professional operators* to supply both high *mean airway pressure* and high *HFV* pressures for specific *patients* who have not responded favourably to optimal *ventilation-management* strategies aimed at *lung* protection and *lung* recruitment. In such cases the *healthcare professional operator* can, as a last resort, elect to ventilate using high *HFV* pressures.

High-frequency *ventilation* requires high gas flow rate to be provided during a very short duration *HFV inflation*. The peak flow (both inspiratory and expiratory) can be significantly higher than that typical in conventional *ventilation-modes*. Due to resistance to flow within the tracheal tube, this results in the need to provide oscillatory pressures at the *patient-connection port* or for *HFV* without a *patient-connection port* at the distal outlet of the jet system significantly greater than those observed within the trachea. The mean pressure in the *lungs* equilibrates (at least to an approximation) to the *mean airway pressure* (at the *patient-connection port*) over a period several times greater than the duration of an *HFV inflation*. To prevent the pressure in the *lungs* from exceeding the *maximum limited pressure* (even transiently), it is sufficient to prevent the *mean airway pressure* (averaged over the intended duration of one *HFV inflation*) from exceeding the *maximum limited pressure*. Therefore the *protection device* is required to activate only in the event that the *mean airway pressure*, averaged over the duration of an *HFV inflation* or 200 ms, exceeds the *maximum limited pressure*.

For a *ventilator* capable of operating in either conventional or *high-frequency ventilation-mode*, it is impractical to provide an instantaneous activation of the *protection device*. It is deemed appropriate to allow an activation time during conventional *ventilation-modes* that is consistent with the need to prevent *patient harm*. The duration of 200 ms is adopted consistent with the equivalent activation time defined in ISO 80601-2-12:2020 [23], 201.12.4.106 f).

It is noted that the *protection device* could be implemented with different design concepts.

A well established design concept is the use of simple mechanical pressure-relief valve within the inspiratory limb of the *HFV breathing system*.

A more sophisticated design concept is the use of an electro-pneumatic on-off valve in the inspiratory limb which is actively controlled to open in case that the value for the *maximum limited pressure* is reached.

For *ventilators* in which the pressure for *HFV ventilation* is generated by e.g. a centrifugal pump or a piston, the pressure limitation of the *protection device* can be achieved by the limited performance of the pressure source.

#### **Subclause 201.12.4.107 – High-pressure protection device**

In most other *ventilation* standards this is referred to as the *maximum limited pressure*. The *maximum limited pressure* is referenced to the *patient-connection port*. However, not all *HFVs* have a *patient-connection port*. As a result, this *protection device* does not reference the *maximum limited pressure*. Since there typically is no set pressure on an *HFV*, the 125 cmH<sub>2</sub>O requirement is exactly the same requirement as the requirement in ISO 80601-2-12:2020 [23].

#### **Subclause 201.12.4.109 – Disconnection alarm condition**

Disconnection of the *HFV breathing system* is a frequent event.

201.13.2.101 only addresses the disruption of the gas delivery to the *patient-connection port* or at the distal outlet of the jet system from the *ventilator* or, when present, disruption of the gas flow pathway from the *patient-connection port* or at the distal outlet of the jet system to the *ventilator*.

This subclause addresses other disconnections within the *HFV breathing system*. It doesn't address disconnection proximal to the *patient-connection port* (e.g., caused by an extubation). These kinds of disconnections have to be detected via other parameters like expired CO<sub>2</sub>.

It is recognised that disconnection leads to a loss of gas exchange, with the possibility of significant *harm* or death [57]. As an example, many current critical care *ventilators* generate a *technical alarm condition* when this occurs and the new revision of ISO 80601-2-12 [23] is adding a mandatory requirement to provide such a disconnection *alarm condition*.

Implementation of a disconnect *alarm condition* can use a variety of technological means to detect gas flow into and out of the *lungs*.

Where the disconnect *alarm condition* detection mechanism uses information from one or more external sensors, such as for expired CO<sub>2</sub>, the requirement from Clause 13 of the general standard for single fault safety applies. Loss of information from an external sensor would need to be assessed as a *single fault condition*.

An *HFV* is intended for use in the critical care environment or in the operating theatre. *HFV ventilation-modes* in general are intended for *ventilator-dependent patients*. These modes are mainly used when conventional *ventilation-modes* with *inflation rates* < 150 min<sup>-1</sup> doesn't provide sufficient oxygenation or CO<sub>2</sub> elimination.

In those cases where *patients* are not *ventilator-dependent*, disconnection does not require prompt attention from the *operator*. *Alarm fatigue* is well documented in the clinical setting [44], and can lead to delayed response to those *alarm conditions* that really are critical, including *alarm conditions* from the *ventilators* used for *ventilator-dependent patients* [48]. It is desirable to allow the *operator* to inactivate this *alarm condition* to avoid distracting caregivers from other more critical events.

This document does not address how the *operator* confirms whether a particular *patient* is *ventilator-dependent* prior to inactivating the disconnection *alarm signals*. Many implementations are possible. For example, this information can be captured during *patient* setup; or it can be included as a prompt during the *process* of inactivation. The *manufacturer* is required to assess the *usability* of their implementation in order to validate the effectiveness of their implementation.

#### **Subclause 201.12.101 – Protection against accidental or unintentional adjustments**

Unacceptable *risks* to the *patient* can occur as a result of accidental adjustments of operating controls or turning off the *ventilator*. To control this *risk*, the *operator-equipment interface* should be designed to prevent accidental adjustments. The *usability engineering process* is used to ensure that these *risks* are reduced to acceptable levels. Example methods could include mechanical *risk control* techniques such as locks, shielding, friction-loading and detents; pressure-sensitive finger pads; capacitive finger switches; microprocessor-oriented “soft” *risk controls*; and a specific sequence of key or switch operations.

#### **Subclause 201.13.101 – Additional specific single fault conditions**

**a)**

Disruption of the gas delivery to the *patient* independent of the root cause for the disruption (e.g., by disconnection or blockage of the inspiratory breathing / tubing system) is the most reasonably foreseeable event in the daily practice of *ventilation* around the world that might quickly lead to serious irreversible injury or the death of a *ventilator-dependent patient*.



**b)**

Disruption of the gas flow pathway between the *patient* and the *ventilator* independent of the root cause for the disruption (e.g., by disconnection or blockage of the expiratory breathing / tubing system) is the most reasonably foreseeable event in the daily practice that, depending on the *HFV breathing system* in use, might lead to pressure loss. This can lead to the inability to build up an *HFV breathing system* pressure sufficient to ventilate the *patient*, which in turn might lead to serious irreversible injury or the death of a *ventilator-dependent patient*.

**c)**

Operation of a *ventilator* without an *operator-detachable breathing system filter* in place is considered reasonably foreseeable when considering those parts of the *HFV breathing system* that might become contaminated with body fluids or by contaminants carried by expired gases. If a *ventilator* can operate without the *breathing system filter*, then one has to assume that it has been operated without the *breathing system filter* and therefore those parts of the *HFV breathing system* might have been contaminated. Additional information is found in the rationale for 201.11.6.6.

Increased resistance and blockage of a *breathing system filter* when used together with nebulization or humidification is also considered as failure of an *operator-detachable breathing system filter*.

**d)**

Operation of a *ventilator* using an *operator-detachable* remote control or monitoring module is considered as a state-of-the-art option today. Independent of how the communication between the “ventilator module” and the remote control or monitoring module is facilitated (e.g., wired or wireless) this communication needs to be so designed and constructed that a failure or loss of this communication does not cause an unacceptable *risk* to the *patient*. Further this communication (e.g., between the “ventilator module”, the remote control or monitoring module, the *distributed alarm system* or a simple remote *alarm signal* communicator) also needs to be designed to be *single fault safe*.

#### **Subclause 201.13.102 – Failure of one gas supply to a ventilator**

This subclause addresses the *hazardous situation* created when an entire unit (e.g., the whole critical care unit or all of the operating theatres) experiences simultaneous failure of multiple *ventilators* caused by the loss of a single pressurized gas source where at least one gas source is provided by a pressurized *medical gas pipeline system*.

**EXAMPLE 1** A *ventilator* is connected to both air and oxygen *medical gas pipeline systems* and one of the *medical gas pipeline systems* fails. The *ventilator* then uses the other *medical gas pipeline systems* to supply gas.

**EXAMPLE 2** A blower-based *ventilator* is connected to the oxygen *medical gas pipeline system* and that *medical gas pipeline system* fails. The *ventilator* then uses the room air provided by its blower.

In this circumstance, pressure and volume are maintained within specification but the oxygen concentration is not.

#### **Subclause 201.13.103 – Independence of ventilation control function and related risk control measures**

This requirement prevents the use of a monitoring device to control an actuator that would lead to an undetected malfunction of the actuator in case of monitoring failure.

**Subclause 201.13.104 – Failure of a *functional connection* to a ventilator control or monitoring means**

Independent of how the *functional connection* between the “ventilator module” and the remote control or monitoring module is facilitated (e.g., wired or wireless) this *functional connection* needs to be so designed and constructed that a failure or loss of the *functional connection* does not cause an unacceptable *risk* to the *patient*.

First of all, this means that the safety of the *patient* is not degraded by the loss of the *functional connection*, (i.e., the “ventilator module” continues to ventilate the *patient* without any change of the *ventilation* parameters, without any change of setting of safety means and without any change of the setting of *alarm limits*). Further, the *healthcare professional operators* in both locations where these modules are located need to be made aware by *alarm signals* about the loss of this *functional connection* (i.e., there is a need for *alarm signals* on both sides of the *functional connection*—at the “ventilation module” and on any other remote control or monitoring module or the *distributed alarm system* or the simple remote *alarm signal* generator).

**Subclause 201.15.3.5.101.1 – Shock and vibration (robustness)**

The intention of these tests is to assess mechanical stresses on the *ventilator* in *normal use* and not to assess the suitability of the design for the *expected service life* or fatigue.

*ME equipment*, including *ventilators*, in *normal use*, used within a *professional healthcare facility*, will be subjected to mechanical stresses (e.g., vibration, shock) and could randomly be subjected to additional stresses. Therefore, *ME equipment* intended to be used in a *professional healthcare facility* needs to be robust enough to withstand the vibration and shock testing described by IEC 60721-3-7 [32] level 7M1. IEC 60721-3-7 indicates that this class applies to within, and direct transfer between, locations with only low-level vibrations, or with medium-level shocks. Careful handling and transfer of products is expected in these environments.

In reviewing the random vibration tests of IEC 60068-2-64:2008, the committee determined that the environment included careful handling in vehicles (including airborne vehicles). Since a *high-frequency ventilator* is not intended for such environments, the maximum frequency of the acceleration amplitude was limited to 500 Hz which is more reflective of non-vehicle environments.

**Subclause 201.15.3.5.101.2 – Shock and vibration for a *transit-operable ventilator* during operation**

*Transit-operable ventilators* (those intended to operate while the *patient* is being transported within a healthcare facility) are expected to maintain *basic safety* and *essential performance* while they are being moved. Some degradation is permitted, but the *patient* is expected to continue to be adequately and safely ventilated. Rationale for 202.6.2.1.10 contains additional information regarding appropriate acceptance criteria for *essential performance*.

**Subclause 201.101.1 – Protection against reverse gas leakage**

These requirements are necessary to maintain *patient* safety by protecting the *medical gas pipeline system* from contamination via reverse flow.

The basic requirements of this subclause were introduced into standards more than a decade ago because of the *harm* due to reverse gas leakage that was known to have occurred in connection with medical devices that use multiple gas sources.

With devices fitted with multiple *high-pressure inlets* for the same gas, the *hazardous situation* results from the undetected loss of backup gas supplies due to back leakage into the primary

supply. With *high-pressure inlets* for different gasses, the *hazard* is contamination of one gas source by gas from another source. The contamination *hazard* is particularly likely to occur while the medical device is left in a condition where it is connected to the gas supplies but is not drawing flow from the gas supply system.

*Ventilators* are frequently equipped with multiple *high-pressure inlets* either to achieve a greater flow or to use a local backup supply (e.g., a gas cylinder) in parallel with a *medical gas pipeline system* supply. With such systems the backup supply could be depleted prematurely during use or, when connected but not in use, could deplete without detection and not be available when required in an emergency.

With a *ventilator* equipped with more than one different *high-pressure inlet*, even very small leakages from one of the gas systems to the other can cause considerable contamination in a *medical gas pipeline system* over extended periods during which little flow is withdrawn.

More than 10 y of experience has demonstrated that these requirements are effective *risk control* measures.

#### **Subclause 201.101.2.2 – Filter**

The intention of filtration of the gas from the *high-pressure inlet* is to protect the sensitive components (e.g., flow sensors) of the *ventilator gas pathways* from particles. This gas is provided from *medical gas pipeline systems* or from gas cylinders.

The standards for high-pressure oxygen compatibility <sup>[19]</sup> and pressure regulators <sup>[12]</sup> require input filtering that prevents particles greater than 100 µm from entering.

Despite these requirements particles with larger sizes could come from:

- particles collected in *high-pressure inlets* and port connectors;
- *high-pressure inlets* of *ventilators* while disconnected; or
- malfunction of *medical gas pipeline systems*, medical air compressors, oxygen concentrators or filters.

Depending on the design of a specific *ventilator* (e.g., in case that particle-sensitive sensors are used) significantly smaller filter sizes than 100 µm can be required.

#### **Subclause 201.101.3.1 – General**

Non-standard *HFV breathing system* connectors can represent an unacceptable *risk* as attempts are made to fit a standard *HFV breathing system* to a *ventilator* in an emergency situation. Non-standard *HFV breathing system* connectors can cause leaks or disconnections if used with similar but not compatible connectors.

#### **Subclause 201.101.3.2.5 – Accessory port**

Whilst there are many anecdotal reports of misconnections, published evidence of serious incidents is scarce. Many clinicians openly admit that misconnections are commonplace but go unreported either because the mistake was rectified in time or because serious *harm* did not arise from the event. Discussions with *authorities having jurisdiction* reveal that commonplace but potentially serious events are not reported because users consider them as normal events.

In the *risk assessment* of the *ventilator breathing system* and its connectors, it can be summarised that there are fundamentally three main routes of delivery to the body: intravascular, enteral and respiratory. Some medical devices are intended to be connected to one of these routes depending

upon their application or function. Misconnections, which result in the delivery of a substance inappropriately to the body, create *risks* to the *patient*.

The assessment of the *risk* associated with the inadvertent cross connection between these three systems identifies the application of respiratory gases to the delivery route intervascular as “immediate fatal risk to patient”.

Considering *usability*, a review of the role of *usability* in accident areas such as aviation, nuclear power and marine transportation exists [42]. The review makes the point that all human beings, without any exceptions whatsoever, make *use errors* and that such *use errors* are a completely normal and an expected part of human cognitive function. The review goes on to say that whilst many accidents are regarded as human error (which is synonymous with *use error*) the guilty party can often be someone else, for example the trainer, the equipment designer, the equipment purchaser etc. Well-designed equipment can prevent or at least ameliorate the effects of *use error*. The review states that one must expect users to misconnect devices which are provided with compatible connectors, and recognise that the potential for misconnection rises as the number of devices with similar connectors increases.

Considering further that medical devices have for very many years followed the established principle of safety under *single fault condition*, which means that a *single fault condition* should not result in an unacceptable *risk*. This principle is also embodied in IEC 60601 family of standards. Extending this principle to the application of Luer connectors is a logical step (i.e., that misconnection should not result in an unacceptable *risk*).

Misconnection of medical devices with Luer connectors is a frequent event. The widespread use of Luer connectors on a multitude of medical devices can therefore result in connections which have serious, or even fatal, consequences for the *patient*. Fundamentally, the problem results from the application of a single connector design to several incompatible applications.

Claims of a lack of recorded misconnection occurrence indicate a lack of understanding *risk* and *usability*. It's known that most of the actual occurrences are recorded not as medical device failures and if anything, are seen as wrong route of delivery issues – not as misconnections. Human beings without exceptions make errors. We therefore expect *operators* to misconnect medical devices that are provided with compatible connectors. The safety concept of the ISO 80369 series is based on the principle that the different applications protect each other by an inherent design of the connectors dedicated to their field of application i.e., the safety concept of the ISO 80369 series is to prevent users from misconnecting medical devices of different applications.

This leads to the clear conclusion that Luer taper or Luer-lock connectors conforming with ISO 594-1 [1], ISO 594-2 [2] or ISO 80369-7 [22] are unsafe and therefore are not permitted for use for connection the *gas pathways* of an *HFV breathing system*.

#### **Subclause 201.102.1 – General**

It is the responsibility of the *manufacturer* of an *HFV breathing system*, its parts or *accessories* to verify that their product conforms with the requirements of this document.

#### **Subclause 201.102.4 – Water vapour management**

Water management refers to the complete *process* by which moisture, in the form of water vapour, is added to the breathing gas delivered to the *patient's lungs* and the *process* by which humidified breathing gas is conducted back to the *ventilator's* expiratory system and exhausted to the room. Intrinsic to this *process* is the necessity to remove bulk water due to condensation of moisture attributable to pressure and temperature changes in the *HFV breathing system*. Even if breathing

gas reaches the *patient-connection port* or the distal outlet of the jet system without any added moisture, the expired breathing gas directed back to the *ventilator* will contain some moisture. Water management in the *HFV breathing system* requires attention, whether or not the *HFV breathing system* contains an active *humidifier*, with or without heated wires in the inspiratory or the expiratory limbs of the *HFV breathing system*.

Proper management of the *patient's* airway secretions and mucociliary transport system requires that the *ventilator* compensate for the humidity deficit caused by intubation, which bypasses the upper airways where the normal humidification *process* would begin. Excess moisture delivered to the *patient-connection port* or at the distal outlet of the jet system can flood the cilia located in the bronchial airways, diminishing their ability to move mucus toward the trachea. On the other hand, insufficient humidification of the inspired breathing gas dries the bronchial airways, which leads to thickening of the mucous secretions and likely increased airway resistance or worse. A balanced approach to humidification is needed to maintain healthy cilia. Liquefied mucus can be readily aspirated using a *suction catheter*.

Optimal humidification of the *patient's* airways results from an understanding of the physics of the techniques chosen to add water vapour to the inspiratory gas stream. Depending on the system selected for delivering humidified breathing gas to the *patient* (for example, active vapour *humidifier* with or without heated wires, conventional heat and moisture exchanger (HME) or active HME), condensate can accumulate in the inspiratory limb of the *HFV breathing system*. If condensation occurs, the *HFV breathing system* will need to provide a method by which the liquid can be removed.

In all but the most unusual circumstances, gas leaving the alveoli is saturated at 37 °C. Rainout persists as the moist gas cools and moves toward the *patient-connection port* or the distal outlet of the jet system, and is conducted back to the *ventilator*. If an HME is fitted at the *patient-connection port* or at the distal outlet of the jet system, approximately 50 % to 70 % of the water vapour will be trapped in the HME. Whatever the configuration of the expiratory limb of the *HFV breathing system*, the water vapour content of the exhaled gas will be significant, nearing saturation. Without heated wires, the returning gas cools, causing significant condensation. As in the inspiratory limb, this liquid needs to be removed. The presence of heated wires in the expiratory limb lessens or eliminates condensation before the expired gas enters the *gas return port* of the *ventilator*, but from this point to the *exhaust port* the gas tends to cool further, so more moisture will condense. The *HFV breathing system* needs to include some means to manage this additional condensed water.

#### **Subclause 201.102.6 – Leakage from the complete VBS**

Not all *HFVs* are intended for use with an *HFV breathing system* that operates at pressures comparable to those in the *lungs*, with a *patient-connection port* close to the *patient* for connection to an *airway device*.

For those *HFVs* that do use this configuration, the *operator-detachable* parts of the *HFV breathing system* are frequently third-party *accessories*. The inclusion of constructional requirements that limit leakage ensures that leakage from the assembly of these components creating the *HFV breathing system* does not degrade the *basic safety* or *essential performance* of the *HFV*. For this class of *HFV*, the requirements provided in ISO 80601-2-12 <sup>[23]</sup>, 201.102.7.1, have been determined to be appropriate.

Generic requirements for the *operator-detachable* parts of the *HFV breathing system* are not appropriate for those *HFVs* that:

- use a high resistance *applied part*;

- do not have a *patient-connection port* (i.e., are integrated into the *HFV breathing system*); and
- are not intended to operate at respiratory pressure.

The *manufacturer* would be expected to manage any potential *hazards* associated with leakage from the *operator-detachable parts* of the *HFV breathing system* through their *risk management process*.

Assuming that the leakage flow can be modelled as if an ideal orifice were producing it, then the leakage flowrate,  $Q_{leak}$ , would follow Formula (AA.4).

$$Q_{leak} = G \times \sqrt{P} \tag{AA.4}$$

where

$G$  is the orifice conductance; and

$P$  is the driving pressure.

Using the leakage limits from this document and Formula (AA.4), the orifice conductance  $G$  can be calculated for each of the *patient weight ranges*. For example, the leakage limit for a *patient weight*  $\geq 45$  kg is 200 ml/min at a pressure of 50 cmH<sub>2</sub>O, which yields a value for  $G$  of 28,28 ml/(min·hPa<sup>1/2</sup>). Conductance values for the other *patient weight ranges* can be similarly calculated. Table AA.1 summarizes these results.

**Table AA.1 — Calculated conductance values by *patient weight range***

<i>Patient weight range</i> kg	Leakage limit from ISO 80601-2-12:2020 [23] ml/min	Pressure, P hPa (cmH <sub>2</sub> O)	Calculated conductance, G ml/(min·hPa <sup>1/2</sup> )
Weight $\leq 8$	50	20	11.18
$8 \leq$ Weight $\leq 45$	100	40	15,81
Weight $\geq 45$	200	50	28,28

Using these calculated conductances, it is then possible to find the corresponding *VBS leakage limit* at any pressure. Figure AA.2 demonstrates these relationships.

Using Figure AA.2, one can derive the 60 hPa (60 cmH<sub>2</sub>O) *VBS leakage flowrate limits*. This is the pressure at which most of the *operator-accessible parts* of the *VBS* are specified for leakage flowrate.

- for *patient weight*  $\leq 8$  kg,  $Q_{leak} = 87$  ml/min
- for  $8$  kg  $\leq$  *patient weight*  $\leq 45$  kg,  $Q_{leak} = 122$  ml/min
- for *patient weight*  $\geq 45$  kg,  $Q_{leak} = 219$  ml/min

These leakage flowrate limits represent the permissible leakage of the entire *HFV breathing system*. It is common to allocate 90 % of the leakage flowrate to the *operator-accessible parts* of the *HFV breathing system* and 10 % to the parts of the *HFV breathing system* internal to the *ventilator*.

### Subclause 201.103 – Spontaneous breathing during loss of power supply

Electrical or pneumatic power outside the values required for normal operation can affect all *ventilators* in a given unit. This is not limited to a loss of power but can also include excessive power. Although this is an infrequent event, it constitutes a particularly difficult situation because many or all *ventilators* can become simultaneously compromised. It is therefore imperative that a *patient* can breathe spontaneously under these conditions until alternative *ventilation* is provided.

Previous standards for critical care *ventilators* have required that the pressure drop be less than 6 hPa (6 cmH<sub>2</sub>O) at 60 l/min for adults. *Patients* in a critical care unit usually don't generate such high inspiratory flows. Considering this and that *accessories* can be placed in the *HFV breathing system*, the committee came to the conclusion that this value is unnecessarily design-restrictive. In addition, spontaneous breathing is only needed to bridge the time until alternative *ventilation* is provided. The committee came to the conclusion that a mere disclosure is not sufficient. The chosen values are regarded as more realistic and sufficient for this infrequent event and were tailored to the intended range of *inspiratory volumes*.

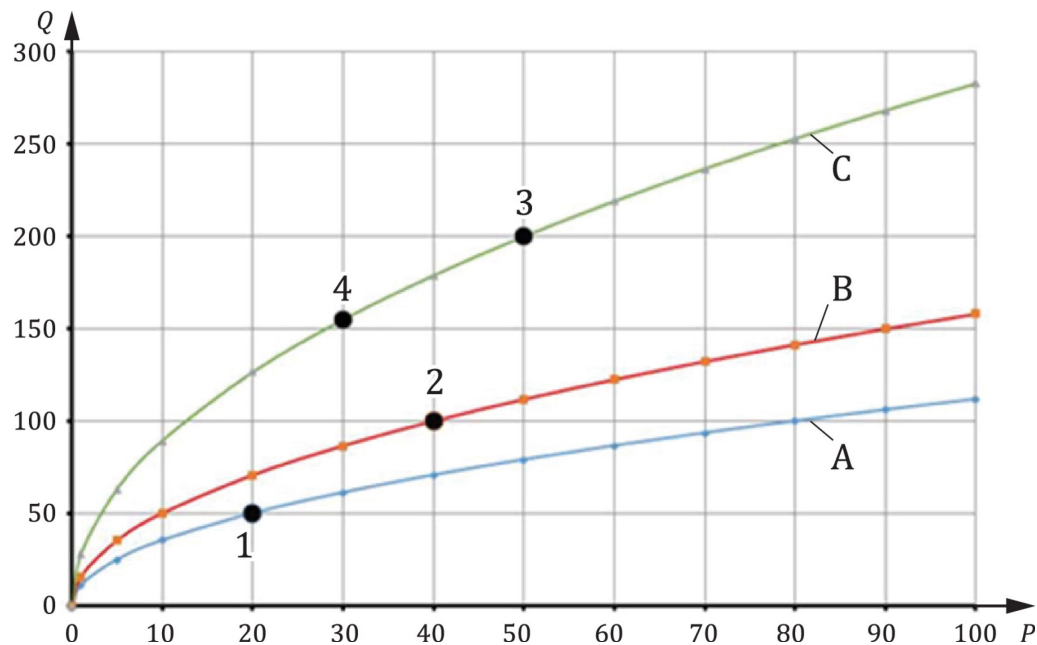

#### Key

- 1 leakage limit from ISO 80601-2-12 [23] for  $V_{del} \leq 50$  ml
  - 2 leakage limit from ISO 80601-2-12 [23] for  $50 \text{ ml} \geq V_{del} \geq 300$  ml
  - 3 leakage limit from ISO 80601-2-12 [23] for  $V_{del} \geq 300$  ml
  - 4 leakage limit from ISO 80601-2-13 [24]
- A (blue) -  $Q_{leak}$  for  $V_{del} \leq 50$  ml  
 B (red) -  $Q_{leak}$  for  $50 \text{ ml} \geq V_{del} \geq 300$  ml  
 C (green) -  $Q_{leak}$  for  $V_{del} \geq 300$  ml

NOTE This assumes leakage behaves as an orifice according to Formula (AA.4).

**Figure AA.2 — Breathing system leakage flowrate limits as a function of pressure as specified in ISO 80601-2-12 [23] and ISO 80601-2-13 [24]**

#### **Subclause 201.104 – Indication of duration of operation**

*Ventilators* require maintenance for continued safe use. A practicable means to ensure that this information is available to the *operator* or the *responsible organization* is to require that the *ventilator* keep track of how long it has been in operation.

#### **Subclause 201.105.2 – Connection to an electronic health record**

Electronic documentation of *patient* care interventions is rapidly becoming the standard of care. The primary motivations are to improve the quality of care for an individual *patient* through accurate and complete documentation, and to improve the completeness and accuracy of aggregate data to facilitate continuous quality improvement. In some countries, there is a governmental directive to provide electronic health records [41]. Electronic data transmission to the electronic health record is essential to meet this requirement. Annex BB contains information that *manufacturers* can find useful as requirements for data interfaces.

The data transmission should be capable of being provided with such a *functional connection* in accordance with AAMI 2700-1:2019 [36] or ISO/IEEE 11073-20701:2020 [16].

#### **Subclause 201.105.3 – Connection to a distributed alarm system**

*Patients* who are *ventilator-dependent* are usually located in clinical environments that are staffed with *healthcare professional operators* in sufficiently close proximity to hear *alarm signals* coming from the *patient's* room. However, the layout of some critical care units is such that a *distributed alarm system* is needed to ensure that the *operator* can hear the *alarm signal*. *Patients* also can be in enclosed (positive or negative pressure) isolation rooms. In these settings, it can be difficult or impossible for *healthcare professional operators* to hear *alarm signals*. As a result, an appropriate response can be delayed with catastrophic results. A *distributed alarm system* facilitates delivery of *alarm signals* to remotely located *healthcare professional operators*, thereby permitting a timely response and intervention to support *patient* care [35].

The data transmission should be capable of being provided with a *functional connection* in accordance with AAMI 2700-1:2019 [36] or ISO/IEEE 11073-20701:2020 [16].

#### **Subclause 202.4.3.1 – Configurations**

It is not the intent of the committee to require that the *immunity* tests be performed multiple times (e.g., with *volume-control inflation-type* and *pressure-control inflation-type* at several *inspiratory volumes*), but that the *manufacturer* should determine which *inflation-type* and *inspiratory volume* represents the worst case for a given *immunity* test and use those conditions.

#### **Subclause 202.8.1.101 – Additional general requirements**

The committees recognized that during environmental stress (for example, shock, vibration, electromagnetic disturbances) *ventilator* performance can degrade. In such a situation, the duration of altered performance can vary from less than one minute to tens of minutes.

The question then became how to express the percent change in pressure and volume performance that would not cause *harm* to a *patient* during a brief interval of environmental stress. In today's neonatal intensive care unit (NICU) environment of Lung Protective Ventilation (LPV), the maximum setting for neonatal and paediatric *patients* (tidal volumes of 2 ml/kg) would be a *mean airway pressure* of 25 hPa (25 cmH<sub>2</sub>O) and a *pressure amplitude* of 80 hPa (80 cmH<sub>2</sub>O). The volumes generated by these settings are dependent on the *patient's* resistance and compliance, but correspond to what is required for a 5 kg baby [49].



The committees agreed that the parameters indicated below would represent an acceptable *risk* for the *patient*.

For *mean airway pressure*, where a rapid increase could cause barotrauma it is acceptable to have a variation up to 25 % or 5 hPa averaged over 10 s, compared to the value prior to when the *ventilator* is subjected to the stress. As an example; the typical maximum clinical setting for *mean airway pressure* is 25 hPa which would correspond maximum acceptable *mean airway pressure* of 30 hPa during stressed conditions. Given that the maximum duration of a few tens of minutes (i.e.,  $\leq 30$  min) a *patient* would be expected to tolerate these deviations without undue *risk*. For durations longer than 10 s, the tolerances are according to 201.12.1.101.

For *HFV volume*, which has a substantial impact on CO<sub>2</sub> exchange, it is acceptable to vary up to 25 % averaged over 1 min, compared to the value prior to when the *ventilator* is subjected to the stress. A worst case for variation of the *HFV volume* with a decrease of 25 %, could cause, based on the *patient*, a shorter decrease in O<sub>2</sub> saturation. For the purpose of the *verification* of this requirement the *HFV volume*, if not set or presented as a parameter, should be generated by setting an appropriate *HFV frequency* and *HFV pressure amplitude* based on a *patient's* resistance and compliance. The deviation would then correspond to 2.5 ml for a 5 kg baby, which is not be considered hazardous. For durations longer than 1 min, the tolerances are according to 201.12.4.105.

For the O<sub>2</sub> concentration it is acceptable to deviate up to 25 % averaged over 1 min compared to the value prior to when the *ventilator* is subjected to the stress, for the same reason as for *HFV volume* <sup>[46]</sup>.

### **Subclause 206.102 – Training**

The modern *high-frequency ventilator* is a complex life-sustaining *ME equipment* whose use requires specific training for each *manufacturer's* make and model. Different *manufacturers* often refer to similar *ventilation-modes* by different names, and, although in principle similar to another *manufacturer's ventilator*, their *ventilation-mode* is unique in sometimes minor and sometimes complex ways. It is essential, therefore, that however experienced the *operator*, every person involved with its operation and setup is fully trained in the *ventilator's* operational characteristics, in particular its controls, capabilities and limitations, prior to any use.

### **Subclause 208.6.8.4.101 – Additional requirements for termination of alarm signal inactivation**

Permitting very long pauses of *alarm signals* can be hazardous for the *patient* since the *healthcare professional operator* will not be notified of the existence of an *alarm condition*. However, *patient* management often requires delicate *procedures* that can be disrupted by auditory *alarm signals*. Therefore, extending *audio paused* by *healthcare professional operator* action is useful to prevent the *ventilator* from disturbing the *healthcare professional operator* or others in the vicinity (e.g., surgeon or cardiologist) in the *patient's* room.

*Ventilators* should be equipped with an *audio paused* capability that permits the *healthcare professional operator* to pause the auditory *alarm signals* prior to the creation of an *alarm condition*. Such a capability permits the *healthcare professional operator* to minimize nuisance auditory *alarm signals* in situations that are known to be associated with creation of nuisance *alarm conditions*. A 'planned' disconnect is a common situation where this capability is needed. Examples include open suctioning, *breathing system filter* change, or insertion of a medication treatment. A closed suctioning *ventilator operational mode* should also include such a capability.

**Subclause 208.6.12.101 – Additional requirements for *alarm system* logging**

Optimal management of a *patient* requires the capability to review the history of important *alarm conditions*. This is a more reasonable means of *risk control* in the critical care environment than *latching alarm signals*. Additional information is found in IEC 60601-1-8:2006+AMD1:2012, Annex A, 6.12 – *alarm condition* logging.

## Annex BB (informative)

### Data interface requirements

#### BB.1 Background and purpose

Heightened interest in the monitoring of *ventilators*, as well as accountability and responsiveness of the parties involved, has become evident on an international scale. Consequently, *patients*, caregivers, clinicians, service providers, and payers have begun the systematic definition and collection of information with regard to monitoring the performance of this type of *ventilator*. This trend is also driven by an enhanced data infrastructure. In order to establish a common definition for monitoring the ventilatory performance of the *ventilator*, explicit criteria need be applied to choosing and defining parameters. This framework is intended to provide a common definition of parameters for *ventilators*. The selection is based on the agreement of the committees about what is to be monitored and for what purpose.

It is important to note that any data collection needs to be carried out according to privacy and confidentiality requirements and ethical principles.

A harmonized effort to develop internationally accepted therapy indicators for *ventilators* not only fosters increasingly robust cross-national analyses, but can also facilitate the development of comparable data that can be used as a basis for the setting of international benchmarks.

The standardization of data available from *ventilators* is intended to help to eliminate current shortcomings and significantly contribute to the improvement of the therapy. This approach seeks to provide a definition that can be used across *ventilator* therapy systems for providing therapy data independent of *ventilator manufacturer* or what mechanisms are used to transport the data, either locally or remotely to a *healthcare professional*. This approach ensures comparability between data regardless of the transport mechanism chosen to be most appropriate for a *patient* situation. It also provides for flexible and cost-effective integration into disparate systems that *healthcare professionals* can use for *patient* data management. This approach also maintains comparability between data while allowing advancement in data transport technology to provide solutions that better meet the needs of *patients*, caregivers, clinicians, service providers and payers. As such, the definition of specific device communication interface hardware or software considerations such as protocols or transport mediums is outside of the scope of this document.

A number of monitoring requirements for *ventilators* require various types and levels of data (e.g., different levels of detail) depending on the needs of the *patient*, caregiver, clinician, service provider, and payer. This document seeks to define the data that are required to meet the needs of these individuals.

The following data are defined.

- **Parameters and units of measurement:** Parameters and units of measurement used in the *ventilator*.
- **Equipment identification:** Information identifying the *ventilator*.
- **Usage monitoring:** Temporal data relating to the use of the *ventilator*.

- **Equipment settings:** The different *ventilation-modes* provided by *ventilators* that require different settings.
- **Ventilation monitoring:** Information related to monitoring of *patient ventilation*.
- **Ventilator alarm limits:** Settings relating to *ventilation-related alarm limits*.
- **Event information:** Information provided about events related to the usage of the *ventilator*.
- **Service monitoring:** Indicators relating to preventative or corrective maintenance of the *ventilator* and its *accessories*.

All *ventilators* should provide the information to enable identification of the *ventilator*. Implementation of any further data levels is optional.

Information identifying pressure units used in the data set should also be provided.

## BB.2 Data definition

Table BB.101 defines information, which identifies units of measurement in the data set.

**Table BB.101 — Parameters and units of measurement**

Parameter	Description	Type
Pressure units	Specification of the units of measurement for pressure-related data	Value: (cmH <sub>2</sub> O or hPa)
Flowrate units	Specification of the units of measurement for flowrate-related data	Value: (l/min or l/s)
Volume units	Specification of the units for volume-related data	Value: (ml or l)
<i>Spontaneous breath rate</i>	Specification of the units for <i>spontaneous breath rate</i>	Value: (breaths/min)
<i>HFV frequency</i> units	Specification of the units for <i>HFV frequency</i>	Value: (inflations/s)
<i>Inspiratory time</i> units	Specification of the units for <i>inspiratory time</i>	Value: (s or ms)
Leakage units	Specification of the units for leakage	Value: (ml/min)

Table BB.102 defines *ventilator* identification data.

**Table BB.102 — Equipment identification**

Parameter	Description	Type
Equipment <i>manufacturer</i>	Identification of the <i>manufacturer</i> of the equipment	Text string
Equipment model	Identification of the product or model number of the equipment	Text string
Equipment UDI	Unique device identifier (UDI)	Text string
Equipment serial number	Identification number of the equipment	Text string
Equipment software version	Identification of the software version(s) implemented in the equipment	Text string
NOTE More than one software version can be needed to be communicated from the equipment.		

Table BB.103 defines data required for usage monitoring.

A set of measured and calculated values should be provided for each *ventilation* session, where a *ventilation* session is any period of time the *ventilator* is providing *ventilation*.

**Table BB.103 — Usage monitoring**

Parameter	Description	Type
<i>Ventilation</i> start date/time	The current UTC (coordinated universal time) date and time when the usage session was started	ISO 8601-1 [6] Date Time (YYYY-MM-DDThh:mm:ss)
<i>Ventilation</i> stop date/time	The current UTC (coordinated universal time) date and time when the usage session was stopped	ISO 8601-1 [6] Date Time (YYYY-MM-DDThh:mm:ss)
Hours of <i>ventilation</i>	Number of hours the equipment is powered on and providing <i>ventilation</i> for the usage session	Value: (h)
Hours of <i>patient</i> use	Number of hours the equipment is providing therapy to the <i>patient</i> for the usage session	Value: (h)

Table BB.104 defines applicable current settings of the *ventilator* for each *ventilation -mode*.

**Table BB.104 — Equipment settings**

Parameter	Description	Type
<i>Ventilation-mode</i>	<i>Ventilation-mode</i> systematic code as defined within the standard	Type selected
<i>Patient</i> category	<i>Patient</i> cohort classification	Type selected
Airway interface	Airway interface classification — invasive — non-invasive	Type selected
<i>HFV</i> breathing system	Type of <i>HFV</i> breathing system used double limb with patient connection port; single limb without patient connection port – ‘open system’	Type selected: Text string

Parameter	Description	Type
Language	Identification of the user interface language setting according to ISO 639-1:2002 <sup>[3]</sup>	Value: (2-letter alpha)
Display brightness	Setting of the luminous intensity as a percentage of the maximum setting	Decimal (2-digit %)
<i>Mean airway pressure</i>	Setting of the <i>mean airway pressure</i> (if applicable)	Value: (cmH <sub>2</sub> O or hPa)
<i>Pressure amplitude</i>	Setting of the <i>pressure amplitude</i> (if applicable)	Value: (cmH <sub>2</sub> O or hPa)
<i>HFV volume</i>	Setting of the <i>HFV volume</i> (if applicable)	Value: (mL)
<i>HFV frequency</i>	Setting of the <i>HFV frequency</i>	Value: (inflations/s)
<i>I:E ratio</i>	Ratio of the duration of the <i>inspiratory time</i> to the duration of the expiratory time	Value: (I:E)
O <sub>2</sub> measurement activation	Information about the activation of the inspiratory oxygen measurement	Boolean (True if activated, otherwise false)
Expiratory volume measurement activation	Information about the activation of the expiratory tidal volume measurement	Boolean (True if activated otherwise false)

Table BB.105 defines the indicators relating to monitoring of *patient ventilation*.

**Table BB.105 — Ventilation monitoring**

Parameter	Description	Type
High <i>mean airway pressure</i>	Highest <i>mean airway pressure</i> during <i>ventilation</i>	Value: (cmH <sub>2</sub> O or hPa)
Low <i>mean airway pressure</i>	Lowest <i>mean airway pressure</i> during <i>ventilation</i>	Value: (cmH <sub>2</sub> O or hPa)
High <i>pressure amplitude</i>	Highest peak-to-peak <i>pressure amplitude</i> during <i>ventilation</i>	Value: (cmH <sub>2</sub> O or hPa)
Low <i>pressure amplitude</i>	Lowest peak-to-peak <i>pressure amplitude</i> during <i>ventilation</i>	Value: (cmH <sub>2</sub> O or hPa)
High FiO <sub>2</sub>	Highest inspiratory oxygen concentration	Value: (% O <sub>2</sub> V/V)
Low FiO <sub>2</sub>	Lowest inspiratory oxygen concentration	Value: (% O <sub>2</sub> V/V)
High <i>HFV volume</i>	Highest <i>HFV volume</i> delivered by the <i>ventilator</i>	Value: (ml)
Low <i>HFV volume</i>	Lowest <i>HFV volume</i> delivered by the <i>ventilator</i>	Value: (ml)
High <i>expired minute volume</i>	Highest <i>expired minute volume</i> delivered by the <i>ventilator</i>	Value: (l/min)
Low <i>expired minute volume</i>	Lowest <i>expired minute volume</i> delivered by the <i>ventilator</i>	Value: (l/min)
High <i>HFV frequency</i>	Highest rate of inflations delivered by the <i>ventilator</i>	Value: (inflations/s)
Low <i>HFV frequency</i>	Lowest rate of inflations delivered by the <i>ventilator</i>	Value: (inflations/s)
<i>I:E ratio</i>	Ratio of the duration of the <i>inspiratory time</i> to the duration of the expiratory time	Value: (I:E)
Total leakage	Loss of respiratory gas from the <i>VBS</i> and the <i>patient</i> during the <i>respiratory cycle</i>	Value: (ml/min or %)

Table BB.106 defines the applicable current *alarm limits* of the *ventilator*.

**Table BB.106 — Ventilator alarm limits**

Parameter	Description	Type
High inspiratory pressure <i>alarm condition</i>	Setting of the <i>alarm limit</i> for high pressure	Value: (cmH <sub>2</sub> O or hPa)
Low inspiratory pressure <i>alarm condition</i>	Setting of the <i>alarm limit</i> for low pressure	Value: (cmH <sub>2</sub> O or hPa)
High FiO <sub>2</sub> <i>alarm condition</i>	Setting of the <i>alarm limit</i> for high inspiratory oxygen concentration	Value: (% O <sub>2</sub> V/V)
Low FiO <sub>2</sub> <i>alarm condition</i>	Setting of the <i>alarm limit</i> for low inspiratory oxygen concentration	Value: (% O <sub>2</sub> V/V)
High HFV volume <i>alarm condition</i>	Setting of the <i>alarm limit</i> for high HFV volume	Value: (ml)
Low HFV volume <i>alarm condition</i>	Setting of the <i>alarm limit</i> for low HFV volume	Value: (ml)
Leak <i>alarm condition</i>	Setting of the <i>alarm limit</i> for high unintentional leak	Value: (l/min or %)

Table BB.107 defines applicable *ventilator* usage information.

**Table BB.107 — Event information**

Parameter	Description	Type
Power supply source	Current source of electrical power — external AC <i>supply mains</i> — internal <i>electrical power source</i> — external DC <i>supply mains</i>	Type in use
<i>Alarm signal</i> inactive state present	List of text strings ( <i>alarm off, alarm paused, audio off, audio paused, acknowledged</i> )	List of text strings
<i>Active alarm condition</i>	Currently active <i>alarm conditions</i>	List of text strings ( <i>manufacturer-defined</i> )
Access mode	Current access mode of the <i>ventilator</i> — <i>lay operator</i> — supervising clinician or the <i>healthcare professional operator</i> — <i>responsible organization</i>	Type in use

Table BB.108 defines applicable service and maintenance parameters.

Table BB.108 — Service monitoring

Parameter	Description	Type
Maintenance needed	A <i>manufacturer</i> -specific list of any items requiring maintenance (e.g. <i>mask</i> , tubing, filter)	List of text strings ( <i>manufacturer</i> -defined)
<i>Ventilator</i> service indicator	An indication that service is required	Text string: ( <i>manufacturer</i> -defined)
Hours of <i>ventilation</i>	Number of hours the equipment is powered on and providing <i>ventilation</i>	Value: (h)
Hours until next scheduled maintenance	The next <i>manufacturer</i> -specified suggested maintenance interval	Value: (h)



## Annex CC (informative)

### Reference to the IMDRF *essential principles* and labelling guidances

This document has been prepared to support the essential principles and labelling requirements of a *ventilator*, its *accessories* or parts as medical device according to the International Medical Device Regulators Forum (IMDRF). This document is intended to be acceptable for conformity assessment purposes.

Conformance with this document provides one means of demonstrating conformance with the specific *essential principles* of IMDRF/GRRP WG/N47:2018<sup>[39]</sup> and labelling principles IMDRF/GRRP WG/N52:2019<sup>[40]</sup>. Other means are possible. Table CC.1 maps the clauses and subclauses of this document with the essential principles of IMDRF/GRRP WG/N47:2018. Table BB.2 maps the clauses and subclauses of this document with the labelling principles of IMDRF/GRRP WG/N52:2019.

NOTE 1 When an essential principle does not appear in Table CC.1, it means that it is not addressed by this document.

**Table CC.1 — Correspondence between this document and the *essential principles***

<i>Essential principle of IMDRF/GRRP WG/N47:2018</i> <sup>[39]</sup>	<b>Corresponding clause(s)/ sub-clause(s) of this document</b>	<b>Qualifying remarks/Notes</b>
5.1	All	The part relating to manufacturing is not addressed
5.1.3	201.4, 201.4.3.101	
	a) 201.4, 201.4.3.101	
	b) 201.4, 201.4.3.101, 201.11.8.101, 210.12.4	
5.1.4	201.7	
5.1.5	—	
	a) 201.12.1, 206	
	b) 206	
5.1.6	All	
5.1.7	201.4	
5.1.8	201.4	
5.1.9	201.4	
5.3.1	—	
	a) 201.11.7	
	b) 201.11.6.6	
	d) 201.15.3.5.101	
	e) 201.11.6.6. bb)	

<i>Essential principle of IMDRF/GRRP WG/N47:2018</i> <sup>[39]</sup>	<b>Corresponding clause(s)/ sub-clause(s) of this document</b>	<b>Qualifying remarks/Notes</b>
	f) 201.11.7, 201.12.1.101, 201.12.1.102, 201.12.1.103, 201.12.1.104	
5.3.2	201.7.9.2.12 aa), 201.11.6.6, 201.11.7	
5.3.3	201.11.7, 201.101.2.2, 201.102.5	
5.3.4	201.11.6.5.101	
5.3.5	201.11.6	
	a) 201.11.6.6	
	b) 201.11.7, 201.101.2.2, 201.102.5	
	c) 201.11.6.6, 201.101.2.2	
5.5.1	201.7.2.4.101, 201.7.9.2.14.101, 201.7.9.3.1.101 a) 3), 201.16.1.101, 201.12.4.101, 201.101, 201.102	
5.5.2	—	
	a) 201.9, 201.12.1, 201.12.4, 206	
	b) 201.12.1, 201.12.4, 206	
	c) 202	
	h) 202	
5.5.3	201.11	
5.5.5	201.7.2.4.101, 201.12.4.101, 201.7.9.2.14.101, 201.7.9.3.1.101 a) 3), 201.16.1.101, 201.101, 201.102	
5.5.6	201.12.101	
5.5.7	201.12.1, 206	
5.6.1	201.15.3.5.101	
5.6.3	201.9.6.2.1.101	
5.6.4	201.101, 201.102	
5.6.5	201.11.1.2.2	
5.7.1	201.13	
5.7.2	201.11.8.101.1	
5.7.3	201.11.8.101.1	
5.7.5	202	
5.7.6	202	
5.7.7	201.8, 201.13	
5.8.1	201.14	
5.8.2	201.14	
5.9	—	
	a) 201.12.1.101, 201.12.1.102, 201.12.1.103, 201.12.1.104	
	c) 201.12.1, 206	
5.10.1	201.7.9.2.1.101, 201.7.9.2.2.101	

<b>Essential principle of IMDRF/GRRP WG/N47:2018</b> <sup>[39]</sup>	<b>Corresponding clause(s)/ sub-clause(s) of this document</b>	<b>Qualifying remarks/Notes</b>
6.1.1	201.11.7	
6.1.2	201.11.7	
6.1.3	201.11.7	
6.4.1	201.12.1, 201.12.1.101, 201.12.1.102, 201.12.1.103, 201.12.1.104	
6.4.2	201.12.4.101, 201.12.4.102, 201.12.4.103, 201.12.4.104, 201.12.4.105, 201.12.4.106, 201.12.4.107, 201.12.4.108, 201.12.4.109, 201.12.4.110	

NOTE 2 When a labelling principle does not appear in Table CC.2, it means that it is not addressed by this document.

**Table CC.2 — Correspondence between this document and the labelling principles**

<b>Labelling principles of IMDRF/GRRP WG/N52:2019</b> <sup>[40]</sup>	<b>Corresponding clause(s)/ sub-clause(s) of this document</b>	<b>Qualifying remarks/Notes</b>
5.1.1	201.7.9.2.1.101, 201.7.9.2.2.101	
5.1.4	201.7.2.101	
5.1.5	201.7	
5.2.1	201.7.2.101	
5.3.5	201.7.9.2.1.101, 201.7.9.2.2.101	
5.3.6	201.7.9.2.1.101, 201.7.9.2.2.101	
5.3.10	201.7.9.2.1.101, 201.7.9.2.2.101	
5.3.11	201.7.9.2.1.101, 201.7.9.2.2.101	
5.3.12	201.12.101	
5.3.13	201.7.9.2.2.101, 201.7.9.2.9.101	
5.3.14	201.7.9.2.8.101	
5.3.18	201.7.9.2.8.101	
5.3.19	201.7.9.2.8.101	
5.3.20	201.7.9.2.8.101, 201.7.9.2.12	
5.3.26	201.7.9.2.12	
5.3.27	201.7.9.2.8.101, 201.7.9.2.14.10, 201.16	

## Annex DD (informative)

### Reference to the *essential principles*

This document has been prepared to support the *essential principles of safety and performance* of a *ventilator*, its *accessories* or parts as medical devices according to ISO 16142-1:2016. This document is intended to be acceptable for conformity assessment purposes.

Conformance with this document provides one means of demonstrating conformance with the specific *essential principles* of Annex B of ISO 16142-1:2016. Other means are possible. Table DD.1 maps the clauses and subclauses of this document with the *essential principles* of ISO 16142-1:2016.

NOTE When an *essential principle* does not appear in Table DD.1, it means that it is not addressed by this document.

**Table DD.1 — Correspondence between this document and the *essential principles***

<i>Essential principle</i> of ISO 16142-1:2016, Annex B	Corresponding clause(s)/sub-clause(s) of this document	Qualifying remarks/Notes
1	All	The part relating to manufacturing is not addressed
a)	206	
b)	206	
2	201.4, 201.4.3.101	The part relating to manufacturing is not addressed
a)	All	
b)	201.4	The part relating to manufacturing is not addressed
c)	201.4, 201.4.3.101, 201.11.8.101, 201.12.4	
d)	201.7	
3	All	The part relating to manufacturing is not addressed
4	All	
5	201.4	
6	201.4	
8.1	—	
a)	201.11.7	
b)	201.11.7	
c)	201.15.3.5.10	
8.2	201.7.9.2.12 aa), 201.11.6.6, 201.11.7	
8.3	201.11.6.6, 201.11.7	
8.4	201.11.7, 201.101.2.2, 201.102.5	
9.1	201.11.6.6	

<b>Essential principle of ISO 16142-1:2016, Annex B</b>	<b>Corresponding clause(s)/sub-clause(s) of this document</b>	<b>Qualifying remarks/Notes</b>
a)	201.11.6.6	
b)	201.11, 201.101.2.2, 201.102.5	
c)	201.11.6.6, 201.101.2.2	
12.1	201.7.2.4.101, 201.7.9.3.1.101 a) 3), 201.7.9.2.14.101, 201.16.1.101, 201.12.4.101, 201.101, 201.102	
12.2	—	
a)	201.9, 201.12.1, 201.12.4, 206	
b)	201.12.1, 201.12.4, 206	
c)	202	
12.4	201.11	
13.1	201.12.1.101, 201.12.1.102, 201.12.1.103, 12.1.104	
13.2	201.12.1	
13.3	201.12.1, 206	
15.1	201.14	
15.2	201.14	
16.1	201.13	
16.2	201.11.8.101.1	
16.3	201.11.8.101.1	
16.5	202	
16.6	202	
16.7	201.8	
17.1	201.9, 201.15.3.5.101	
17.3	201.9.6.2.1.101	
17.4	201.101, 201.102	
17.5	201.101, 201.102	
17.6	201.11.1.2.2	
18.1	201.12.1.101, 201.12.1.102, 201.12.1.103, 201.104	
18.2	201.12.4.101, 201.12.4.102, 201.12.4.103, 201.12.4.104, 201.12.4.105, 201.12.4.106, 201.12.4.107, 201.12.4.108, 201.12.4.109, 201.12.2.110	
19.1	201.7.1.2.101 a), 201.12.1, 206	
19.2	201.7.1.2.101 a), 201.12.1, 206	
21.1	201.7.9.2.1.101, 201.7.9.2.2.101	
21.3	201.7.2.101	
21.4	201.7.2.101	

<i>Essential principle of ISO 16142-1:2016, Annex B</i>	<b>Corresponding clause(s)/sub-clause(s) of this document</b>	<b>Qualifying remarks/Notes</b>
21.7	—	
k)	201.7.9.2.8.101, 201.7.9.2.14.101, 201.16	
l)	201.7.9.2.8.101	
n)	202	
21.9	—	
a)	201.7.9.2.2.101	
b)	202	
d)	201.7.9.2	

## Annex EE (informative)

### Reference to the general safety and performance requirements

This document has been prepared to support the general safety and performance requirements (GSPR) of regulation (EU) 2017/745 <sup>[38]</sup>. This document is intended to be acceptable for conformity assessment purposes.

Conformance with this document provides one means of demonstrating conformance with the specific general safety and performance requirements of regulation (EU) 2017/745 <sup>[38]</sup>. Other means are possible. Table EE.1 maps the clauses and subclauses of this document with the general safety and performance requirements of regulation (EU) 2017/745.

NOTE When a general safety and performance requirement does not appear in Table EE.1, it means that it is not addressed by this document.

**Table EE.1 — Correspondence between this document and the general safety and performance requirements**

General safety and performance requirements of regulation (EU) 2017/745, Annex I <sup>[38]</sup>	Corresponding clause(s)/sub-clause(s) of this document	Qualifying remarks/Notes
1	All	
2	206	
4	201.4, 201.4.3.101	
4 a)	201.4, 201.4.3.101	
4 b)	201.4, 201.4.3.101, 201.11.8.101, 201.12.4	
4 c)	201.7	
5 a)	201.12.1, 206	
5 b)	206	
6	All	
7	201.4	
8	201.4	
10.1 a)	201.11.7	Only the requirements related to toxicity are covered.
10.1 b)	201.11.7	This requirement is covered with respect to the <i>gas pathways</i>
10.1 d)	201.11.6.6	Covered for <i>normal use</i> including <i>cleaning, disinfection</i> and <i>sterilization</i> .
10.1 f)	201.15.3.5.10	
10.1 g)	201.11.6.6 bb)	Covered for <i>normal use</i> including <i>cleaning, disinfection</i> and <i>sterilization</i> .
10.1 h)	201.11.7, 201.12.1.101, 201.12.1.102, 201.12.1.103, 201.12.1.104	Covered for <i>biocompatibility</i> and accuracy of <i>mean airway pressure</i> , <i>FiO<sub>2</sub> concentration</i> and response to an increase in set O <sub>2</sub> concentration

General safety and performance requirements of regulation (EU) 2017/745, Annex I <sup>[38]</sup>	Corresponding clause(s)/sub-clause(s) of this document	Qualifying remarks/Notes
10.2	201.7.9.2.12 aa), 201.11.6.6, 201.11.7	Only the part of GSPR 10.2 relating to design is addressed
10.3	201.11.6.6, 201.11.7	Only the part of GSPR 10.3 relating to design is addressed.
10.4.1	201.11.7, 201.101.2.2, 201.102.5	Only the part of GSPR 10.4 relating to design is addressed.
10.5	201.11.6.5.101	
10.6	201.11.7, 201.102.2.2, 201.102.5	Only the part of GSPR 10.6 relating to design is addressed.
11.1	201.11.6	Only the part of GSPR 11.1 relating to design is addressed.
11.1 b)	201.11.6.6	Only the part of GSPR 11.1 relating to design is addressed.
11.1 c)	201.11.7, 201.101.2.2, 201.102.5	
11.1 d)	201.11.6.6, 201.101.2.2	
11.2	201.11.6.6	
14.1	201.7.2.4.101, 201.7.9.2.14.101, 201.7.9.3.1.101 a) 3), 201.12.4.101, 201.16.1.101, 201.101, 201.102	
14.2 a)	201.9, 201.12.1, 201.12.4, 206	Only the part of GSPR 14.2 a) relating to design is addressed.
14.2 b)	202	Only the part of GSPR 14.2 b) relating to design is addressed.
14.2 f)	202	Only the part of GSPR 14.2 f) relating to design is addressed.
14.3	201.11	Only the part of GSPR 14.3 relating to design is addressed.
14.5	201.7.2.4.101, 201.7.9.2.14.101, 201.12.4.101, 201.7.9.3.1.101 a) 3), 201.16.1.101, 201.101, 201.102	Covered with respect to use with the listed accessories, connecting accessories and operator-detachable components.
14.6	201.12.1, 206	
15.1	201.12.1.101, 201.12.1.102, 201.12.1.103, 201.12.1.104	The part of GSPR 15.1 relating to stability is not addressed.
17.1	201.14	
17.2	201.14	
18.1	201.13	
18.2	201.11.8.101.1	
18.3	201.11.8.101.1	
18.5	202	
18.6	202	
18.7	201.8, 201.13	
18.8	201.12.101	
20.1	201.15.3.5.101	
20.3	201.9.6.2.1.101	Only the part of GSPR 20.3 relating to design is addressed.



General safety and performance requirements of regulation (EU) 2017/745, Annex I <sup>[38]</sup>	Corresponding clause(s)/sub-clause(s) of this document	Qualifying remarks/Notes
20.4	201.101, 201.102	
20.5	201.101, 201.102	Only the part of GSPR 20.5 relating to design is addressed.
20.6	201.11.1.2.2	
21.1	201.12.1, 201.12.1.101, 201.12.1.102, 201.12.1.103, 201.12.1.104	Only the protection of the patient is covered.
21.2	201.12.4.101, 201.12.4.102, 201.12.4.103, 201.12.4.104, 201.12.4.105, 201.12.4.106, 201.12.4.107, 201.12.4.108, 201.12.4.109, 210.12.4.110	Only the first sentence of GSPR 21.2 is covered.
21.3	201.7.2.101 a), 201.12.1, 206	
23.1	201.7.9.2.1.101, 201.7.9.2.2.101	
23.1 a)	201.7.9.2.1.101	
23.1 b)	201.7.2.101	
23.1 g)	201.7.9.2.1.101, 201.7.9.2.2.101	
23.1 h)	201.7.2.101	
23.2 f)	201.11.7	
23.4 e)	201.7.9.2.9.101	
23.4 f)	201.7.9.2.9.101	
23.4 g)	201.7.9.2.2.101, 201.7.9.2.9.101	
23.4 h)	201.12.101	
23.4 k)	201.7.9.2.8.101	
23.4 n)	201.7.9.2.12	
23.4 q)	201.7.9.2.8.101, 201.7.9.2.14.101, 201.16	
23.4 s)	201.7.9.2.2.101	

For devices which are also machinery within the meaning of Article 2(a) of Directive 2006/42/EC <sup>[37]</sup> on Machinery, in accordance with Article 1 Element 12 of regulation (EU) 2017/745 <sup>[38]</sup> the following Table EE.2 details the relevant essential health and safety requirements of Directive 2006/42/EC on Machinery to the extent to which they are more specific than those of regulation (EU) 2017/745 along with the corresponding clauses of this document.

NOTE When a general safety and performance requirement does not appear in Table EE.2, it means that it is not addressed by this document.

**Table EE.2 — Correspondence between this document and relevant essential health and safety requirements from Directive 2006/42/EC <sup>[37]</sup> on machinery**

EHSR of 2006/42/EC <sup>[37]</sup>	Corresponding clause(s)/sub-clause(s) of this document	Qualifying remarks/Notes
1.1.4	201.12.1	
1.2.2	201.12.1, 206	
1.5.4	201.7.2.101 a), 201.7.2.101 b) 2), 201.101.3	

## Annex FF (informative)

### Terminology — alphabetized index of defined terms

NOTE The ISO Online Browsing Platform (OBP)<sup>3</sup> and the IEC Electropedia<sup>4</sup> provide access to many of these terms and definitions.

Term	Source
<i>accessory</i>	IEC 60601-1:2005, 3.3
<i>accompanying document</i>	IEC 60601-1:2005, 3.4
<i>accompanying information</i>	201.3.201
<i>acknowledged</i>	IEC 60601-1-8:2006+AMD1:2012, 3.37
<i>airway device</i>	201.3.202
<i>airway pressure (<math>P_{aw}</math>)</i>	201.3.203
<i>alarm condition</i>	IEC 60601-1-8:2006+AMD1:2012, 3.1
<i>alarm condition delay</i>	IEC 60601-1-8:2006, 3.2
<i>alarm fatigue</i>	IEC 60601-1-8:2006+AMD1:2012+AMD2:2020, 3.38
<i>alarm limit</i>	IEC 60601-1-8:2006, 3.3
<i>alarm off</i>	IEC 60601-1-8:2006, 3.4
<i>alarm paused</i>	IEC 60601-1-8:2006, 3.5
<i>alarm settings</i>	IEC 60601-1-8:2006, 3.8
<i>alarm signal</i>	IEC 60601-1-8:2006, 3.9
<i>alarm system</i>	IEC 60601-1-8:2006, 3.11
<i>applied part</i>	IEC 60601-1:2005, 3.8
<i>artificial ventilation</i>	201.3.204
<i>audio off</i>	IEC 60601-1-8:2006, 3.12
<i>audio paused</i>	IEC 60601-1-8:2006, 3.13
<i>basic safety</i>	IEC 60601-1:2005, 3.10
<i>bi-level positive airway pressure</i>	201.3.205
<i>bias flow</i>	201.3.206
<i>biocompatibility</i>	201.3.207
<i>bi-level PAP</i>	201.3.205
<i>breathing system filter</i>	201.3.208
<i>BSF</i>	201.3.208
<i>BTPS</i>	201.3.209

<sup>3</sup> Available at: <https://www.iso.org/obp>

<sup>4</sup> Available at <http://www.electropedia.org/>

<b>Term</b>	<b>Source</b>
<i>cleaning</i>	201.3.210
<i>clearly legible</i>	IEC 60601-1:2005+AMD1:2012, 3.15
<i>continuous flow</i>	201.3.211
<i>continuous operation</i>	IEC 60601-1:2005, 3.18
<i>continuous positive airway pressure</i>	201.3.212
<i>CPAP</i>	201.3.212
<i>disinfection</i>	201.3.213
<i>distributed alarm system</i>	IEC 60601-1-8:2006, 3.17
<i>emergency intake port</i>	201.3.214
<i>emergency medical services environment</i>	201.3.215
<i>EMS ventilator</i>	201.3.216
<i>enclosure</i>	IEC 60601-1:2005, 3.26
<i>essential performance</i>	IEC 60601-1:2005+AMD1:2012, 3.27
<i>essential principles</i>	201.3.217
<i>essential principles of safety and performance</i>	201.3.217
<i>exhaust port</i>	201.3.218
<i>expected service life</i>	IEC 60601-1:2005+AMD1:2012, 3.28
<i>expiratory phase</i>	201.3.219
<i>expired minute volume</i>	201.3.220
<i>fail-safe ventilation</i>	201.3.221
<i>false positive alarm condition</i>	IEC 60601-1-8:2006, 3.21
<i>flow-direction-sensitive component</i>	201.3.222
<i>functional connection</i>	IEC 60601-1:2005, 3.33
<i>gas intake port</i>	201.3.223
<i>gas output port</i>	201.3.224
<i>gas pathway</i>	201.3.225
<i>gas return port</i>	201.3.226
<i>harm</i>	IEC 60601-1:2005+AMD1:2012+AMD2:2020, 3.38
<i>hazard</i>	IEC 60601-1:2005+AMD1:2012+AMD2:2020, 3.39
<i>hazardous situation</i>	IEC 60601-1:2005+AMD1:2012+AMD2:2020, 3.40
<i>healthcare professional</i>	201.3.227
<i>HFV</i>	201.3.228
<i>HFV breathing system</i>	201.3.229
<i>HFV frequency</i>	201.3.230
<i>HFV inflation</i>	201.3.231
<i>HFV volume</i>	201.3.232
<i>high priority</i>	IEC 60601-1-8:2006, 3.22
<i>high-frequency ventilator</i>	201.3.228
<i>high-pressure inlet</i>	201.3.233

Term	Source
<i>home healthcare environment</i>	201.3.234
<i>humidifier</i>	201.3.235
<i>I:E ratio</i>	201.3.236
<i>immunity</i>	IEC 60601-1-2:2014, 3.8
<i>inflation</i>	201.3.237
<i>inflation-type</i>	201.3.238
<i>information signal</i>	IEC 60601-1-8:2006, 3.23
<i>information for safety</i>	201.3.239
<i>information supplied by the manufacturer</i>	201.3.240
<i>inspiratory time (<math>t_I</math>)</i>	201.3.241
<i>inspiratory volume (<math>V_I</math>)</i>	201.3.242
<i>instructions for use</i>	201.3.243
<i>intended use</i>	IEC 60601-1:2005+AMD1:2012+AMD2:2020, 3.44
<i>intelligent alarm system</i>	IEC 60601-1-8:2006, 3.24
<i>internal electrical power source</i>	IEC 60601-1:2005, 3.45
<i>latching alarm signal</i>	IEC 60601-1-8:2006, 3.26
<i>lay</i>	201.3.244
<i>low priority</i>	IEC 60601-1-8:2006, 3.27
<i>lung</i>	201.3.245
<i>manufacturer</i>	IEC 60601-1:2005+AMD1:2012+AMD2:2020, 3.55
<i>marked</i>	201.3.246
<i>marking</i>	201.3.246
<i>mask</i>	201.3.247
<i>maximum limited pressure (<math>P_{Lim,max}</math>)</i>	201.3.248
<i>ME equipment</i>	IEC 60601-1:2005, 3.63
<i>ME system</i>	IEC 60601-1:2005, 3.64
<i>mean airway pressure</i>	201.3.249
<i>mechanical hazard</i>	IEC 60601-1:2005, 3.61
<i>medical electrical equipment</i>	IEC 60601-1:2005, 3.63
<i>medical electrical system</i>	IEC 60601-1:2005, 3.64
<i>medical gas pipeline system</i>	201.3.250
<i>medium priority</i>	IEC 60601-1-8:2006, 3.28
<i>minimum limited pressure (<math>P_{Lim,min}</math>)</i>	201.3.251
<i>model or type reference</i>	IEC 60601-1:2005, 3.66
<i>monitoring equipment</i>	201.3.252
<i>nominal &lt;value&gt;</i>	IEC 60601-1:2005, 3.69
<i>normal condition</i>	IEC 60601-1:2005, 3.70
<i>normal use</i>	IEC 60601-1:2005, 3.71

<b>Term</b>	<b>Source</b>
<i>operator</i>	IEC 60601-1:2005, 3.73
<i>operator-equipment interface</i>	IEC 60601-1-6:2010, 3.1
<i>operator's position</i>	IEC 60601-1-8:2006, 3.30
<i>patient</i>	IEC 60601-1:2005+AMD1:2012, 3.76
<i>patient-connection port</i>	201.3.253
<i>patient variable</i>	201.3.254
<i>PEMS</i>	IEC 60601-1:2005, 3.90
<i>PESS</i>	IEC 60601-1:2005, 3.91
<i>physiologic closed-loop control system</i>	201.3.255
<i>pressure amplitude</i>	201.3.256
<i>pressure-control</i>	201.3.257
<i>primary operating function</i>	IEC 60601-1:2005+AMD1:2012+AMD2:2020, 3.146
<i>procedure</i>	IEC 60601-1:2005+AMD1:2012+AMD2:2020, 3.88
<i>process</i>	IEC 60601-1:2005+AMD1:2012+AMD2:2020, 3.89
<i>processing</i>	201.3.258
<i>professional healthcare facility</i>	201.3.259
<i>programmable electrical medical systems</i>	IEC 60601-1:2005, 3.90
<i>programmable electronic subsystem</i>	IEC 60601-1:2005, 3.91
<i>protection device</i>	201.3.260
<i>rated &lt;value&gt;</i>	IEC 60601-1:2005, 3.97
<i>recruitment manoeuvre</i>	201.3.261
<i>residual risk</i>	IEC 60601-1:2005+AMD1:2012+AMD2:2020, 3.100
<i>responsible organization</i>	IEC 60601-1:2005, 3.101
<i>risk</i>	IEC 60601-1:2005+AMD1:2012+AMD2:2020, 3.102
<i>risk assessment</i>	IEC 60601-1:2005+AMD1:2012+AMD2:2020, 3.105
<i>risk control</i>	IEC 60601-1:2005+AMD1:2012+AMD2:2020, 3.105
<i>risk management</i>	IEC 60601-1:2005+AMD1:2012+AMD2:2020, 3.107
<i>risk management file</i>	IEC 60601-1:2005+AMD1:2012+AMD2:2020, 3.108
<i>safety sign</i>	201.3.262
<i>service personnel</i>	IEC 60601-1:2005, 3.113
<i>set rate</i>	201.3.263
<i>single fault condition</i>	IEC 60601-1:2005+AMD1:2012, 3.116
<i>single fault safe</i>	IEC 60601-1:2005, 3.117
<i>single use</i>	201.3.264
<i>software item</i>	201.3.265
<i>spontaneous breath rate</i>	201.3.266
<i>standard temperature pressure, dry</i>	201.3.267
<i>stationary</i>	IEC 60601-1:2005+AMD1:2012, 3.118
<i>sterile</i>	201.3.268

<b>Term</b>	<b>Source</b>
<i>sterilization</i>	201.3.269
<i>STPD</i>	201.3.267
<i>suction catheter</i>	201.3.270
<i>supply mains</i>	IEC 60601-1:2005, 3.120
<i>symbol</i>	201.3.271
<i>technical alarm condition</i>	IEC 60601-1-8:2006, 3.36
<i>technical description</i>	201.3.272
<i>tool</i>	IEC 60601-1:2005, 3.127
<i>transit-operable</i>	201.3.273
<i>type test</i>	IEC 60601-1:2005, 3.135
<i>usability</i>	IEC 60601-1:2005+AMD1:2012+AMD2:2020, 3.136
<i>usability engineering</i>	IEC 60601-1:2005+AMD1:2012+AMD2:2020, 3.137
<i>usability engineering file</i>	IEC 60601-1:2005+AMD1:2012+AMD2:2020, 3.147
<i>use error</i>	201.3.274
<i>validated</i>	201.3.275
<i>VBS</i>	201.3.276
<i>ventilation</i>	201.3.277
<i>ventilator</i>	201.3.278
<i>ventilator breathing system</i>	201.3.276
<i>ventilator operational mode</i>	201.3.279
<i>ventilator-dependent</i>	201.3.280
<i>verification (verified)</i>	IEC 60601-1:2005+AMD1:2012+AMD2:2020, 3.138
<i>volume-control</i>	201.3.281

## Bibliography

- [1] ISO 594-1:1986, *Conical fittings with a 6 % (Luer) taper for syringes, needles and certain other medical equipment — Part 1: General requirements*
- [2] ISO 594-2:1998, *Conical fittings with 6 % (Luer) taper for syringes, needles and certain other medical equipment — Part 2: Lock fittings*
- [3] ISO 639-1:2002, *Codes for the representation of names of languages — Part 1: Alpha-2 code*
- [4] ISO 4135, *Anaesthetic and respiratory equipment — Vocabulary and semantics*
- [5] ISO 7396-2:2007, *Medical gas pipeline systems — Part 2: Anaesthetic gas scavenging disposal systems*
- [6] ISO 8601-1:2019, *Date and time — Representations for information interchange — Part 1: Basic rules*
- [7] ISO 8836:2014, *Suction catheters for use in the respiratory tract*
- [8] ISO 9000:2015, *Quality management systems — Fundamentals and vocabulary*
- [9] ISO 10079-1:2015+AMD1:2018, *Medical suction equipment — Part 1: Electrically powered suction equipment*
- [10] ISO 10079-3:2014, *Medical suction equipment — Part 3: Suction equipment powered from a vacuum or positive pressure gas source*
- [11] ISO 10524-1:2018, *Pressure regulators for use with medical gases — Part 1: Pressure regulators and pressure regulators with flow-metering devices*
- [12] ISO 10524-1:2018, *Pressure regulators for use with medical gases — Part 1: Pressure regulators and pressure regulators with flow-metering devices*
- [13] ISO 10651-3:1997, *Lung ventilators for medical use — Part 3: Particular requirements for emergency and transport ventilators*
- [14] ISO 10651-4:2002, *Lung ventilators — Part 4: Particular requirements for operator-powered resuscitators*
- [15] ISO 10651-6:2004, *Lung ventilators for medical use — Particular requirements for basic safety and essential performance — Part 6: Home-care ventilatory support devices*
- [16] ISO/IEEE 11073-10101, *Health informatics — Device interoperability — Part 10101: Point-of-care medical device communication — Nomenclature*
- [17] ISO/IEEE 11073-20701:2020, *Health informatics — Device interoperability — Part 20701: Point-of-care medical device communication — Service oriented medical device exchange architecture and protocol binding*
- [18] ISO 14159, *Safety of machinery — Hygiene requirements for the design of machinery*
- [19] ISO 15001:2010, *Anaesthetic and respiratory equipment — Compatibility with oxygen*
- [20] ISO 19223:2019, *Lung ventilators and related equipment — Vocabulary and semantics*

- [21] ISO 80369-2:—<sup>5</sup>, *Small-bore connectors for liquids and gases in healthcare applications — Part 2: Connectors for breathing systems and driving gases applications*
- [22] ISO 80369-7:2020, *Small-bore connectors for liquids and gases in healthcare applications - Part 7: Connectors for intravascular or hypodermic applications*
- [23] ISO 80601-2-12:2020, *Medical electrical equipment — Part 2-12: Particular requirements for basic safety and essential performance of critical care ventilators*
- [24] ISO 80601-2-13:2011+AMD1:2015+AMD2:2018, *Medical electrical equipment — Part 2-13: Particular requirements for basic safety and essential performance of an anaesthetic workstation*
- [25] ISO 80601-2-70:2015, *Medical electrical equipment — Part 2-70: Particular requirements for basic safety and essential performance of sleep apnoea breathing therapy equipment*
- [26] ISO 80601-2-72:2015, *Medical electrical equipment — Part 2-72: Particular requirements for basic safety and essential performance of home healthcare environment ventilators for ventilator-dependent patients*
- [27] ISO 80601-2-79:2018, *Medical electrical equipment — Part 2-79: Particular requirements for basic safety and essential performance of home healthcare environment ventilatory support equipment for respiratory impairment*
- [28] ISO 80601-2-80:2018, *Medical electrical equipment — Part 2-80: Particular requirements for basic safety and essential performance of home healthcare environment ventilatory support equipment for respiratory insufficiency*
- [29] IEC 60601-1-3:2008, *Medical electrical equipment — Part 1-3: General requirements for basic safety and essential performance — Collateral Standard: Radiation protection in diagnostic X-ray equipment*
- [30] IEC 60601-1-9:2007+AMD1:2013+AMD2:2020, *Medical electrical equipment — Part 1-9: General requirements for basic safety and essential performance — Collateral Standard: Requirements for environmentally conscious design*
- [31] IEC 60601-1-12:2014+AMD1:2020, *Medical electrical equipment — Part 1-12: General requirements for basic safety and essential performance — Collateral Standard: Requirements for medical electrical equipment and medical electrical systems intended for use in the emergency medical services environment*
- [32] IEC 60721-3-7, *Classification of environmental conditions — Part 3-7: Classification of groups of environmental parameters and their severities — Portable and non-stationary use*
- [33] IEC/TR 60721-4-7:2001+AMD1:2013, *Classification of environmental conditions — Part 4-7: Guidance for the correlation and transformation of environmental condition classes of IEC 60721-3 to the environmental tests of IEC 60068 — Portable and non-stationary use*
- [34] IEC/TR 60878:2015, *Graphical symbols for electrical equipment in medical practice*
- [35] IEC 80001-2-5:2014, *Application of risk management for IT-networks incorporating medical devices — Part 2-5: Application guidance — Guidance for distributed alarm systems*

<sup>5</sup> Under preparation. Stage at the time of publication: ISO DIS 80369-2:2020.



- [36] AAMI 2700-1:2019, *Medical Devices and Medical Systems — Essential safety requirements for equipment comprising the patient-centric integrated clinical environment (ICE) — Part 1: General requirements and conceptual model*
- [37] (EC) 2006/42, (2006) Directive 2006/42/EC of the European Parliament and of the Council of 17 May 2006 on machinery. OJ L 15717, Official Journal of the European Union, pp. 24-86
- [38] (EU) 2017/745, (2017) Regulation (EU) 2017/745 of the European Parliament and of the Council of 5 April 2017 on medical devices. OJ L 117, Official Journal of the European Union, pp. 1-175
- [39] IMDRF/GRRP WG/N47:2018<sup>6</sup>, *Essential Principles of Safety and Performance of Medical Devices and IVD Medical Devices*
- [40] IMDRF/GRRP WG/N52:2019<sup>7</sup>, *Labeling Principles for Medical Devices and IVD Medical Devices*
- [41] US Code of Federal Regulation, 45 CFR Part 170, *Health Information Technology: Initial Set of Standards, Implementation Specifications, and Certification Criteria for Electronic Health Record Technology; Interim Final Rule*, US Federal Register, **75**(8), 2010-01-13, pp.2014-2047
- [42] ALLNUTT, M.F. (1987) Human factors in accidents. *Br. J. Anaesth.* **59**, pp.856-864
- [43] BARRETT, K. et al. (2012) *Ganong's Review of Medical Physiology*, 24th ed, McGraw Hill, p. 619.
- [44] BRIDI AC, LOURO TQ, DA SILVA RCL. (2014) Clinical alarms in intensive care: implications of alarm fatigue for the safety of patients. *Revista Latino-Americana de Enfermagem.* **22**(6):1034-1040. doi:10.1590/0104-1169.3488.2513
- [45] BURTON, G.W. and FOX, D.E.R. (1972) An airway resistance for use in an artificial lung. *Br J Anaesth*, **44**, pp. 1253-1262
- [46] CHAN, V. GREENOUGH, A. (1993) A Determinants of oxygenation during high frequency oscillation. *Eur J Pediatr*, **152**(4), pp. 350-353
- [47] EL MASRY, A., et al, (2005) The impact of closed endotracheal suctioning systems on mechanical ventilator performance, *Respir Care*, **50**(3), pp. 345-53
- [48] EVANS RS, JOHNSON KV, FLINT VB, et al. (2005) Unit-wide Notification of Ventilator Disconnections. AMIA Annual Symposium Proceedings. p.951
- [49] FREDBERG J.J., GLASS G.M., BOYNTON B.R., Frantz I.D., (1987) Factors influencing mechanical performance of neonatal high frequency ventilators. *J Appl Physiology* **62**(6), pp. 2485-2490
- [50] FROESE, A.B., (2006) High-Frequency Ventilation. In: *Principles and Practice of Mechanical Ventilation*, Second edition; (ed. Tobin, M.J., MD), McGraw-Hill, New York. pp. 473-492. ISBN 0873894286

<sup>6</sup> Available at <http://www.imdrf.org/documents/documents.asp>.

<sup>7</sup> Available at <http://www.imdrf.org/documents/documents.asp>.

- [51] FUKUNAGA, T, et al, Prolonged high intermittent positive-pressure ventilation induces airway remodelling and reactivity in young rats, *Am.J Physiol.*, **275**(3 Pt 1), 1998, pp. L567-L573
- [52] GALLAGHER S., VERCRUYSSSEN M., DENO N. (1985) Hot air breathing: effects of elevated wet bulb temperatures on tissue temperatures of the mouth. *Am. Ind. Hyg. Assoc. J.* **46**(6) pp. 332-335
- [53] HEDLEY-WHYTE J., PONTOPPIDAN H., MORRIS M.J., (1966) The response of patients with respiratory failure and cardiopulmonary disease to different levels of constant volume ventilation, *J Clin Invest*, **45**(10), pp. 1543-1554
- [54] HILL, D.W. and MOORE, V. (1965) The action of adiabatic effects on the compliance of an artificial thorax. *Br J Anaesth*, **37**, pp. 19-22
- [55] KILLICK E. (1931) *Physiological response to breathing hot air*. Dept of Physiology, University of Leeds
- [56] LAGEVIN, P.B., et al, (1999) Synchronization of radiograph film exposure with the inspiratory pause effect on the appearance of bedside chest radiographs in mechanically ventilated patients. *Am J of Resp Crit Care Med*, **160**(6), pp. 2067-2071
- [57] LOWERY, WC. (2010) Ventilator - disconnect and death: a case study and a safety device. *Respir Care*; **55**(6), pp.774-776
- [58] MECKLENBURGH, J.S. (1988) Construction of linear resistance units for a model lung. *Med Bio Elect Comp*, **26**, pp. 552-554
- [59] MORITZ A.R., HENRIQUES F.C. JR. (1947) Studies of thermal injury II. The relative importance of time and surface temperature in the causation of cutaneous burns. *Am. J. Pathol.* **23**(5) pp. 695-720
- [60] MOTOYAMA, E.K. et al, (1987) Early onset of airway reactivity in premature infants with bronchopulmonary dysplasia, *Am Rev Respir Dis*, **136**(1), pp. 50-57
- [61] MUSHIN, W.W., RENDELL-BAKER, L., THOMPSON, P.W. and MAPLESON, W.W. (1980) *Automatic Ventilation of the Lungs* (3rd edition), pp. 182-183
- [62] Report of the Naval Medical Research and Development Command, (1980) *Physiological Design Goals for Thermal Protection for Divers*, Conference report of 5 September 1980
- [63] RODRIGUEZ-MOLINERO, A. et al, (2013) Normal respiratory rate and peripheral blood oxygen saturation in the elderly population. *J Am Geriatr Soc Dec*, **61**(12), pp.2238-2240.
- [64] STENQVIST O., et al, (2001) Warning! Suctioning. A lung model evaluation of closed suctioning systems, *Acta Anaesthesiol Scand*, **45**, pp. 167-172
- [65] The Acute Respiratory Distress Syndrome Network, (2000) *Ventilation with lower tidal volumes as compared with traditional tidal volumes for acute lung injury and the acute respiratory distress syndrome*. *N Engl J Med.* **342**(18), pp.1301-1308

**NATIONAL ANNEX A**

*([National Foreword](#))*

**A-1 BIS Certification Marking**

The product(s) conforming to the requirements of this standard may be certified as per the conformity assessment schemes under the provisions of the *Bureau of Indian Standards Act, 2016* and the Rules and Regulations framed thereunder, and the product(s) may be marked with the Standard Mark.





## Bureau of Indian Standards

BIS is a statutory institution established under the *Bureau of Indian Standards Act, 2016* to promote harmonious development of the activities of standardization, marking and quality certification of goods and attending to connected matters in the country.

### Copyright

BIS has the copyright of all its publications. No part of these publications may be reproduced in any form without the prior permission in writing of BIS. This does not preclude the free use, in the course of implementing the standard, of necessary details, such as symbols and sizes, type or grade designations. Enquiries relating to copyright be addressed to the Head (Publication & Sales), BIS.

### Review of Indian Standards

Amendments are issued to standards as the need arises on the basis of comments. Standards are also reviewed periodically; a standard along with amendments is reaffirmed when such review indicates that no changes are needed; if the review indicates that changes are needed, it is taken up for revision. Users of Indian Standards should ascertain that they are in possession of the latest amendments or edition by referring to the website-[www.bis.gov.in](http://www.bis.gov.in) or [www.standards.bis.in](http://www.standards.bis.in).

This Indian Standard has been developed from Doc No.: MHD 11 (25230).

### Amendments Issued Since Publication

Amend No.	Date of Issue	Text Affected

## BUREAU OF INDIAN STANDARDS

### Headquarters:

Manak Bhavan, 9 Bahadur Shah Zafar Marg, New Delhi 110002

Telephones: 2323 0131, 2323 3375, 2323 9402

Website: [www.bis.gov.in](http://www.bis.gov.in)

### Regional Offices:

Central : 601/A, Konnectus Tower -1, 6<sup>th</sup> Floor,  
DMRC Building, Bhavbhuti Marg, New  
Delhi 110002

Telephones

{ 2323 7617

Eastern : 8<sup>th</sup> Floor, Plot No 7/7 & 7/8, CP Block, Sector V,  
Salt Lake, Kolkata, West Bengal 700091

{ 2367 0012  
2320 9474

Northern : Plot No. 4-A, Sector 27-B, Madhya Marg,  
Chandigarh 160019

{ 265 9930

Southern : C.I.T. Campus, IV Cross Road, Taramani, Chennai 600113

{ 2254 1442  
2254 1216

Western : Manakalya, 4<sup>th</sup> Floor, NTH Complex (W Sector), F-10, MIDC, Andheri  
(East), Mumbai 400093

{ 283 25838

**Branches :** AHMEDABAD, BENGALURU, BHOPAL, BHUBANESHWAR, CHANDIGARH, CHENNAI, COIMBATORE, DEHRADUN, DELHI, FARIDABAD, GHAZIABAD, GUWAHATI, HARYNA, HUBLI, HYDERABAD, JAIPUR, JAMMU & KASHMIR, JAMSHEDPUR, KOCHI, KOLKATA, LUCKNOW, MADURAI, MUMBAI, NAGPUR, NOIDA, PARWANOO, PATNA, PUNE, RAIPUR, RAJKOT, SURAT, VIJAYAWADA.