

पुनःश्वसन को रोकने वाले वाल्व —
विशिष्टि

भाग 2 अम्बु-हेस्से प्रतिरूप

(पहला पुनरीक्षण)

Valve, Non-Rebreathing —
Specification

Part 2 Ambu-Hesse's Pattern

(First Revision)

ICS 11.040.10

© BIS 2024



भारतीय मानक ब्यूरो
BUREAU OF INDIAN STANDARDS
मानक भवन, 9 बहादुर शाह ज़फर मार्ग, नई दिल्ली - 110002
MANAK BHAVAN, 9 BAHADUR SHAH ZAFAR MARG
NEW DELHI - 110002

www.bis.gov.in www.standardsbis.in

FOREWORD

This Indian Standard (Part 2) (First Revision) was adopted by the Bureau of Indian Standards, after the draft was finalized by the Anaesthetic, Resuscitation, and Allied Equipment Sectional Committee and approved by the Medical Equipment and Hospital Planning Division Council.

This standard was first published in 1976 as Specification for valve, non-rebreathing: Part 2 Ambu-hesse's pattern.

This revision has been taken up to align with latest practice.

The composition of the Committee responsible for formulation of this standard is given in [Annex A](#).

For the purpose of deciding whether a particular requirement of this standard is complied with the final value, observed or calculated, expressing the result of a test or analysis shall be rounded off in accordance with IS 2 : 2022 'Rules for rounding off numerical values (*second revision*)'. The number of significant places retained in the rounded off value should be same as that of the specified value in this standard.

*Indian Standard***VALVE, NON-REBREATHING — SPECIFICATION****PART 2 AMBU-HESSE'S PATTERN***(First Revision)***1 SCOPE**

This Indian standard (Part 2) specifies dimensional and other requirements for Ambu-Hesse's pattern valve used for preventing rebreathing during ventilation of lungs and for equipment for resuscitation

2 REFERENCES

The standard given below contain provisions which, through reference in this text, constitute provisions of this standard. At the time of publication, the editions indicated was valid. All standards are subject to revision, and parties to agreements based on this standard are encouraged to investigate the possibility of applying the most recent edition of this standards:

<i>IS No.</i>	<i>Title</i>
IS/ISO 5356-1 : 2015	Anaesthetic and respiratory equipment — Conical connectors: Part 1 Cones and sockets (<i>first revision</i>)

3 MATERIALS

3.1 The plastics parts shall be sturdy, non-breakable, clean, transparent and free from scratches. They shall be resistant to anaesthetic vapours and gases. They shall withstand the normal steam or chemical sterilization.

3.2 The rubber parts shall be made of good quality natural, antistatic rubber. The rubber shall be resistant to anaesthetic vapours and gases. It shall withstand ageing in an air-oven for 168 hours at 70 °C ± 1 °C without showing appreciable stiffening, softening, cracking or other change in condition. It shall have a minimum tensile strength of 10 MN/m² before and after ageing and a minimum elongation at break of 500 percent before ageing and 400 percent after ageing.

4 SHAPE AND DIMENSIONS

4.1 The shape and dimensions shall be as shown in [Fig. 1](#).

4.2 The dead space (space between the seat of the valve and the patient connector) shall not be more than 17 mm.

4.3 A deviation of ± 2.5 percent shall be allowed on all dimensions.

5 WORKMANSHIP AND FINISH

5.1 The valve shall be designed to prevent rebreathing by ensuring unidirectional flow of all expired gases.

5.2 The valve shall not stick at any stage.

5.3 All the surfaces of the valve shall be smooth and free from pinholes, wrinkles, creases, embedded foreign matter and other defects.

5.4 The inlet and outlet to patient end connections shall be suitable for conical fittings of adult and paediatric sizes conforming to IS/ISO 5356-1.

6 TESTS

6.1 The valve shall be tested for inspiration and expiration pressures. The resistance to flow at 25 litre/min shall not be more than 78 N/m² (approximately 0.8 cm of water) during inspiration and 98 N/m² (approximately 1.0 cm of water) during expiration.

6.2 The functioning of the valve shall remain unimpaired when the valve is operated at a frequency of 40 respirations per minute.

6.3 Non-return Action

6.3.1 The closing of the valve for inspiratory action shall not require a flow of air more than 35 litre/min from the inlet side.

6.3.2 The leakage through the valve, when the valve is closed in either direction under a gas pressure of 1.96 kN/m² (approximately 20 cm of water), shall not be more than 400 ml/min.

7 MARKING AND PACKING

7.1 The valve shall be marked with the manufacturer's name, initials or recognized trademark; and an arrow mark on the body to indicate the direction of flow of gas.

7.2 The packing shall be as agreed to between the purchaser and the manufacturer

7.3 BIS Certification Marking

The product(s) conforming to the requirements of this standard may be certified as per the conformity assessment schemes under the provisions of the *Bureau of Indian Standards Act, 2016* and the Rules and Regulations framed thereunder, and the product(s) may be marked with the Standard Mark.

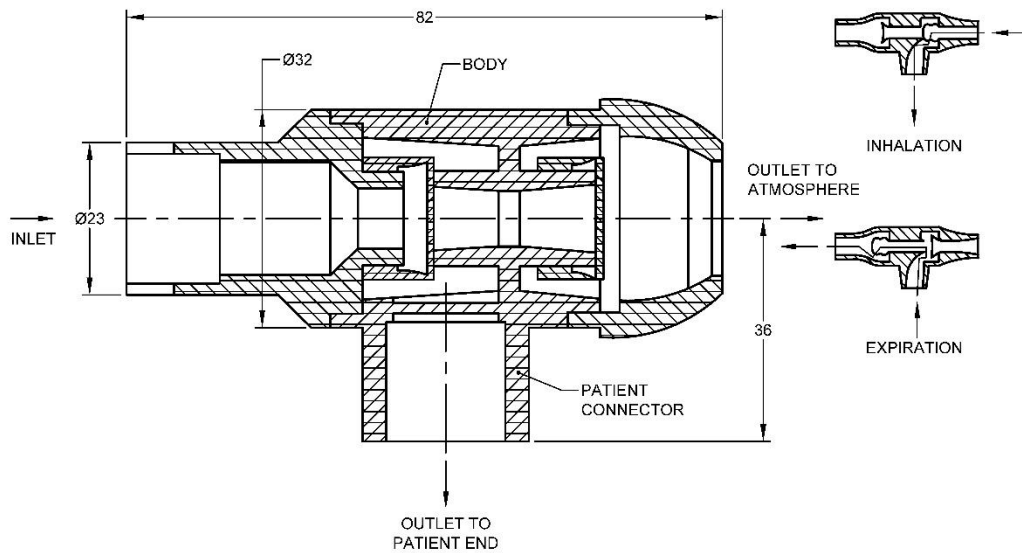

All dimensions in millimetres.

FIG. 1 VALVE, AMBU-HESSE'S PATTERN

All dimensions in millimeters.

FIG. 1 VALVE, AMBU-HESSE'S PATTERN

ANNEX A

(Foreword)

COMMITTEE COMPOSITION

Anaesthetic, Resuscitation and Allied Equipment Sectional Committee, MHD 11

<i>Organization</i>	<i>Representative(s)</i>
In Personal Capacity [<i>Postgraduate Institute of Medical Education and Research (PGIMER), Chandigarh</i>]	DR G. D. PURI (<i>Chairperson</i>)
All India Institute of Medical Sciences, New Delhi	DR LOKESH KASHYAP DR GANGA PRASAD (<i>Alternate</i>)
Allied Medical Services Private Limited, New Delhi	SHRI AKHIL KOHLI
Association of Indian Medical Device Industry, New Delhi	SHRI C. S. PRASAD
Becton Dickinson India Private Limited, Gurugram	SHRI SUDHAKAR MAIRPADY MS NITILESH KUMARII (<i>Alternate</i>)
Central Drugs Standard Control Organization, New Delhi	SHRI ASEEM SAHU SHRI AJAI BASIL (<i>Alternate I</i>) SHRI GULHANE AKSHAY DINKAR (<i>Alternate II</i>)
Draeger India Pvt Ltd, Mumbai	MS JHANKANA GYANI SHRI PRASHANT A. PUROHIT (<i>Alternate I</i>) SHRI ROOPESH VEETIL (<i>Alternate II</i>) SHRI VIJAY SHARMA (<i>Alternate III</i>)
Employees State Insurance Corporation (ESIC), New Delhi	DR MADHU GUPTA
Indian Society of Anaesthesiologists, Kolkata	DR RAKESH GARG DR RAJIV GUPTA (<i>Alternate I</i>) DR AMIT KUMAR (<i>Alternate II</i>)
Kalam Institute of Health Technology, Vishakhapatnam	MS ANKITHA S. SHRI PRAMOD (<i>Alternate I</i>) SHRI SRIPADA SHANKARACHARYA (<i>Alternate II</i>)
Mandev Tubes Private Limited, Mumbai	SHRI ADITYA MUNOT SHRI SANJIV KUMAR GUPTA (<i>Alternate I</i>) SHRI SURENDRA KAMALAKAR PARAB (<i>Alternate II</i>)
Medtronic India Private Limited, Gurugram	SHRI AMIT KUMAR SHRI GURPREET SINGH (<i>Alternate</i>)
Philips India Limited, Gurugram	SHRI A. V. A. RAJENDRA PRASAD MS RADHIKA DEVI (<i>Alternate</i>)
Post Graduate Institute of Medical Education and Research, Chandigarh	DR L. N. YADDANAPUDI DR SANDHYA YADDANAPUDI (<i>Alternate I</i>) DR AAKRITI GUPTA (<i>Alternate II</i>)
Shriram Institute for Industrial Research, Delhi	DR BINU BHAT DR PRIYANKA SHARMA (<i>Alternate</i>)
Sir Ganga Ram Hospital, New Delhi	DR BIMLA SHARMA DR MANISH GUPTA (<i>Alternate</i>)

IS 8254 (Part 2) : 2024

<i>Organization</i>	<i>Representative(s)</i>
Vardhman Mahavir Medical College and Safdarjung Hospital, New Delhi	DR ABHISHEK VERMA
Wipro G.E. Healthcare Private Limited, New Delhi	SHRI DORAI SUBRAMANIAM SHRI NANDHAKUMAR A. (<i>Alternate</i>)
BIS Directorate General	SHRI A. R. UNNIKRISHNAN SCIENTIST, 'G' AND HEAD (MEDICAL EQUIPMENT AND HOSPITAL PLANNING) [REPRESENTING DIRECTOR GENERAL (<i>Ex-officio</i>)]

Member Secretary
SHRI SATYAM RATHORE
SCIENTIST 'B'/ASSISTANT DIRECTOR
(MEDICAL EQUIPMENT AND HOSPITAL PLANNING), BIS

Bureau of Indian Standards

BIS is a statutory institution established under the *Bureau of Indian Standards Act, 2016* to promote harmonious development of the activities of standardization, marking and quality certification of goods and attending to connected matters in the country.

Copyright

BIS has the copyright of all its publications. No part of these publications may be reproduced in any form without the prior permission in writing of BIS. This does not preclude the free use, in the course of implementing the standard, of necessary details, such as symbols and sizes, type or grade designations. Enquiries relating to copyright be addressed to the Head (Publication & Sales), BIS.

Review of Indian Standards

Amendments are issued to standards as the need arises on the basis of comments. Standards are also reviewed periodically; a standard along with amendments is reaffirmed when such review indicates that no changes are needed; if the review indicates that changes are needed, it is taken up for revision. Users of Indian Standards should ascertain that they are in possession of the latest amendments or edition by referring to the website-www.bis.gov.in or www.standardsbis.in.

This Indian Standard has been developed from Doc No.: MHD 11 (18975).

Amendments Issued Since Publication

Amend No.	Date of Issue	Text Affected

BUREAU OF INDIAN STANDARDS

Headquarters:

Manak Bhavan, 9 Bahadur Shah Zafar Marg, New Delhi 110002

Telephones: 2323 0131, 2323 3375, 2323 9402

Website: www.bis.gov.in

Regional Offices:

Central : 601/A, Konnectus Tower -1, 6th Floor,
DMRC Building, Bhavbhuti Marg, New
Delhi 110002

Telephones

{ 2323 7617

Eastern : 8th Floor, Plot No 7/7 & 7/8, CP Block, Sector V,
Salt Lake, Kolkata, West Bengal 700091

{ 2367 0012
2320 9474

Northern : Plot No. 4-A, Sector 27-B, Madhya Marg,
Chandigarh 160019

{ 265 9930

Southern : C.I.T. Campus, IV Cross Road, Taramani, Chennai 600113

{ 2254 1442
2254 1216

Western : Manakalya, 4th Floor, NTH Complex (W Sector), F-10, MIDC, Andheri
(East), Mumbai 400093

{ 283 25838

Branches : AHMEDABAD, BENGALURU, BHOPAL, BHUBANESHWAR, CHANDIGARH, CHENNAI, COIMBATORE, DEHRADUN, DELHI, FARIDABAD, GHAZIABAD, GUWAHATI, HARYNA, HUBLI, HYDERABAD, JAIPUR, JAMMU & KASHMIR, JAMSHEDPUR, KOCHI, KOLKATA, LUCKNOW, MADURAI, MUMBAI, NAGPUR, NOIDA, PARWANOO, PATNA, PUNE, RAIPUR, RAJKOT, SURAT, VIJAYAWADA.