

भारतीय मानक

IS 18443 : 2024

Indian Standard

(Superseding IS/IEC 60336 : 2005)

चिकित्सा विद्युत उपकरण — चिकित्सा
निदान के लिए एक्स-रे ट्यूब असेंबली —
फोकल स्पॉट आयाम और संबंधित
विशेषताएँ

(IEC 60336 : 2020, संशोधित)

Medical Electrical Equipment —
X-Ray Tube Assemblies for Medical
Diagnosis — Focal Spot Dimensions
and Related Characteristics

(IEC 60336 : 2020, MOD)

ICS 11.040.50

© BIS 2024

© IEC 2020



भारतीय मानक ब्यूरो

BUREAU OF INDIAN STANDARDS

मानक भवन, 9 बहादुर शाह ज़फर मार्ग, नई दिल्ली - 110002

MANAK BHAVAN, 9 BAHADUR SHAH ZAFAR MARG
NEW DELHI - 110002

www.bis.gov.in www.standardsbis.in

August 2024

Price Group 14

NATIONAL FOREWORD

This Indian Standard which is modified adoption of IEC 60336 : 2020 + COR 1 'Medical electrical equipment — X-ray tube assemblies for medical diagnosis — Focal spot dimensions and related characteristics' issued by the International Electrotechnical Commission (IEC) was adopted by the Bureau of Indian Standards on the recommendation of the Electromedical, Diagnostic Imaging and Radiotherapy Equipment Sectional Committee and approval of the Medical Equipment and Hospital Planning Division Council.

This standard was first published in 1986 as IS 12024 which was based on IEC Pub 336 (1982) 'Characteristics of focal spots in diagnostic X-ray tube assemblies for medical use'. It was superseded by IS/IEC 60336 : 2005 which was an identical adoption of IEC 60336 : 2005 'Medical electrical equipment — X-ray tube assemblies for medical diagnosis — Characteristics of focal spots'. This publication supersedes IS/IEC 60336 : 2005.

Corrigendum 1 issued in 2022 to IEC 60336 : 2020 has been incorporated at the end of this publication.

The text of IEC standard has been approved as suitable for publication as an Indian Standard without deviations. Certain conventions are, however, not identical to those used in Indian Standards. Attention is particularly drawn to the following:

- a) Wherever the words 'International Standard' appear referring to this standard, they should be read as 'Indian Standard'; and
- b) Comma (,) has been used as a decimal marker while in Indian Standards, the current practice is to use a point (.) as the decimal marker.

In this adopted standard, reference appears to certain International Standards for which Indian Standard also exists. The corresponding Indian Standards, which are to be substituted in their respective places, are listed below along with their degree of equivalence for the editions indicated:

<i>International Standard</i>	<i>Corresponding Indian Standard</i>	<i>Degree of Equivalence</i>
IEC 60601-1 : 2005 Medical electrical equipment — Part 1: General requirements for basic safety and essential performance + AMD 1 : 2012 + AMD 2 : 2020	IS 13450 (Part 1) : 2024 Medical electrical equipment: Part 1 General requirements for basic safety and essential performance (IEC 60601-1 : 2020, MOD) (<i>third revision</i>)	Modified
IEC 60601-1-3 : 2008 Medical electrical equipment — Part 1-3: General requirements for basic safety and essential performance — Collateral standard: Radiation protection in diagnostic X-ray equipment + AMD 1 : 2013	IS 13450 (Part 1/Sec 3) : 2024 Medical electrical equipment: Part 1 General requirements for basic safety and essential performance, Section 3 Radiation protection in diagnostic X-ray equipment (IEC 60601-1-3 : 2021, MOD) (<i>first revision</i>)	Modified
IEC TR 60788 : 2004 Medical electrical equipment — Glossary of defined terms	IS/IEC/TR 60788 : 2004 Medical electrical equipment — Glossary of defined terms	Identical

[*\(Continued on third cover\)*](#)

CONTENTS

1	Scope	1
2	Normative references	1
3	Terms and definitions	1
4	Determinations for the evaluation of the FOCAL SPOT characteristics	3
4.1	Statement of the FOCAL SPOT characteristics	3
4.2	Longitudinal axis of the X-RAY TUBE ASSEMBLY	3
4.3	REFERENCE AXIS of the X-RAY TUBE ASSEMBLY	3
4.4	Direction of evaluation for the FOCAL SPOT length	3
4.5	Direction of evaluation for the FOCAL SPOT width	4
4.6	Directions of evaluation for distorted FOCAL SPOTS	4
5	FOCAL SPOT camera set-up	4
5.1	Overview	4
5.2	Diaphragm of the SLIT CAMERA	4
5.3	Diaphragm of the PINHOLE CAMERA	5
5.4	Receptor	6
5.5	Test arrangement	6
5.5.1	Position of the slit or pinhole diaphragm normal to the REFERENCE AXIS	6
5.5.2	Position of the slit or pinhole diaphragm along the REFERENCE AXIS	7
5.5.3	Orientation of the slit or pinhole diaphragm	8
5.5.4	Position and orientation of the receptor of the DIGITAL FOCAL SPOT DETECTOR	8
5.6	Total uncertainty of the camera set-up	9
6	Production of RADIOGRAMS	10
6.1	Overview	10
6.2	Operating conditions	10
6.2.1	X-RAY TUBE ASSEMBLY	10
6.2.2	LOADING FACTORS	10
6.2.3	Special LOADING FACTORS	11
6.2.4	Special arrangements	11
6.3	Production of FOCAL SPOT SLIT RADIOGRAMS, FOCAL SPOT PINHOLE RADIOGRAMS and FOCAL SPOT LINE SPREAD FUNCTIONS	11
6.3.1	DIGITAL FOCAL SPOT DETECTOR requirements for FOCAL SPOT SLIT RADIOGRAMS	11
6.3.2	DIGITAL FOCAL SPOT DETECTOR requirements for FOCAL SPOT PINHOLE RADIOGRAMS	11
6.3.3	Determination of the RADIOGRAMS and of the LINE SPREAD FUNCTIONS	12
6.4	Statement of compliance of the FOCAL SPOT PINHOLE RADIOGRAM	12
6.5	Statement of compliance of LINE SPREAD FUNCTIONS	12
7	Determination of FOCAL SPOT dimensions and NOMINAL FOCAL SPOT VALUES	13
7.1	Overview	13
7.2	Measurement and determination of FOCAL SPOT dimensions	13
7.3	Specified NOMINAL FOCAL SPOT VALUES	13
7.3.1	Nominal values	13
7.3.2	Actual dimensions	14
7.4	Statement of compliance	15
7.5	Marking of compliance	15

8	Determination of the MODULATION TRANSFER FUNCTION	16
8.1	Overview.....	16
8.2	Calculation and presentation of the MODULATION TRANSFER FUNCTION.....	16
8.3	Statement of compliance.....	16
9	Alternative measurement methods for determining NOMINAL FOCAL SPOT VALUES.....	17
	Annex A (informative) Alignment to the REFERENCE AXIS.....	18
	Annex B (informative) FOCAL SPOT STAR RADIOGRAM	20
B.1	Overview.....	20
B.2	Test EQUIPMENT	20
B.2.1	STAR PATTERN CAMERA.....	20
B.2.2	RADIOGRAPHIC FILM.....	21
B.2.3	Position of the STAR PATTERN CAMERA normal to the REFERENCE AXIS	21
B.2.4	Position of the STAR PATTERN CAMERA in REFERENCE DIRECTION	21
B.2.5	Alignment of the STAR PATTERN CAMERA.....	21
B.2.6	Position of the RADIOGRAPHIC FILM	22
B.2.7	Operating conditions.....	22
B.2.8	Production of the FOCAL SPOT STAR RADIOGRAM.....	22
	Annex C (informative) STAR PATTERN RESOLUTION LIMIT.....	23
C.1	Overview.....	23
C.2	Measurement	23
C.3	Determination of the STAR PATTERN RESOLUTION LIMIT.....	24
C.3.1	Determination of the magnification.....	24
C.3.2	STAR PATTERN RESOLUTION LIMIT for standard magnification	24
C.3.3	STAR PATTERN RESOLUTION LIMIT for finite magnification	24
C.3.4	Presentation of STAR PATTERN RESOLUTION LIMIT	25
	Annex D (informative) BLOOMING VALUE	26
D.1	Overview.....	26
D.2	Determination of the BLOOMING VALUE.....	26
	Annex E (informative) Historical background.....	27
E.1	Overview.....	27
E.2	First edition (1970).....	27
E.3	Second edition (1982).....	27
E.4	Third edition (1993).....	27
E.5	Fourth edition (2005)	30
E.6	Fifth edition (2020).....	31
E.6.1	Overview	31
E.6.2	Fifth edition technical details	31
	Bibliography.....	36
	Index of defined terms	37
	Figure 1 – Directions of evaluation over distorted FOCAL SPOTS	4
	Figure 2 – Essential dimensions of the slit diaphragm.....	5
	Figure 3 – Essential dimensions of the pinhole diaphragm	6
	Figure 4 – Position of the centre of the slit or pinhole diaphragm (marked as x in the figure) with respect to the REFERENCE AXIS	7
	Figure 5 – Reference dimensions and planes.....	8

Figure 6 – Alignment of the receptor of the DIGITAL FOCAL SPOT DETECTOR with respect to the slit diaphragm	9
Figure 7 – LINE SPREAD FUNCTION	13
Figure 8 – Graphical symbols – FOCAL SPOTS	15
Figure A.1 – REFERENCE AXIS and directions of evaluation	18
Figure A.2 – PROJECTION of the ACTUAL FOCAL SPOT on the IMAGE RECEPTION PLANE	19
Figure B.1 – Essential dimensions of the star test pattern	20
Figure B.2 – Alignment of the STAR PATTERN CAMERA	22
Figure C.1 – Illustration of the zones of minimum modulation	23
Figure E.1 – LSFs for a typical X-RAY TUBE with small FOCAL SPOT (< 0,3 mm)	28
Figure E.2 – LSFs for a typical X-RAY TUBE with large FOCAL SPOT ($\geq 0,3$ mm)	29
Figure E.3 – Corresponding MTFs for the LSFs in Figure E.2	29
Figure E.4 – Percentage error of 15 % width	32
Figure E.5 – Percentage error of LINE SPREAD FUNCTION width at 15 %	33
Figure E.6 – Influence of the direction of evaluation on MTF-quality and on LINE SPREAD FUNCTION width at 15 %	34
Table 1 – Recommended enlargement for RADIOGRAMS	9
Table 2 – LOADING FACTORS	10
Table 3 – Maximum permissible values of FOCAL SPOT dimensions for NOMINAL FOCAL SPOT VALUES	14
Table C.1 – Standard magnifications for STAR PATTERN RESOLUTION LIMIT	24
Table D.1 – LOADING FACTORS for the determination of the BLOOMING VALUE	26
Table E.1 – Methods for evaluation of specific aspects characterising the FOCAL SPOT	31

*Indian Standard***MEDICAL ELECTRICAL EQUIPMENT — X-RAY TUBE ASSEMBLIES FOR MEDICAL DIAGNOSIS — FOCAL SPOT DIMENSIONS AND RELATED CHARACTERISTICS
(IEC 60336 : 2020, MOD)****1 Scope**

This document applies to FOCAL SPOTS in medical diagnostic X-RAY TUBE ASSEMBLIES for medical use, operating at X-RAY TUBE VOLTAGES up to and including 150 kV.

This document describes the test methods employing digital detectors for determining:

- a) FOCAL SPOT dimensions in terms of NOMINAL FOCAL SPOT VALUES, ranging from 0,1 to 3,0;
- b) LINE SPREAD FUNCTIONS;
- c) one-dimensional MODULATION TRANSFER FUNCTIONS;
- d) FOCAL SPOT PINHOLE RADIOGRAMS,

and the means for indicating compliance.

In informative annexes, STAR PATTERN imaging and BLOOMING VALUE are described.

2 Normative references

The following documents are referred to in the text in such a way that some or all of their content constitutes requirements of this document. For dated references, only the edition cited applies. For undated references, the latest edition of the referenced document (including any amendments) applies.

IEC 60417, *Graphical symbols for use on equipment* (available at <http://www.graphical-symbols.info/equipment>)

IEC 60601-1:2005, *Medical electrical equipment – Part 1: General requirements for basic safety and essential performance*
IEC 60601-1:2005/AMD1:2012

IEC 60601-1-3:2008, *Medical electrical equipment – Part 1-3: General requirements for basic safety and essential performance – Collateral Standard: Radiation protection in diagnostic X-ray equipment*
IEC 60601-1-3:2008/AMD1:2013

IEC 60613:2010, *Electrical and loading characteristics of X-ray tube assemblies for medical diagnosis*

IEC TR 60788:2004, *Medical electrical equipment – Glossary of defined terms*

3 Terms and definitions

For the purposes of this document, terms and definitions given in IEC TR 60788:2004, IEC 60613:2010, IEC 60601-1:2005 and IEC 60601-1:2005/AMD1:2012, IEC 60601-1-3:2008 and IEC 60601-1-3:2008/AMD1:2013 and the following apply.

ISO and IEC maintain terminological databases for use in standardization at the following addresses:

- IEC Electropedia: available at <http://www.electropedia.org/>
- ISO Online browsing platform: available at <http://www.iso.org/obp>

3.1

ACTUAL FOCAL SPOT

area on the surface of the TARGET that intercepts the beam of accelerated particles

Note 1 to entry: Regarding accelerated particles, only the intended primary beam is included.

3.2

BLOOMING VALUE

ratio of two resolution limits obtained under specific LOADING conditions

Note 1 to entry: The BLOOMING VALUE is a characteristic of the EFFECTIVE FOCAL SPOT of an X-RAY TUBE.

3.3

DIGITAL FOCAL SPOT DETECTOR

pixel-array device applied to FOCAL SPOT analysis of X-RAY TUBE ASSEMBLIES, providing a digital output value per pixel which is linearly related to the input X-ray intensity

3.4

EFFECTIVE FOCAL SPOT

FOCAL SPOT

perpendicular PROJECTION of the ACTUAL FOCAL SPOT on the REFERENCE PLANE

3.5

FOCAL SPOT PINHOLE RADIOGRAM

RADIOGRAM obtained by means of a PINHOLE CAMERA, showing the shape and orientation of an EFFECTIVE FOCAL SPOT, and the spatial distribution of intensity of radiation across it

3.6

FOCAL SPOT SLIT RADIOGRAM

RADIOGRAM obtained by means of a SLIT CAMERA, showing the distribution, across an EFFECTIVE FOCAL SPOT, in the direction normal to the length of the slit, of the intensity of the radiation emitted

3.7

FOCAL SPOT STAR RADIOGRAM

RADIOGRAM obtained by means of a STAR PATTERN CAMERA for the determination of the STAR PATTERN RESOLUTION LIMIT in one or more directions across an EFFECTIVE FOCAL SPOT

3.8

NOMINAL FOCAL SPOT VALUE

dimensionless numerical value having a specific relation to the dimensions of the EFFECTIVE FOCAL SPOT of an X-RAY TUBE, measured under specific conditions

3.9

PINHOLE CAMERA

assembly of EQUIPMENT used to obtain a FOCAL SPOT PINHOLE RADIOGRAM

3.10

REFERENCE AXIS

<RADIATION SOURCE> line in the REFERENCE DIRECTION through the centre of the RADIATION SOURCE

3.11**REFERENCE DIRECTION**

<RADIATION SOURCE> specified direction to which characteristics such as TARGET ANGLE, RADIATION FIELD and specifications with respect to the imaging quality of the RADIATION SOURCE are referenced

3.12**REFERENCE PLANE**

<diagnostic X-RAY EQUIPMENT for an EFFECTIVE FOCAL SPOT> plane perpendicular to the REFERENCE DIRECTION containing the point at which the REFERENCE AXIS intersects with the ACTUAL FOCAL SPOT

Note 1 to entry: By convention, the point of intersection forms the centre of the EFFECTIVE FOCAL SPOT.

3.13**SLIT CAMERA**

assembly of EQUIPMENT used to obtain a FOCAL SPOT SLIT RADIOGRAM

3.14**STAR PATTERN CAMERA**

assembly of EQUIPMENT used to obtain a FOCAL SPOT STAR RADIOGRAM

3.15**STAR PATTERN RESOLUTION LIMIT**

characteristic of the FOCAL SPOT of an X-RAY TUBE, which represents the highest spatial frequency that can be resolved under specific measuring conditions

3.16**TARGET**

part of an X-RAY TUBE or a PARTICLE ACCELERATOR onto which is directed a beam of accelerated particles to produce IONIZING RADIATION or other particles

4 Determinations for the evaluation of the FOCAL SPOT characteristics**4.1 Statement of the FOCAL SPOT characteristics**

The FOCAL SPOT characteristics shall be stated for two normal directions of evaluation referred to as the length direction and width direction. An illustration for Clause 4 can be found in Figure A.1.

4.2 Longitudinal axis of the X-RAY TUBE ASSEMBLY

Generally, the longitudinal axis can be identified unambiguously. If the X-RAY TUBE ASSEMBLY does not have an identifiable longitudinal axis or if it is specified otherwise by the MANUFACTURER, the longitudinal axis shall be specified together with the FOCAL SPOT characteristics.

4.3 REFERENCE AXIS of the X-RAY TUBE ASSEMBLY

If not specified otherwise, the REFERENCE AXIS is normal to the longitudinal axis and intersects both the centre of the ACTUAL FOCAL SPOT and the longitudinal axis of the X-RAY TUBE ASSEMBLY.

4.4 Direction of evaluation for the FOCAL SPOT length

The direction of evaluation for the FOCAL SPOT length is normal to the REFERENCE AXIS in the plane given by the REFERENCE AXIS and the longitudinal axis of the X-RAY TUBE ASSEMBLY.

NOTE The direction of evaluation for the FOCAL SPOT length is normally parallel to the longitudinal axis of the X-RAY TUBE ASSEMBLY. See Figure A.1.

4.5 Direction of evaluation for the FOCAL SPOT width

The direction of evaluation for the FOCAL SPOT width is normal to the longitudinal axis of the X-RAY TUBE ASSEMBLY and normal to the REFERENCE AXIS.

4.6 Directions of evaluation for distorted FOCAL SPOTS

If the PROJECTION of the EFFECTIVE FOCAL SPOT in the REFERENCE DIRECTION is distorted, the direction of evaluation over the width may be chosen normal to the pronounced orientation of the regions of highest radiation intensity, which is usually the direction over the FOCAL SPOT showing the smallest width (see Figure 1).

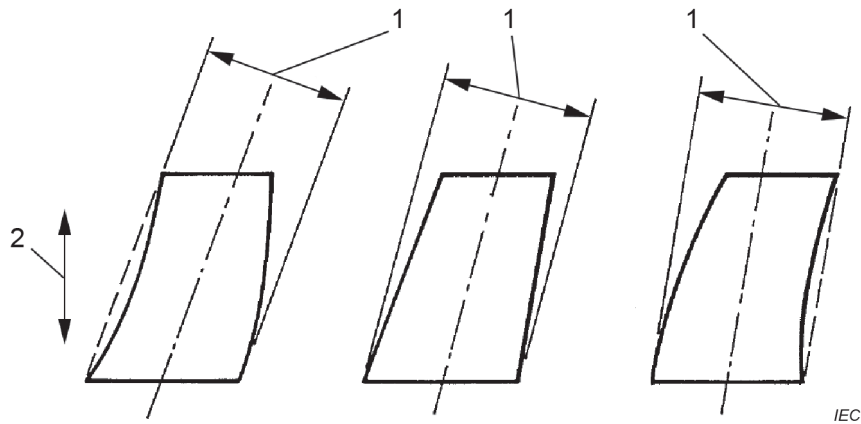

Key

- 1 direction over the width
- 2 direction over the length

Figure 1 – Directions of evaluation over distorted FOCAL SPOTS

The direction of evaluation over the width of distorted FOCAL SPOTS shall not exceed $\pm 20^\circ$ from the standard evaluation direction as specified in 4.5. If a direction of evaluation other than the standard direction is used to determine the FOCAL SPOT width, then the value of this direction shall be stated as part of the statement of compliance with this document. The angle of such direction of evaluation is counted positive if the direction of evaluation has been rotated clockwise, as seen from the FOCAL SPOT.

5 FOCAL SPOT camera set-up

5.1 Overview

Clause 5 deals with the design requirements of the camera: the diaphragm, the receptor and the position and orientation of the diaphragm and the receptor.

5.2 Diaphragm of the SLIT CAMERA

The diaphragm of the SLIT CAMERA shall be made from materials with high ATTENUATION properties and shall have dimensions as given in Figure 2.

Suitable materials are for example:

- tungsten;
- tantalum;
- alloy of gold and 10 % platinum;
- alloy of tungsten and 10 % rhenium;
- alloy of platinum and 10 % iridium.

Dimensions in millimetres

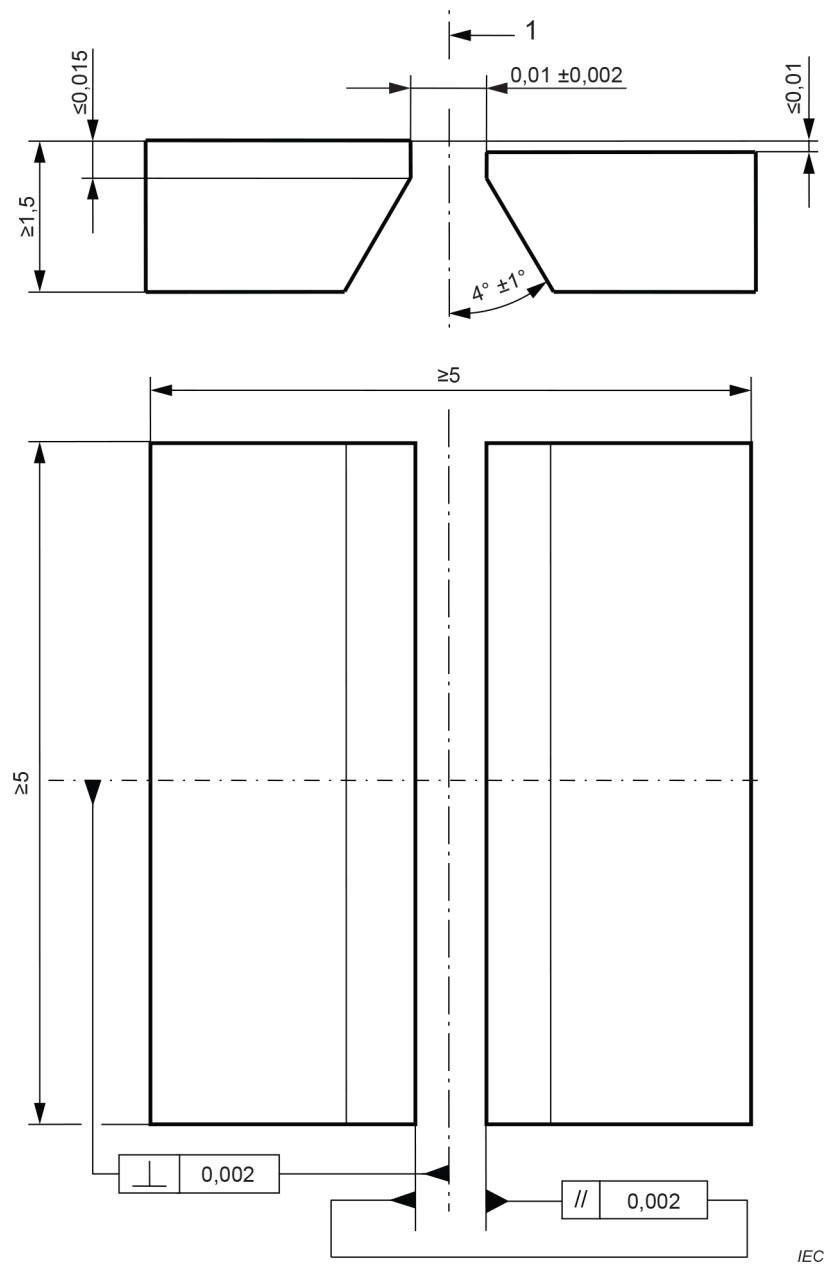

Key

1 axis of symmetry

Not drawn to scale.

Figure 2 – Essential dimensions of the slit diaphragm

5.3 Diaphragm of the PINHOLE CAMERA

The diaphragm of the PINHOLE CAMERA shall be constructed from materials with high ATTENUATION and shall have dimensions as given in Figure 3.

Suitable materials are for example:

- tungsten;
- tantalum;
- alloy of gold and 10 % platinum;

- alloy of tungsten and 10 % rhenium;
- alloy of platinum and 10 % iridium.

Dimensions in millimetres

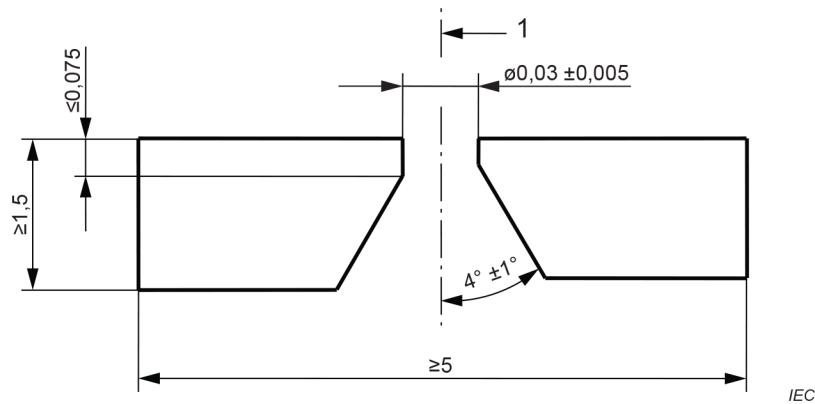

Key

1 axis of symmetry

Not drawn to scale.

Figure 3 – Essential dimensions of the pinhole diaphragm

5.4 Receptor

The receptor is the X-RAY sensitive part of the DIGITAL FOCAL SPOT DETECTOR. The DIGITAL FOCAL SPOT DETECTOR is a pixel-array device providing a digital output value per pixel which is linearly related to the input X-ray intensity. Two types are specified for use in this document (see also Figure 6):

- 1D-detector; the receptor consists of one pixel-array. This detector shall be applied to obtain the FOCAL SPOT SLIT RADIOGRAMS (see 6.3.1).

NOTE The 1D-detector is sometimes referred to as "line-detector".

- 2D-detector; the receptor consists of a two-dimensional matrix of pixels. This detector may be applied to obtain the FOCAL SPOT SLIT RADIOGRAMS (see 6.3.1), and it shall be applied to obtain the FOCAL SPOT PINHOLE RADIOGRAM (see 6.3.2).

5.5 Test arrangement

5.5.1 Position of the slit or pinhole diaphragm normal to the REFERENCE AXIS

The slit or pinhole diaphragm shall be positioned in such a way that the distance from its centre to the REFERENCE AXIS is within 0,2 mm per 100 mm of *m* (as indicated in Figure 4).

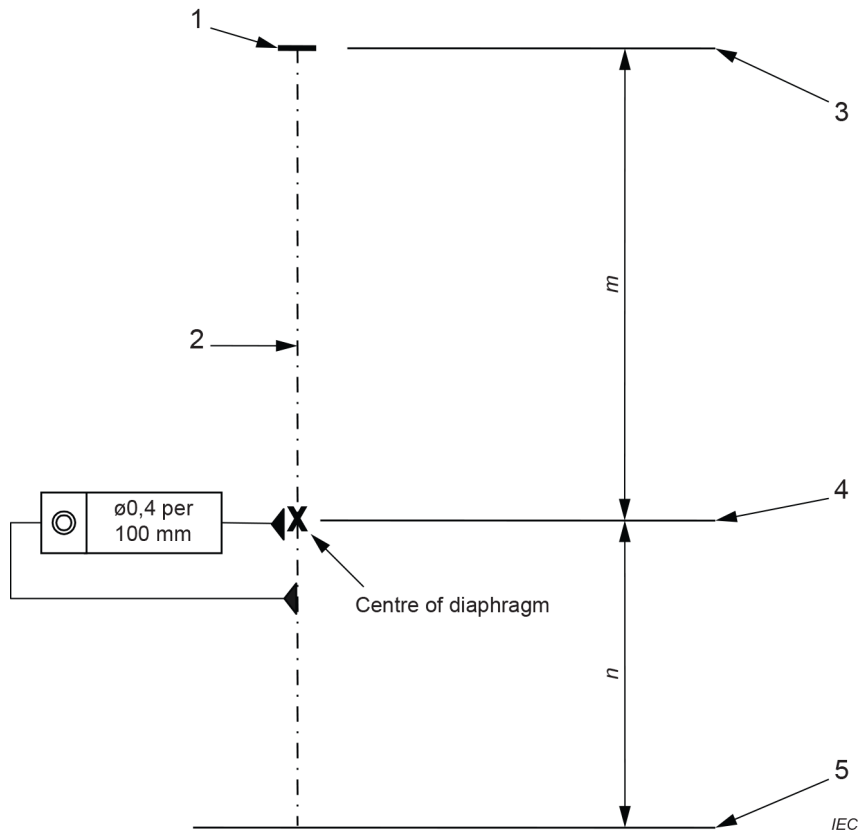

Key

- 1 EFFECTIVE FOCAL SPOT
- 2 REFERENCE AXIS
- 3 REFERENCE PLANE
- 4 incident face of the slit or pinhole diaphragm
- 5 IMAGE RECEPTION PLANE

Figure 4 – Position of the centre of the slit or pinhole diaphragm (marked as x in the figure) with respect to the REFERENCE AXIS

5.5.2 Position of the slit or pinhole diaphragm along the REFERENCE AXIS

The incident face of the slit or pinhole diaphragm shall be placed at a distance from the REFERENCE PLANE sufficient to ensure that the variation of the enlargement over the extension of the ACTUAL FOCAL SPOT along the REFERENCE AXIS does not exceed $\pm 5\%$.

In Figure 5, the determining parameters are indicated, namely:

- k is the distance from the REFERENCE PLANE to the edge of the ACTUAL FOCAL SPOT farthest away from the slit or pinhole diaphragm;
- p is the distance from the REFERENCE PLANE to the edge of the ACTUAL FOCAL SPOT closest to the slit or pinhole diaphragm;
- m is the distance from the REFERENCE PLANE to the incident face of the diaphragm;
- n is the distance from the incident face of the diaphragm to the IMAGE RECEPTION PLANE;
- E is the enlargement given by n/m .

NOTE Whether the requirement on the variation of the enlargement is met depends on the values of p , k and m – whereas p and k depend in turn on the ANODE ANGLE and the ACTUAL FOCAL SPOT length. As an example, for $m = 100$, maximum p and k is 5 mm.

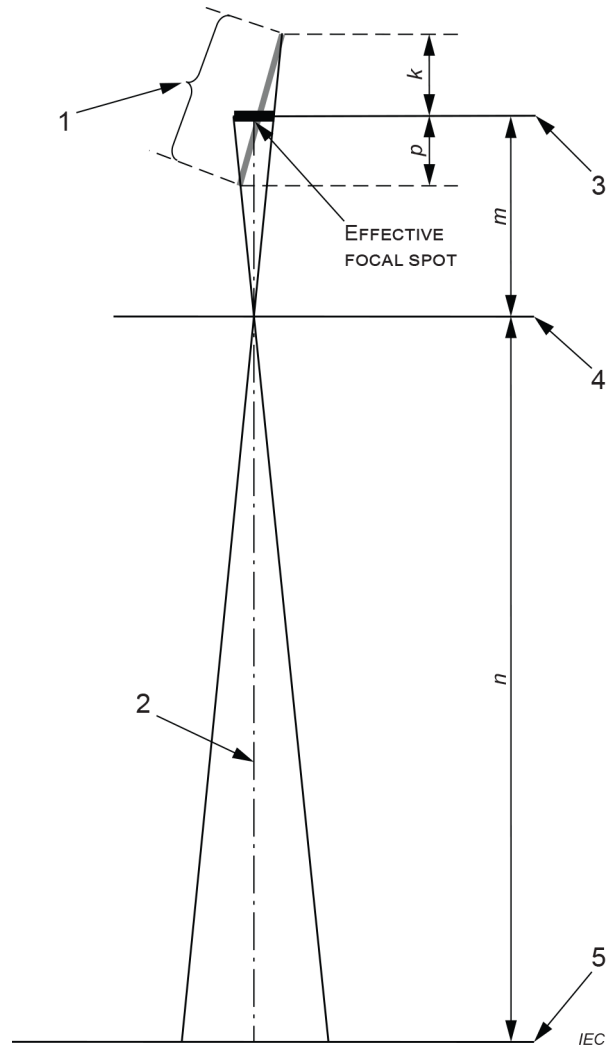

Key

- 1 ACTUAL FOCAL SPOT
- 2 REFERENCE AXIS
- 3 REFERENCE PLANE
- 4 incident face of the slit or pinhole diaphragm
- 5 IMAGE RECEPTION PLANE

Figure 5 – Reference dimensions and planes

5.5.3 Orientation of the slit or pinhole diaphragm

The axis of symmetry (see Figure 2 and Figure 3) shall be aligned with the REFERENCE AXIS forming an angle that is smaller than 1°.

For the production of a pair of FOCAL SPOT SLIT RADIOGRAMS, the slit diaphragm shall be orientated such that the length of the slit is normal to the direction of evaluation within ±1°.

5.5.4 Position and orientation of the receptor of the DIGITAL FOCAL SPOT DETECTOR

The receptor plane of the DIGITAL FOCAL SPOT DETECTOR (Figure 4 and Figure 5) shall be placed normal to the REFERENCE AXIS within ±1°.

The enlargement $E = n/m$ (Figure 4 and Figure 5) shall be determined with an accuracy to within ±3 %.

NOTE 1 For the choice of the enlargement, the following can be considered: with an infinitely narrow slit or pinhole, a true image of the FOCAL SPOT would be obtained. However, the finite size of the slit or pinhole will broaden the FOCAL SPOT image. Table 1 gives recommendations for the enlargement factor E . E is then larger for smaller FOCAL SPOTS.

Table 1 – Recommended enlargement for RADIOGRAMS

NOMINAL FOCAL SPOT VALUE (f) ^a	Enlargement ($E = n / m$) ^b
$f \leq 0,4$	$E \geq 3$
$0,4 < f < 1,1$	$E \geq 2$
$1,1 \leq f$	$E \geq 1$
^a See 7.3.	
^b See Figure 4 and Figure 5.	

The direction of evaluation for the FOCAL SPOT width or length shall be oriented normal to the direction of the diaphragm slit to within $\pm 1^\circ$. In Figure 6, such alignment of the diaphragm slit and 1D-detector is indicated. Also, in Figure 6, for the 2D-detector, the output of such pixels is combined to simulate the 1D-detector configuration.

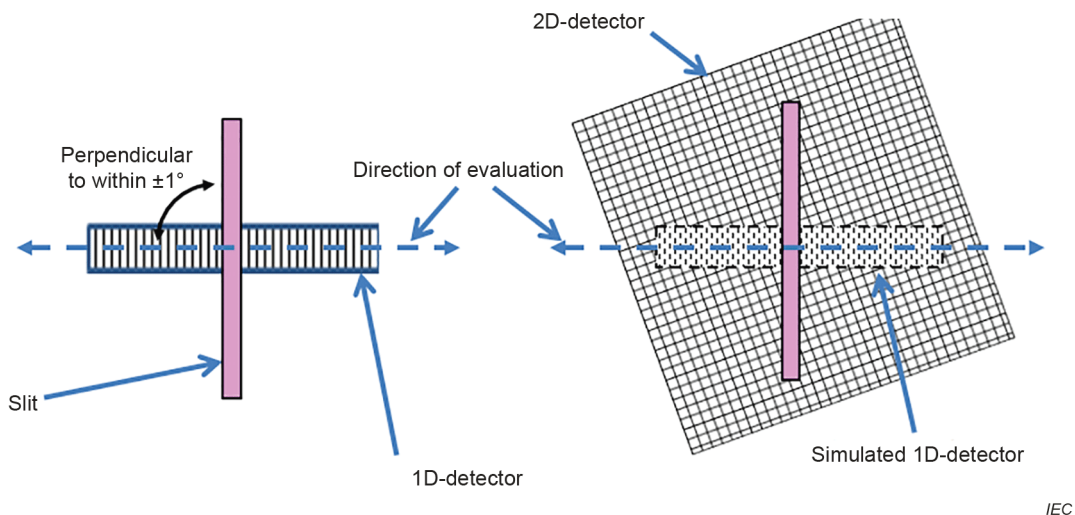

NOTE Objects not to scale – for orientation only.

Figure 6 – Alignment of the receptor of the DIGITAL FOCAL SPOT DETECTOR with respect to the slit diaphragm

NOTE 1 As presented in Figure 6, the direction of the arrays of the 2D-detector is not critical, as with a well-designed detector, following the recommendations for the number of pixels in 6.3.1 and 6.3.2 the pixels are small enough to not influence the deduced NOMINAL FOCAL SPOT VALUES significantly.

NOTE 2 If the 1D-detector is not perfectly normal to the direction of the slit diaphragm, then the length of the pixel will lead to an effective width of the pixel which is larger than the actual pixel-width. This effect can influence the accuracy of the determination. It is good practice that the effective width of the pixel normal to the direction of the slit diaphragm is not larger than twice the actual width of the pixel. The effective width of the pixels has a similar effect on the accuracy as the aperture of the optical densitometer as applied in 7.2 of IEC 60336:2005. The requirements for the aperture of the densitometer in IEC 60336:2005 are translated into this recommendation for the effective pixel-width and for the alignment and length of the pixels.

5.6 Total uncertainty of the camera set-up

The total uncertainty of the camera set-up stems from the geometrical tolerances of the camera, i.e.

- position of the diaphragm normal to the REFERENCE AXIS (see 5.5.1);

- b) position of the diaphragm along the REFERENCE AXIS (see 5.5.2);
- c) alignment of the axis of symmetry of the diaphragm with the REFERENCE AXIS (see 5.5.3);
- d) position (distance and perpendicularity) of the DIGITAL FOCAL SPOT DETECTOR (see 5.5.4).

NOTE The typical total uncertainty of the camera set-up will lead to an error in the width of the LINE SPREAD FUNCTION deduced from the FOCAL SPOT SLIT RADIOGRAM (see 7.2) of the order of 5 %. The MANUFACTURER can choose a different set of geometrical tolerances, as long as the requirement in Clause 9 is met.

6 Production of RADIOGRAMS

6.1 Overview

Clause 6 deals with production of FOCAL SPOT SLIT RADIOGRAMS and FOCAL SPOT PINHOLE RADIOGRAMS, which shall be produced using a FOCAL SPOT camera according to Clause 5, while following the operating conditions in 6.2 and 6.3.

NOTE Adequate shielding is usually needed to minimize the effect of STRAY RADIATION on the RADIOGRAM.

FOCAL SPOT PINHOLE RADIOGRAMS have an informative character only, for showing the distribution of radiant intensity over the FOCAL SPOT.

The method of indicating compliance with this document of FOCAL SPOT RADIOGRAMS is described in 6.4. The method of indicating compliance with this document of LINE SPREAD FUNCTIONS is described in 6.5.

6.2 Operating conditions

6.2.1 X-RAY TUBE ASSEMBLY

The X-RAY TUBE shall be installed in an X-RAY TUBE HOUSING of the type for which it is specified for NORMAL USE or it shall be placed under equivalent mounting and operating conditions as far as these can influence the results of the test.

All the materials belonging to the X-RAY TUBE ASSEMBLY in NORMAL USE shall be installed. No ADDITIONAL FILTRATION shall be used to decrease the X-ray output flux unless it is verified that the ADDITIONAL FILTRATION has no significant effect on the LINE SPREAD FUNCTION (see 6.3.3).

6.2.2 LOADING FACTORS

FOCAL SPOT SLIT RADIOGRAMS or FOCAL SPOT PINHOLE RADIOGRAMS for X-RAY TUBE ASSEMBLIES used in PROJECTION RADIOGRAPHY or in COMPUTED TOMOGRAPHY shall be obtained with constant LOADING FACTORS in accordance with Table 2.

Table 2 – LOADING FACTORS

	NOMINAL X-RAY TUBE VOLTAGE kV	Required X-RAY TUBE VOLTAGE	Exposure time	Required X-RAY TUBE power
RADIOGRAPHY other than COMPUTED TOMOGRAPHY	$U < 75$	NOMINAL X-RAY TUBE VOLTAGE	As a guideline see recommendations in 6.3.1 b) and c) or 6.3.2 b) and c)	50 % of the NOMINAL RADIOGRAPHIC ANODE INPUT POWER
	$75 \leq U \leq 150$	75 kV		50 % of the NOMINAL CT ANODE INPUT POWER
COMPUTED TOMOGRAPHY		120 kV		

6.2.3 Special LOADING FACTORS

If the LOADING FACTORS according to Table 2 do not fall within the RADIOGRAPHIC RATINGS for the X-RAY TUBE concerned or if they otherwise do not cover the typical special applications of specified NORMAL USE of the X-RAY TUBE, LOADING FACTORS shall be chosen to correspond to those specific conditions. In this case, the LOADING FACTORS under which the FOCAL SPOT SLIT RADIOGRAMS or FOCAL SPOT PINHOLE RADIOGRAMS were obtained shall be stated in the statement of compliance together with the characteristics.

In particular cases, it may be appropriate to state the characteristics of a FOCAL SPOT under additional LOADING conditions.

6.2.4 Special arrangements

If, for the purpose of production of suitable FOCAL SPOT SLIT RADIOGRAMS, arrangements were made for the adjustment and alignment of either the SLIT CAMERA or X-RAY TUBE ASSEMBLY, or if special electrical or LOADING conditions prevailed, details shall be stated together with the characteristics in the statement of compliance.

6.3 Production of FOCAL SPOT SLIT RADIOGRAMS, FOCAL SPOT PINHOLE RADIOGRAMS and FOCAL SPOT LINE SPREAD FUNCTIONS

6.3.1 DIGITAL FOCAL SPOT DETECTOR requirements for FOCAL SPOT SLIT RADIOGRAMS

The spatial range of the FOCAL SPOT SLIT RADIOGRAM shall be such that further extension of the spatial range does not significantly change the result for the 15 % width.

NOTE In general, the spatial range of three times the 15 % width of the LINE SPREAD FUNCTION is sufficient.

Discretization errors are inherent to digital detectors and the subsequent signal processing. These errors will lead to LINE SPREAD FUNCTION widths which are larger than in the ideal case. The following choice of parameters is recommended in order to limit the error induced by discretization to about 1 %.

- a) The number of pixels over the 15 % width of the LINE SPREAD FUNCTION is at least 30, and linear interpolation is applied. If linear interpolation is not applied, the number of pixels should be at least 60.
- b) The number of levels between the background level and the maximum signal of the LINE SPREAD FUNCTION is 200 or more.
- c) The signal to noise ratio is 200 or better.

See also E.6.2 a).

6.3.2 DIGITAL FOCAL SPOT DETECTOR requirements for FOCAL SPOT PINHOLE RADIOGRAMS

The spatial range of the FOCAL SPOT PINHOLE RADIOGRAM shall be such that that the outermost portions of the RADIOGRAM are well included, so that the true background-level of the RADIOGRAM can be perceived correctly.

NOTE 1 In general, in any direction, the spatial range of a minimum of three times the 15 % width of the pinhole RADIOGRAM is sufficient, as long as no significant side-lobes are present outside the principal lobe of the distribution.

NOTE 2 The following choice of parameters is applicable in order to obtain sufficiently accurate FOCAL SPOT PINHOLE RADIOGRAMS:

- a) the FOCAL SPOT PINHOLE RADIOGRAM width at 15 % of maximum intensity is covered by at least 60 pixels;
- b) the number of signal levels between the background level and the maximum signal is 200 or more;
- c) the signal to noise ratio is at least 100.

See also E.6.2 a).

6.3.3 Determination of the RADIOGRAMS and of the LINE SPREAD FUNCTIONS

In order to deduce the true value of the radiant intensity, the intensity distribution for the RADIOGRAM concerned shall be subtracted of its base level to obtain the effective zero-level, and shall be linearized, if necessary.

NOTE Due attention is also paid to such aspects as: saturation, stability, uniformity, dead pixels, and memory effects.

In order to deduce the true appropriate extension of the RADIOGRAM concerned, the axis values in the direction(s) of evaluation are divided by the enlargement E applied.

The FOCAL SPOT SLIT RADIOGRAMS thus corrected represent the FOCAL SPOT LINE SPREAD FUNCTIONS.

6.4 Statement of compliance of the FOCAL SPOT PINHOLE RADIOGRAM

If compliance with this document is to be stated for the presentation of a FOCAL SPOT PINHOLE RADIOGRAM, it shall be stated as follows:

FOCAL SPOT PINHOLE RADIOGRAM with enlargement of ...¹ according to IEC 60336:2020.

The following shall be stated in addition, if appropriate:	Subclause
REFERENCE AXIS	4.3
LOADING FACTORS	6.2.3
Special arrangements	6.2.4
Description of the longitudinal axis of the X-RAY TUBE ASSEMBLY	4.2

6.5 Statement of compliance of LINE SPREAD FUNCTIONS

If compliance with this document is to be stated for the presentation of a LINE SPREAD FUNCTION, it shall be stated as follows:

LINE SPREAD FUNCTION with enlargement of ...² according to IEC 60336:2020.

The following shall be stated in addition, if appropriate:	Subclause
REFERENCE AXIS	4.3
LOADING FACTORS	6.2.3
Special arrangements	6.2.4
Description of the longitudinal axis of the X-RAY TUBE ASSEMBLY	4.2
Direction of evaluation for the width of distorted FOCAL SPOTS	4.6

¹ Enlargement used and determined in accordance with 5.5.4.

² Enlargement used and determined in accordance with 5.5.4.

7 Determination of FOCAL SPOT dimensions and NOMINAL FOCAL SPOT VALUES

7.1 Overview

Clause 7 deals with the determination of the FOCAL SPOT dimensions on the basis of a pair of LINE SPREAD FUNCTIONS as described in 6.3.3.

Criteria for compliance with this document are included. The methods of indicating NOMINAL FOCAL SPOT VALUES in compliance with this document are indicated in 7.4 and 7.5.

7.2 Measurement and determination of FOCAL SPOT dimensions

The dimension of the FOCAL SPOT shall be determined as the size of the related LINE SPREAD FUNCTION according to 6.3.3 measured at 15 % of the peak value, as shown in Figure 7.

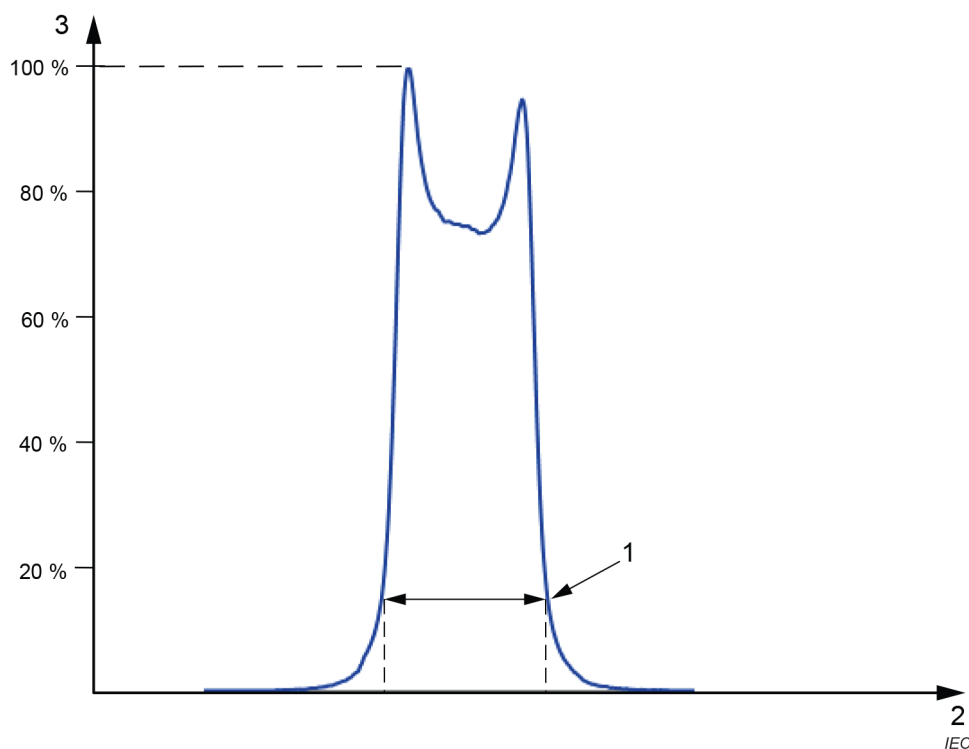

Key

- 1 width at 15 % max. signal intensity
- 2 spatial distribution along axis of evaluation
- 3 signal intensity

Figure 7 – LINE SPREAD FUNCTION

7.3 Specified NOMINAL FOCAL SPOT VALUES

7.3.1 Nominal values

Numerical NOMINAL FOCAL SPOT VALUES shall be assigned to the FOCAL SPOTS of each type of X-RAY TUBE ASSEMBLY as follows:

- from 0,1 to 0,25 in steps of 0,05;
- from 0,3 to 2,0 in steps of 0,1; and
- from 2,2 and upwards in steps of 0,2.

FOCAL SPOTS designed with different dimensions for length and width (typical for e.g. CT) may be assigned NOMINAL FOCAL SPOT VALUES consisting of a pair of numbers, for example 1,0 × 1,6, where the first number refers to the width of the EFFECTIVE FOCAL SPOT, and the second to the length of the EFFECTIVE FOCAL SPOT. This pair of values shall be stated using the same steps as given above.

7.3.2 Actual dimensions

The NOMINAL FOCAL SPOT VALUE shall correspond to the dimensions in the two directions of evaluation over the FOCAL SPOT so that the actual dimensions for the width and the length of the FOCAL SPOT determined in accordance with 7.2 are less than or equal to the maximum permissible dimensions for width and length for that NOMINAL FOCAL SPOT VALUE, given in Table 3.

For 0,1 NOMINAL FOCAL SPOT VALUE, the measured FOCAL SPOT dimensions shall not be smaller than 0,1 mm.

For FOCAL SPOTS with different NOMINAL FOCAL SPOT VALUES for length and width (typical for e.g. CT), each number shall be related to the NOMINAL FOCAL SPOT VALUE in Table 3 using only the width column.

For these determinations, no correction is required for measurement errors.

Table 3 – Maximum permissible values of FOCAL SPOT dimensions for NOMINAL FOCAL SPOT VALUES

NOMINAL FOCAL SPOT VALUE <i>f</i>	FOCAL SPOT DIMENSIONS – MAXIMUM PERMISSIBLE VALUES	
	mm	
	Width	Length
0,1	0,15	0,15
0,15	0,23	0,23
0,2	0,30	0,30
0,25	0,38	0,38
0,3	0,45	0,65
0,4	0,60	0,85
0,5	0,75	1,10
0,6	0,90	1,30
0,7	1,10	1,50
0,8	1,20	1,60
0,9	1,30	1,80
1,0	1,40	2,00
1,1	1,50	2,20
1,2	1,70	2,40
1,3	1,80	2,60
1,4	1,90	2,80
1,5	2,00	3,00
1,6	2,10	3,10
1,7	2,20	3,20
1,8	2,30	3,30
1,9	2,40	3,50

NOMINAL FOCAL SPOT VALUE <i>f</i>	FOCAL SPOT DIMENSIONS – MAXIMUM PERMISSIBLE VALUES	
	mm	
	Width	Length
2,0	2,60	3,70
2,2	2,90	4,00
2,4	3,10	4,40
2,6	3,40	4,80
2,8	3,60	5,20
3,0	3,90	5,60

NOTE For NOMINAL FOCAL SPOT VALUES 0,3 to 3,0, the MAXIMUM PERMISSIBLE VALUES for the length have been adjusted with the factor 0,7 (see Clause E.4).

7.4 Statement of compliance

If compliance with this document for one or more NOMINAL FOCAL SPOT VALUES is to be stated, this shall be done:

- as plain numbers (no units to be quoted), for example:
NOMINAL FOCAL SPOT VALUE 0,6 in accordance with IEC 60336:2020
- or as a pair of plain numbers for special application X-RAY TUBE ASSEMBLIES (see 7.3.1), no units to be quoted, for example:
NOMINAL FOCAL SPOT VALUES 1,0 × 0,6 in accordance with IEC 60336:2020

The following shall be stated in addition, if appropriate:	Subclause
REFERENCE AXIS	4.3
LOADING FACTORS	6.2.3
Special arrangements	6.2.4
Description of the longitudinal axis of the X-RAY TUBE ASSEMBLY	4.2
Direction of evaluation for the width of distorted FOCAL SPOTS	4.6

7.5 Marking of compliance

If compliance with this document for one or more specified NOMINAL FOCAL SPOT VALUES is to be marked on X-RAY TUBE ASSEMBLIES, or otherwise to be stated in a shortened form, this shall be done as shown in Figure 8, using the graphical symbols of IEC 60417, for example for three FOCAL SPOTS.

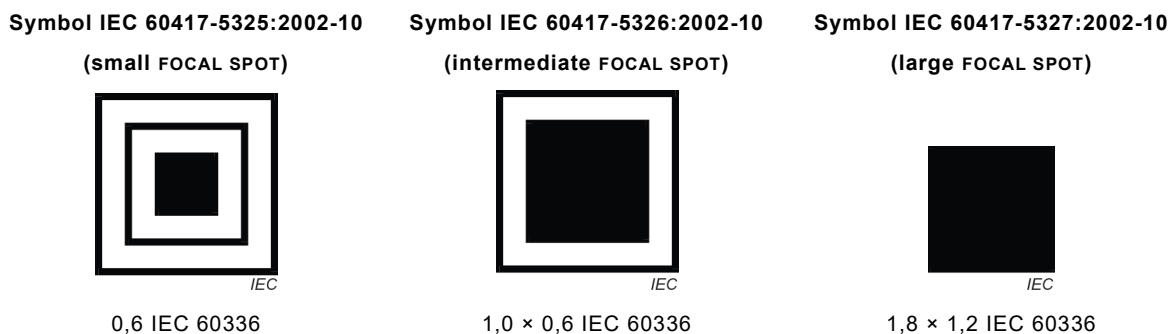

Figure 8 – Graphical symbols – FOCAL SPOTS

If an X-RAY TUBE ASSEMBLY produces more than one intermediate FOCAL SPOT, symbol IEC 60417-5326:2002-10 shall appear for each intermediate FOCAL SPOT.

8 Determination of the MODULATION TRANSFER FUNCTION

8.1 Overview

Clause 8 deals with the determination of the one-dimensional MODULATION TRANSFER FUNCTIONS belonging to the FOCAL SPOT of an X-RAY TUBE ASSEMBLY on the basis of a pair of LINE SPREAD FUNCTIONS as described in 6.3.3.

A method of presenting MODULATION TRANSFER FUNCTIONS and the statement of compliance with this document is included (8.2 and 8.3).

8.2 Calculation and presentation of the MODULATION TRANSFER FUNCTION

The one-dimensional MODULATION TRANSFER FUNCTION of a FOCAL SPOT shall be calculated by means of the magnitude of the Fourier transform of the LINE SPREAD FUNCTION according to 6.3.3. If the LSF is short, the MTF will be of low resolution. Before doing the Fourier transform, the LSF data shall in that case be extended by the standard mathematical method of "zero padding". The number of LSF data points shall in any case be at least 10 times the width of the LSF corresponding of the 15 % FOCAL SPOT size.

NOTE 1 The MODULATION TRANSFER FUNCTION thus deduced represents indeed a FOCAL SPOT characteristic, as the LINE SPREAD FUNCTION is defined in the REFERENCE PLANE.

The MODULATION TRANSFER FUNCTION shall be represented as a graph showing the magnitude of the Fourier transform as a function of spatial frequency. The graph shall use a linear scale for both axes of coordinates. The graph shall be normalized so that the magnitude of the Fourier transform is 100 % at zero spatial frequency.

The MODULATION TRANSFER FUNCTION shall as a minimum extend to the spatial frequency for which the magnitude of Fourier transformation falls to 10 %.

NOTE 2 Generally, the MODULATION TRANSFER FUNCTION below 10 % is of little importance for practical applications.

The one-dimensional MODULATION TRANSFER FUNCTIONS of the width and the length of a FOCAL SPOT shall be presented, together with the NOMINAL FOCAL SPOT VALUE in accordance with Clause 7.

NOTE 3 If the FOCAL SPOT MODULATION TRANSFER FUNCTION needs to be applied in any other plane, defined by " m " and " n " (Figure 4), then the frequency axis is scaled by the factor $(m+n)/n$, in order to take into account the effect of the magnification $(m+n)/m$, and of the enlargement n/m .

8.3 Statement of compliance

If compliance with this document for the presentation of a pair of MODULATION TRANSFER FUNCTIONS is to be stated, this shall be done in the following manner:

MODULATION TRANSFER FUNCTION for a NOMINAL FOCAL SPOT VALUE of 0,6 in accordance with IEC 60336:2020.

The following shall be stated in addition, if appropriate:	Subclause
REFERENCE AXIS	4.3
LOADING FACTORS	6.2.3
Special arrangements	6.2.4
Description of the longitudinal axis of the X-RAY TUBE ASSEMBLY	4.2
Direction of evaluation for the width of distorted FOCAL SPOTS	4.6

9 Alternative measurement methods for determining NOMINAL FOCAL SPOT VALUES

It is understood that those claiming compliance according to 7.4 or 7.5 may employ measurement methods other than the method specified in this document. This is permissible provided the alternative measurement method is correlated to the standard measurement method herein described.

This correlation shall demonstrate that NOMINAL FOCAL SPOT VALUES obtained by the alternative measurement method will not render NOMINAL FOCAL SPOT VALUES smaller than those obtained by the standard measurement method.

Annex A (informative)

Alignment to the REFERENCE AXIS

Figure A.1 gives an overview of the different axes and directions for a FOCAL SPOT measurement.

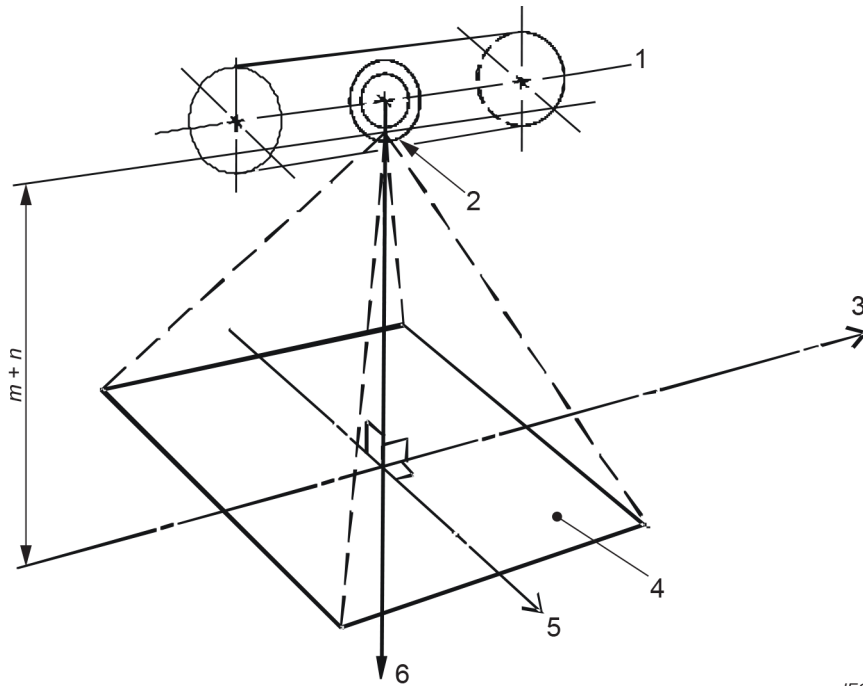

IEC

Key

- 1 longitudinal axis of the X-RAY TUBE ASSEMBLY
- 2 FOCAL SPOT
- 3 direction of evaluation for the FOCAL SPOT length
- 4 IMAGE RECEPTION PLANE
- 5 direction of evaluation for the FOCAL SPOT width
- 6 REFERENCE AXIS

Figure A.1 – REFERENCE AXIS and directions of evaluation

The values of the characteristics of a FOCAL SPOT, obtained by measurement and determination in accordance with the present document, are susceptible to a number of errors which are difficult to avoid or to compensate for without expensive test instrumentation and test procedures. So, generally, results should be considered qualitative only, unless all requirements of this document are met.

One of the factors which relatively strongly influences the results is the geometric alignment of the imaging diaphragm to the centre of the EFFECTIVE FOCAL SPOT. The shape and dimensions of the FOCAL SPOT over the RADIATION FIELD depend strongly on the direction of the PROJECTION of the FOCAL SPOT; see graphical representation in Figure A.2. Statements in accordance with this document refer only to the PROJECTION in the REFERENCE DIRECTION (marked "EFFECTIVE FOCAL SPOT" in Figure A.2).

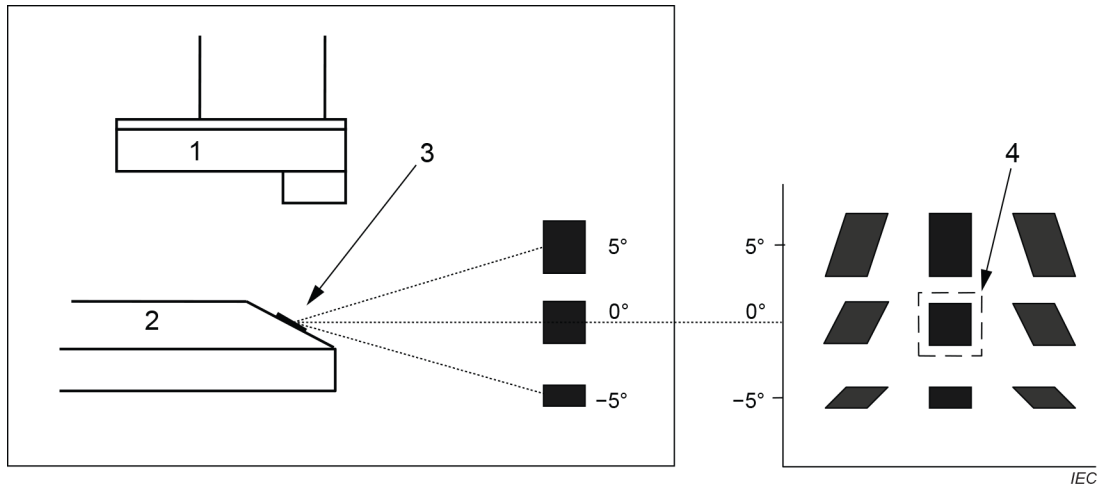

Key

- 1 CATHODE
- 2 ANODE
- 3 ACTUAL FOCAL SPOT
- 4 EFFECTIVE FOCAL SPOT for the statement according to this document

Figure A.2 – PROJECTION of the ACTUAL FOCAL SPOT on the IMAGE RECEPTION PLANE

Annex B (informative)

FOCAL SPOT STAR RADIOGRAM

B.1 Overview

Annex B deals with the production of FOCAL SPOT STAR RADIOGRAMS as used for the determination of the STAR PATTERN RESOLUTION LIMIT and BLOOMING VALUE of FOCAL SPOTS in accordance with Annex C and Annex D respectively.

NOTE In IEC 60336:2005, Clause 10 on FOCAL SPOT STAR RADIOGRAMS is a normative clause. In this document, this clause is no longer normative, but for historical reference, the content has been moved to this informative Annex B. No attempts have been made to update this method for digital techniques as introduced in this document; it is left to the user to implement any such changes.

B.2 Test EQUIPMENT

B.2.1 STAR PATTERN CAMERA

FOCAL SPOT STAR RADIOGRAMS are obtained by means of a STAR PATTERN CAMERA containing a test pattern, which consists of an array of alternating high and low absorbing wedges. The high absorbing wedges are made of lead or an equivalently absorbing material and have a thickness of 0,03 mm to 0,05 mm.

All wedges have a vertex angle Θ equal to or less than 0,035 rad (approximately 2°). The active area of the test pattern covers 2π rad and has a diameter of at least 45 mm. The essential dimensions of the test pattern and its basic structure are given in Figure B.1.

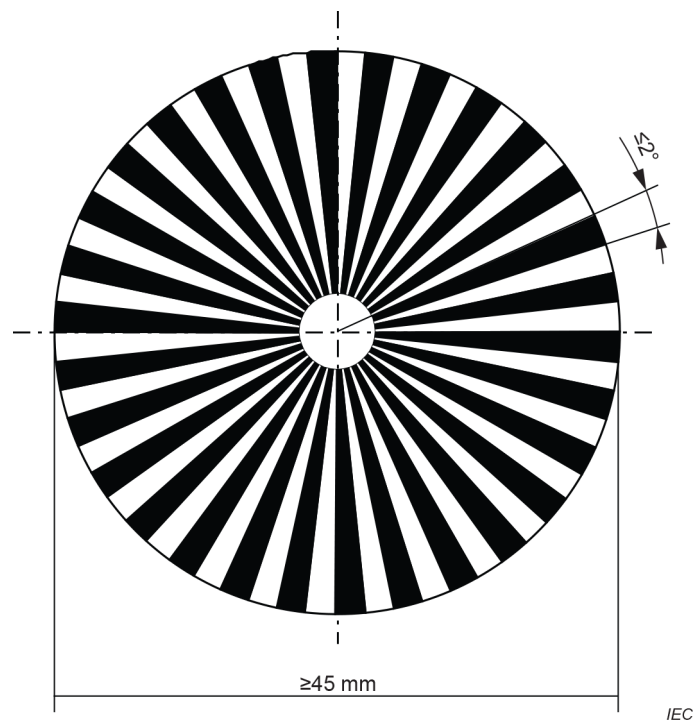

Figure B.1 – Essential dimensions of the star test pattern

B.2.2 RADIOGRAPHIC FILM

FOCAL SPOT STAR RADIOGRAMS are made using fine-grain RADIOGRAPHIC FILM without INTENSIFYING SCREENS.

B.2.3 Position of the STAR PATTERN CAMERA normal to the REFERENCE AXIS

The STAR PATTERN CAMERA is positioned in such a way that the distance from its centre to the REFERENCE AXIS is within 0,2 mm per 100 mm of m (as indicated in Figure B.2).

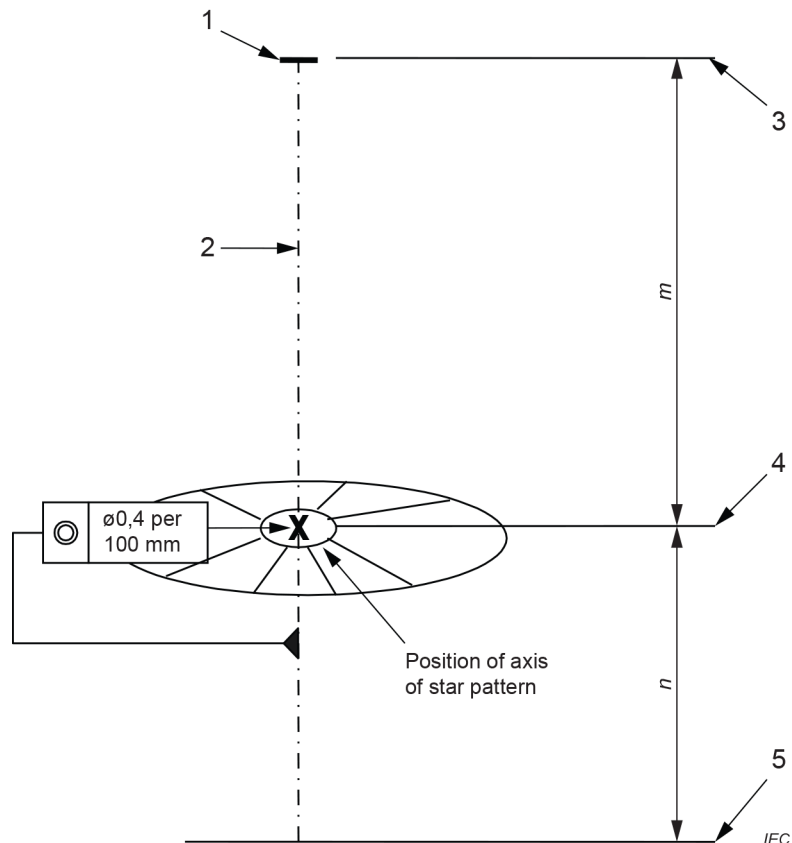

Key

- 1 EFFECTIVE FOCAL SPOT
- 2 REFERENCE AXIS
- 3 REFERENCE PLANE
- 4 incident face of the star pattern
- 5 IMAGE RECEPTION PLANE

NOTE Magnification = $(n + m)/m$

Figure B.2 – Alignment of the STAR PATTERN CAMERA

B.2.4 Position of the STAR PATTERN CAMERA in REFERENCE DIRECTION

The incident face of the test pattern is placed at a distance from the EFFECTIVE FOCAL SPOT allowing a magnification M' such that the dimensions Z_W and Z_L (see Figure C.1) measured in accordance with Clause C.2 will be more than or, where not practicable, as near as possible to one-third of the diameter of the image of the test pattern, but not less than 25 mm (see also B.2.6).

B.2.5 Alignment of the STAR PATTERN CAMERA

The incident face of the test pattern is placed normal within $\pm 2^\circ$ to the REFERENCE DIRECTION.

B.2.6 Position of the RADIOGRAPHIC FILM

The RADIOGRAPHIC FILM is placed normal to the REFERENCE DIRECTION within $\pm 2^\circ$ at a distance from the incident face of the test pattern, which results in a magnification M' as determined from the expected STAR PATTERN RESOLUTION LIMIT R in accordance with the formula:

$$M' = R \times Z \times \theta$$

where

M' is the magnification to be used;

R is the expected STAR PATTERN RESOLUTION LIMIT in line pairs per millimetre;

Z is the dimension in millimetres on the RADIOGRAPHIC FILM of the outermost zone of minimal modulation in the direction Z_W or Z_L , as appropriate;

θ is the vertex angle of the absorbing wedges in radians.

B.2.7 Operating conditions

The FOCAL SPOT STAR RADIOGRAM is obtained under the operating conditions described in 6.2.

B.2.8 Production of the FOCAL SPOT STAR RADIOGRAM

The RADIOGRAPHIC FILM of the STAR PATTERN CAMERA is exposed as described in 6.3.3 of IEC 60336:2005 (fourth edition).

Annex C (informative)

STAR PATTERN RESOLUTION LIMIT

C.1 Overview

Annex C deals with the determination of the STAR PATTERN RESOLUTION LIMIT.

The results of this method are useful to detect changes in the characteristics of a particular FOCAL SPOT over varying conditions of the X-RAY TUBE LOAD, or after extended use of the X-RAY TUBE.

NOTE 1 The method described gives unprecise results if the MODULATION TRANSFER FUNCTION does not contain a clearly defined minimum, as for example in cases where the radiant intensity has an approximately Gaussian distribution over the FOCAL SPOT.

NOTE 2 In IEC 60336:2005, Clause 11 on STAR PATTERN RESOLUTION LIMIT is a normative clause. In this document, this clause is no longer normative, but for historical reference, the content has been moved to this informative Annex C. No attempts have been made to update this method for digital techniques as introduced in this document; it is left to the user to implement any such changes.

C.2 Measurement

In FOCAL SPOT STAR RADIOGRAMS obtained in accordance with Annex B, the dimensions Z_W and Z_L of the outermost zones of minimal modulation are measured in the two directions of evaluation (see Clause 4 and Figure C.1).

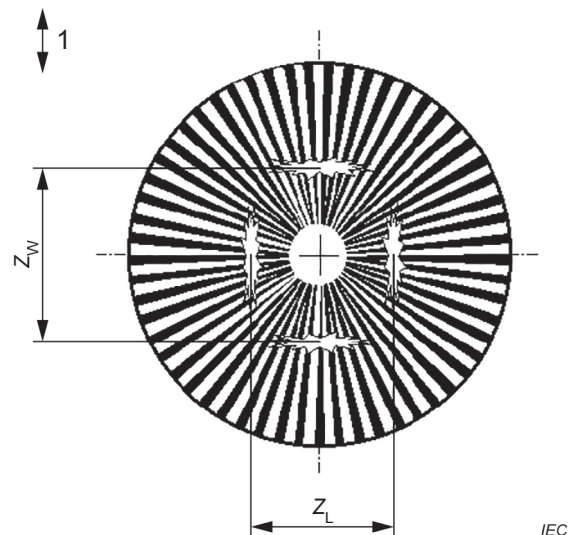

Key

1 direction of the longitudinal axis of the X-RAY TUBE ASSEMBLY

Figure C.1 – Illustration of the zones of minimum modulation

C.3 Determination of the STAR PATTERN RESOLUTION LIMIT

C.3.1 Determination of the magnification

The magnification M' used for the production of the FOCAL SPOT STAR RADIOGRAMS is determined with an accuracy within $\pm 3\%$.

C.3.2 STAR PATTERN RESOLUTION LIMIT for standard magnification

The STAR PATTERN RESOLUTION LIMITS, R_{WS} and R_{LS} , for the standard magnification given in Table C.1 are determined from the formulae:

$$R_{WS} = \{(M' - 1) / (Z_W \times \theta)\} \times \{M_S / (M_S - 1)\}$$

$$R_{LS} = \{(M' - 1) / (Z_L \times \theta)\} \times \{M_S / (M_S - 1)\}$$

where

R_{WS} and R_{LS} are the values for the two directions of evaluation in line pairs per millimetre;

M' is the magnification in accordance with B.2.6.;

M_S is the standard magnification according to Table C.1;

Z_W is the mean diameter of the outermost zone of minimal modulation measured in the direction parallel to the longitudinal axis of the X-RAY TUBE ASSEMBLY in millimetres;

Z_L is the mean diameter of the outermost zone of minimal modulation measured in the direction normal to the longitudinal axis of the X-RAY TUBE ASSEMBLY in millimetres;

θ is the vertex angle of the absorbing wedges in radians.

Table C.1 – Standard magnifications for STAR PATTERN RESOLUTION LIMIT

NOMINAL FOCAL SPOT VALUE f	Standard magnification M_S
$f < 0,6$	2
$0,6 \leq f$	1,3

C.3.3 STAR PATTERN RESOLUTION LIMIT for finite magnification

For the application of the STAR PATTERN RESOLUTION LIMIT at a particular magnification, the values R_{WS} and R_{LS} obtained in accordance with C.3.2, can be transformed in accordance with the formulae:

$$R_{WP} = R_{WS} \times \{(M_S - 1) / M_S\} \times \{M_P / (M_P - 1)\}$$

$$R_{LP} = R_{LS} \times \{(M_S - 1) / M_S\} \times \{M_P / (M_P - 1)\}$$

where

R_{WP} and R_{LP} are the values for the particular magnification;

R_{WS} and R_{LS} are the values obtained according to C.3.2;

M_S is the standard magnification;

M_P is the particular magnification.

C.3.4 Presentation of STAR PATTERN RESOLUTION LIMIT

The STAR PATTERN RESOLUTION LIMIT is given for the standard magnification in Table C.1.

Annex D (informative)

BLOOMING VALUE

D.1 Overview

Annex D deals with the determination of the BLOOMING VALUE of a FOCAL SPOT showing the dependence of the STAR PATTERN RESOLUTION LIMIT upon X-RAY TUBE LOAD.

NOTE In IEC 60336:2005, Clause 12 on BLOOMING VALUE is a normative clause. In this document, this clause is no longer normative, but for historical reference, the content has been moved to this informative Annex D. No attempts have been made to update this method for digital techniques as introduced in this document; it is left to the user to implement any such changes.

D.2 Determination of the BLOOMING VALUE

The BLOOMING VALUE is determined using pairs of STAR PATTERN RESOLUTION LIMITS established in accordance with Annex C, based upon FOCAL SPOT STAR RADIOGRAMS obtained with constant LOADING FACTORS in accordance with Table 2 and Table D.1 under otherwise the same operating conditions.

Table D.1 – LOADING FACTORS for the determination of the BLOOMING VALUE

	NOMINAL X-RAY TUBE VOLTAGE kV	Required X-RAY TUBE VOLTAGE	Exposure time	Required X-RAY TUBE power
RADIOGRAPHY other than COMPUTED TOMOGRAPHY	$U < 75$	NOMINAL X-RAY TUBE VOLTAGE	As appropriate for the detector applied.	100 % of the NOMINAL RADIOGRAPHIC ANODE INPUT POWER
	$75 \leq U \leq 150$	75 kV		100 % of the NOMINAL CT ANODE INPUT POWER
COMPUTED TOMOGRAPHY		120 kV		

The BLOOMING VALUE, B , results from the following formula:

$$B = R_{50} / R_{100}$$

where

R_{50} is the STAR PATTERN RESOLUTION LIMIT under operating conditions in accordance with Table 2;

R_{100} is the STAR PATTERN RESOLUTION LIMIT under operating conditions in accordance with Table D.1.

Annex E (informative)

Historical background

E.1 Overview

The purpose of Annex E is to describe the history behind IEC 60336 as it is today and to clarify the reasons behind some difficult parts.

E.2 First edition (1970)

The first edition was called *Measurement of the dimensions of focal spots of diagnostic X-ray tubes using a pinhole camera*, and was based on earlier ICRU recommendations [3], [4]³ and on national standards [5]. This first edition only described the pinhole measurements for determining the dimensions of FOCAL SPOTS. A magnifying glass with a magnification of 10 was to be used for direct film reading, as well as a 0,7 multiplying factor for the length.

E.3 Second edition (1982)

It was renamed *Characteristics of focal spots in diagnostic X-ray tube assemblies for medical use*. It added the slit method, basically because the determination of the dimensions of a FOCAL SPOT based on FOCAL SPOT PINHOLE RADIOGRAMS becomes difficult for NOMINAL FOCAL SPOT VALUES smaller than 0,3, as the results are affected by factors such as transmission through the shielding of the diaphragm and the need for repeated irradiation of the RADIOGRAPHIC FILM due to tube-LOADING considerations. The new method was applied over the entire range of usual NOMINAL FOCAL SPOT VALUES. The method avoided former uncertainties in determining the dimensions of FOCAL SPOTS and gave valuable results even in cases of distorted FOCAL SPOTS. Furthermore, determination of the imaging properties of the FOCAL SPOT in the form of a pair of one-dimensional MODULATION TRANSFER FUNCTIONS ("MTF") was also introduced.

Thus, the pinhole method was only used for showing the distribution and orientation of the FOCAL SPOT characteristics, and the slit method was to be used for determining the NOMINAL FOCAL SPOT VALUES and the MTF.

In addition, a third method was described for use in the field (FOCAL SPOT STAR RADIOGRAMS). The production of FOCAL SPOT STAR RADIOGRAMS had been standardized because of their usefulness in making a simple assessment of the imaging properties of a system under field conditions by establishing the STAR PATTERN RESOLUTION LIMIT under those conditions (assuming the FOCAL SPOT has such a characteristic).

The added nominal values (0,1; 0,15; 0,2) did not use the factor of 0,7; see Clause E.4.

E.4 Third edition (1993)

It was again renamed, to *X-ray tube assemblies for medical diagnosis – Characteristics of focal spots*. No other changes, except that the support for CT (called "special application") and the nominal value 0,25 were added. The added special application FOCAL SPOTS did not incorporate the 0,7 factor.

³ Numbers in square brackets refer to the Bibliography.

Factor 0,7 and asymmetrical ranges

Two issues in the standard have caused a lot of misunderstanding and discussion:

- the multiplying factor of 0,7 for the length;
- the concept of the nominal value with non-symmetrical ranges (e.g. the NOMINAL FOCAL SPOT VALUE 0,8 allows sizes from 0,8 mm to 1,2 mm).

Both of them have been hard to understand. The only way to explain them is to show the LINE SPREAD FUNCTIONS ("LSF") for some typical FOCAL SPOTS.

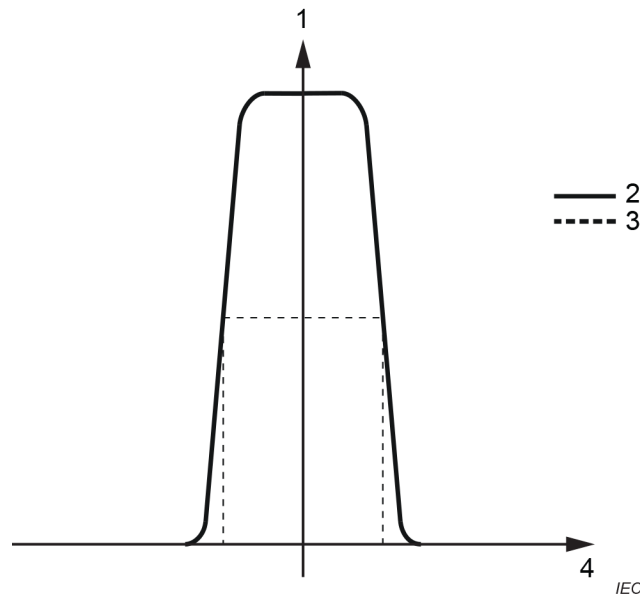

Key

- 1 X-ray intensity
- 2 width
- 3 length
- 4 dimensions

NOTE Length and width have the same shape.

Figure E.1 – LSFs for a typical X-RAY TUBE with small FOCAL SPOT (< 0,3 mm)

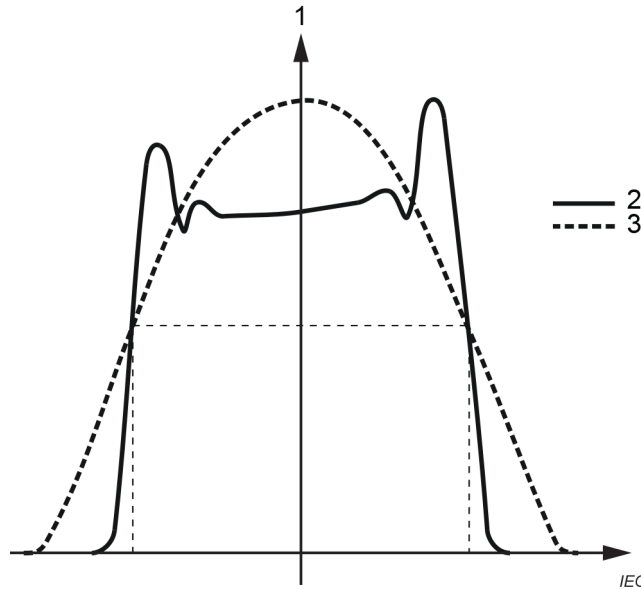

Key

- 1 X-ray intensity
- 2 width
- 3 length

Figure E.2 – LSFs for a typical X-RAY TUBE with large FOCAL SPOT ($\geq 0,3$ mm)

As seen, the slope of the edges of the LSFs varies. The natural reading of the size is obviously at full width half maximum (FWHM), which is at 50 % of the peak level. But since the technology of the 1950s and 1960s only allowed for film reading with a magnifying glass, the reading obtained was corresponding to something like 10 % to 20 % on the LSF. Since the measured value then, as seen in Figure E.1 and Figure E.2, will be larger, this basically explains the reason for the ranges not being symmetrical.

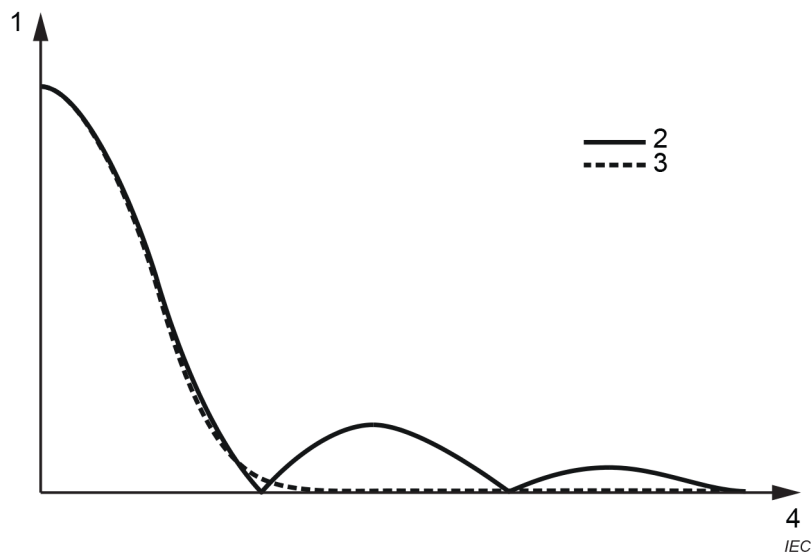

Key

- 1 MTF
- 2 width
- 3 length
- 4 spatial frequency

Figure E.3 – Corresponding MTFs for the LSFs in Figure E.2

The typical LSF for the length of a large FOCAL SPOT shows even more shallow edges, as shown in Figure E.2. This can also be seen as the length reading (at 10 % to 20 %) being typically 40 % larger than the width reading for a tube where the MTFs are approximately equal. Thus, to get a nominal value corresponding to the image quality obtained, the 0,7 factor was introduced. As seen in Figure E.3, the LSFs in Figure E.2 gives almost identical MTFs up to the first minimum, i.e. in practice they give the same image quality.

NOTE In the more refined RMS method [1] (root mean square), the width of the square shaped LSF, which gives the same image characteristics as any shaped LSF, is calculated. The RMS method can be used in future editions of IEC 60336. However, if more image characteristics beside the FOCAL SPOT value is of interest, more details are needed, such as MTF, different technique factors, etc. Also, with a change to the RMS or similar method, backward compatibility will be lost, so it is impractical.

E.5 Fourth edition (2005)

The main changes in the fourth edition of IEC 60336 are:

- a) practical specifications for tolerances, mainly for camera design and camera alignment;
- b) the line spread function is now used solely as basis for focal spot size determination; the density distribution used for determination of length and width is now determined using densitometric evaluation, replacing the visual evaluation;
- c) distorted (skewed) focal spots are no longer taken into account;
- d) the range of permissible values corresponding to the nominal focal spot value is replaced with a maximum permissible value only;
- e) allowing other methods of measurement, provided equivalence to the fourth edition of IEC 60336 is verified;

Concerning a): In the third edition of IEC 60336, some tolerances, particularly in the test arrangement for the FOCAL SPOT camera, were unnecessarily narrow, for example the angle between the REFERENCE AXIS and the axis of symmetry of the diaphragm was required to be within 0,001 rad, while no tolerance was specified for others such as the position of the diaphragm with respect to the REFERENCE AXIS. This is now avoided by means of an overall tolerance.

Concerning b): In the past, most MANUFACTURERS performed a densitometric analysis of the FOCAL SPOT SLIT RADIOGRAMS when determining the FOCAL SPOT sizes. This was the same procedure, the evaluation of the LINE SPREAD FUNCTION, which had to be performed to determine the MTF. To this extent, it was reasonable to standardise this procedure and to withdraw the method relying on visual evaluation. Hence, determination of both MTF and FOCAL SPOT dimensions are now based on measurements from the LINE SPREAD FUNCTION based on the same FOCAL SPOT SLIT RADIOGRAM.

Concerning c): With better fabrication and development methods of X-RAY TUBES, the occurrence of distorted FOCAL SPOTS has been greatly reduced. Additionally, FOCAL SPOT dimension measurements from FOCAL SPOT SLIT RADIOGRAMS are not as sensitive to FOCAL SPOT distortion as FOCAL SPOT PINHOLE RADIOGRAMS. Therefore, the clause concerning this was eliminated.

Concerning e): There is a large number of measuring EQUIPMENT in the market that use for example a CCD camera instead of RADIOGRAPHIC FILM in order to determine FOCAL SPOT characteristics. These methods are increasingly used by MANUFACTURERS for routine testing and Annex B gives recommendations for those cases. Obviously, MANUFACTURERS also intend to use this measuring EQUIPMENT to determine the FOCAL SPOT. Provided the test results can be verified to be identical to the standardised method using RADIOGRAPHIC FILM, the fourth edition of IEC 60336 allows those methods. The same applies to visually evaluated measurements using a magnifying glass in the previous editions of IEC 60336.

The fourth edition of IEC 60336 does not require the statement of all characteristics as listed in Table E.1 The information to be provided with an X-RAY TUBE ASSEMBLY is the subject of IEC 60601-2-28 [6].

In the third edition of IEC 60336, the method of characterising the FOCAL SPOT by means of the RMS value was given in a note. This method has not been widely accepted. However, following the omission of the mandatory specification of the one dimensional MODULATION TRANSFER FUNCTION in IEC 60601-2-28 [6] and because of the advancement of digital radiographic acquisition systems, the RMS approach could gain in importance.

Table E.1 – Methods for evaluation of specific aspects characterising the FOCAL SPOT

Information obtained by means of	According to Clause (4 th ed.)	About	According to Clause (4 th ed.)	Used for evaluating compliance with requirements on
Pair of FOCAL SPOT SLIT RADIOGRAMS	6	Dimensions	8	Specified NOMINAL FOCAL SPOT VALUE
		Imaging properties	9	Specified pair of one-dimensional MODULATION TRANSFER FUNCTIONS
FOCAL SPOT PINHOLE RADIOGRAM	6	Orientation		
		Radiation intensity distribution		
		Symmetry		
FOCAL SPOT STAR RADIOGRAM ^a	10	STAR PATTERN RESOLUTION LIMIT	11	STAR PATTERN RESOLUTION LIMIT
		BLOOMING VALUE	12	BLOOMING VALUE
		Modification of FOCAL SPOT properties over the life time		

^a The distribution of radiant intensity over a FOCAL SPOT does not always provide a point where the MODULATION TRANSFER FUNCTION will reach the spatial frequency axis. In this case, the method by means of a FOCAL SPOT STAR RADIOGRAM is not applicable.

E.6 Fifth edition (2020)

E.6.1 Overview

The main changes in the fifth edition of IEC 60336 are:

- a) introduction of digital detectors and discretization errors;
- b) fewer normative requirements;
- c) support for both SLIT CAMERA and PINHOLE CAMERA;
- d) reintroduction of distorted (skewed) FOCAL SPOT;
- e) keeping of STAR PATTERNS and BLOOMING VALUE as informative;

Technical details about items a) to e) are given in E.6.2 below.

E.6.2 Fifth edition technical details

a) Digital detectors and discretization errors

In the fourth edition, the characteristics of FOCAL SPOTS are analysed with RADIOGRAPHIC FILM as the receptor. As RADIOGRAPHIC FILM is hardly current praxis anymore, leading to many operational difficulties, and as high-quality digital detectors are readily available today, the

fifth edition applies digital detectors for the analysis of the FOCAL SPOT characteristics. The new defined term "DIGITAL FOCAL SPOT DETECTOR" designates such digital detectors. Both a 1-D detector (also called "line detector") and a 2-D detector may be applied. Such detectors have many inherent advantages over film including: greater X-ray sensitivity; linear response to X-ray exposure; no inaccuracies due to film scanning; no chemical process sensitivity; and no production of chemical or hazardous waste. The task of image analysis is further facilitated by digital signal- and image processing, such as noise-suppression, signal- interpolation, alignment, de-biasing, and base-line adjustment. Discretization errors are inherent to digital detectors and the subsequent signal processing. These errors will lead to LINE SPREAD FUNCTION widths which are larger than in the ideal case. In the document, notes recommend good practices for minimizing these errors. These good practices are thus not mandatory, as MANUFACTURERS should be allowed to apply different choices in view of their particular needs. The result might be, though, that the LINE SPREAD FUNCTION width is unnecessarily large. This could lead to a too large nominal FOCAL SPOT value. It is left to the MANUFACTURER's judgment to accept such larger LINE SPREAD FUNCTION widths.

In order to analyse the effect of the discretization, the 15 % width of the LINE SPREAD FUNCTION has been calculated for the typical LINE SPREAD FUNCTION for width (Figure 7), which is worst case for the effects of discretization, as a function of:

- the number of pixels over the 15 % width (NPW),
- the alignment of the pixel-grid with the LINE SPREAD FUNCTION,
- the number of levels in the maximum signal (NLS), and
- the signal-to-noise ratio (SNR).

The percentage error of the true width as a function of NPW is given in Figure E.4. Practical values are chosen for NLS and SNR: NLS = 200 (obtained with 8 bits dynamic range), and SNR = 200. The alignment of the pixel-grid has been varied in steps of 10 % of the pixel-width, so per number of pixels NPW, 10 data-points result. Linear interpolation for finding the 15 % level has been applied.

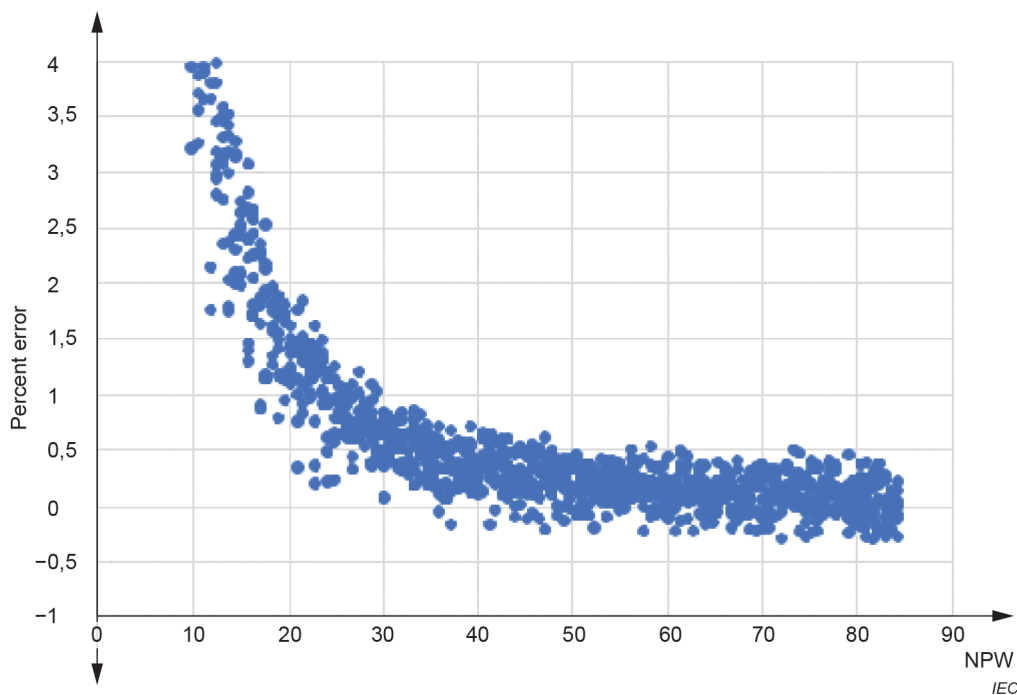

Figure E.4 – Percentage error of 15 % width

Conclusion: With practical digital detectors, and with the number of pixels (NPW) of 30 or more, the error due to discretization will be on the order of 1 %. If the number of pixels is relatively small, for example 15, the error can be up to 3 %. These findings are under the provision that

linear interpolation is applied; without linear interpolation, the percentage error is roughly twice as large.

b) Fewer normative requirements

As indicated in a) above, notes recommend good practices for minimizing errors. If the recommendations are not followed, chances are that the FOCAL SPOT size will be larger than necessary. However, the MANUFACTURER is free to adapt for his particular needs. The only normative requirements in this document are those which block the MANUFACTURER from determining a too-small FOCAL SPOT, for example the requirement in 6.3.1 on the spatial range of the FOCAL SPOT SLIT RADIOGRAM: "The spatial range of the FOCAL SPOT SLIT RADIOGRAM shall be such that further extension of the spatial range does not significantly change the result for the 15 % width."

Similarly, to accommodate the manufacture, the MANUFACTURER is given freedom to choose the enlargement E . In the fourth edition, the value of E is prescribed per range of NOMINAL FOCAL SPOT VALUE. In the fifth edition, this is a recommendation only, while indicating that a larger enlargement helps reducing the detrimental effect of the finite dimension of the diaphragm. As an illustration, the percentage errors in Figure E.5 have been obtained with an enlargement of 3,3, i.e. with an enlargement within the recommended range of E for this range of NOMINAL FOCAL SPOT VALUES. If the enlargement would be chosen smaller, the percentage error would be larger.

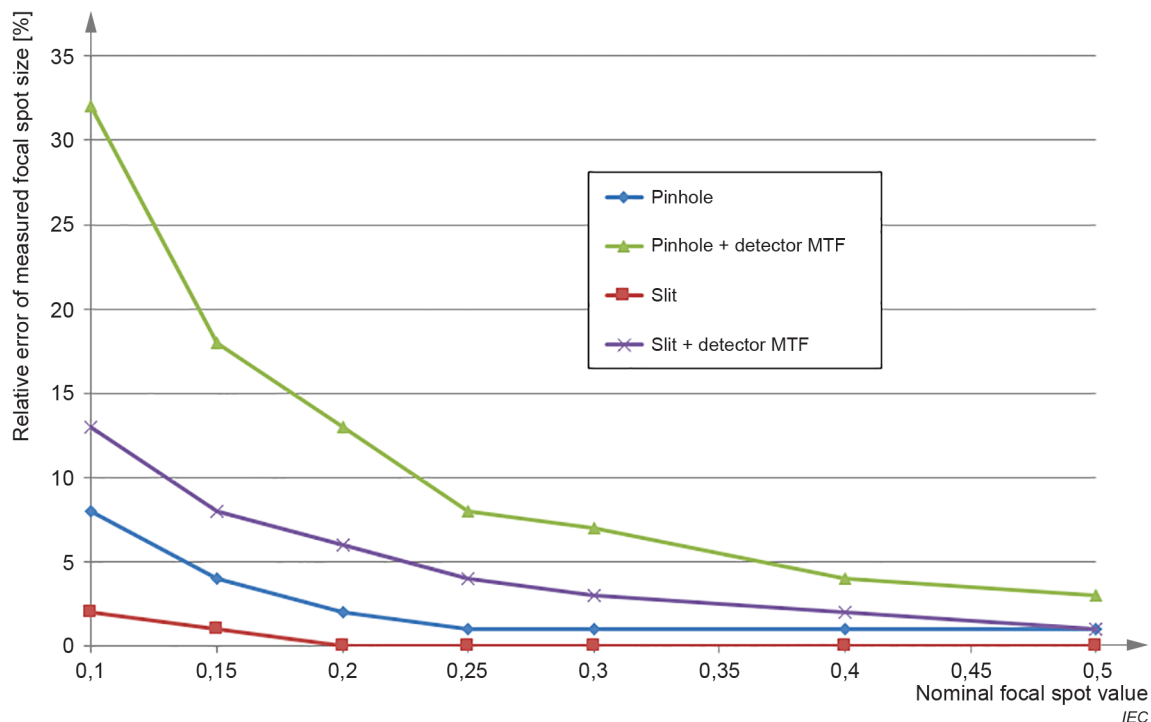

Figure E.5 – Percentage error of LINE SPREAD FUNCTION width at 15 %

d) Distorted FOCAL SPOTS

The new 4.6 re-instates the provision for "distorted FOCAL SPOTS", also called "skewed FOCAL SPOTS" as described in the third edition, 2.3.3.3, which provision had been removed in the fourth edition. The reasoning for the removal in the fourth edition as given in its Clause C.6: "With better fabrication and development methods of X-RAY TUBES, the occurrence of distorted FOCAL SPOTS has been greatly reduced" is in itself true. However, such distorted FOCAL SPOTS are very cost-effective to develop and to manufacture, so their use is still widespread. Further from experience and analysis, such distorted FOCAL SPOTS are not detrimental to image quality. The reasoning on image quality on the basis of MODULATION TRANSFER FUNCTIONS is identical to the

reasoning for the introduction of the "0,7 factor" for the determination of the NOMINAL FOCAL SPOT VALUE in the length-direction (Clause E.4, "Factor 0,7 and asymmetrical ranges"), which allows the LINE SPREAD FUNCTION in the length direction to be considerably larger than in the width-direction.

The rationale for the statement above that "such distorted FOCAL SPOTS are not detrimental to image quality" follows from Figure E.6 for a FOCAL SPOT with worst-case 20° skew. This shows that the MODULATION TRANSFER FUNCTION-quality of such distorted FOCAL SPOTS is insensitive for such other directions of evaluation as indicated in 4.6.

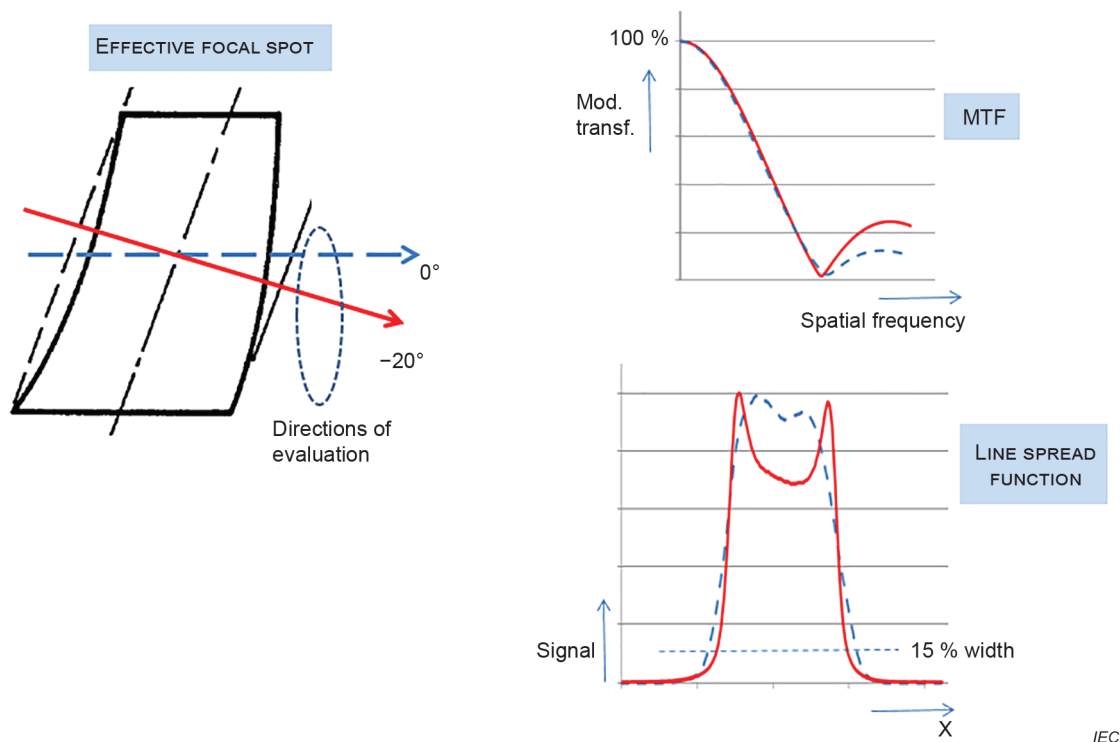

Figure E.6 – Influence of the direction of evaluation on MTF-quality and on LINE SPREAD FUNCTION width at 15 %

In Figure E.6, the LINE SPREAD FUNCTION in the standard, zero degrees direction (dotted lines) shows a larger width at 15 % than in the 20° direction. The corresponding MODULATION TRANSFER FUNCTION is however almost identical to the MODULATION TRANSFER FUNCTION of the LINE SPREAD FUNCTION in the direction for the smallest width, i.e. according to the skew – in this case under 20° (red lines). A repeat of the statement in Clause E.4 on MODULATION TRANSFER FUNCTIONS is here in order:

"Thus, to get a nominal value corresponding to the image quality obtained, the 0,7 factor was introduced. As seen in Figure E.3, the LSFs in Figure E.2 gives almost identical MTFs up to the first minimum, i.e. in practice they give the same image quality".

However, the provision for distorted FOCAL SPOTS in the third edition was open-ended in the sense that the maximum degrees of "distortion" was not quantified. Figure 4 in the third edition (reproduced in this document as Figure 1) indicates that up to 20° of "skew" was accepted. This is confirmed by the analyses above for 20° skew. To anchor such limitation, this fifth edition states explicitly:

"The direction of evaluation over the width of distorted FOCAL SPOTS shall not exceed $\pm 20^\circ$ from the normal evaluation direction".

In addition, it is stated, to safeguard traceability: "If a direction of evaluation other than the standard direction is used to determine the FOCAL SPOT width, then the value of this direction shall be stated as part of the statement of compliance with this document".

e) Star patterns and BLOOMING VALUE informative

As FOCAL SPOT STAR RADIOGRAMS and BLOOMING VALUE are of informative character, their application has been removed out of the normative text; they are now described in informative annexes. For these aspects, both RADIOGRAPHIC FILM and digital detectors can be used.

Bibliography

- [1] DOI, K. and ROSSMANN, K. Evaluation of focal spot distribution by RMS value and its effect on blood vessel imaging in angiography. *Proceedings of the Symposium on Application of Optical Instrumentation in Medicine III*, Vol. 47. Palos Verdes Estates, CA: Society of Photo-Optical Engineers, 1975: 207-213
- [2] DOI, K. et al. X-ray Tube Focal spot Sizes: Comprehensive Studies of Their Measurement and Effect of Measured Size in Angiography. *Radiation Physics*, July 1982, Volume 144, Number 2, p 383-393.
- [3] National Bureau of Standards Handbook 78, Report of the International Commission on Radiological Units and Measurements, (ICRU) 1959, U. S. Government Printing Office, Washington D. C., 1961
- [4] National Bureau of Standards Handbook 89, Methods of Evaluating Radiological Equipment and Materials: Recommendations of the ICRU, U.S. Government Printing Office, Washington, DC, 1962
- [5] DIN 6823, Roentgenroehren, Ermittlung der Brennfleckgroesse, Beuth-Verlag, Berlin, 1968
- [6] IEC 60601-2-28:2017, *Medical electrical equipment – Part 2-28: Particular requirements for the basic safety and essential performance of X-ray tube assemblies for medical diagnosis*
- [7] EN 12543-2:2008, *Non-destructive testing – Characteristics of focal spots in industrial X-ray systems for use in non-destructive testing – Part 2: Pinhole camera radiographic method*
- [8] IEC 60336:2005, *Medical electrical equipment – X-ray tube assemblies for medical diagnosis – Characteristics of focal spots*

Index of defined terms

ACTUAL FOCAL SPOT.....	3.1
ADDITIONAL FILTRATION	IEC 60601-1-3:2008, 3.3
ANODE ANGLE	IEC TR 60788:2004, rm-22-07
ATTENUATION	IEC 60601-1-3:2008, 3.7
BLOOMING VALUE	3.2
COMPUTED TOMOGRAPHY	IEC TR 60788:2004, rm-41-20
DIGITAL FOCAL SPOT DETECTOR.....	3.3
EFFECTIVE FOCAL SPOT (FOCAL SPOT)	3.4
EQUIPMENT	IEC TR 60788:2004, NG.02.11
FOCAL SPOT PINHOLE RADIOGRAM	3.5
FOCAL SPOT SLIT RADIOGRAM.....	3.6
FOCAL SPOT STAR RADIOGRAM	3.7
IMAGE RECEPTION PLANE	IEC TR 60788:2004, rm-37-15
INTENSIFYING SCREEN	IEC TR 60788:2004, rm-32-38
IONIZING RADIATION	IEC 60601-1-3:2008, 3.29
LINE SPREAD FUNCTION	IEC TR 60788:2004, rm-73-01
LOADING	IEC 60613:2010, 3.8
LOADING FACTOR	IEC 60613:2010, 3.10
MANUFACTURER.....	IEC 60601-1:2005 and IEC 60601-1:2005/AMD1:2012, 3.55
MODULATION TRANSFER FUNCTION.....	IEC TR 60788:2004, rm-73-05
NOMINAL CT ANODE INPUT POWER.....	IEC 60613:2010, 3.16
NOMINAL FOCAL SPOT VALUE	3.8
NOMINAL RADIOGRAPHIC ANODE INPUT POWER	IEC 60613:2010, 3.15
NOMINAL X-RAY TUBE VOLTAGE	IEC 60613:2010, 3.2
NORMAL USE.....	IEC 60601-1:2005 and IEC 60601-1:2005/AMD1:2012, 3.71
PARTICLE ACCELERATOR.....	IEC TR 60788:2004, rm-23-01
PINHOLE CAMERA	3.9
PROJECTION	IEC TR 60788:2004, rm-32-61
RADIATION FIELD	IEC 60601-1-3:2008, 3.58
RADIATION SOURCE	IEC 60601-1-3:2008, 3.61
RADIOGRAM.....	IEC TR 60788:2004, rm-32-02
RADIOGRAPHIC FILM	IEC TR 60788:2004, rm-32-32
RADIOGRAPHIC RATINGS	IEC 60613:2010, 3.22
RADIOGRAPHY	IEC TR 60788:2004, rm-41-06
REFERENCE AXIS.....	3.10
REFERENCE DIRECTION.....	3.11
REFERENCE PLANE	3.12
SLIT CAMERA	3.13
STAR PATTERN CAMERA	3.14
STAR PATTERN RESOLUTION LIMIT	3.15
STRAY RADIATION.....	IEC 60601-1-3:2008, 3.75
TARGET.....	3.16

IS 18443 : 2024

X-RAY EQUIPMENT	IEC 60601-1-3:2008, 3.78
X-RAY TUBE.....	IEC 60601-1-3:2008, 3.83
X-RAY TUBE ASSEMBLY	IEC 60601-1-3:2008, 3.84
X-RAY TUBE HOUSING	IEC 60601-1-3:2008, 3.86
X-RAY TUBE LOAD	IEC 60613:2010, 3.9
X-RAY TUBE VOLTAGE.....	IEC TR 60788:2004, rm-36-02

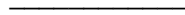

INTERNATIONAL ELECTROTECHNICAL COMMISSION
 COMMISSION INTERNATIONALE D'ÉLECTROTECHNIQUE INTERNATIONALE

IEC 60336
 Edition 5.0 2020-12

**Medical electrical equipment – X-ray tube
 assemblies for medical diagnosis –
 Focal spot dimensions and related
 characteristics**

IEC 60336
 Édition 5.0 2020-12

**Appareils électromédicaux – Gaines équipées
 pour diagnostic médical –
 Dimensions des foyers et caractéristiques
 connexes**

CORRIGENDUM 1

E.6.2 Fifth edition technical details

*Add, after the second paragraph of item
 b) in bold, the following new item c):*

c) SLIT CAMERA and PINHOLE CAMERA

As in the fourth edition, FOCAL SPOT SLIT RADIOGRAMS are used to determine THE NOMINAL FOCAL SPOT VALUES, and a FOCAL SPOT PINHOLE RADIOGRAM is used for information about the intensity distribution of the FOCAL SPOT.

E.6.2 Informations techniques concernant la cinquième édition

*Ajouter, après le second alinéa de
 l'élément b) en gras, le nouvel élément c)
 suivant:*

c) CAMERA A FENTE et CAMERA A STENOPE

Tout comme dans la quatrième édition, les RADIOGRAMMES A FENTE sont utilisés pour déterminer les VALEURS NOMINALES DU FOYER et un RADIOGRAMME A STENOPE est utilisé pour s'informer de la répartition d'intensité d'un FOYER.

As it is mathematically straight forward to calculate exactly FOCAL SPOT SLIT RADIOGRAMS from a FOCAL SPOT PINHOLE RADIOGRAM, and as further just *one* FOCAL SPOT PINHOLE RADIOGRAM gives information on the FOCAL SPOT SLIT RADIOGRAMS in *both* directions, MANUFACTURERS may wish to apply a FOCAL SPOT PINHOLE RADIOGRAM for determining NOMINAL FOCAL SPOT VALUES. However, as the pinhole has a diameter of 30 μm , whereas the slit has a much smaller width of just 10 μm , the resulting FOCAL SPOT SLIT RADIOGRAMS are always broader than those obtained with a slit diaphragm. This effect is larger, the smaller the FOCAL SPOT. The effect of this broadening is depicted in Figure E.5, for NOMINAL FOCAL SPOT VALUES from 0,1 to 0,5. The difference is large for the smallest FOCAL SPOT of 0,1. However, the difference gets vanishingly small for larger FOCAL SPOTS.

Étant donné qu'il est facile de calculer mathématiquement et de manière exacte les RADIOGRAMMES A FENTE à partir d'un RADIOGRAMME A STENOPE et comme en outre, *un seul* RADIOGRAMME A STENOPE donne des informations sur les RADIOGRAMMES A FENTE dans les *deux* directions, les FABRICANTS peuvent souhaiter appliquer un RADIOGRAMME A STENOPE pour déterminer des VALEURS NOMINALES DU FOYER. Néanmoins, étant donné que le sténopé a un diamètre de 30 μm , alors que la fente a une largeur beaucoup plus étroite de juste 10 μm , les RADIOGRAMMES A FENTE qui en résultent sont toujours plus larges que ceux obtenus avec un diaphragme à fente. Plus le FOYER est petit, plus l'effet est important. L'effet de cet élargissement est décrit à la Figure E.5, pour les VALEURS NOMINALES DE FOYER situées entre 0,1 et 0,5. La différence est importante pour le FOYER le plus petit de 0,1. Néanmoins, la différence devient infime pour les FOYERS plus grands.

[*\(Continued from second cover\)*](#)

The Committee has reviewed the provisions of the following International Standards referred in this adopted standard and has decided that these are acceptable for use in conjunction with this standard:

<i>International Standard</i>	<i>Title</i>
IEC 60417	Graphical symbols for use on equipment
IEC 60613 : 2010	Electrical and loading characteristics of X-ray tube assemblies for medical diagnosis

This standard is a modified adoption as some of the Indian Standards cross-referred (Column 2) in the first table above are not identical to the referred (Column 1) International Standards.

Only the English language text of the International Standard has been retained while adopting it in this Indian Standard, and as such the page numbers given here are not the same as in the IEC standard.

For the purpose of deciding whether a particular requirement of this standard is complied with the final value, observed or calculated, expressing the result of a test or analysis shall be rounded off in accordance with IS 2 : 2022 'Rules for rounding off numerical values (*second revision*)'. The number of significant places retained in the rounded off value should be the same as that of the specified value in this standard.

Bureau of Indian Standards

BIS is a statutory institution established under the *Bureau of Indian Standards Act, 2016* to promote harmonious development of the activities of standardization, marking and quality certification of goods and attending to connected matters in the country.

Copyright

BIS has the copyright of all its publications. No part of these publications may be reproduced in any form without the prior permission in writing of BIS. This does not preclude the free use, in the course of implementing the standard, of necessary details, such as symbols and sizes, type or grade designations. Enquiries relating to copyright be addressed to the Head (Publication & Sales), BIS.

Review of Indian Standards

Amendments are issued to standards as the need arises on the basis of comments. Standards are also reviewed periodically; a standard along with amendments is reaffirmed when such review indicates that no changes are needed; if the review indicates that changes are needed, it is taken up for revision. Users of Indian Standards should ascertain that they are in possession of the latest amendments or edition by referring to the website-www.bis.gov.in or www.standardsbis.in.

This Indian Standard has been developed from Doc No.: MHD 15 (22659).

Amendments Issued Since Publication

Amend No.	Date of Issue	Text Affected

BUREAU OF INDIAN STANDARDS

Headquarters:

Manak Bhavan, 9 Bahadur Shah Zafar Marg, New Delhi 110002

Telephones: 2323 0131, 2323 3375, 2323 9402

Website: www.bis.gov.in

Regional Offices:

	Telephones
Central : 601/A, Konnectus Tower -1, 6 th Floor, DMRC Building, Bhavbhuti Marg, New Delhi 110002	{ 2323 7617
Eastern : 8 th Floor, Plot No 7/7 & 7/8, CP Block, Sector V, Salt Lake, Kolkata, West Bengal 700091	{ 2367 0012 2320 9474
Northern : Plot No. 4-A, Sector 27-B, Madhya Marg, Chandigarh 160019	{ 265 9930
Southern : C.I.T. Campus, IV Cross Road, Taramani, Chennai 600113	{ 2254 1442 2254 1216
Western : Manakalya, 4 th Floor, NTH Complex (W Sector), F-10, MIDC, Andheri (East), Mumbai 400093	{ 283 25838

Branches : AHMEDABAD, BENGALURU, BHOPAL, BHUBANESHWAR, CHANDIGARH, CHENNAI, COIMBATORE, DEHRADUN, DELHI, FARIDABAD, GHAZIABAD, GUWAHATI, HARYANA, HUBLI, HYDERABAD, JAIPUR, JAMMU & KASHMIR, JAMSHEDPUR, KOCHI, KOLKATA, LUCKNOW, MADURAI, MUMBAI, NAGPUR, NOIDA, PARWANOO, PATNA, PUNE, RAIPUR, RAJKOT, SURAT, VIJAYAWADA.