

भारतीय मानक
Indian Standard

IS 13972 : 2024

घरेलू सिलाई मशीनें — बॉबिन वाइन्डर
असेंबली — विशिष्टि
(पहला पुनरीक्षण)

Household Sewing Machines —
Bobbin Winder Assembly —
Specification
(First Revision)

ICS 61.080

© BIS 2024



भारतीय मानक ब्यूरो
BUREAU OF INDIAN STANDARDS
मानक भवन, 9 बहादुर शाह ज़फर मार्ग, नई दिल्ली -
110002

MANAK BHAVAN, 9 BAHADUR SHAH ZAFAR MARG
NEW DELHI - 110002

www.bis.gov.in www.standardsbis.in

November 2024

Price Group 5

FOREWORD

This Indian Standard (First Revision) was adopted by the Bureau of Indian Standards, after the draft finalized by the Sewing Machine Sectional Committee had been approved by the Mechanical Engineering Division Council.

This standard has been prepared to unify and rationalize the types and sizes of sewing machine components for manufacturing in economic quantities. Bobbin winder assembly is actuated by the contact diameter of the flywheel and the quality of stitching depends to a large extent on the efficiency of the assembly besides the other parameters.

This standard was first published in 1994. The present revision has been taken up with a view to incorporating the modifications found necessary as a result of experience gained on the use of this standard and amendments issued from time to time have also been incorporated. Also, in this revision, the standard has been brought into the latest style and format of Indian Standard, and references to Indian Standards, wherever applicable have been updated. The BIS certification marking clause has been modified to align with the revised *Bureau of Indian Standards Act, 2016*. In this revision, all the amendments have been incorporated.

For general requirements, IS 1610 'Household sewing machines — General requirements' shall be referred.

The composition of the Committee responsible for the formulation of this standard is given in [Annex C](#).

For the purpose of deciding whether a particular requirement of this standard is complied with, the final value, observed or calculated, expressing the result of a test or analysis, shall be rounded off in accordance with IS 2 : 2022 'Rules for rounding off numerical values (*second revision*)'. The number of significant places retained in the rounded off value should be the same as that of the specified value in this standard.

*Indian Standard***HOUSEHOLD SEWING MACHINES — BOBBIN WINDER
ASSEMBLY — SPECIFICATION***(First Revision)***1 SCOPE**

1.1 This standard specifies the requirements for bobbin winder assembly for sewing machines for household purposes.

1.2 It deals with bobbin winder assembly to be actuated by the contact diameter of the flywheel.

2 REFERENCES

The standards listed in [Annex A](#) contain provisions which through reference in this text, constitute provisions of this standard. At the time of publication, the editions indicated were valid. All standards are subject to revision, and parties to agreements based on this standard are encouraged to investigate the possibility of applying the most recent editions of these standards.

3 NOMENCLATURE

Nomenclature of the bobbin winder assembly shall be as indicated in [Fig. 1](#).

4 MATERIAL

4.1 Cast iron parts shall be manufactured from cast iron conforming to FG 150 of IS 210.

4.2 Steel parts shall be manufactured from any suitable steel, such as 20C8 or 40C8 of IS 1570 (Part 2/Sec 1).

5 HARDNESS

All the screws, springs used in the sub-assembly shall be given suitable treatment to ensure satisfactory function.

6 DIMENSIONS

The main dimension of bobbin winder assembly shall be as given in [Fig. 2](#).

7 TOLERANCES

7.1 The axial play between the outer diameter of bobbin spindle and its hole on bobbin winder frame shall not exceed 0.15 mm.

7.2 The play on the disconnecting lever at the contact face with bobbin shall not exceed 0.5 mm.

7.3 Provision for adjustment against wear on friction ring shall be made in the design.

8 LUBRICATION

8.1 Provision shall be made on the bobbin winder frame for oiling the bearing surface on bobbin spindle.

8.2 Provision for oiling the bearing for arm shaft with the arm shall also be made through belt guard casting.

9 WORKMANSHIP AND FINISH

9.1 The bobbin winder assembly shall be well-finished and all the parts shall be free from defects such as cracks, rust, burrs, sharp edges, scratches, blisters, manufacturing defects and inferior surface treatments.

9.2 Components of bobbin winder assembly shall have chrome nickel plated surface finish conforming to at least service grade no. 1 with designation Fe/Ni 10b Cr r of IS 1068.

9.3 The painted parts shall have good, smooth and glossy surface finish and shall be free from defects. The colour of the stoving enamel shall be as desired by the buyer. The design and colour of transfer shall be as desired by the buyer. Paint film finish and harness shall conform to IS 101 (Part 3/Sec 4) and IS 101 (Part 5/Sec 1) respectively.

9.4 The movement of the disconnecting lever and bobbin winder lever shall be smooth and no stickiness shall be felt at intermediate positions.

9.5 Rust preventive treatment shall be given to other hardware items and visible portion.

9.6 The screws shall be rigidly tightened.

9.7 The assembly shall be such that the thread winding shall stop automatically by disengagement of disconnecting lever when it is filled to desired capacity. In addition to the auto-trip system, adjusting screw type system may be provided.

9.8 There shall be no sticky feeling when the bobbin spindle is rotated for one revolution at a slow speed.

10 SAMPLING

10.1 Unless otherwise agreed between the manufacturer and the buyer the sampling plan as given in Annex B shall be followed.

10.2 For further information, reference may be made to IS 2500 (Part 1)/ISO 2859-1.

11 TESTS

11.1 The locking of the bobbing on bobbin spindle shall be ensured to avoid slippage.

11.2 The winding on bobbin shall automatically get tripped off when nearly 80 percent winding will be complete.

11.3 The rubber ring shall not slip over the bobbin pulley.

11.4 After engaging the bobbin on bobbin spindle, when the bobbin winder lever is pressed, the disconnecting lever shall fall freely in the gap between two washers of bobbin.

12 MARKING

The bobbin winder assembly may be marked with the source of manufacturer or trademark.

12.1 BIS Certification Marking

The product(s) conforming to the requirements of this standard may be certified as per the conformity assessment schemes under the provisions of the *Bureau of Indian Standards Act, 2016* and the Rules and Regulations framed thereunder, and the product(s) may be marked with the Standard Mark.

13 PACKING

13.1 Each bobbin winder assembly shall be given a suitable antirust coating and then individually wrapped in a suitable polyethylene bag.

13.2 The wrapped bobbin winder assembly shall be securely packed in card board carton in accordance with the best prevalent trade practice. Each carton shall bear the manufacturer's name or trade-mark, type and description of contents/quantity.

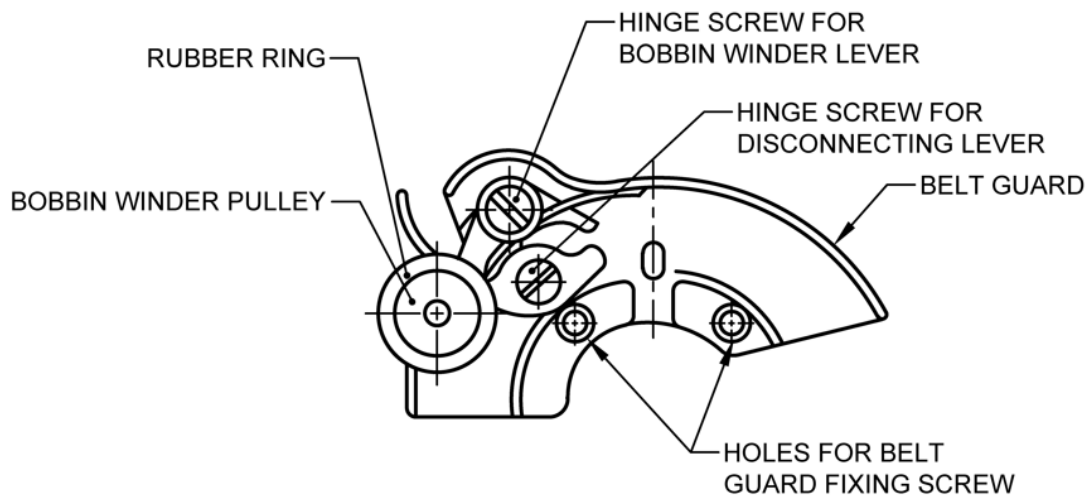

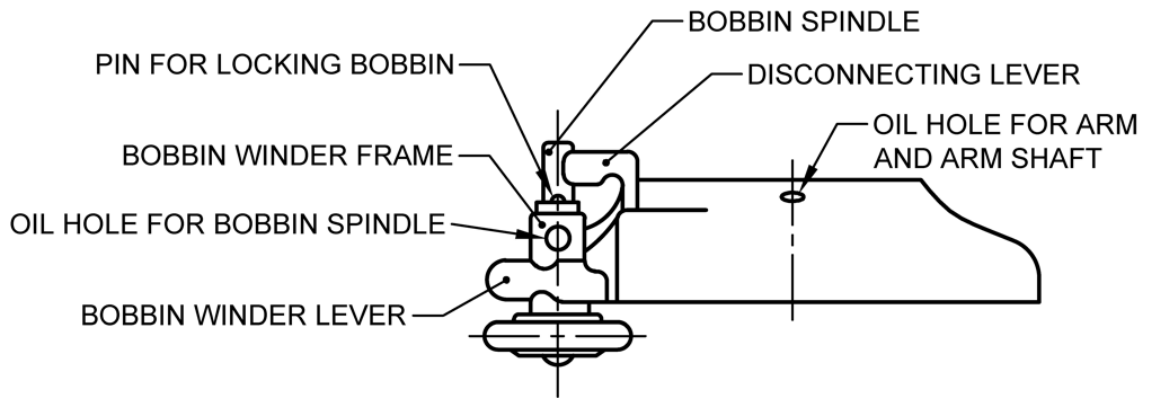
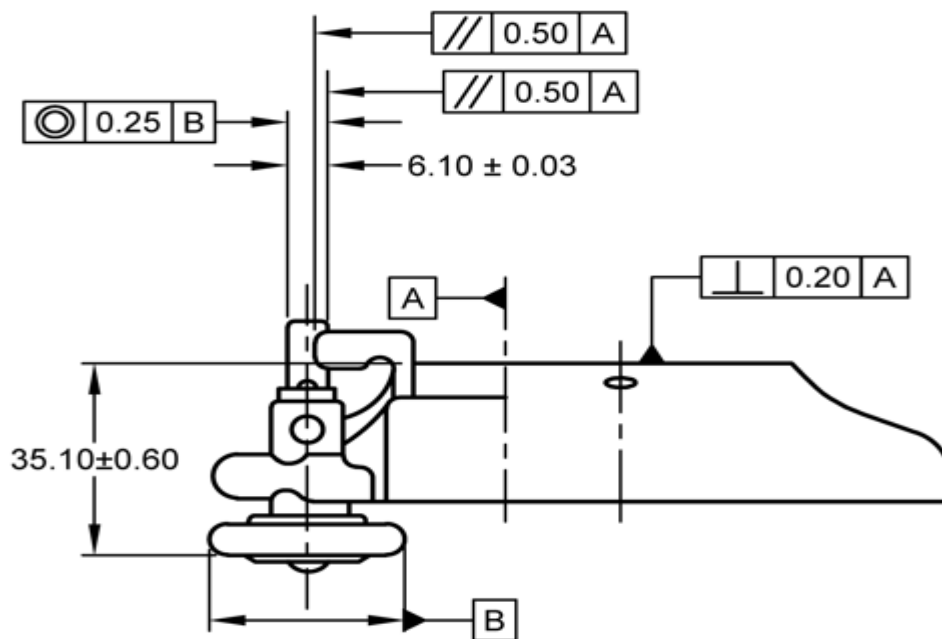
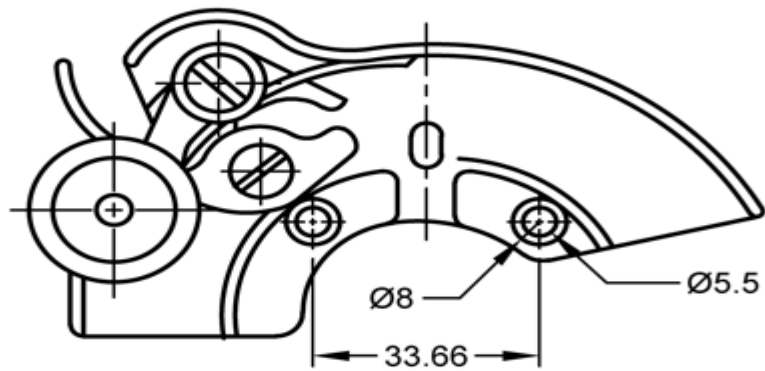

FIG. 1 NOMENCLATURE FOR BOBBIN WINDER ASSEMBLY



All dimensions in millimetres.

FIG. 2 DIMENSIONS FOR BOBBIN WINDER ASSEMBLY

ANNEX A

(Clause 2)

LIST OF REFERRED STANDARDS

<i>IS No.</i>	<i>Title</i>	<i>IS No.</i>	<i>Title</i>
IS 101	Method of sampling and test for paints, varnishes and related products	IS 1570 (Part 2/ Sec 1) : 1979	Schedule for wrought steels: Part 2 Carbon steels (unalloyed steel): Section 1 Wrought products (other than wire) with specified chemical composition and related properties (<i>first revision</i>)
(Part 3/Sec 4) : 1987	Test on paint film formation: Section 4 Finish (<i>third revision</i>)		
(Part 5/Sec 1) : 1988	Mechanical test for paint films: Section 1 Hardness test (<i>third revision</i>)	IS 2500 (Part 1) : 2000/ISO 2859-1 : 1999	Sampling procedures for inspection by attributes: Part 1 Sampling schemes indexed by acceptance quality limit (AQL) for lot-by-lot inspection (<i>third revision</i>)
IS 210 : 2009	Grey iron castings — Specification (<i>fifth revision</i>)		
IS 1068 : 1993	Electroplated coating of nickel plus chromium and copper plus nickel plus chromium — Specification (<i>third revision</i>)	IS 4905 : 2015/ ISO 24153 : 2009	Random sampling and randomization procedures (<i>first revision</i>)

To access Indian Standards click on the link below:

https://www.services.bis.gov.in/php/BIS_2.0/bisconnect/knownyourstandards/Indian_standards/isdetails/

ANNEX B

(Clause [10.1](#))

SCALE OF SAMPLING AND CRITERIA FOR CONFORMITY

B-1 SCALE OF SAMPLING**B-1.1 Lot**

In any consignment all the bobbin winders of same type and manufactured from the same material under essentially similar conditions of manufacture shall be grouped together to constitute a lot.

B-1.2 For ascertaining the conformity of the lot to the requirements of specification, tests shall be carried out for each lot separately. The number of bobbin winders to be selected at random for this purpose shall be in accordance with col (2) and col (3) of [Table 1](#).

B-1.3 If the bobbin winders are packed individually, in order to ensure the randomness of selection IS 4905/ISO 24153 shall be used.

B-1.4 If the bobbin winders are packed in different cartons, a suitable number of cartons (not less than

20 percent of the total in the lot subject to a minimum of 2) shall be chosen at random. From each of the cartons so chosen, an approximately equal number of bobbin winders shall be picked up from its different parts so as to obtain the required number of bobbin winders specified in col (3) of [Table 1](#).

B-2 NUMBER OF TESTS AND CRITERIA FOR CONFORMITY

B-2.1 The bobbin winders selected according to [B-1.2](#) and [B-1.3](#) or [B-1.4](#) shall be examined for dimensions (*see* [6](#)), tolerances (*see* [7](#)) workmanship and finish (*see* [9](#)) and other tasks (*see* [11](#)). If the number of bobbin winders failing to meet one or more of the requirements mentioned above is less than or equal to the permissible number of defectives given in col (4) of [Table 1](#), the lot shall be declared as conforming to the requirements of those characteristics.

Table 1 Scale of Sampling and Permissible Number of Defectives(Clauses [B-1.2](#), [B-1.4](#) and [B-2.1](#))

SI No.	No. of Bobbin Winders in the Lot <i>N</i>	For Dimensions Tolerances and Workmanship and Finish	
		Sample Size <i>n</i>	Permissible No. of Defectives ¹
(1)	(2)	(3)	(4)
i)	Upto 15	5	0
ii)	16 to 40	8	0
iii)	41 to 110	13	0
iv)	111 to 300	20	1
v)	301 to 500	32	1
vi)	501 to 800	50	2
vii)	801 to 1 300	80	3
viii)	1 301 and above	125	5

¹) This ensures that lots containing only half percent or less defective will be acceptable most of the time.

ANNEX C

(Foreword)

COMMITTEE COMPOSITION

Sewing Machines Sectional Committee, MED 29

<i>Organization</i>	<i>Representative(s)</i>
Research & Development Centre for Bicycle and Sewing Machines, Ludhiana	SHRI SANJEEV KATOCH (<i>Chairperson</i>)
Research & Development Centre for Bicycle and Sewing Machines, Ludhiana	SHRI PAPINDER SINGH SHRI VISHWAS MEHTA (<i>Alternate I</i>) SHRI MANPREET SINGH (<i>Alternate II</i>)
Brother International (India) Private Limited, Mumbai	SHRI MATHEW YOHANNAN
C R Auluck & Sons Private Limited, Ludhiana	SHRI SUNIL AULUCK SHRI KULJEET SINGH (<i>Alternate</i>)
Directorate General of Quality Assurance, New Delhi	SHRI R. V. JAIN
G D Rupal Industries, Ludhiana	SHRI GURMUKH SINGH
Gee Tech Hooks, Ludhiana	SHRI MANJEET SINGH
Geminy Industrial Enterprises Private Limited, Ludhiana	SHRI VINAY DUA SHRI B. C. PANDEY (<i>Alternate</i>)
Ludhiana Sewing Machine Association, Ludhiana	SHRI HARDEEP SINGH SHRI RAJVINDER (<i>Alternate</i>)
Makhan Sewing Machines, Ludhiana	SHRI DALBIR SINGH DHIMAN
Narindera and Company, Ludhiana	SHRI S. BALDEV SINGH SHRI HARINDER JIT SINGH (<i>Alternate</i>)
Navrang Manufacturing Corporation, Ludhiana	SHRI DINESH KAPILA SHRI SUDESH KAPILA (<i>Alternate</i>)
Northern India Textile Research Association, Ghaziabad	SHRI VIKAS SHARMA SHRI VIVEK AGARWAL (<i>Alternate</i>)
Novel Sewing Machine Technologies, Pune	SHRI BHARAT NARAYENDAS PARMAR SHRI ARJUN BHARAT PARMAR (<i>Alternate</i>)
ORAA International, Ludhiana	SHRI ASHISH GUPTA
Office of Development Commissioner (MSME), New Delhi	SHRI SUVANKAR SANTRA MS MAITREYEE TALAPATRA (<i>Alternate</i>)
Ranew Engineering (India) Private Limited, Ludhiana	SHRI SANJEEV KUMAR JAIN SHRI ABHILASH JAIN (<i>Alternate</i>)
Singer India Limited, New Delhi	SHRI PRASHANT AGGARWAL SHRI ATUL KUMAR SETH (<i>Alternate</i>)
Swan Mechanical Works, Ludhiana	SHRI AMARJEET SINGH
United Sewing Machines and Parts Manufacturing Association, Ludhiana	SHRI DALBIR SINGH DHIMAN
Usha International Limited, New Delhi	SHRI RUP LAL KANGLA SHRI PRANAY SRIWASTAV (<i>Alternate</i>)

<i>Organization</i>	<i>Representative(s)</i>
Uttam Sewing Machine Company (Private) Limited, Jalandhar	SHRI JAGDEEP RAI SHRI MANOHAR LAL (<i>Alternate</i>)
Virindra Engineering Works, Ludhiana	SHRI AMARPREET SINGH PANESAR SHRI SWARN SINGH (<i>Alternate</i>)
Voluntary Organisation in Interest of Consumer Education (VOICE), New Delhi	SHRI M. A. U. KHAN
BIS Directorate General	SHRI K. VENKATESWARA RAO, SCIENTIST 'F'/SENIOR DIRECTOR AND HEAD (MECHANICAL) [REPRESENTING DIRECTOR GENERAL (<i>Ex-officio</i>)]

Member Secretary
SHRI SHUBHAM TIWARI
SCIENTIST 'D'/JOINT DIRECTOR
(MECHANICAL), BIS

Bureau of Indian Standards

BIS is a statutory institution established under the *Bureau of Indian Standards Act, 2016* to promote harmonious development of the activities of standardization, marking and quality certification of goods and attending to connected matters in the country.

Copyright

BIS has the copyright of all its publications. No part of these publications may be reproduced in any form without the prior permission in writing of BIS. This does not preclude the free use, in the course of implementing the standard, of necessary details, such as symbols and sizes, type or grade designations. Enquiries relating to copyright be addressed to the Head (Publication & Sales), BIS.

Review of Indian Standards

Amendments are issued to standards as the need arises on the basis of comments. Standards are also reviewed periodically; a standard along with amendments is reaffirmed when such review indicates that no changes are needed; if the review indicates that changes are needed, it is taken up for revision. Users of Indian Standards should ascertain that they are in possession of the latest amendments or edition by referring to the website-www.bis.gov.in or www.standardsbis.in.

This Indian Standard has been developed from Doc No.: MED 29 (24192).

Amendments Issued Since Publication

Amend No.	Date of Issue	Text Affected

BUREAU OF INDIAN STANDARDS

Headquarters:

Manak Bhavan, 9 Bahadur Shah Zafar Marg, New Delhi 110002

Telephones: 2323 0131, 2323 3375, 2323 9402

Website: www.bis.gov.in

Regional Offices:

Central : 601/A, Konnectus Tower -1, 6th Floor,
DMRC Building, Bhavbhuti Marg, New
Delhi 110002

Telephones

{ 2323 7617

Eastern : 8th Floor, Plot No 7/7 & 7/8, CP Block, Sector V,
Salt Lake, Kolkata, West Bengal 700091

{ 2367 0012
{ 2320 9474

Northern : Plot No. 4-A, Sector 27-B, Madhya Marg,
Chandigarh 160019

{ 265 9930

Southern : C.I.T. Campus, IV Cross Road, Taramani, Chennai 600113

{ 2254 1442
{ 2254 1216

Western : 5th Floor/MTNL CETTM, Technology Street, Hiranandani Gardens,
Powai, Mumbai 400076

{ 2570 0030
{ 2570 2715

Branches : AHMEDABAD, BENGALURU, BHOPAL, BHUBANESHWAR, CHANDIGARH, CHENNAI, COIMBATORE, DEHRADUN, DELHI, FARIDABAD, GHAZIABAD, GUWAHATI, HARYANA (CHANDIGARH), HUBLI, HYDERABAD, JAIPUR, JAMMU, JAMSHEDPUR, KOCHI, KOLKATA, LUCKNOW, MADURAI, MUMBAI, NAGPUR, NOIDA, PARWANOO, PATNA, PUNE, RAIPUR, RAJKOT, SURAT, VIJAYAWADA.