

वायरलाइन हीरक क्रोड वेधन उपस्कर —
पद्धति ए
भाग 1 मीटरी इकाइयाँ
(पहला पुनरीक्षण)

Wireline Diamond Core Drilling
Equipment — System A
Part 1 Metric Units
(First Revision)

ICS 73.100.30

© BIS 2024



भारतीय मानक ब्यूरो
BUREAU OF INDIAN STANDARDS
मानक भवन, 9 बहादुर शाह ज़फर मार्ग, नई दिल्ली - 110002
MANAK BHAVAN, 9 BAHADUR SHAH ZAFAR MARG
NEW DELHI - 110002
www.bis.gov.in www.standardsbis.in

FOREWORD

This Indian Standard (Part 1) (First Revision) was adopted by the Bureau of Indian Standards, after the draft finalized by the Diamond Core and Waterwell Drilling Sectional Committee had been approved by the Mechanical Engineering Division Council.

This standard was first published in 2004. This standard is being revised again to keep pace with the latest technological developments and international practices. Also, in this revision, the standard has been brought into the latest style and format of Indian Standards, and references of Indian Standards, wherever applicable have been updated. The following major modifications have been incorporated in this revision of the standard:

- a) Mechanical properties have been revised;
- b) Eccentricity limit has been revised; and
- c) Straightness has been modified.

In the preparation of this standard, considerable assistance has been derived from the following standard:

ISO 10097-1 : 1999 Wireline diamond core drilling equipment — System A: Part 1 Metric units

The composition of the Committee responsible for the formulation of this standard is given in [Annex B](#).

For the purpose of deciding whether a particular requirement of this standard is complied with, the final value, observed or calculated, expressing the result of a test or analysis, shall be rounded off in accordance with IS 2 : 2022 'Rules for rounding off numerical values (*second revision*)'. The number of significant places retained in the rounded off value should be the same as that of the specified value in this standard.

Indian Standard

WIRELINE DIAMOND CORE DRILLING EQUIPMENT —
SYSTEM A

PART 1 METRIC UNITS

(First Revision)

1 SCOPE

This standard specifies the nomenclature and the leading dimensions necessary for the interchangeability of the following wireline drilling equipment for drilling holes 48 mm to 96 mm in diameter, yielding cores of 27 mm to 63 mm in diameter.

The equipment is illustrated in [Fig. 1](#) and comprises the following:

- a) Core bit;
- b) Reaming shell;
- c) Core lifter;
- d) Core lifter case;
- e) Outer tube;
- f) Inner tube; and
- g) Drill rod (smooth pipe only).

2 REFERENCES

The standard given below contain provisions which, through reference in this text, constitute provision of this standard. At the time of publication, the editions indicated were valid. All standards are subject to revision, and parties to agreements based on this standard are encouraged to investigate the possibility of applying the most recent editions of the standards:

<i>IS No./Other Standards</i>	<i>Title</i>
IS 9439 : 2022	Glossary of terms used in water well drilling technology (<i>first revision</i>)

*IS No./Other Standards**Title*

IS/ISO 18758-1 : 2018	Mining and earth-moving machinery — Rock drill rigs and rock reinforcement rigs: Part 1 Vocabulary
ISO 3551-1 : 1992	Rotary core diamond drilling equipment — System A: Part 1 Metric units

3 TERMINOLOGY

For the purpose of this standard the terminologies given in IS 9439 and IS/ISO 18758-1 shall apply.

4 DESIGNATION

Items made in accordance with this part shall be designated by the identification letters WL and hole dimensions *A*, *B*, *N*, and *H*.

Example:

Core bit for wireline drilling hole *B* dimensions: WLB core bit.

5 MATERIALS

Materials used in the manufacture of the wireline drilling equipment specified in this standard shall have the minimum mechanical properties as specified in [Table 1](#).

Table 1 Mechanical Properties

(Clause 5)

Sl No.	Component	Minimum Tensile Strength, y N/mm ² (MPa)	Minimum Yield Stress, Re, N/mm ² (MPa)	Minimum Brinell Hardness	Minimum Elongation After Fracture, A %	Condition
(1)	(2)	(3)	(4)	(5)	(6)	(7)
i)	Drill rods	690	550	200	15	Induction hardened
ii)	Core tubes	780	680	229	15	Tempered/stress relieved
iii)	Other items			Not specified		

To access Indian Standards click on the link below:

https://www.services.bis.gov.in/php/BIS_2.0/bisconnect/knowyourstandards/Indian_standards/isdetails/

6 DIMENSIONS AND TOLERANCES

6.1 General

All dimensions and tolerances are in millimetres unless otherwise stated and shall be in accordance with [Table 3](#) to [Table 4](#) inclusive.

6.2 Conformity

In those industries where drilling depths are measured in metres, the rod lengths shall be 3 m, 1.5 m, or 0.75 m.

6.3 Eccentricity

The eccentricity is defined as the distance between the centres of the outer and inner diameters and may not exceed 5 percent of nominal wall thickness Q . The eccentricity is calculated according to the formula:

$$\frac{Q_{Max} - Q_{Min}}{2Q_{nom}} \times 100$$

Where, Q_{Max} and Q_{Min} are measured values in the same section.

6.4 Straightness

When measured over the whole length of the tube by rolling against a straightedge, the maximum deviation shall not be greater than following:

- a) For drill rods 1 in 2 000; and
- b) For core tubes 1 in 2 000.

6.5 Technical conditions

Tubes should be made seamless. Tube rolling technique and machining operations are optional. Tube straightness is checked by rolling the tube on a horizontal or slightly inclined flat surface. When rolling, no clearances shall be seen between the rod ends and the surface, nor between the middle of the rod (tube) and the surface. Hole drilling by wireline system A equipment shall be cased by System A casing as specified in ISO 3551-1 and [Table 2](#).

Table 2 System of Dimensional Identification Letters

(Clause [6.5](#))

SI No.	Identification Letters	Meanings of Identification Letters
(1)	(2)	(3)
i)	$A, A_1, \text{ etc}$	Outside diameters; A being largest; $A_1, A_2, \text{ etc}$ progressively smaller
ii)	$B, B_1, \text{ etc}$	Inside diameters; B being smallest; $B_1, B_2, \text{ etc}$ progressively larger
iii)	$C, C_1, \text{ etc}$	External lengths; C being longest; $C_1, C_2, \text{ etc}$ progressively shorter
iv)	$D, D_1, \text{ etc}$	Internal lengths; D being longest; $D_1, D_2, \text{ etc}$ progressively shorter
v)	$E, E_1, \text{ etc}$	Major diameter of pin threads; E being largest; $E_1, E_2, \text{ etc}$ smaller
vi)	$F, F_1, \text{ etc}$	Minor diameter of pin threads; F being largest; $F_1, F_2, \text{ etc}$ smaller
vii)	Thread pitch (threads per inch)	Pin threads
viii)	$G, G_1, \text{ etc}$	Width at root of pin thread
ix)	$H, H_1, \text{ etc}$	Length of o.d. machined for external threading
x)	$J, J_1, \text{ etc}$	Minimum length for full depth of pin threads
xi)	$K, K_1, \text{ etc}$	Length of relief at the starting point of pin threads
xii)	$L, L_1, \text{ etc}$	Angle of bevel for pin thread shoulder
xiii)	$M, M_1, \text{ etc}$	Major diameter of box threads; M being largest; $M_1, M_2, \text{ etc}$ smaller
xiv)	$N, N_1, \text{ etc}$	Minor diameter of box; N being largest; $N_1, N_2, \text{ etc}$ smaller
xv)	Thread pitch (threads per inch)	Box threads
xvi)	$P, P_1, \text{ etc}$	Width at root of box threads
xvii)	$Q, Q_1, \text{ etc}$	Length of i.d. machined for internal threading
xviii)	$R, R_1, \text{ etc}$	Minimum length for full depth of box threads
xix)	$S, S_1, \text{ etc}$	Length of counter bore at the starting of box threads
xx)	$T, T_1, \text{ etc}$	Angle of bevel for thread shoulder
xxi)	$U, U_1, \text{ etc}$	Included angles, Internal and external

Table 2 (Concluded)

SI No.	Identification Letters	Meanings of Identification Letters
(1)	(2)	(3)
xxii)	V, V ₁ , etc	Internal angles, not pertaining to threaded connections
xxiii)	W, W ₁ , etc	External angles, not pertaining to threaded connections
xxiv)	X	Diamond set dimensions: External (o.d.)
xxv)	Y	Diamond set dimensions: Internal (i.d.)

NOTES

1 All decimal dimensions indicate allowable tolerances.

2 The following common abbreviations have sometimes been used in tables in the English version for the sake of simplicity:
o.d. = outside diameter; and
i.d. = inside diameter.

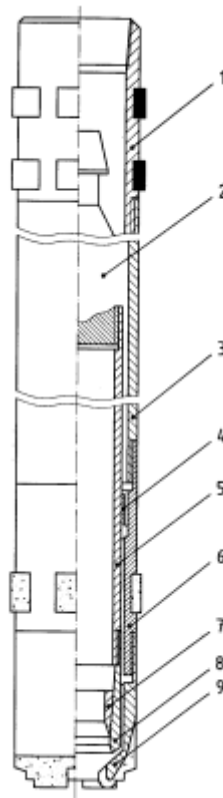

Key

1	Head (not standardized)	6	Reaming shell
2	Bearing unit (not standardized)	7	Core lifter
3	Outer core barrel	8	Core lifter case
4	Stabilizer (not standardized)	9	Bit
5	Retractable core barrel		

FIG. 1 WIRELINE CORE BARREL ASSEMBLY

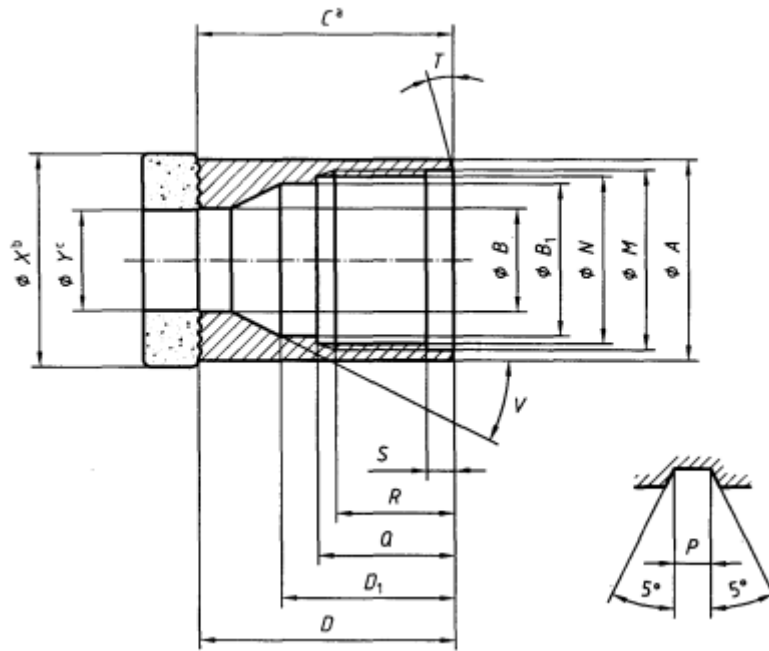

where

a = Clear of diamond

b = Set o.d.



c = Set i.d.

Table 3 Wireline Core Bit

(See [Fig. 2](#))

Sl No.	Dimension	WLA	WLB	WLN	WLH	
(1)	(2)	(3)	(4)	(5)	(6)	
i)	A	Max	46.66	57.96	73.91	94.31
		Min	46.56	57.86	73.81	94.21
ii)	B	Max	27.89	37.70	48.82	64.69
		Min	27.76	36.91	48.02	63.90
iii)	B ₁	Max	36.91	46.43	60.72	78.18
		Min	36.12	45.64	59.93	77.39
iv)	C	Min	57.91	66.04	65.41	96.22
		Max	58.71	66.83	66.20	97.01
v)	D	Max	58.71	66.83	66.20	97.01
		Min	57.91	66.04	65.41	96.22
vi)	D ₁	Max	49.61	57.55	54.37	83.74
		Min	48.82	56.75	53.58	82.95
vii)	M	Max	42.09	52.43	67.51	85.78
		Min	42.04	52.37	67.46	85.70
viii)	N	Max	40.59	50.85	65.99	84.20
		Min	40.51	50.80	65.94	84.12
ix)	Thread pitch	6.35	6.35	6.35	6.35	
x)	P	Max	3.20	3.20	3.20	3.20
		Min	3.12	3.12	3.12	3.12
xi)	Q	Max	42.29	42.52	42.55	42.75
		Min	42.16	42.39	42.42	42.62
xii)	R	Min	38.89	38.89	38.89	38.89
xiii)	S	Max	7.4	7.4	7.4	7.14
		Min	6.35	6.35	6.35	6.35
xiv)	T	15°	15°	15°	15°	

Table 3 (Concluded)

Sl No.	Dimension		WLA	WLB	WLN	WLH
(1)	(2)		(3)	(4)	(5)	(6)
xv)	V		30°	30°	30°	30°
xvi)	X	Max	47.75	59.69	75.44	95.76
		Min	47.50	59.44	75.18	95.38
xvii)	Y	Max	27.10	36.53	47.75	63.63
		Min	26.85	36.27	47.50	63.37

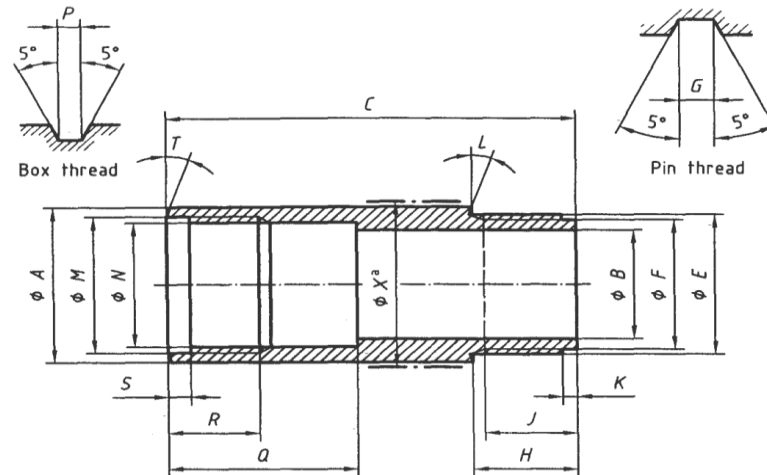

where

a = Set o.d.

Sl No.	Dimension		WLA	WLB	WLN	WLH
(1)	(2)		(3)	(4)	(5)	(6)
i)	A	Max	46.66	57.96	73.91	94.31
		Min	46.56	57.86	73.81	94.21
ii)	B	Max	36.51	46.04	60.33	77.79
		Min	36.36	45.86	60.12	77.53
iii)	C	Max	162.32	159.15	171.85	182.96
		Min	161.53	158.35	171.05	182.17
iv)	E	Max	41.96	52.30	67.39	85.62
		Min	41.91	52.25	67.34	85.55
v)	F	Max	40.44	50.72	65.86	84.05
		Min	40.39	50.67	65.81	83.97
vi)	Thread pitch		6.35	6.35	6.35	6.35
vii)	G	Max	3.20	3.20	3.20	3.20
		Min	3.12	3.12	3.12	3.12
viii)	H	Max	41.28	41.38	41.28	41.20
		Min	41.15	41.25	41.15	41.07
ix)	J	Min	38.89	38.89	38.89	38.89
x)	K	Max	7.14	7.14	7.14	7.14
		Min	6.35	6.35	6.35	6.35
xi)	L		15°	15°	15°	15°
xii)	M	Max	42.09	52.43	67.51	85.78
		Min	42.04	52.37	67.46	85.70
xiii)	N	Max	40.59	50.85	65.99	84.20
		Min	40.51	50.80	65.94	84.12
xiv)	Thread pitch		6.35	6.35	6.35	6.35
xv)	P	Max	3.20	3.20	3.20	3.20
		Min	3.12	3.12	3.12	3.12
xvi)	Q	Max	61.01	61.32	67.69	74.04
		Min	60.88	61.19	67.56	73.91
xvii)	R	Min	38.89	38.89	38.89	38.89

Sl No.	Dimension	WLA	WLB	WLN	WLH	
(1)	(2)	(3)	(4)	(5)	(6)	
xviii)	S	Max	7.14	7.14	7.14	7.14
		Min	6.35	6.35	6.35	6.35
xix)	T	15°	15°	15°	15°	
xx)	X	Max	48.13	60.07	75.82	96.27
		Min	47.88	59.82	75.57	95.89

FIG. 3 WIRELINE REAMING SHELL

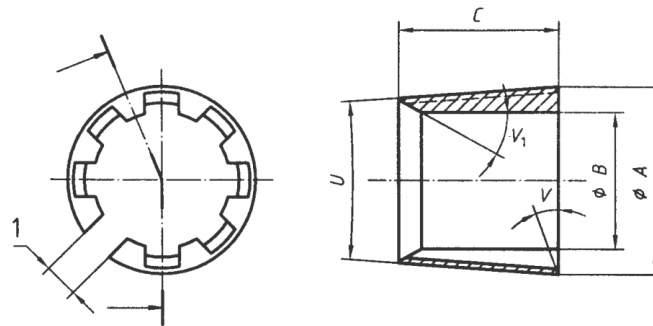

Key
1 Gap

Sl No.	Dimension	WLA	WLB	WLN	WLH	
(1)	(2)	(3)	(4)	(5)	(6)	
i)	A	Max	30.23	40.23	52.04	68.94
		Min	30.18	40.18	51.99	68.88
ii)	B	Max	26.59	36.02	47.12	62.87
		Min	26.54	35.97	47.07	62.81
iii)	C	Max	22.62	25.80	28.97	38.50
		Min	21.83	25.00	28.18	37.70
iv)	U	Max	5° to 15'	5° to 15'	5° to 15'	5° to 15'
		Min	4° to 45'	4° to 45'	4° to 45'	4° to 45'
v)	V	0°	0°	0°	0°	
vi)	V ₁	30°	30°	30°	30°	

FIG. 4 WIRELINE CORE LIFTER

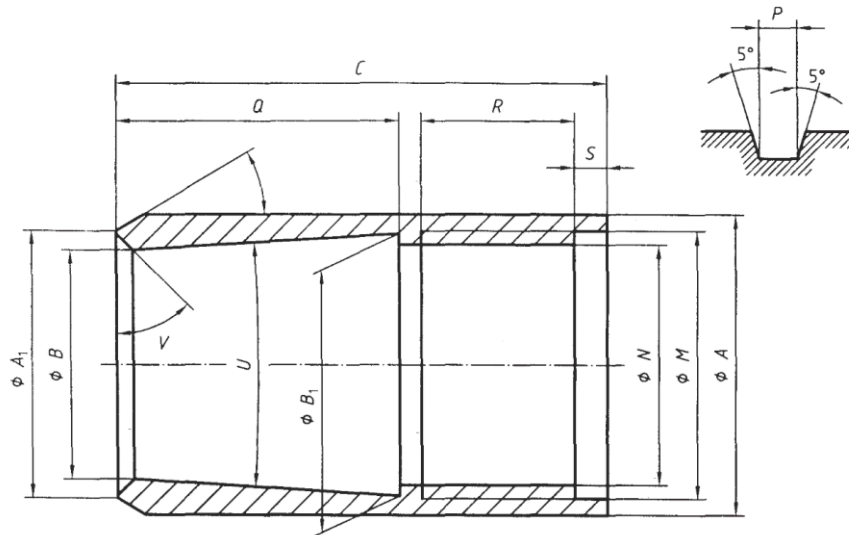

Sl No.	Dimension		WLA	WLB	WLN	WLH
(1)	(2)		(3)	(4)	(5)	(6)
i)	A	Max	32.94	43.00	55.93	73.23
		Min	32.89	42.95	55.88	73.18
ii)	A ₁	Max	30.68	40.41	52.73	67.99
		Min	30.63	40.35	52.68	67.94
iii)	B	Max	28.30	38.02	49.56	65.61
		Min	28.24	37.97	49.50	65.56
iv)	B ₁	Max	31.09	41.43	53.21	70.38
		Min	31.01	41.33	53.14	70.31
v)	C	Max	63.90	70.25	75.01	89.30
		Min	63.10	69.45	74.22	88.50
vi)	M	Max	31.32	41.10	53.47	70.69
		Min	31.27	41.05	53.42	70.64
vii)	N	Max	30.18	39.93	52.20	69.29
		Min	30.12	39.88	52.15	69.24
viii)	Thread pitch		3.175	3.175	3.175	3.175
ix)	P	Max	1.63	1.63	1.63	1.63
		Min	1.55	1.55	1.55	1.55
x)	Q	Max	40.08	44.85	51.59	67.07
		Min	39.29	44.05	50.80	66.28
xi)	R	Min	20.64	20.64	20.64	20.64
xii)	S	Max	3.97	3.97	3.97	3.97
		Min	3.18	3.18	3.18	3.18
xiii)	T		30°	30°	30°	30°
xiv)	U	Max	5° to 15°	5° to 15°	5° to 15°	5° to 15°
		Min	4° to 45°	4° to 45°	4° to 45°	4° to 45°
xv)	V		45°	45°	45°	45°

FIG. 5 WIRELINE CORE LIFTER CASE

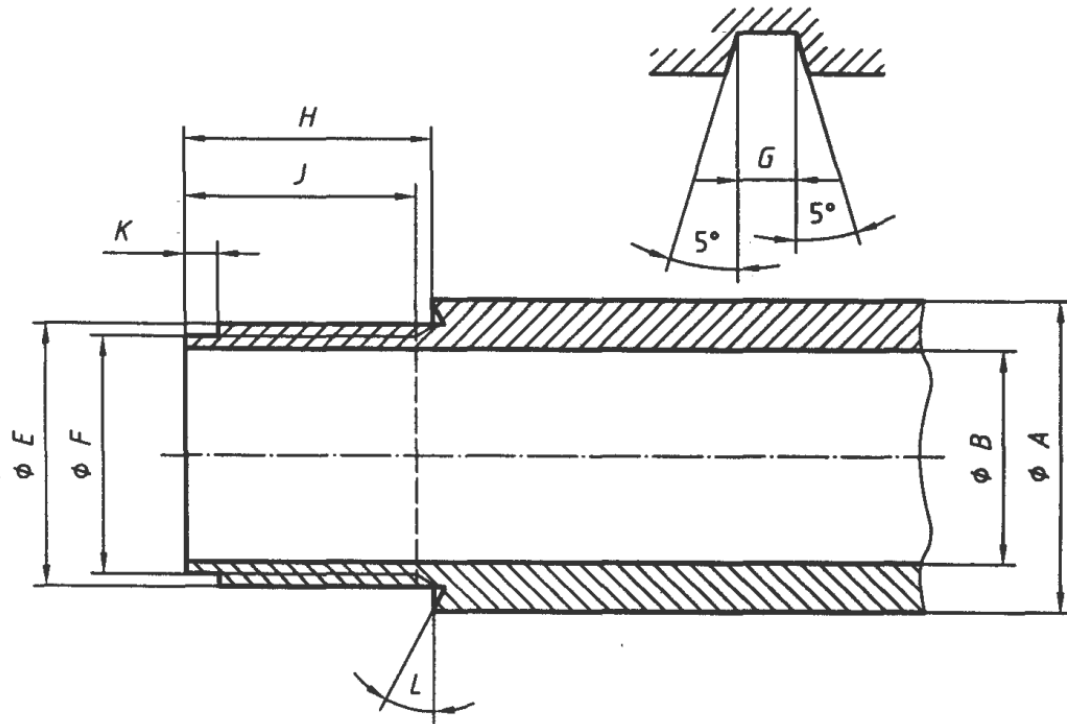

Sl No.	Dimension		WLA	WLB	WLN	WLH
(1)	(2)		(3)	(4)	(5)	(6)
i)	A	Max	46.19	57.33	73.23	92.33
		Min	46.04	57.15	73.03	92.08
ii)	B	Max	36.51	46.04	60.53	77.79
		Min	36.36	45.86	60.33	77.53
iii)	E	Max	41.96	52.30	67.39	05.62
		Min	41.91	52.25	67.34	85.55
iv)	F	Max	40.44	50.72	65.86	84.05
		Min	40.39	50.67	65.81	83.97
v)	Thread pitch		6.35	6.35	6.35	6.35
vi)	G	Max	3.20	3.20	3.20	3.20
		Min	3.12	3.12	3.12	3.12
vii)	H	Max	41.28	41.48	41.38	41.28
		Min	41.15	41.35	41.25	41.15
viii)	J	Min	38.89	38.89	38.89	38.89
ix)	K	Max	7.14	7.14	7.14	7.14
		Min	6.35	6.35	6.35	6.35
x)	L	Min	15°	15°	15°	15°

FIG. 6 WIRELINE CORE BARREL OUTER TUBE (LOWER END)

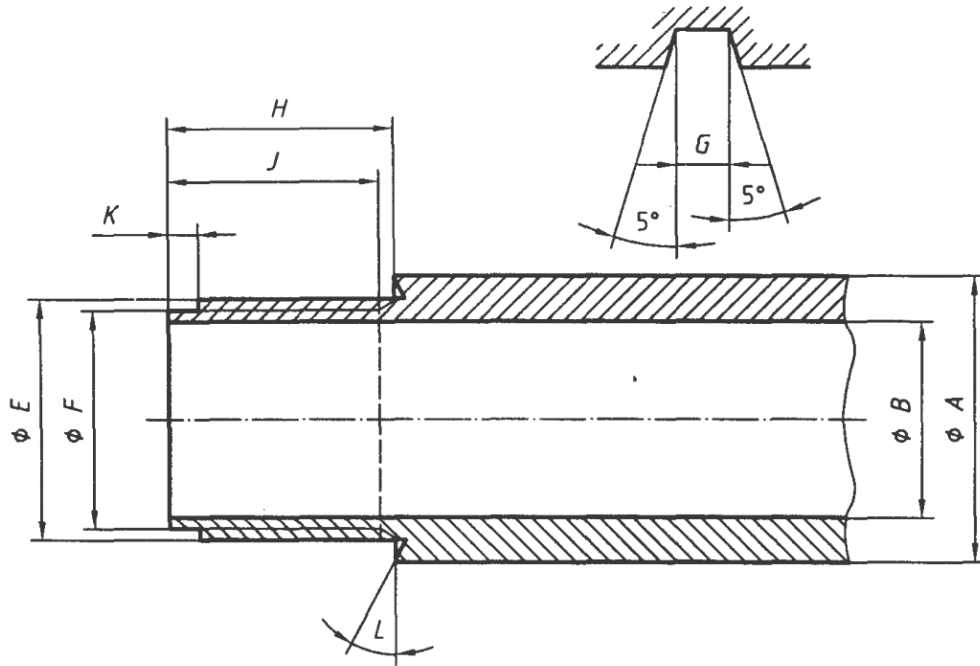

Sl No.	Dimension	WLA	WLB	WLN	WLH	
(1)	(2)	(3)	(4)	(5)	(6)	
i)	A	Max	32.67	42.99	55.74	73.23
		Min	32.54	42.86	55.56	73.03
ii)	B	Max	28.58	38.10	50.01	66.93
		Min	28.45	37.97	49.83	66.73
iii)	E	Max	31.24	40.97	53.34	70.56
		Min	31.19	40.92	53.29	70.51
iv)	F	Max	30.07	39.80	52.07	69.16
		Min	30.02	39.75	52.02	69.11
v)	Thread pitch	3.175	3.175	3.175	3.175	
vi)	G	Max	1.63	1.63	1.63	1.63
		Min	1.55	1.55	1.55	1.55
vii)	H	Max	22.10	22.10	22.10	22.10
		Min	21.97	21.97	21.97	21.97
viii)	J	Min	20.64	20.64	20.64	20.64
ix)	K	Max	3.97	3.97	3.97	3.97
		Min	3.18	3.18	3.18	3.18
x)	L	Min	0°	0°	0°	0°

FIG. 7 WIRELINE CORE BARREL INNER TUBE (LOWER END)



NOTE — For dimensions see [Table 9](#)

<i>Sl No.</i>	<i>Dimension</i>		<i>WLA</i>	<i>WLB</i>	<i>WLN</i>	<i>WLH</i>
(1)	(2)		(3)	(4)	(5)	(6)
i)	A	<i>Max</i>	44.60	55.75	70.05	89.15
		<i>Min</i>	44.45	55.58	69.85	88.90
ii)	B	<i>Max</i>	35.08	46.20	60.33	78.00
		<i>Min</i>	34.93	46.02	60.12	77.77

NOTE — Further details are given in [Annex A](#).

FIG. 8 DRILL ROD (SMOOTH PIPE)

ANNEX A

(Informative)

PRINCIPAL DIMENSIONS OF DRILL ROD THREADS

SI No.	Dimensions	WLA	WLB	WLN	WLH
(1)	(2)	(3)	(4)	(5)	(6)
i)	Thread tapering	1 : 28.64	1 : 28.64	1 : 28.64	2 : 28.64
ii)	Angle of thread arrival	1°	1°	1°	1°
iii)	Angle of thread profile	29°	29°	29°	29°
iv)	Thread pitch	6.350	8.466	8.466	8.466
v)	Maximum outside diameter of box thread in stop batt axis	41.325	52.125	66.425	84.655
vi)	Maximum outside diameter of box thread in stop shoulder axis	39.805	50.595	64.895	83.135
vii)	Mean spire depth of box thread	0.752	0.785	0.785	0.785
viii)	Width at root of box thread	3.00	4.06	4.06	4.06
ix)	Mean length of box thread from stop batt to internal angle of stop shoulder	41.8	44.9	44.9	45.0
x)	Minimum length for full depth of box thread	39.7	43.3	43.3	43.3
xi)	Minimum inside diameter of pin thread in stop batt axis	38.18	48.84	63.12	81.38
xii)	Minimum inside diameter of pin thread in shoulder axis	39.80	50.47	64.74	83.01
xiii)	Mean spire depth of pin thread	0.740	0.800	0.800	0.800
xiv)	Width at root of pin thread	3.00	4.06	4.06	4.06
xv)	Mean length of pin thread from stop batt to external angle of stop shoulder	41.3	44.4	44.4	44.4
xvi)	Minimum length for full depth of pin thread	39.7	43.7	43.7	43.7
xvii)	Angles of bevel for thread stop battes and stop shoulders	15°	15°	15°	15°

NOTE — Many dimensions are approximate.

ANNEX B

(Foreword)

COMMITTEE COMPOSITION

Diamond Core and Waterwell Drilling Sectional Committee, MED 21

<i>Organization</i>	<i>Representative(s)</i>
Geological Survey of India, New Delhi	SHRI AJAY AGARWAL (<i>Chairperson</i>)
Aqseptence Group (India) Pvt Ltd (Formaly Known as Johanson Screens India Pvt Ltd), Sanand	SHRI SHIV NARAYAN SINGH SHRI SHIVEN AMIN (<i>Alternate</i>)
Atlas Copco (I) Ltd, Pune	SHRI SHUDHANSHU NIGAM SHRI S. DATTA MAJUMDAR (<i>Alternate</i>)
Central Ground Water Board, Faridabad	SHRI G. L. MEENA SHRI NIDHISH VERMA (<i>Alternate</i>)
Central Mine Planning and Design Institute, Ranchi	SHRI ANIL SAVANUR SHRI A. V. RAMAKRISHNA (<i>Alternate</i>)
Epiroc Mining India Limited, Nashik	SHRI SUJEET KUMAR SHRI CHANDAN GHOSH (<i>Alternate</i>)
Geological Survey of India, Kolkata	SHRI ANUP KUMAR JOHRI SHRI C. B. TIWARI (<i>Alternate I</i>) SHRI S. SHANKAR (<i>Alternate II</i>)
Indian Institute of Technology (ISM), Dhanbad	MOHAMMED HAMID SIDDIQUE SHRI PAWAN GUPTA (<i>Alternate I</i>) SHRI VINAY KUMAR RAJAK (<i>Alternate II</i>)
Indian Institute of Technology Kharagpur, Kharagpur	PROF KHANINDRA PATHAK SHRIMATI SUNITA MISHRA (<i>Alternate</i>)
Indian Institute of Technology, Kanpur	PROF J. RAMKUMAR PROF SUDHANSHU SHEKHAR SINGH (<i>Alternate</i>)
Indian Institute of Technology, Roorkee	PROF B. K. GANDHI SHRI VARUN KUMAR SHARMA (<i>Alternate</i>)
Indian Pump Manufacturers Association, Mumbai	SHRI YOGESH MISTRY SHRI UTKARSH A. CHHAYA (<i>Alternate</i>)
Kores (India) Ltd, Mumbai	SHRI SANDEEP DHOLI
Mining Associates Pvt Ltd, Asansol	SHRI RAM BABU BANSAL
Rites Ltd, Gurugram	SHRI S. KUNAL
Rockdrill (India), Jodhpur	SHRI KAMAL KISHOR GUPTA SHRI RAVINDRA KUMAR GUPTA (<i>Alternate</i>)
Sandvik Smith Asia Limited, Medak	SHRI RANGAYYA NAIDU SHRI N. BHASKARA REDDY (<i>Alternate</i>)
In Personal Capacity (<i>F-401, Maruti Sadan, Begumpet, Hyderabad</i>)	SHRI A. B. ANAND

<i>Organization</i>	<i>Representative(s)</i>
In Personal Capacity (<i>D-5/10, Rail Vihar, Indirapuram, Ghaziabad</i>)	SHRI P. C. DEWLI
In Personal Capacity (<i>90 Mayur Vihar, Sec 48, Chandigarh</i>)	SHRI MAHESH CHANDRA JINDAL
BIS Directorate General	SHRI K. V. RAO, SCIENTIST 'F'/SENIOR DIRECTOR AND HEAD (MECHANICAL ENGINEERING) [REPRESENTING GENERAL (<i>Ex-officio</i>)]

Member Secretary
SHRI SHUBHAM YADAV
SCIENTIST 'C'/DEPUTY DIRECTOR
(MECHANICAL ENGINEERING), BIS

Bureau of Indian Standards

BIS is a statutory institution established under the *Bureau of Indian Standards Act, 2016* to promote harmonious development of the activities of standardization, marking and quality certification of goods and attending to connected matters in the country.

Copyright

BIS has the copyright of all its publications. No part of these publications may be reproduced in any form without the prior permission in writing of BIS. This does not preclude the free use, in the course of implementing the standard, of necessary details, such as symbols and sizes, type or grade designations. Enquiries relating to copyright be addressed to the Head (Publication & Sales), BIS.

Review of Indian Standards

Amendments are issued to standards as the need arises on the basis of comments. Standards are also reviewed periodically; a standard along with amendments is reaffirmed when such review indicates that no changes are needed; if the review indicates that changes are needed, it is taken up for revision. Users of Indian Standards should ascertain that they are in possession of the latest amendments or edition by referring to the website-www.bis.gov.in or www.standardsbis.in.

This Indian Standard has been developed from Doc No.: MED 21 (19184).

Amendments Issued Since Publication

Amend No.	Date of Issue	Text Affected

BUREAU OF INDIAN STANDARDS

Headquarters:

Manak Bhavan, 9 Bahadur Shah Zafar Marg, New Delhi 110002

Telephones: 2323 0131, 2323 3375, 2323 9402

Website: www.bis.gov.in

Regional Offices:

	Telephones
Central : 601/A, Konnectus Tower -1, 6 th Floor, DMRC Building, Bhavbhuti Marg, New Delhi 110002	{ 2323 7617
Eastern : 8 th Floor, Plot No 7/7 & 7/8, CP Block, Sector V, Salt Lake, Kolkata, West Bengal 700091	{ 2367 0012 2320 9474
Northern : Plot No. 4-A, Sector 27-B, Madhya Marg, Chandigarh 160019	{ 265 9930
Southern : C.I.T. Campus, IV Cross Road, Taramani, Chennai 600113	{ 2254 1442 2254 1216
Western : Manakalya, 4 th Floor, NTH Complex (W Sector), F-10, MIDC, Andheri (East), Mumbai 400093	{ 283 25838

Branches : AHMEDABAD, BENGALURU, BHOPAL, BHUBANESHWAR, CHANDIGARH, CHENNAI, COIMBATORE, DEHRADUN, DELHI, FARIDABAD, GHAZIABAD, GUWAHATI, HARYNA, HUBLI, HYDERABAD, JAIPUR, JAMMU & KASHMIR, JAMSHEDPUR, KOCHI, KOLKATA, LUCKNOW, MADURAI, MUMBAI, NAGPUR, NOIDA, PARWANOO, PATNA, PUNE, RAIPUR, RAJKOT, SURAT, VIJAYAWADA.