

---

---

# ऐजिटेटर उपकरण — रीति संहिता

( पहला पुनरीक्षण )

## Agitator Equipment — Code of Practice

( First Revision )

ICS 71.120

© BIS 2024



भारतीय मानक ब्यूरो  
BUREAU OF INDIAN STANDARDS  
मानक भवन, 9 बहादुर शाह ज़फर मार्ग, नई दिल्ली - 110002  
MANAK BHAVAN, 9 BAHADUR SHAH ZAFAR MARG  
NEW DELHI - 110002

[www.bis.gov.in](http://www.bis.gov.in) [www.standardsbis.in](http://www.standardsbis.in)

## FOREWORD

This Indian Standard (First Revision) was adopted by the Bureau of Indian Standards, after the draft finalized by the Chemical Engineering Plants and Related Equipment Sectional Committee had been approved by the Mechanical Engineering Divisional Council.

This standard was first published in 1980. The present revision has been taken up with a view of incorporating the modification found necessary as a result of experience gained in the use of this standard. Also, in this revision, the standard has been brought into the latest style and format of Indian Standards, and references to Indian Standard, wherever applicable have been updated.

The composition of the Committee responsible for the formulation of this standard is given in [Annex B](#).

For the purpose of deciding whether a particular requirement of this standard is complied with, the final value, observed or calculated, expressing the result of a test or analysis, shall be rounded off in accordance with IS 2 : 2022 'Rules for rounding off numerical values (*second revision*)'. The number of significant places retained in the rounded off value should be the same as that of the specified value in this standard.

*Indian Standard*

## AGITATOR EQUIPMENT — CODE OF PRACTICE

( *First Revision* )

### 1 SCOPE

This Indian Standard lays down the standard recommended capacities of agitator equipment and general requirements of agitator equipment. It also provides guidelines on the selection of impeller, power assessment drive, bearing arrangements and shaft design.

### 2 REFERENCES

The standard given below contains provisions which, through reference in this text, constitute provisions of this standard. At the time of publication, the edition indicated was valid. All standards are subject to revision, and parties to agreements based on this standard are encouraged to investigate the possibility of applying the most recent edition of this standard.

<i>IS No.</i>	<i>Title</i>
IS 2825 : 1969	Code for unfired pressure vessels

### 3 NOMENCLATURE

For the purpose of this standard, the different parts of agitator equipment are numbered as given below. (see [Fig. 1](#))

1. Shell	15. Gear box
2. Shell cover	16. Motor
3. Vessel flange	17. Draft tube
4. Agitator shaft	18. Baffles
5. Impeller	19. Mechanical seal
6. Impeller hub	20. Lantern ring
7. Rigid coupling	21. Bearing housing
8. In-tank coupling	22. Sparger pipe
9. Stuffing box	23. Headers
10. Stuffing gland	24. Jacket
11. Packing	25. Heating coil
12. Thrust bearing	26. Half tubes (limpet coils)
13. Roller bearing	27. Manhole
14. Drive mounting	28. Vessel support

### 4 TERMINOLOGY

For the purpose of this standard the following definitions shall apply:

**4.1 Agitator** — The assembly consisting of impeller, impeller shaft and drive including other

parts such as gland and bearing used in conjunction with the above.

**4.2 Anchor** — Basically a paddle type impeller which is profiled to sweep the wall of the containing vessel with a small clearance.

**4.3 Baffle** — An element fixed inside the vessel to impede swirl.

**4.4 Draught Tube** — A tubular fitting which is arranged to direct the liquid flow produced by the impeller.

**4.5 Filling Ratio** — The ratio of liquid depth in the vessel to vessel diameter.

**4.6 11 Fully Baffled Condition** — A condition when any further increase in baffling causes no significant increase in power consumption, this may be considered as a state where the liquid swirl in the vessel has become negligibly small and when all the power input to the impeller expended to create turbulence.

**4.7 Impeller** — The actual element which imparts movement to the charge (fluid).

**4.8 Paddle** — An impeller with four or fewer blades, horizontal or vertical, and essentially having a high impeller to vessel diameter ratio.

**4.9 Propeller** — A high speed impeller which essentially imparts axial thrust to the fluid.

**4.10 Swirling** — The continuous rotation of liquid about a fixed axis.

**4.11 Turbine** — An impeller with essentially constant blade angle with respect to a vertical plane, over its entire length or over finite sections, having blades either vertical or set at an angle less than 90° with the vertical.

**4.12 Vortex** — A depression in the surface of a liquid produced by swirling.

### 5 RECOMMENDED CAPACITIES AND VESSEL SIZES

The capacities and the corresponding vessel diameters are shown in [Table 1](#). The vessel diameter shown against each capacity are selected so as to obtain an approximate filling ratio of 1.0 for vessels with torispherical bottom ends. However, depending on the filling ratio requirement for a specific application and other process considerations, the vessel diameters may be suitably selected.

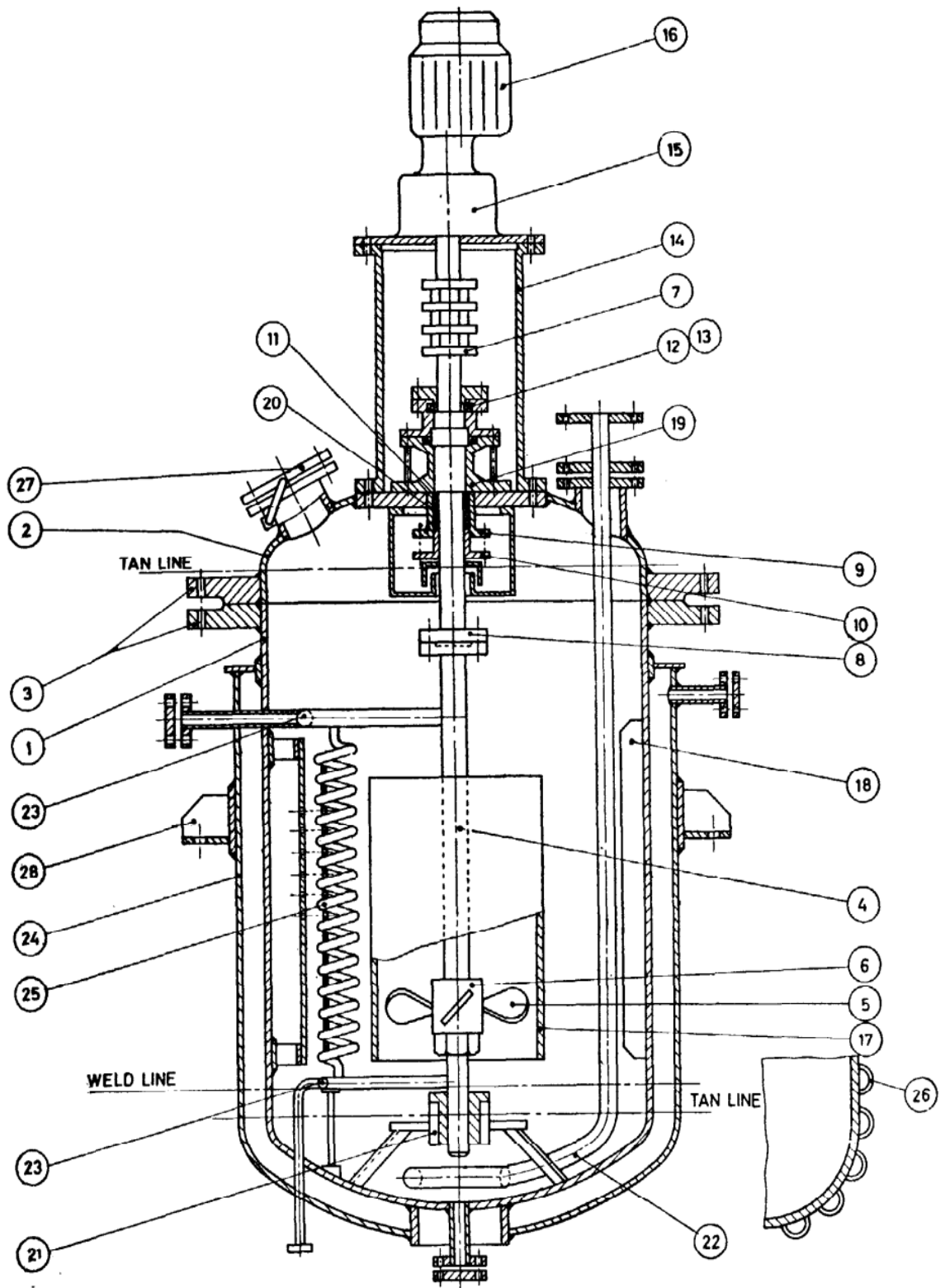

FIG. 1 AGITATOR ASSEMBLY

## 6 GENERAL REQUIREMENTS OF MIXING EQUIPMENT

The general requirements of the mixing equipment given below mainly relate to vertical vessels only.

### 6.1 Filling Ratio

Filling ratio normally varies between 0.5 and 1.5 and a value approximately equal to 1.0 is suitable for most of the applications. However, in some applications like dispersing gas in a liquid, a filling ratio of about 2.0 may be sometimes necessary in order to maintain a sufficiently long period of contact between gas and liquid. Normally for the same agitating effect, the power consumption per unit volume increases as the filling ratio departs from unity.

### 6.2 Shape of the Vessel

Vertical cylindrical vessels with dished bottoms are usually chosen for the mixing operation but use of cylindrical vessels with flat or shallow coned-bottoms is not uncommon. The significance of the bottom shape of the vessel increases as the filling ratio reduces, and other things being equal vessels with dished bottoms tend to be economical in power consumption. The flat bottomed and cone-bottomed vessels have the disadvantage of low agitation efficiency in the corner formed between the wall and flat bottom in the former case and in the apex of the cone bottom in the latter case. In mixing applications like suspension of heavy solids in a liquid, the presence of the low agitation efficiency areas allows the settlement of the solids which is detrimental to the process requirements. In such cases, fillets should be inserted in the corners and in the apex to avoid the low agitation areas.

### 6.3 Roughness of Vessel Walls

Power consumption will be more in a rough walled vessel than a smooth walled vessel due to the increase in local turbulence at the walls. Even if the turbulence is the primary objective of the agitator, the local increase in turbulence at the walls is of little value and an increase in turbulence when definitely required is best achieved by baffles. Hence vessel walls should be as smooth as possible.

### 6.4 Baffles

In applications where turbulence is primary requisite, the baffles are used to promote turbulence. Baffles also allow the system to absorb relatively large amount of power where it is needed for effective mixing, avoiding vortex and swirling action. Four numbers of baffles are sufficient to achieve a fully baffled condition for vessels of diameter up to 2 500 mm and above which six number may be necessary. Baffles are straight flats and normally of width one-tenth of the vessel

diameter. However, when the baffles are used in conjunction with a heating coil inside the vessel, the baffle width may be reduced to one-twelfth of the vessel diameter. The baffles should be mounted vertically and radially in a vessel at equal spacings leaving a clearance of one-third to one-fourth of the baffle width between the vessel walls and baffles to reduce and tendency for solid deposits to form in the corners between vessel wall and baffles and to facilitate cleaning of the vessel. Baffles should normally extend up to liquid surface with a small clearance at the bottom end between baffles and flat bottomed ends.

### 6.5 Draft Tube

The draft tube is a tubular fitting surrounding the impeller and part of the impeller shaft. Draft tube is used to ensure a specific flow pattern to be set up in the fluid system for effective mixing. The size and location of the draft tube shall be determined based on the mechanical and mixing performance characteristics of the particular mixing application. Draft tubes are normally used in conjunction with axial flow impellers.

### 6.6 Impellers

**6.6.1** Essentially most agitating operations may be effected with any type of impellers. Use of an impeller which is not best for a particular duty may result in high power consumption or be slow to achieve the required results. For equipment of low cost, power consumption and efficiency are often of secondary importance provided the required effect is produced, and in such cases choice of best impeller is not critical. Problems which are likely to require much power or equipment, or to be specially difficult or critical for any reason should be investigated on an appropriate experimental scale and are to be scaled up (*see* [8](#)).

#### 6.6.2 Type of Impellers

The impellers are classified into the following types:

- a) Propellers — Propellers are high speed impellers of the axial flow type. Marine type of impellers are most common in use and their shapes and contours vary widely.
- b) Turbines — This type of impellers cover a wide variety of impellers which have nothing in common in regard to design, direction of discharge or character of flow. Impellers of this type which are in common use are flat blade, disc and blade, pitched blade, curved blade, tilted blade and shrouded types.

- c) Paddles — The common types of impellers in this category are flat, paddle, anchor, plate, gate, and helix.
- d) High Shear Impellers — High shear impellers may be briefly characterized as low flow high velocity impellers suitable

for application like emulsification and homogenization.

**6.6.3** Some of the impellers in common use are shown in [Fig. 2](#). The general description of these impellers and their applications are given in [Table 2](#).

**Table 1 Capacities and Vessel Diameters**

(Clause 5)

SI No.	Nominal Capacity	Vessel Outside Diameter
	l	mm
(1)	(2)	(3)
i)	250	700
ii)	400	800
iii)	630	1 000
iv)	750 <sup>1)</sup>	1 000 <sup>1)</sup>
v)	1 000	1 200
vi)	1 250 <sup>1)</sup>	1 300 <sup>1)</sup>
vii)	1 600	1 400
viii)	2 000 <sup>1)</sup>	1 500 <sup>1)</sup>
ix)	2 500	1 600
x)	3 200 <sup>1)</sup>	1 700 <sup>1)</sup>
xi)	4 000	1 800
xii)	5 000 <sup>1)</sup>	2 000 <sup>1)</sup>
xiii)	6 300	2 100
xiv)	8 000 <sup>1)</sup>	2 300 <sup>1)</sup>
xv)	10 000	2 400

<sup>1)</sup> These values are second preference values.

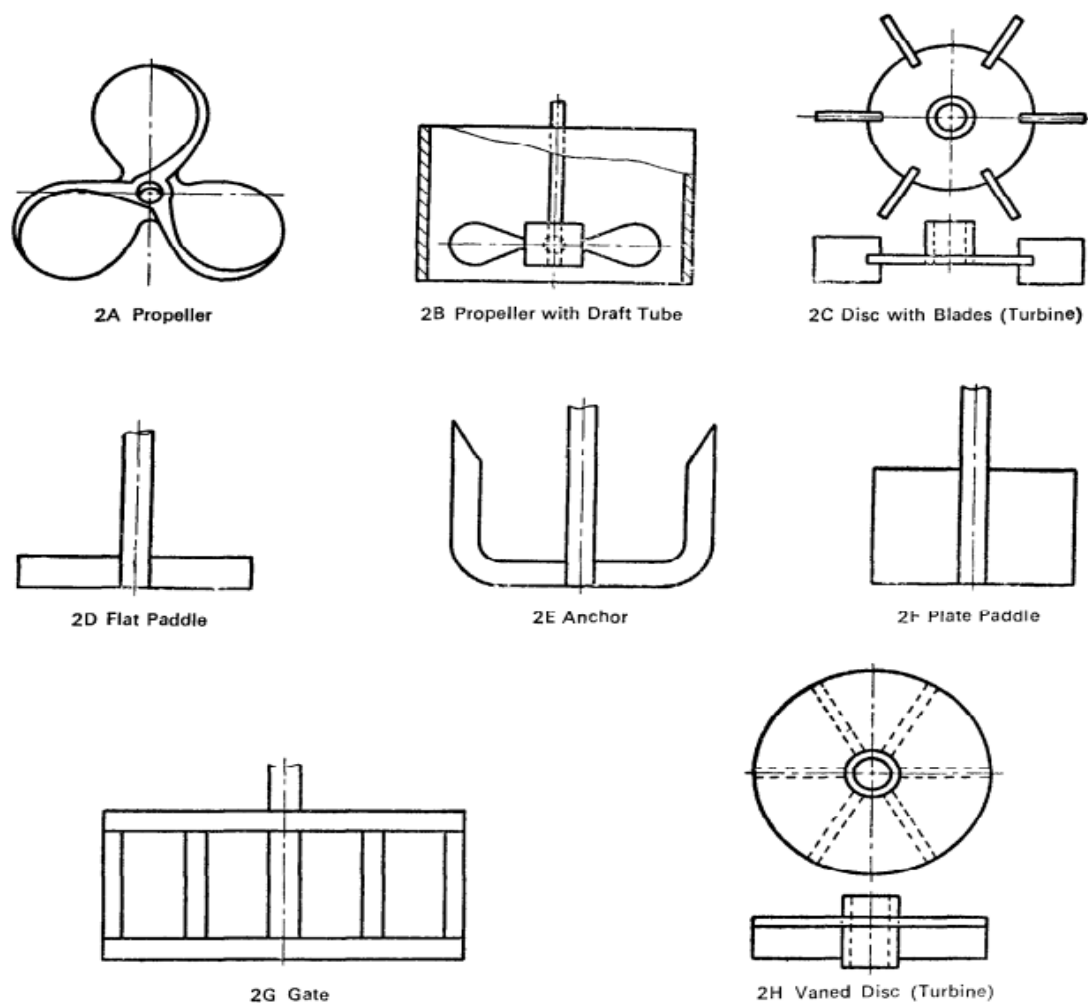

FIG. 2 TYPES OF IMPELLERS

Table 2 Impellers in Common Use

(Clause 6.6.3)

SI No.	Type of Impeller	Description	Application
(1)	(2)	(3)	(4)
i)	Propeller	It has wide variety of forms like possible form simple twisted arms to properly formed marine propellers. There is no standardization of pitch or number of blades among manufacturers. Marine type propellers are usually less than $1/4^{\text{th}}$ of the vessel diameter.	It is generally used for high speed agitator operating over wide speed range. The mass flow is vertical and a little circumferential. It is economical on power. It is suitable for duties where agitation is not very intense and unsuitable for high viscosities. It is also used for relatively small scale blending operations.
ii)	Propeller with draft tube	It is a propeller fitted below or just inside the lower end of draft tube. Baffles may be fitted in the draft tube. Top of draft tube may be just above or below the standing liquid level.	Its application is similar to those of simple propeller, but more positive turnover of liquid and its flow through the impeller is ensured which is advantageous in wetting out some solids and mixing some immiscible liquids. By suitable location of the top level of the draft tube, a pouring action which will drown floating solids, is achieved.

Table 2 (Concluded)

SI No.	Type of Impeller	Description	Application
(1)	(2)	(3)	(4)
iii)	Turbine	Flat discs with blades are attached to periphery. Similar effects are produced with the same number of blades directly attached to a boss. Overall diameter of the impeller is usually 1/3 <sup>rd</sup> of the vessel diameter.	It is generally used for moderately fast running agitator. It is particularly suitable for high intensities of agitation and high power inputs are recommended for applications where gas dispersion combined with intense agitation is required.
iv)	Flat paddle	Single flat blade (two arms) are usually about 2/3 <sup>rd</sup> of the vessel diameter.	It is generally used for speed agitator capable of producing high intensities of agitation, especially when baffled.
v)	Anchor	The agitator follows closely the contour of the vessel normally with a clearance of 25 mm to 40 mm between impeller and vessel wall.	It is for a large, low speed agitator and useful where the wall film must be disturbed like in heat transfer to viscous liquids from jacket, or where build-up of solids on the wall is likely, as in crystallisation. At low speeds, it has a very gentle action and will prevent caking in the bottom of vessel without vigorous agitation elsewhere. It is widely used in enamelled equipment.
vi)	Plate	A square or rectangular plate is bisected by the shaft on which it is mounted. It has a length usually 1/3 to 1/2 of that of vessel diameter.	It has similar applications to those of flat paddle, but allows more clearance for heating coils fittings, etc., in the vessel. When the depth of the plate is large relative to liquid depth, vertical movement of the liquid is less than that of a paddle of equivalent power.
vii)	Gate	It is an assembly of horizontal and vertical strips, sometimes with diagonal bracing. It is normally of length approaching vessel diameter and of depth about 1/2 to 3/4 <sup>th</sup> of overall length.	It is for a large low speed agitator of similar applications to those of anchor, but normally allows more clearance for coils and internal fittings in the vessel. It does not have the close sweeping effect of an anchor on the vessel walls and boss.
viii)	Vaned disc	It is a circular disc, usually 1/6 to 1/2 of vessel diameter with radial vanes 1/6 to 1/24 of disc diameter deep on its underside	It is for a small or moderately sized high speed agitator, limited usually to gas dispersion. The gas is fed under the centre of the disc. The power consumption without gas flow will be much higher than when gas is on, and drive should be adequate to cover the gasless condition.

## 7 GUIDELINES FOR THE SELECTION OF IMPELLER AND SCALING UP

### 7.1 Agitation

**7.1.1** In all applications of agitation, the primary effects are concerned with one or more of the following three physical processes:

- Mass transfer;
- Heat transfer; and
- Dispersion of solids, liquids or gases.

**7.1.2** Agitation does not directly affect the chemical reaction, if involved, but the rate of chemical reaction taking place may be influenced by one or more of the above primary effects. The factors

which influence the rate and degree of mixing as well as the efficiency are as follows:

- Characteristics of impeller — Its shape, speed, dimensions, and position in the vessel;
- Physical properties of the fluids — Densities, viscosities and physical states; and
- Vessel configuration — Shape and dimensions of the containing vessel and of any fittings which may be immersed in the fluid.

**7.2** Although agitation is concerned with obtaining the primary effects mentioned above, it is not easy to specify the exact circumstances needed to achieve



them efficiently. This is because of the fact that the physical properties of the materials being processed are themselves the main factors which determine the choice of impeller and because these physical properties of the fluids vary widely.

in the form of general mass flow and turbulence. Different mixing problems require different proportions of these two forms of kinetic energy at different levels of intensity. Characteristics required for various operations are given in [Table 3](#).

### 7.3 All agitators impart kinetic energy to the fluids

**Table 3 Characteristics Required for Specific Operations**

(Clause [7.3](#), [7.5](#) and [8.3](#))

Sl No.	Duty	Mass Flow		Turbulence	Recommended Basis for 'Scaling-Up'
		Direction	Quality		
(1)	(2)	(3)	(4)	(5)	(6)
i)	Heat transfer:				
	a) To jacket	Circumferential	Large	Low	Constant tip speed
	b) To coil	Circumferential and little vertical	Large	Low	
ii)	Suspending solids:				
	a) Light solids	Vertical	Small	Low	Constant tip speed
	b) Medium solids	Vertical	Moderate	Moderate	
	c) Heavy solids	Vertical	Large	Moderate or high	
iii)	Blending miscible liquids:				
	a) Thin liquids	Vertical and little circumferential	Small	Moderate	Constant tip speed
	b) Medium liquids	Vertical and little circumferential	Small	Moderate	
	c) Viscous liquids	Vertical and little circumferential	Moderate	Moderate	
iv)	Mixing immiscible liquids:				
	a) Thin liquids	Vertical	Moderate	High	Constant power per unit volume
	b) Medium liquids	Vertical	Moderate	High	
	c) Viscous liquids	Vertical	Small	High	
v)	Emulsifying liquid mixtures:				
	a) Thin liquids	Vertical	Large	High to very high	Constant power per unit volume
	b) Medium liquids	Vertical	Large	High	
	c) Viscous liquids	Vertical	Moderate	High	
vi)	Dispersing gases in liquids	Vertical	Large	High	Constant power per unit volume
vii)	Mixing pastes	Vertical and circumferential	Moderate	Moderate	Constant power per unit volume
viii)	Dispersing agglomerated solids	Vertical and circumferential	Large	Moderate or High	Constant power per unit volume

## 7.4 General Considerations for Selection of Impellers

The following considerations shall be borne in mind for the power selection of the impeller.

### 7.4.1 Baffles

Baffles have the effect of reducing mass flow and increasing turbulence. The formation of vortex is prevented as circumferential flow is suppressed. They are useful where the application requires high turbulence and capable of absorbing high power at relatively low speeds of rotation.

### 7.4.2 Speed of rotation

The tip speeds of all impellers are nearly same for the same agitating effects except in the case of propellers and anchors. Consequently, for a given effect, smaller agitator needs to be run at higher speeds and if small agitators are desired the effects of higher speed on erosion, bearing wear, gland difficulties, vibration, and allied effects should be tolerated.

### 7.4.3 Impeller size

For the same vessel a large agitator operating at low speed produces relatively more mass flow and less turbulence than a smaller but geometrically similar agitator which operates at high speeds and transmits the same power.

### 7.4.4 Number of impellers

Large filling ratios are not recommended but where used should in general have one impeller for each vessel diameter of liquid depth.

### 7.4.5 Power and viscosity

Power level required increased with viscosity of liquid for the same mixing effect.

### 7.4.6 Impeller speed and viscosity

In general it is better to use large impellers at lower speeds as viscosity increases.

### 7.4.7 Immiscible liquids

In agitating immiscible liquids initially in two layers, the impeller must be kept near the interface.

### 7.4.8 Gas dispersion

Gases to be dispersed in liquids by mechanical agitation should be fed from underneath the centre of the impeller.

## 7.5 Selection of Impeller Type

The specific characteristics of commonly used impellers with and without baffles are described in [Table 4](#). Having selected the required conditions for a specific operation from [Table 3](#), the suitable impeller to achieve these conditions may be identified from [Table 4](#).

### 7.5.1 Practical Limitations of Impellers

The following practical limitations regarding impellers should not be overlooked in selection and design of impellers:

- It is difficult to construct anchors to operate at high speeds (that is greater than a tip speed of 300 m/min or to make anchors for vessels exceed 2 800 mm diameter);
- Gate type impellers are not usually desirable for mixing in vessels of less than 1 800 mm diameter. The extra application compared with an anchor or flat paddle is not worthwhile;
- Propellers and other high speed impellers should not be used in high viscosity liquids for general agitation, since their effect rapidly falls with distance from the impeller and causing excessive power loss; and
- The various impellers referred below generally should not be used with viscosities exceeding the value shown against them:

Flat paddle	$1 \times 10^6$ cP
Turbine	$2 \times 10^5$ cP
Propeller	$3 \times 10^3$ cP
Plate	$5 \times 10^5$ cP
Vaned disc	$5 \times 10^3$ cP
Anchor	$7 \times 10^5$ cP
Gate	$1 \times 10^5$ cP

NOTE — In metric (SI) units, 1 cP (centipoise) = 1 mPa·s (millipascal-second)

## 8 SCALING UP

**8.1** For scaling up the results obtained on experimental basis, the same liquid should be used in the small and large scale vessels and also the vessels and impellers should be geometrically similar. The two typical bases used for scaling up the experimental results are:

- Constant impeller tip speed; and
- Constant power input per unit volume.

**Table 4 Choice of Impellers**

(Clause 7.5)

Sl No.	Direction of Mass Flow	Baffles	Impeller	Turbulence	Mass Flow	Remarks		
(1)	(2)	(3)	(4)	(5)	(6)	(7)		
i)	Vertical	Yes	Paddle	Moderate	Small	Mass flow increases with increase in impeller tip speed		
				High	Moderate to large			
				Very high	Very large			
			Turbine	Moderate	Small			
				High	Moderate to large			
				Very high	Very large			
			Propeller (with or without draft tube)	High	Moderate to large			
			Plate	Moderate	Small			
				High	Moderate to large			
				Very high	large			
			Vaned disc	Moderate	Small to moderate			
				High	Moderate to large			
Very high	Large							
ii)	Vertical and little circumferential	No	Propeller	Low	Small to moderate			
				Moderate	Moderate to large			
			Propeller and draft tube	Low	Moderate			
				Moderate	Moderate to large			
iii)	Vertical and circumferential	No	Paddle	Low	Small			
				Moderate	Moderate to very large			
			Turbine	Low	Small			
				Moderate	Moderate to large			
			Plate	Low	Small			
				Moderate	Moderate to very large			
			iv)	Circumferential	No	Anchor	Low	Small to moderate
							Moderate	Large to very large
Gate	Low	Small to moderate						
	Moderate	Moderate to very large						

It is considered that no general choice may be made between the above two bases of scaling up and that each type of duty should be dealt with individually. The duties, however, may be divided between these two methods on the following general principles:

- a) Where the duty demands a similar flow pattern with similar velocities, constant tip speed is recommended; and
- b) Where the duty requires vigorous liquid movement, constant power input per unit volume is recommended.

**8.2** If the category cannot be decided, it is safer to use the basis of constant power per unit volume.

**8.3** For specific operations, the recommended basis for scaling up is given in [Table 3](#).

## 9 GUIDELINES ON POWER ASSESSMENT

**9.1** The power required for agitation shall be considered mainly based on the following two aspects:

- a) The power required under normal operating conditions; and
- b) The power need to cover start-up conditions and peak loads.

**9.2** The power required under normal operating conditions constitutes the sum of the following:

- a) The power required by the impeller under normal operating conditions;
- b) Gland losses; and

- c) Losses in the driving system.

### **9.2.1 Power Required by the Impeller under Normal Operating Conditions**

The power required by the impeller may be computed based on the physical properties of fluids involved, size and shape of vessel, type, size and speed of impeller and nature of fittings involved in the vessel. The actual method of computation of power required by the impeller is not covered by this standard.

### **9.2.2 Gland Losses**

It is found in practice that the power loss in gland varies from less than 0.3 kW for the small impeller shafts up to 3 kW for the larger. Where no relevant experience is available, as a rough approximation the gland losses may be taken as 10 percent of the agitator power consumption, or 0.3 kW, whichever is greater.

### **9.2.3 Drive Loss**

The power loss in a gear box is a function of the rated power capacity of the gear box. Operation at low loads causes a considerable drop in efficiency due to lower working temperature. It is, therefore, usual to allow 20 percent of the maximum input rating as the gear box and V-belt drive loss. Where no gear box is used 5 percent of the horse power required by the agitator may be taken as losses in drive.

### **9.3 Power Needed to Cover up, Start up and Peak Loads**

Factors like the presence of cold lubricant in the gear box at the time of starting, the possibility of solid settling out, addition of new materials into the vessels during operation which exists only during starting or during unusual operation conditions may need additional power from the motor to cope up. Hence, the calculated power needed under normal operating conditions shall be suitably augmented while arriving at the motor capacity to ensure that the motor is capable of dealing with the heaviest loads likely to occur during start up and unusual operating conditions in practice.

## **10 DRIVE AND BEARING ARRANGEMENTS**

### **10.1 Drive**

All impellers should be independently driven by a standard electric motor of the vertically or horizontally mounted type. For speed reduction, a suitable drive from the motor to the gear box is recommended to enable standard gear box ratios to

be used, and to give some degree of flexibility in impeller speeds after installation. For impellers operating at high speeds the required speed reduction may be obtained by the drive alone. Where the agitator shaft passes through a stuffing box or a seal, the drive should be mounted on a rigid body fixed to the top of the vessel to minimize differential movement. Wherever a drive is used, the driving motor itself should be mounted on slide rails so that adjustments may be made to the drive for small speed adjustments. Alternatively gear boxes fitted with a hinged-motor mounting on top for this purpose shall be used.

### **10.2 Gear Box**

The size of the gear box should be at least equivalent to the rating of the motor being used and should be 24 h rating type.

### **10.3 Couplings and Bearings**

The economical method of supporting the impeller shaft would be to use a gear box carrying bearing to accommodate the bending and thrust loads of the impeller shafts, the impeller shaft being rigidly coupled to the output shaft of the gear box. This arrangement is quite suitable for use with shaft passing through stuffing box designed for low pressure duties or where a steady bearing is fitted inside the vessel. However, for installations with long impeller shafts, or where the load is such that bearings are required on the shaft, or where deep stuffing boxes have to be used like in high pressure agitator vessels like auto-claws, it is preferable to fit bearings on the shaft immediately above the stuffing box and a steady bearing inside the vessel below the stuffing box. In such cases the impeller shaft shall be connected to the gear box by a flexible coupling. Coupling between the gear output and impeller shafts may be of any conventional design. For corrosive service it is preferable to arrange couplings between drive and impeller shaft, outside the vessel, even though this entails longer shafts and may necessitate additional bearings.

### **10.4 Glands and Bushes**

Gland should be easily accessible for removal of packing and repacking and where lantern rings are provided, care should be taken to see that they do not operate as a bearing. In high temperature service the gland should be raised sufficiently high above the vessel for ease of cooling. Normally no bearing bush is necessary for pressure application up to 20 kg/cm<sup>2</sup> and where the impeller shaft is robust with its bearings fitted near enough to the stuffing box. For high pressure service or where particularly high standard of performance is demanded from the gland, a bush in the base of the stuffing box is

desirable. Mechanical seals may be used in place of the glands in the agitator vessels. However, when mechanical seals are employed correct alignment and rigidity of the shaft shall be ensured for the proper functioning of the seals.

## 11 MECHANICAL DESIGN

**11.1** Design of vessels, flanges and others shall be made in accordance with IS 2825.

### 11.2 Guidelines for the Design of Agitator Shaft

The stresses that would be included in the agitator shafts are considerably higher than the design torque at normal operating conditions may induce due to various reasons mentioned below. To avoid functional damage and to ensure satisfactory service, the shaft should be designed based on the criteria given below, using the appropriate design formulae.

#### 11.2.1 Starting Torque

During starting conventional types of electric motors, the starting torque is more than the full load rated motor torque. To avoid undue distortion in the shaft due to starting torque, the shaft should be designed to resist 2.5 times the motor rated torque as pure torque without exceeding the safe working stress of the shaft material.

#### 11.2.2 Stalling of Impeller

There is also a possibility of the impeller being checked in situations like addition of materials into the vessel by tipping bags. In such stalled conditions the impeller shaft should not fail before the overload protection of the motor operated. A method of design, found successful, is to make the shaft sufficiently strong to withstand, without exceeding the yield stress of the material, the stresses which

would be set up if the agitator blades were jammed at a point 75 percent of its length from the shaft. The torque prevailing under stalled conditions may be taken as 1.5 times and 2.5 times the motor rated torque for shafts of light duty and heavy duty respectively. Low speed impellers, well clear off from vessel walls or baffles, and in vessels where no solids are charged or precipitated and where the application needs less power input per unit volume are called light duty applications and the rest are high duty applications.

#### 11.2.3 Fouling Installed Conditions

The shafts should be designed so as to be rigid enough and should not deflect to an extent as to cause fouling of the vessel walls, baffles or any other internal fittings when jammed.

#### 11.2.4 Balancing

The tolerance on straightness of shafts, symmetry of the impeller and general accuracy need to be progressively tightened as speeds and power increase. Static balancing is recommended for shaft and impeller assemblies over 2.5 metres long and operating above 100 rpm, and dynamic balancing for shaft and impeller assemblies over 3.7 metres long and operating above 150 rpm.

#### 11.2.5 Critical Speed

The shaft, normally should not run within 30 percent of its critical speed, but when dynamically balanced this limit may be reduced to 15 percent.

#### 11.2.6 Shaft Sizes

To avoid the use of irrational and innumerable shaft sizes and to avoid difficulties in procuring associated parts like bearings, bushes and seals, shaft diameters should be in accordance with [Annex A](#).

## ANNEX A

(Clause [11.2.6](#))

## RECOMMENDED SHAFT DIAMETER

SI No.	Preferred	Choice 2	Preferred	Choice 2
(1)	(2)	(3)	(4)	(5)
i)	<b>20</b>	16	<b>80</b>	75
		18		80
		20		
ii)	<b>25</b>	21	90	85
		22		90
		24		
		25		
iii)	<b>30</b>	26	<b>100</b>	95
		28		100
		30		
iv)	35	32	110	105
		34		110
		35		
v)	<b>40</b>	36	<b>125</b>	120
		38		125
		40		
vi)	<b>45</b>	42	140	130
		45		140
vii)	<b>50</b>	48	<b>160</b>	150
		50		160
viii)	55	53	180	170
		55		180
ix)	<b>60</b>	56	<b>200</b>	190
		60		
x)	70	63		
		67		
		70		

NOTE — The values in bold figures are from R10 series of preferred numbers, suitably rounded off and shall be chosen whenever possible.

## ANNEX B

(Foreword)

## COMMITTEE COMPOSITION

Chemical Engineering Plants and Related Equipment Sectional Committee, MED 17

<i>Organization</i>	<i>Representative(s)</i>
CSIR - Indian Institute of Petroleum, Dehradun	DR MRITUNJAY KUMAR SHUKLA ( <i>Chairperson</i> )
Auma India Private Limited, Bengaluru	SHRI YASHWANT M. JANNU
Bharat Heavy Electrical Limited, New Delhi	SHRI Y. SRINIVASA RAO SHRI ABHISHEK KUMAR PANDEY ( <i>Alternate I</i> ) SHRI RAJESH RANJAN ( <i>Alternate II</i> ) SHRI SUBHASHISH GUPTA ( <i>Alternate III</i> )
Bharat Petroleum Corporation Limited Corporate Research and Development Centre, Greater Noida	MS ISHA KHULLAR SHRI VINOD KUMAR ( <i>Alternate</i> )
Blast Carboblocks Private Limited, Mumbai	SHRI DHAWAL SAXENA
Chemtrols Industries Private Limited, New Delhi	SHRI P. KRISHNA KUMAR
Confederation of Indian Industry, New Delhi	SHRI NANDAKUMAR KALATH SHRI ABHILASH UTTAM ( <i>Alternate</i> )
Directorate General Factory Advice Service and Labour Institutes, Mumbai	SHRI TANOJ CHANDAN SHRI KUNAL SHARMA ( <i>Alternate</i> )
Engineers India Limited, Gurugram	SHRI HASMUKH K. PARMAR SHRI MRAGANG SHEAKHAR ( <i>Alternate</i> )
Fab-Tech Works And Constructions Private Limited, Mumbai	SHRI AASHISH JAYPRAKASH LAKHANI SHRI PRADEEP GAWATE ( <i>Alternate</i> )
GMM Pfaudler Limited, Anand	SHRI DHIREN PANCHAL SHRI SATVIK PATEL ( <i>Alternate</i> )
Kejriwal Casting Limited, Kolkata	SHRI SANDEEP KEJRIWAL SHRI SABARNA ROY ( <i>Alternate</i> )
L&T Valves, Chennai	SHRI ROHIT SHARMA SHRI SURIYANARAYANAN ( <i>Alternate</i> )
MECON Limited, Ranchi	SHRI YOGENDRA KUMAR SINGH SHRI ARVIND BHUSHAN ( <i>Alternate</i> )
Nuclear Power Corporation of India Limited, Mumbai	SHRI CHANDRAKANT RAJARAM KAKADE SHRI ARUNAVA SINHA ( <i>Alternate</i> )
Project and Development India Limited, Noida	SHRI SANJIV KUMAR MISHRA SHRI RAJEEV RANJAN KUMAR ( <i>Alternate</i> )
Tata Consulting Engineers Limited, Navi Mumbai	SHRI SHIVNARAYAN PAREEK SHRI SHIREESH S. SWAMI ( <i>Alternate</i> )
BIS Directorate General	SHRI K. VENKATESWARA RAO, SCIENTIST 'F'/SENIOR DIRECTOR AND HEAD (MECHANICAL ENGINEERING) [REPRESENTING DIRECTOR GENERAL ( <i>Ex-officio</i> )]

*Member Secretary*  
MS NEHA THAKUR  
SCIENTIST 'C'/DEPUTY DIRECTOR  
(MECHANICAL ENGINEERING), BIS







## Bureau of Indian Standards

BIS is a statutory institution established under the *Bureau of Indian Standards Act, 2016* to promote harmonious development of the activities of standardization, marking and quality certification of goods and attending to connected matters in the country.

### Copyright

BIS has the copyright of all its publications. No part of these publications may be reproduced in any form without the prior permission in writing of BIS. This does not preclude the free use, in the course of implementing the standard, of necessary details, such as symbols and sizes, type or grade designations. Enquiries relating to copyright be addressed to the Head (Publication & Sales), BIS.

### Review of Indian Standards

Amendments are issued to standards as the need arises on the basis of comments. Standards are also reviewed periodically; a standard along with amendments is reaffirmed when such review indicates that no changes are needed; if the review indicates that changes are needed, it is taken up for revision. Users of Indian Standards should ascertain that they are in possession of the latest amendments or edition by referring to the website-[www.bis.gov.in](http://www.bis.gov.in) or [www.standardsbis.in](http://www.standardsbis.in).

This Indian Standard has been developed from Doc No.: MED 17 (22765).

### Amendments Issued Since Publication

Amend No.	Date of Issue	Text Affected

## BUREAU OF INDIAN STANDARDS

### Headquarters:

Manak Bhavan, 9 Bahadur Shah Zafar Marg, New Delhi 110002

Telephones: 2323 0131, 2323 3375, 2323 9402

Website: [www.bis.gov.in](http://www.bis.gov.in)

### Regional Offices:

Central : 601/A, Konnectus Tower -1, 6<sup>th</sup> Floor,  
DMRC Building, Bhavbhuti Marg, New  
Delhi 110002

Telephones

{ 2323 7617

Eastern : 8<sup>th</sup> Floor, Plot No 7/7 & 7/8, CP Block, Sector V,  
Salt Lake, Kolkata, West Bengal 700091

{ 2367 0012  
{ 2320 9474

Northern : Plot No. 4-A, Sector 27-B, Madhya Marg,  
Chandigarh 160019

{ 265 9930

Southern : C.I.T. Campus, IV Cross Road, Taramani, Chennai 600113

{ 2254 1442  
{ 2254 1216

Western : 5<sup>th</sup> Floor/MTNL CETTM, Technology Street, Hiranandani Gardens,  
Powai, Mumbai 400076

{ 2570 0030  
{ 2570 2715

**Branches :** AHMEDABAD, BENGALURU, BHOPAL, BHUBANESHWAR, CHANDIGARH, CHENNAI, COIMBATORE, DEHRADUN, DELHI, FARIDABAD, GHAZIABAD, GUWAHATI, HARYANA (CHANDIGARH), HUBLI, HYDERABAD, JAIPUR, JAMMU, JAMSHEDPUR, KOCHI, KOLKATA, LUCKNOW, MADURAI, MUMBAI, NAGPUR, NOIDA, PARWANOO, PATNA, PUNE, RAIPUR, RAJKOT, SURAT, VIJAYAWADA.