

---

---

डबल एक्शन प्रूनिंग आरी — विशिष्टि  
( तीसरा पुनरीक्षण )

**Double Action Pruning Saw —  
Specification**  
( *Third Revision* )

ICS 65.070.40

© BIS 2024



भारतीय मानक ब्यूरो  
BUREAU OF INDIAN STANDARDS  
मानक भवन, 9 बहादुर शाह ज़फर मार्ग, नई दिल्ली - 110002  
MANAK BHAVAN, 9 BAHADUR SHAH ZAFAR MARG  
NEW DELHI - 110002  
[www.bis.gov.in](http://www.bis.gov.in) [www.standardsbis.in](http://www.standardsbis.in)

## FOREWORD

This Indian Standard (Third Revision) was adopted by the Bureau of Indian Standards, after the draft finalized by the Agricultural Machinery and Equipment Sectional Committee had been approved by the Food and Agriculture Division Council.

The pruning saw is one of the essential hand tools, extensively used in tea, coffee and rubber plantation for trimming those twigs and branches which are inconvenient to cut with shears, secateurs or pruning knives. It is also used in orchards and sometimes in vegetable gardens. Nowadays, double action pruning saws are available which combine forward and reverse cutting action. The double action pruning saw with special tooth form results in more efficient cutting, lesser force with higher volume removal of saw dust in each stroke.

This standard was first published 1965 and it was revised in 1982 to include certain essential dimensions. Subsequently, the standard was again revised in 1991 to incorporate the requirements of pruning saw used for pruning of branches of a tree. The revision of this standard incorporates the following modifications:

- a) The double action pruning saw has replaced the light and heavy duty pruning saw which were covered in earlier version of this standard as per the usage and latest manufacturing practices. The title of the standard has been modified accordingly from 'Pruning saw' to 'Double action pruning saw';
- b) Double action pruning saw has been classified into two types based on teeth;
- c) Raw material requirements for saw blade and handle have been updated as per latest manufacturing practices; and
- d) Hardness range has been updated.

The figures given in this standard are meant only for illustration and should not be considered as suggestive of any standard design.

In revision of this standard, considerable assistance has been derived from the information provided by Agricultural Machinery Manufacturers Association, Pune, India.

The composition of the Committee responsible for the formulation of this standard is given in [Annex B](#).

For the purpose of deciding whether a particular requirement of this standard is complied with, the final value, observed or calculated, expressing the result of a test, or analysis shall be rounded off in accordance with IS 2 : 2022 'Rules for rounding of numerical values (*second revision*)'. The number of significant places retained in the rounded off value should be the same as that of the specified value in this standard.

*Indian Standard*

## DOUBLE ACTION PRUNING SAW — SPECIFICATION

( Third Revision )

### 1 SCOPE

This standard specifies material dimensions and other requirements for double action pruning saw.

### 2 REFERENCES

The standards listed in [Annex A](#) contain provisions, which through reference in this text, constitute provision of this standard. At the time of publication, the editions indicated were valid. All standards are subject to revision, and parties to agreements based on this standard are encouraged to investigate the possibility of applying the most recent edition of these standards.

### 3 TERMINOLOGY

For the purpose of this standard, the following definitions shall apply.

**3.1 Curved Edge** — A saw blade, on which the toothed edge is concave.

**3.2 Flat Ground** — A saw blade, which is ground so as to be of the same thickness across the entire width, from the toothed edge to the back edge.

**3.3 Skew Back** — A saw blade, on which the edge opposite to the toothed edge is concave.

**3.4 Straight Edge** — A saw blade, on which the toothed edge is straight.

### 4 GRADES

The double action pruning saws shall be of the following two grades and types:

#### 4.1 Grade 1

- a) Folding handle (see [Fig. 1](#) and [Fig. 2](#)):
  - 1) Type 1 — with relieving groove teeth; and
  - 2) Type 2 — without relieving groove (continuous teeth).

#### 4.2 Grade 2

- a) Fixed handle (see [Fig. 3](#)):
  - 1) Type 1 — with relieving groove teeth; and
  - 2) Type 2 — without relieving groove (continuous teeth).

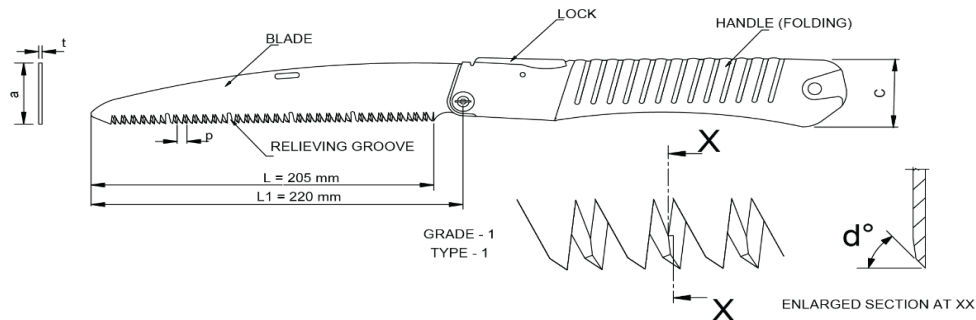

FIG. 1A EXAMPLE 1

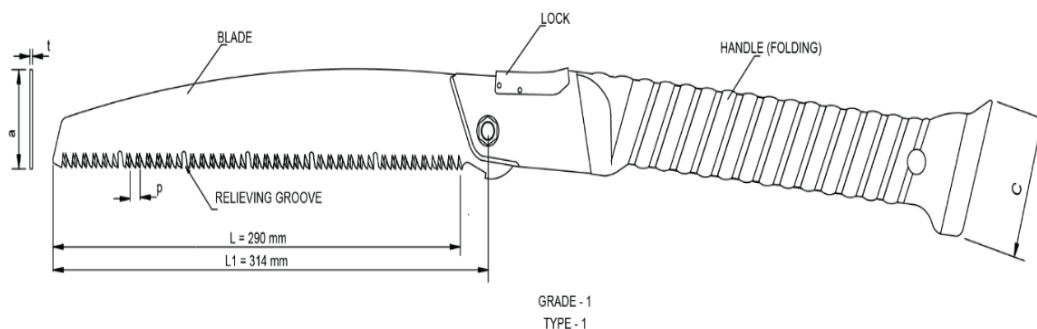

FIG. 1B EXAMPLE 2

FIG. 1 TYPICAL EXAMPLE OF DOUBLE ACTION PRUNING SAW WITH FOLDING HANDLE (GRADE-1, TYPE-1)

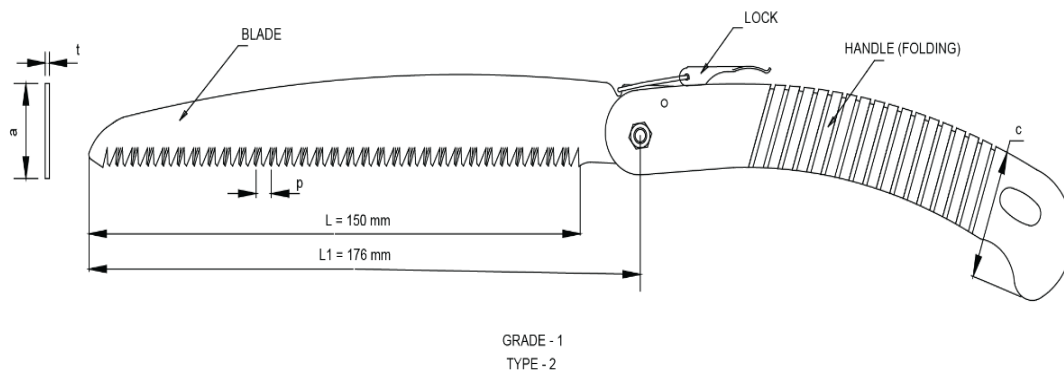

FIG. 2 TYPICAL EXAMPLE OF DOUBLE ACTION PRUNING SAW WITH FOLDING HANDLE  
(GRADE-1, TYPE-2)

## 5 MATERIALS

### 5.1 Blade of Double Action Pruning Saw

For the double action pruning saw, the saw blades shall be manufactured from a suitable steel having a carbon content of not less than 0.7 percent. Suitable steels that may be used for this purpose are C70, C75, C80, C85 [see IS 1570 (Part 2/Sec 1)] or SK5 grade of steel with a maximum sulphur and phosphorus content of 0.05 percent each.

### 5.2 Handle

For the double action pruning saw, the saw handles shall be made of teak wood or mild steel handle with nylon/plastic/PVC sleeve (see IS 9766) or plastic handle (see IS 15226). Suitable locking arrangement shall be provided for folding handle pruning saw.

## 6 HARDNESS

The saw blades shall be heat-treated to have a hardness in range of 48 to 55 HRC [see IS 1586 (Part 1)]. The hardness shall be measured anywhere on the surface, preferably as near to the sawing edge as possible.

## 7 DIMENSIONS

The main and critical dimensions of the double action pruning saws shall be as given in [Table 1](#), [Table 2](#) and [Table 3](#). The connotations for the symbols used in the tables are as per figures.

## 8 OTHER REQUIREMENTS

**8.1** The saw shall be stamped and annealed before cutting the teeth.

**8.2** The teeth shall be alternatively set on either side of the blade.

**8.3** The handle shall be centrally slit. The width of slot shall not be greater than necessary to receive the blade tang.

**8.4** In case of folding handle pruning saw, the steel handle shall be fixed with the blade using one screw or rivet and locking pin. In case of fixed handle pruning saw, the steel handle shall be fixed with the blade using two screws or rivets. Riveting is not required for PVC handle.

**8.5** A blade cover made of rexin, canvass or plastics should be provided for safe handling of saw.

### 8.6 Teeth Grinding

Teeth profile should be ground on a suitable grinding machine with the help of special fixture or through some indigenously made special purpose machine.

#### 8.6.1 Type-1

Double action saw with relieving groove shall be formed by grinding as per [Table 1](#) and [Table 3](#).

#### 8.6.2 Type-2

Double action saw with continuous teeth shall be formed by grinding as per [Table 1](#), [Table 2](#) and [Table 3](#).

## 9 TESTS

### 9.1 Cutting Test/Performance Test

**9.1.1** The cutting edge of the pruning saw shall be tested by sawing 600 branches of 25 mm diameter or near about diameter of green wood. Upon completion of the test the saw teeth shall not show any sign of damage.

**9.1.2** Each saw, when properly sharpened and set, should make clean and effortless cuts without bending when tested on well-seasoned Indian oak or an appropriate hardwood substitute. This applies to both cutting along and across the grain.

### 9.2 Bend Test

The entire length of the blade shall be made to lie on the periphery of a 150 mm radius segment and kept for one minute. The blade shall not show any sign of damage during test or take any permanent set when released.

### 9.3 Straightness Test

When checked with the aid of a straight edge, or any angle protector, blade shall be visually straight and free from twist.

## 10 WORKMANSHIP AND FINISH

**10.1** The blade shall be ground flat.

**10.2** The tooth edge shall be flat.

**10.3** The components shall be free from cracks, pits splits and other visual defects.

**10.4** The handle shall be finished smooth. It shall be suitably gripped tight to prevent slippage in operation.

**10.5** The blade shall be smeared all over with a mineral jelly or with any other rust preventive paint (*see* IS 1153). The wooden handle may be varnished.

## 11 PACKING AND MARKING

### 11.1 Marking

The saw shall be marked clearly with the following information on its blade/handle:

- Manufacturer's name or recognized trademark, if any;
- Grade and type;
- Nominal size; and
- Batch or code number.

### 11.2 Packing

Because of highly sharp edges the exposed metallic parts shall be packed with proper thick paper or plastic sheet, such as blister type or pouch type of packing to prevent any accidental damage of the product or injury to any human being.

### 11.3 BIS Certification Marking

The product(s) conforming to the requirements of this standard may be certified as per the conformity assessment schemes under the provisions of the *Bureau of Indian Standards Act, 2016* and the Rules and Regulations framed thereunder, and the products may be marked with the Standard Mark.

## 12 SAMPLING FOR LOT ACCEPTANCE

Unless otherwise agreed to between the purchaser and the supplier the sampling criteria for conformity of pruning saw shall be done in accordance as per IS 7201 (Part 1).

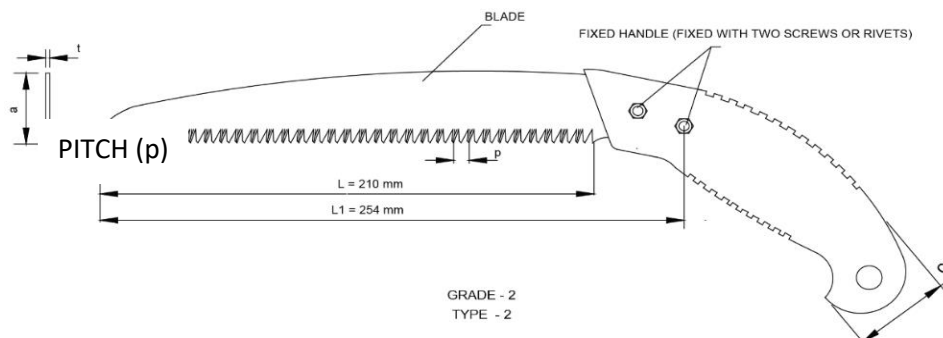

FIG. 3 TYPICAL EXAMPLE OF DOUBLE ACTION PRUNING SAW WITH FIXED HANDLE (GRADE-2, TYPE-2)

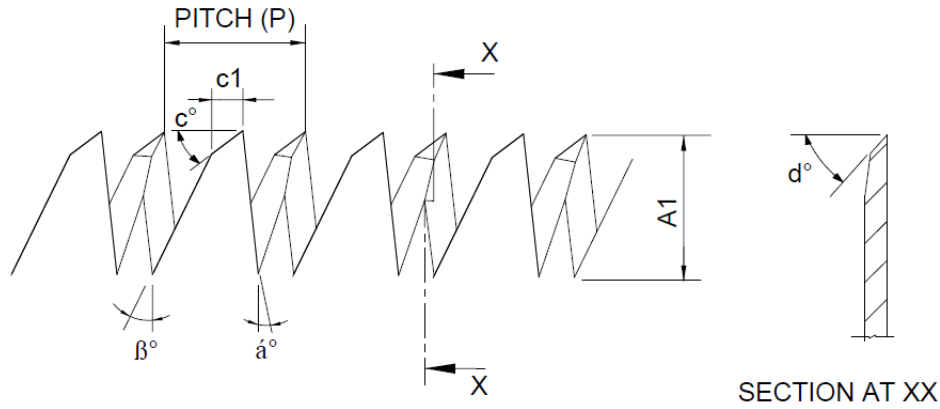

FIG. 4 DETAIL TOOTH PROFILE OF SAW BLADE

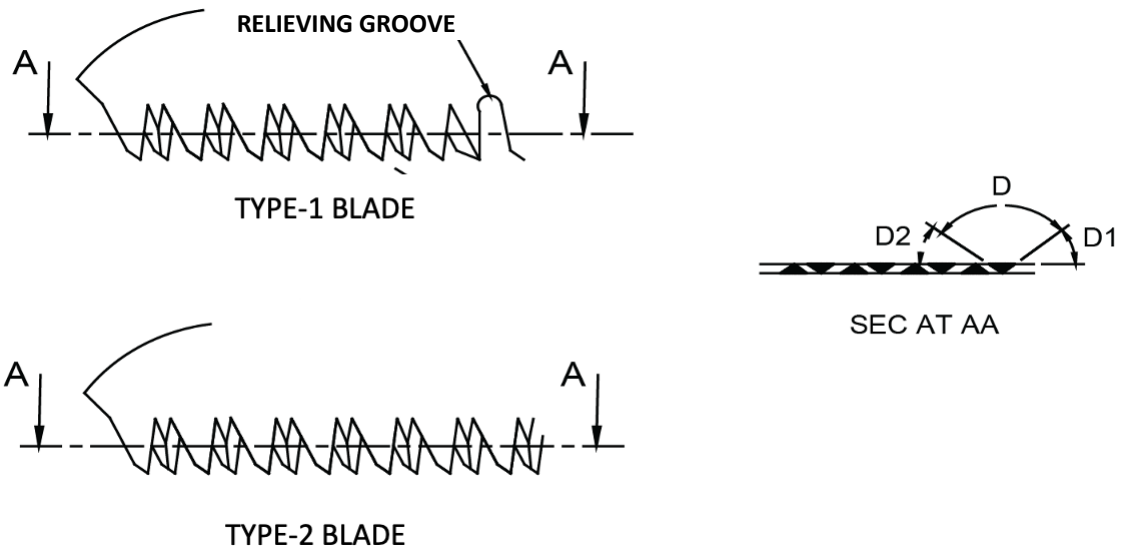

FIG. 5 SAW BLADE WITH AND WITHOUT RELIEVING GROOVE

**Table 1 The Main Dimensions of the Double Action Pruning Saws (Grade-1)**

(Clauses 7, 8.6.1 and 8.6.2)

(All dimensions are in millimetres.)

Sl No.	Types	Nominal Size, L Grade-1	Total Length of Blade, L1 Grade-1	Width of Blade, a Grade-1 ± 3	Width of Handle, C Grade-1	Thickness, t Grade-1 ± 0.04	Pitch, p	Handle Fastening Grade-1 1 Screw, 1 Lock Pin	Referred Figures
(1)	(2)	(3)	(4)	(5)	(6)	(7)	(8)	(9)	(10)
i)	Type 1	205	220	36	38	1.0	5.0	Yes	see <a href="#">Fig. 1A</a>
		290	314	44	48	1.0	5.0	Yes	see <a href="#">Fig. 1B</a>
iii)	Type 2	150	176	30	45	0.8	9.0	Yes	see <a href="#">Fig. 2</a>

**Table 2 The Main Dimensions of the Double Action Pruning Saws (Grade-2)**(Clauses [7](#), [8.6.1](#) and [8.6.2](#))

(All dimensions are in millimetres.)

Sl No.	Types	Nominal Size (L) Grade-2	Total Length of Blade, L1 Grade-2	Width of Blade, a Grade-2 $\pm 3$	Width of Handle, C Grade-2	Thickness, t Grade-2 $\pm 0.04$	Pitch, P	Handle Fastening Grade-2 2 Screws	Referred Figures
(1)	(2)	(3)	(4)	(5)	(6)	(7)	(8)	(9)	(10)
i)	Type 2	210	254	35	40	0.8	9.0	Yes	see <a href="#">Fig. 3</a>

**Table 3 Critical Dimensions for Double Action Pruning Saws**(Clauses [7](#), [8.6.1](#), [8.6.2](#), [Fig. 4](#) and [Fig. 5](#))

(All dimensions are in millimetres.)

Sl No.	Characteristic	Min	Max
(1)	(2)	(3)	(4)
i)	$\alpha^\circ$	5.5	6.5
ii)	A1	5	8
iii)	$\beta^\circ$	15	16
iv)	$c^\circ$	23	25
v)	C1	1	2
vi)	$d^\circ$	34	-
vii)	P	5	9
viii)	D1	45	-
ix)	D2	45	-

## ANNEX A

(Clause 2)

## LIST OF REFERRED STANDARDS

<i>IS No.</i>	<i>Title</i>	<i>IS No.</i>	<i>Title</i>
IS 1153 : 2021	Temporary corrosion preventives, hard film, solvent deposited — Specification ( <i>third revision</i> )	IS 7201 (Part 1) : 1987	Methods of sampling of agricultural machinery and equipment: Part 1 Hand-tools and hand-operated/animal-drawn equipment ( <i>first revision</i> )
IS 1570 (Part 2/ Sec 1) : 1979	Schedules for wrought steels: Part 2 Carbon steels (unalloyed steels), Section 1 Wrought products (other than wires) with specified chemical composition and related properties ( <i>first revision</i> )	IS 9766 : 1992	Flexible PVC compounds — Specification ( <i>first revision</i> )
IS 1586 (Part 1) : 2018/ISO 6508-1 : 2016	Metallic materials — Rockwell hardness test: Part 1 Test method ( <i>fifth revision</i> )	IS 15226 : 2002	Rigid polyvinyl chloride (PVC) compounds — Specification

To access Indian Standards click on the link below:

[https://www.services.bis.gov.in/php/BIS\\_2.0/bisconnect/knowyourstandards/Indian\\_standards/isdetails/](https://www.services.bis.gov.in/php/BIS_2.0/bisconnect/knowyourstandards/Indian_standards/isdetails/)



## ANNEX B

(Foreword)

## COMMITTEE COMPOSITION

Agricultural Machinery and Equipment Sectional Committee, FAD 11

<i>Organization</i>	<i>Representative(s)</i>
ICAR - Central Institute of Agricultural Engineering, Bhopal	DR C. R. MEHTA ( <b>Chairperson</b> )
Agricultural Machinery Manufacturers Association (AMMA-India), Gandhinagar	DR SURENDRA SINGH SHRI MITUL PANCHAL ( <i>Alternate</i> )
All India Farmers Alliance, New Delhi	DR RAJARAM TRIPATHI SHRIMATI APURVA TRIPATHI ( <i>Alternate</i> )
ASPEE Agro Equipment Private Limited, Mumbai	SHRI JATIN S. PATEL SHRI GANGADHAR VARPE ( <i>Alternate</i> )
Automotive Research Association of India, Pune	SHRI A. AKBAR BADUSHA SHRI GIRISH TANAWADE ( <i>Alternate I</i> ) SHRI GANGARAM AUTI ( <i>Alternate II</i> )
CCS Haryana Agricultural University, Hisar	DR VIJAYA RANI
Central Farm Machinery Training and Testing Institute, Budni	SHRI ANIL KUMAR UPADHYAY SHRI BABUL NATH DIXIT ( <i>Alternate I</i> ) SHRI PARTH LODH ( <i>Alternate II</i> )
CLAAS India Private Limited, Chandigarh	SHRI KRISHNA PRABHAKAR SINGH
CNH Industrial India Private Limited, Pune	SHRI SANTHOSH RAO SHRI SUJIT HINGE ( <i>Alternate</i> )
Consumer Guidance Society of India, Mumbai	SHRI SITARAM DIXIT
Dasmesh Mechanical Works Private Limited, Malerkotla	SHRI SARBJEET SINGH PANESAR SHRI GURDEEP SINGH PANESAR ( <i>Alternate</i> )
ICAR - All India Coordinated Research Project on Ergonomics and Safety in Agriculture, Bhopal	DR SUKHBIR SINGH DR RAHUL R. POTDAR ( <i>Alternate I</i> ) SHRIMATI SWEETI KUMARI ( <i>Alternate II</i> )
ICAR - All India Coordinated Research Project on Farm Implements and Machinery, Bhopal	DR K. N. AGRAWAL
ICAR - All India Coordinated Research Project on Mechanization of Animal Husbandry, Bhopal	DR S. P. SINGH
ICAR - Central Institute of Agricultural Engineering, Bhopal	DR V. P. CHAUDHARY DR U. R. BADEGAONKAR ( <i>Alternate I</i> ) DR DILIP JAT ( <i>Alternate II</i> )
Indian Council of Agricultural Research, New Delhi	DR PANNA LAL SINGH
John Deere India Private Limited, Pune	SHRI ANAND RAJ SHRI CHANDRASHEKHAR DESHMUKH ( <i>Alternate I</i> ) SHRI PRATIK DURAPHE ( <i>Alternate II</i> )
Kerala Agro Machinery Corporation Ltd (KAMCO), Athani	SHRI A. UNNIKRISHNAN SHRI P. C. SAJIMON ( <i>Alternate</i> )
KisanKraft Limited, Bangaluru	SHRI RAVINDRA AGARWAL SHRI ANKIT CHITALIA ( <i>Alternate I</i> ) SHRI SUNIL PRASAD ( <i>Alternate II</i> )

<i>Organization</i>	<i>Representative(s)</i>
Kubota Agricultural Machinery India Private Limited, Faridabad	SHRI ASHOK KUMAR SHRI ASHISH KUMAR MALLARH ( <i>Alternate</i> )
Maharana Pratap University of Agricultural and Technology, Udaipur	DR SANWAL SINGH MEENA
Mahatma Phule Krishi Vidyapeeth, Rahuri	DR SACHIN MADHUKAR NALAWADE SHRI VIKRAM PARASHARAM KAD ( <i>Alternate I</i> ) DR AVDHUT ASHOK WALUN ( <i>Alternate II</i> )
Mahindra and Mahindra Limited, Mumbai	SHRI PRADEEP SHINDE
Ministry of Agriculture, Department of Agriculture, New Delhi	DR V. N. KALE SHRI ARVIND N. MESHARAM ( <i>Alternate</i> )
National Innovation Foundation, New Delhi	SHRI RAKESH MAHESHWARI SHRI MAHESH PATEL ( <i>Alternate</i> )
National Institute of Plant Health Management, Hyderabad	DR VIDHU KAMPURATH P. SHRI MUTYALA UDAYA ( <i>Alternate</i> )
North Eastern Region Farm Machinery Training and Testing Institute, Biswanath Chariali	DR P. P. RAO SHRI S. G. PAWAR ( <i>Alternate I</i> ) SHRI KHAGENDRA BORA ( <i>Alternate II</i> )
Northern Region Farm Machinery Training and Testing Institute, Hisar	DR MUKESH JAIN SHRI SANJAY KUMAR ( <i>Alternate</i> )
Power Tillers Manufacturers Association, Kolkata	SHRI A. R. GANESH KUMAR
Punjab Agricultural University, Ludhiana	DR MAHESH KUMAR NARANG DR RAJESH GOYAL ( <i>Alternate I</i> ) SHRI APOORV PRAKASH ( <i>Alternate II</i> )
Southern Region Farm Machinery Training and Testing Institute, Anantpur	DR B. M. NANDEDE
Tamil Nadu Agricultural University, Coimbatore	DR R. KAVITHA DR A. SURENDRA KUMAR ( <i>Alternate I</i> ) DR A. P. MOHAN KUMAR ( <i>Alternate II</i> )
Tirth Agro Technology Private Limited 'Shaktiman', Rajkot	SHRI PARAG DEVIDAS BADGUJAR SHRI V. AUDHI NARAYAN REDDY ( <i>Alternate</i> )
Tractor and Mechanization Association, New Delhi	SHRI PHILIP KOSHY SHRI VEENIT NEGI ( <i>Alternate I</i> ) SHRIMATI DEVYANI ( <i>Alternate II</i> )
Tube Investments Clean Mobility Private Limited, Chennai	SHRI ABHISHEK SINHA SHRI S. O. TYAGI ( <i>Alternate</i> )
Voluntary Organisation in Interest of Consumer Education (VOICE), New Delhi	SHRI B. K. MUKHOPADHYAY
In Personal Capacity (201, Memnon Tower, Omaxe the Nile, Sector 49, Sohna Road, Gurugram - 122018)	SHRI VIVEK GUPTA
BIS Directorate General	SHRIMATI SUNEETI TOTEJA, SCIENTIST 'F'/SENIOR DIRECTOR AND HEAD (FOOD AND AGRICULTURE) [REPRESENTING DIRECTOR GENERAL ( <i>Ex-officio</i> )]

*Member Secretary*  
SHRI VIKRANT CHAUHAN  
SCIENTIST 'B'/ASSISTANT DIRECTOR  
(FOOD AND AGRICULTURE), BIS

## Panel to Formulate and Review Indian Standards on Gardening and Forestry Tools and Agricultural Implements, FAD 11/P 3

<i>Organization</i>	<i>Representative(s)</i>
Agricultural Machinery Manufacturers Association (AMMA-India), Gandhinagar	DR SURENDRA SINGH ( <b><i>Convener</i></b> )
ASPEE Agro Equipment Private Limited, Mumbai	SHRI JATIN S. PATEL SHRI GANGADHAR VARPE ( <i>Alternate</i> )
Falcon Garden Tools Private Limited, Ludhiana	SHRI GURCHINTAN SINGH DUA
ICAR - Central Institute of Agricultural Engineering, Bhopal	DR DILIP JAT
John Deere India Private Limited, Pune	SHRI CHANDRASHEKHAR DESHMUKH
Mahatma Phule Krishi Vidyapeeth, Rahuri	DR SACHIN MADHUKAR NALAWADE





## Bureau of Indian Standards

BIS is a statutory institution established under the *Bureau of Indian Standards Act, 2016* to promote harmonious development of the activities of standardization, marking and quality certification of goods and attending to connected matters in the country.

### Copyright

BIS has the copyright of all its publications. No part of these publications may be reproduced in any form without the prior permission in writing of BIS. This does not preclude the free use, in the course of implementing the standard, of necessary details, such as symbols and sizes, type or grade designations. Enquiries relating to copyright be addressed to the Head (Publication & Sales), BIS.

### Review of Indian Standards

Amendments are issued to standards as the need arises on the basis of comments. Standards are also reviewed periodically; a standard along with amendments is reaffirmed when such review indicates that no changes are needed; if the review indicates that changes are needed, it is taken up for revision. Users of Indian Standards should ascertain that they are in possession of the latest amendments or edition by referring to the website-[www.bis.gov.in](http://www.bis.gov.in) or [www.standardsbis.in](http://www.standardsbis.in).

This Indian Standard has been developed from Doc No.: FAD 11 (24876).

### Amendments Issued Since Publication

Amend No.	Date of Issue	Text Affected

## BUREAU OF INDIAN STANDARDS

### Headquarters:

Manak Bhavan, 9 Bahadur Shah Zafar Marg, New Delhi 110002

Telephones: 2323 0131, 2323 3375, 2323 9402

Website: [www.bis.gov.in](http://www.bis.gov.in)

### Regional Offices:

Central : 601/A, Konnectus Tower -1, 6<sup>th</sup> Floor,  
DMRC Building, Bhavbhuti Marg, New  
Delhi 110002

Telephones

{ 2323 7617

Eastern : 8<sup>th</sup> Floor, Plot No 7/7 & 7/8, CP Block, Sector V,  
Salt Lake, Kolkata, West Bengal 700091

{ 2367 0012  
2320 9474

Northern : Plot No. 4-A, Sector 27-B, Madhya Marg,  
Chandigarh 160019

{ 265 9930

Southern : C.I.T. Campus, IV Cross Road, Taramani, Chennai 600113

{ 2254 1442  
2254 1216

Western : 5<sup>th</sup> Floor/MTNL CETTM Technology Street, Hiranandani Gardens, Powai,  
Mumbai - 400076

{ 283 25838

**Branches :** AHMEDABAD, BENGALURU, BHOPAL, BHUBANESHWAR, CHANDIGARH, CHENNAI, COIMBATORE, DEHRADUN, DELHI, FARIDABAD, GHAZIABAD, GUWAHATI, HARYANA (CHANDIGARH), HUBLI, HYDERABAD, JAIPUR, JAMMU, JAMSHEDPUR, KOCHI, KOLKATA, LUCKNOW, MADURAI, MUMBAI, NAGPUR, NOIDA, PARWANOO, PATNA, PUNE, RAIPUR, RAJKOT, SURAT, VIJAYAWADA.