

विद्युतीय वाहन चालकता चार्जिंग
प्रणालियाँ

भाग 30 डुअल गन डी सी विद्युतीय वाहन प्रदाय
उपकरण

**Electric Vehicle Conductive
Charging Systems**
**Part 30 Dual Gun d.c. Electric Vehicle
Supply Equipment**

ICS 43.120

© BIS 2024



भारतीय मानक ब्यूरो
BUREAU OF INDIAN STANDARDS
मानक भवन, 9 बहादुर शाह ज़फर मार्ग, नई दिल्ली - 110002
MANAK BHAVAN, 9 BAHADUR SHAH ZAFAR MARG
NEW DELHI - 110002

www.bis.gov.in www.standardsbis.in

FOREWORD

This Indian Standard (Part 30) was adopted by the Bureau of Indian Standards, after the draft finalized by the Electrotechnology in Mobility Sectional Committee and approval of the Electrotechnical Division Council.

This standard provides guidance to industry for setting up charging stations and to the electric vehicle manufactures to prepare the vehicles to charge the batteries from these charging stations.

This standard covers the dual gun d.c. electric vehicle supply equipment for charging electric road vehicles, with a rated supply voltage up to 1 000 V a.c. or up to 1 500 V d.c. and a rated output voltage up to 1 500 V d.c.

Considerable assistance has been obtained from IS 17017 (Part 23) while preparing this standard.

This standard is to be read in conjunction with IS 17017 (Part 1) : 2021.

The composition of the Committee responsible for formulation of this standard is given in [Annex E](#).

For the purpose of deciding whether a particular requirement of this temporary standard is complied with, the final value, observed or calculated expressing the result of a test, shall be rounded off in accordance with IS 2 : 2022 'Rules for rounding of numerical values (*second revision*)'. The number of significant places retained in the rounded off value should be the same as that of the specified value in this standard.

CONTENTS

1	Scope.....	1
2	References.....	1
3	Terminology	1
4	General requirements.....	4
5	Classification	4
6	Charging modes and functions	4
7	Communications	14
8	Protection against Electric Shock.....	14
9	Conductive Electrical interface requirements.....	21
10	Requirements for adaptors	22
11	Cable assembly requirements	22
12	EV Supply equipment constructional requirements and tests.....	22
13	Overload and short circuit protection.....	30
14	Automatic reclosing of protective devices.....	31
15	Emergency switching or disconnect (optional).....	31
16	Marking and Instructions.....	31
101	Specific requirements for d.c. EV Supply equipment.....	32
102	Test requirements.....	41
	Annex A d.c. EV Supply Equipment of System C	45
	Annex B Typical d.c. Charging Systems.....	120
	Annex C Multioutlet (a.c./d.c. Isolated) d.c. EV Supply Equipment	123
	Annex D Communication and Charging Process between d.c. Electric Vehicle Supply Equipment and Electric Vehicle.....	129
	Annex E Committee Composition.....	131
	Table 1 — Data/Message for transmission test.....	8
	Table 2 — Error shutdown trigger timing.....	8
	Table 3 — Control circuit Supply integrity test.....	8
	Table 4 — Touch voltage under normal operation (water wet).....	16
	Table 5 — Touch voltage under single fault conditions (water wet).....	16
	Table 6 — Minimum Protective Measures.....	19
	Table 7 — Sizes of conductors of power Supply cord.....	26
	Table 8 — Cord strain relief pull force.....	26
	Table 9 — Current ripple limit of d.c. EV Supply equipment.....	35
	Table 10 — Values for parameter A, L and R.....	39
	Table 11 — Recommended circuit parameters of the test load.....	43
	Table 12 — d.c. couplers for combined charging system.....	45
	Table 13 — Definition of proximity resistor for configuration FF.....	45
	Table 14 — Message mapping for sequence diagram.....	47
	Table 15 — Example of sequence description.....	48
	Table 16 — Sequence description for normal start up	52
	Table 17 — Sequence description for normal shutdown	56
	Table 18 — Overview of error and emergency shutdown cases.....	58
	Table 19 — Sequence description for d.c. EV Supply equipment and EV initiated error shutdown.....	60
	Table 20 — Sequence description for d.c. EV Supply equipment and EV initiated emergency shutdown.....	63
	Table 21 — Insulation states and d.c. EV Supply equipment reaction based on the measured insulation resistance.....	64
	Table 22 — Exemplary determination if touch current limit is fulfilled by design.....	68
	Table 23 — Values to design the EV and EVSE during pre-charge based on Fig. 52.....	70
	Table 24 — Definition and description of symbols / terms.....	76
	Table 25 — Compliance test for compatibility assessment.....	80
	Table 26 — Compliance test for wake up of d.c. EV Supply equipment by EV.....	81
	Table 27 — Compliance test for details of pilot function.....	82
	Table 28 — Compliance test for protective conductor continuity checking.....	83
	Table 29 — Compliance test for rated Outputs and maximum Output power.....	85
	Table 30 — Compliance test for protection against overvoltage at the battery.....	89

Table 31 — Compliance test for emergency shutdown in case of control pilot disconnection.....	91
Table 32 — Compliance test for load dump.....	93
Table 33 — Compliance test for protection against uncontrolled reverse power flow from vehicle.....	94
Table 34 — Compliance test for limiting the inrush current by d.c. Electric Vehicle Supply equipment to 2A.....	95
Table 35 — Compliance test for Output current regulation in CCC (including static deviation and ripple) and measurement accuracy.....	96
Table 36 — Compliance test for Output voltage regulation in CVC during pre-charging and measurement accuracy.....	100
Table 37 — Compliance test for control delay of charging current in CCC.....	103
Table 38 — Compliance test for descending rate of charging current.....	107
Table 39 — Compliance test for insulation check to detect low insulation resistance before pre-charge.....	109
Table 40 — Compliance test for insulation check to detect fault state during charging.....	110
Table 41 — Compliance test 2 for self-test after fault state.....	111
Table 42 — Compliance test for short-circuit between CP and PE.....	113
Table 43 — Compliance test for short-circuit and overcurrent protection.....	114
Table 44 — Compliance test for measured voltage values during welding detection.....	117
Table 45 — Compliance test for user initiated shutdown.....	118
Table 46 — Compliance test for short circuit test before charging.....	119
Table 47 — The possible combinations for multi-outlet d.c. Electric Vehicle Supply equipments.....	
Table 48 — Example of system schematic for each use case (1 of 4).....	
FIG. 1 Control pilot test system.....	6
FIG. 2 Earth-fault test system.....	9
FIG. 3 Short-Circuit test system for testing control circuit integrity.....	10
FIG. 4 Typical voltages between d.c.+/- and protective conductor in conditions without earth fault.....	11
FIG. 5 IMD connection which results in exceedance of maximum voltage limits.....	11
FIG. 6 Maximum voltage between D.c.+/- and protective conductor in conditions with a single earth fault.....	12
FIG. 7 Examples of temporary voltage waveform and the maximum voltage limit at the d.c. Output.....	13
FIG. 8 Insulation barriers.....	19
FIG. 9 Measuring network of touch current weighted for perception or reaction.....	23
FIG. 10 Voltage tolerances.....	32
FIG. 11 Step response for constant value control.....	34
FIG. 12 Maximum ratings for voltage dynamics.....	35
FIG. 13 Reference device C_0.....	37
FIG. 14 Test arrangement C_0.....	38
FIG. 15 Reference device C_1.....	38
FIG. 16 Test arrangement C_1.....	39
FIG. 17 Example of artificial load.....	41
FIG. 18 Operating Points.....	44
FIG. 19 Interface components for configuration FF.....	46
FIG. 20 Example charging sequence.....	48
FIG. 21 Sequence diagram for normal start up.....	51
FIG. 22 Sequence diagram and description for normal shutdown by EV/EVSE.....	55
FIG. 23 Sequence diagram for d.c. EV Supply equipment and EV initiated error shut down.....	59
FIG. 24 Sequence diagram for d.c. EV Supply equipment and EV initiated emergency shutdown.....	62
FIG. 25 Circuit diagram with components influencing the touch current.....	67
FIG. 26 Equivalent circuits for example in Fig. 25.....	67
FIG. 27 Worst case equivalent circuit for the EV during the pre-charge process.....	70
FIG. 28 Voltage measurement points for the pre-charge process.....	71
FIG. 29 System schematic example of system C.....	75
FIG. 30 Operating points.....	79
FIG. 31 Standard test setup circuit diagram.....	79
FIG. 32 Test point grid.....	85
FIG. 33 Test point grid for Output current regulation in CCC including static deviation and ripple.....	95
FIG. 34 Test point grid for Output voltage regulation in CVC during precharging.....	100
FIG. 35 Test point grid for control delay of charging current in CCC.....	103
FIG. 36 Test point grid for descending rate of charging current.....	108
FIG. 37 Example of block diagram of bi-directional power flow system.....	113
FIG. 38 EV charging and discharging modes.....	115

FIG. 39 Example of typical isolated system.....120
FIG. 40 Example of typical non-isolated system.....120
FIG. 41 Example of simplified isolated system.....121
FIG. 42 Example of d.c. Supply network system.....121
FIG. 43 Typical configuration of d.c. charging system.....122
FIG. 44 Dual socket architecture.....124
FIG. 45 Charging phases for dual gun charging.....125
FIG. 46 Communication protocol between EVSE and CMS.....127

Indian Standard

ELECTRIC VEHICLE CONDUCTIVE CHARGING SYSTEM

PART 30 DUAL GUN d.c. ELECTRIC VEHICLE SUPPLY EQUIPMENT

1 SCOPE

This standard covers the dual gun d.c. electric vehicle supply equipment for charging electric road vehicles, with a rated supply voltage up to 1 000 V a.c. or up to 1 500 V d.c. and a rated output voltage up to 1 500 V d.c.

This standard specifies the dual gun d.c. electric vehicle supply equipment of System C as defined in [Annex A](#). Requirements for systems that do not comply with System C are not covered by this standard.

Requirements for non-isolated system are under consideration and are not specified in this standard.

The requirements for digital communication between dual gun d.c. electric vehicle supply equipment and electric vehicle for control of d.c. charging are defined in IS 17017 (Part 24) : 2021.

Non-regulated dual gun d.c. electric vehicle supply equipment is not covered by this standard.

NOTES

1 This document includes information on electric vehicle for conductive connection but limited to the necessary content for describing the power and signalling interface.

2 Typical diagrams and variation of dual gun d.c. charging systems are shown in [Annex B](#).

2 REFERENCES

This clause of IS 17017 (Part 23) is applicable.

3 TERMINOLOGY

This clause of IS 17017 (Part 1) is applicable except as follows:

Addition:

3.1 Electric Supply Equipment**3.1.101 d.c. EV Charging System for Dual Gun**

A system composed of a d.c. charger with two separate cable assemblies for two EVCCs and the equipment(s) on electric vehicle that is required to fulfil the charging function including digital communication for charging control.

3.1.102 Isolated d.c. EV Supply Equipment

d.c. electric vehicle supply equipment where the d.c. output circuit is separated by at least basic insulation from other circuits.

NOTE — See 8 for the requirements of separation between each circuit.

3.1.103 Non-Isolated d.c. EV Supply Equipment

d.c. electric vehicle supply equipment where the d.c. output circuit is not separated by protective separation from the a.c. supply network.

3.1.104 Regulated Dual Gun d.c. EV Supply Equipment

d.c. electric vehicle supply equipment that supplies vehicle battery with charging current or charging voltage through two individual charging guns in accordance with the request from vehicle.

3.1.105 Non-Regulated Dual Gun d.c. EV Supply Equipment

Under consideration.

3.1.106 Plug and Cable d.c. EV Supply Equipment

d.c. electric vehicle supply equipment which is intended to be connected to the a.c. supply network using a cable and plug according to IS/IEC 60309-1 and IS/IEC 60309-2 for industrial type, IS 1293 for domestic type, other relevant national standards, or other standard plugs and socket outlets.

3.1.107 Charging State

A physical status of d.c. electric vehicle charging system

3.1.108 Controlled Current Charging (CCC)

Energy transfer method where the d.c. electric vehicle supply equipment regulates charging current according to the current value requested by the vehicle.

3.1.109 Controlled Voltage Charging (CVC)

Energy transfer method where the d.c. electric vehicle supply equipment regulates charging voltage according to the voltage value requested by the vehicle.

3.1.110 Constant Current Control Mode (CCCM)

A control mode of electric vehicle supply equipment that regulates the output current as constant during the control process according to the target-current value requested by the vehicle or the other sources such as thermal management unit of electric vehicle supply equipment.

3.1.111 Constant Voltage Control Mode (CVCM)

A control mode of electric vehicle supply equipment that regulates the output voltage as constant during the control process according to the target-voltage value requested by the vehicle.

3.1.112 Constant Power Control Mode (CPCM)

A control mode of electric vehicle supply equipment that regulates the output power as constant during the control process according to the target-power value requested by the vehicle or the other sources such as the demand management of the grid.

3.1.113 Electric Vehicle Supply Equipment (EVSE)

Conductors, including the phase(s), neutral and protective earth conductors, the electric vehicle couplers, attached plugs, and all other accessories, devices, power outlets or apparatuses installed specifically for the purpose of delivering energy from the premises wiring to the electric vehicle and allowing communication between them as necessary.

3.1.114 Supply Equipment Communication Controller (SECC)

Entity which implements the communication to one or multiple Electric Vehicle Communication Controllers (EVCCs) according to IS/ISO 15118-2 and which may be able to interact with secondary actors.

3.2 Insulation

3.2.101 Isolation

Function intended to make dead for reasons of safety all or a discrete section of the electrical installation by separating the electrical installation or section from every source of electric energy.

3.2.102 (Electrically) Protective Separation

Separation of one Electric circuit from another by means of:

- a) Double insulation; or
- b) Basic insulation and protective screening (shielding); or
- c) Reinforced insulation

3.3 Functions

3.3.101 Control Circuit

Circuit for signal and digital communication with vehicle and for the management of charging control process.

3.3.102 d.c. Charging Control Function (DCCCF)

A function embedded in a d.c. electric vehicle supply equipment which controls d.c. power output following VCCF direction.

3.3.103 Vehicle Charging Control Function (VCCF)

A function in a vehicle which controls the charging parameters of off-board d.c. electric vehicle supply equipment.

3.3.104 Normal Shutdown

Termination of the charging process initiated by the user, by the vehicle or by the d.c. electric vehicle supply equipment, and not caused by a failure.

3.3.105 Error Shutdown

Termination of the charging process caused by a failure detected by the d.c. electric vehicle Supply equipment or the vehicle.

3.3.106 Emergency Shutdown

Urgent termination of the charging process caused by a failure detected by the d.c. electric vehicle supply equipment or the vehicle that may present a safety hazard.

NOTE — Emergency shutdown may be done by disconnecting the d.c. electric vehicle supply equipment from supply network.

3.3.107 Thermal Sensing

Method for obtaining temperature data of accessories, cable assemblies or parts thereof.

3.3.108 Thermal Transport

Method for managing the heat dissipation of accessories, cable assemblies or parts thereof, independent of changing the current.

3.3.109 Thermal Sensing Device

Means for providing temperature data of accessories, cable assemblies or parts thereof.

3.3.110 Thermal Transport Device

Means for managing heat dissipation of accessories, cable assemblies or parts thereof, independent of changing the current.

3.3.111 Thermal Exchange

Method for cooling and dissipating thermal energy from the thermal transport.

3.3.112 Thermal Exchange Device

Means for cooling and dissipating thermal energy from the thermal transport.

3.3.113 Thermal Management System

System having thermal sensing, thermal exchange and thermal transport in order to keep the temperature in the allowed limit.

3.3.114 High Level Communication (HLC)

Bi-directional digital communication using protocol, messages and physical and data link layers specified in IS 17017 (Part 24).

3.4 Vehicle**3.4.101 Maximum Voltage Limit**

Upper limit value of charging voltage sent by the vehicle to the d.c. electric vehicle supply equipment.

3.4.102 Maximum Charging Current of the Vehicle

Maximum limit of the charging current of the vehicle which may change over time.

3.5 Cords, Cables and Connection Means**3.5.101 Y-Capacitance**

Total capacitance bridging the isolation barriers of the d.c. output to other circuits and earth.

NOTES

1 The capacitors are of a type suitable for use in situations where failure of the capacitor could lead to danger of electric shock.

2 The total capacitance is commonly distributed equally between the two d.c. rails.

3.6 Service and Usage**3.6.101 Ordinary Person**

Person who is neither a skilled person nor an instructed person

NOTE — Ordinary persons include users of the d.c. electric vehicle supply equipment. Persons who may have access to the d.c. electric vehicle supply equipment and who may be in the vicinity of the d.c. electric vehicle supply equipment. Under normal operating conditions, ordinary persons should not be exposed to energy sources causing startle reaction, pain or injury.

3.6.102 Skilled Person

Person with relevant education and experience to enable him or her to perceive risks and to avoid hazards which electricity can create.

3.6.103 Instructed Person

Person adequately advised or supervised by electrically skilled persons to enable him or her to perceive risks and to avoid hazards which electricity can create.

3.6.104 Restricted Access

Limited access to the d.c. electric vehicle supply equipment, for example, by private housing, private camping areas or similar places.

3.6.105 Non-Restricted Access

Unlimited access to the d.c. electric vehicle supply equipment for all persons, for example, public areas.

3.7 General Terms**3.7.101 Primary Circuit**

a circuit that is directly connected to the a.c. or d.c. supply network and includes the primary windings of transformers, other loading devices and the means of connection to the supply network.

3.7.102 Secondary Circuit

a circuit that has no direct connection to a primary circuit and derives its power from a transformer, converter or equivalent isolation device.

3.7.103 Rated Current

Input or output current under normal operating conditions assigned by the manufacturer.

3.7.104 Contact Assembly

Power contact with a terminal and additional component, if any.

NOTE — For example, termination, contact support, thermal sensing, thermal transport etc.

3.7.105 Sleep Mode

Deactivation or performance reduction of internal subsystem in order to minimize power consumption.

3.7.106 d.c. Output Voltage

Voltage between d.c. power line terminals, that is, between positive terminal d.c. + and negative terminal d.c. – for individual charging gun.

3.7.107 Touch Current

Electric current passing through a human body or through livestock when it touches one or more accessible parts of an installation or of equipment.

3.7.108 Touch Voltage

Voltage between conductive parts when touched

simultaneously by a human or livestock.

NOTE — The value of the effective touch voltage may be appreciably influenced by the impedance of the person or the livestock in electric contact with these conductive parts.

3.7.109 *Fire Enclosure*

Part of the equipment intended to minimize the spread of fire or flames from within.

3.7.110 *Enhanced Protection*

Protective provision having a reliability of protection not less than that provided by two independent protective provisions.

3.7.111 *PELV (System)*

Electric system in which the voltage cannot exceed the value of extra low voltage under normal conditions and under single fault conditions, except earth faults in other electric circuits.

NOTE — PELV is protective extra low voltage.

3.7.112 *SELV (System)*

Electric system in which the voltage cannot exceed the value of extra-low voltage under normal conditions and under single fault conditions, including earth faults in other electric circuits.

NOTE — SELV is safety extra low voltage.

3.7.113 *Power Electronic Converter System (PECS)*

One or more power electronic converters intended to work together with other equipment.

3.7.114 *Protective Impedance*

Impedance connected between hazardous live parts and accessible conductive parts, of such value that the current, in normal use and under likely fault conditions, is limited to a safe value and which is so constructed that its ability is maintained throughout the life of the equipment.

3.7.115 *Protective-Equipotential-Bonding*

Equipotential bonding for purposes of safety (for example, protection against electric shock)

3.7.116 *(Electrically) Protective Screening*

Separation of circuits from hazardous live-parts by means of an interposed conductive screen connected to the means of connection for a PE conductor, either directly or via protective equipotential bonding.

3.7.117 *Single Fault Condition*

Condition in which one failure is present which could cause a hazard.

NOTES

1 If a single fault condition results in other subsequent failures, the set of failures is considered as one single fault condition.

2 Examples of hazards include, but are not limited to electric shock, fire, energy, mechanical, sonic pressure etc.

3.7.118 *Startle Reaction*

Physiological reaction due to a minimum derived value of touch voltage for a population for which a current flowing through the body is just enough to cause involuntary muscular contraction to the person through which it is flowing.

3.7.119 *Working Voltage*

Voltage, at rated supply conditions (without tolerances) and worst case operating conditions, that occurs by design in a circuit or across insulation.

NOTE — The working voltage can be d.c. or a.c. Both the r.m.s. and recurring peak values are used.

3.7.120 *Insulation Monitoring Device (IMD)*

Device which permanently monitors the insulation resistance to earth of unearthed a.c. IT systems, a.c. IT systems with galvanically connected d.c. circuits having nominal voltages up to 1 000 V a.c., as well as monitoring the insulation resistance of unearthed d.c. IT systems with voltages up to 1 500 V d.c., independent from the method of measuring.

3.7.121 *Earth Leakage Current Monitoring Device*

Passive electrical device for monitoring insulation resistance of unearthed d.c. system by measuring leakage current between live parts and exposed conductive part or earth.

4 GENERAL REQUIREMENTS

This clause of IS 17017 (Part 1) is applicable, except as follows:

Replacement: 4.6 not applicable.

5 CLASSIFICATION

Not applicable.

6 CHARGING MODES AND FUNCTIONS

This clause of IS 17017(Part 1) is applicable, except

as follows:

6.3 Functions Provided in Mode 4

6.3.1 Mandatory Functions in Mode 4

6.3.1.1 General

The d.c. electric vehicle supply equipment shall supply a d.c. current or voltage to the vehicle battery in accordance with a VCCF request.

The following functions shall be provided by d.c. electric vehicle supply equipment as given below:

- a) Continuous continuity checking of the protective conductor according to [6.3.1.2](#);
- b) Verification that the electric vehicle is properly connected to the electric vehicle supply equipment according to [6.3.1.3](#) of IS 17017 (Part 1);
- c) Energization of the power supply to the electric vehicle according to [6.3.1.4](#);
- d) De-energization of the power supply to the electric vehicle according to [6.3.1.5](#);
- e) Maximum allowable current (per charging gun) per cable assembly according to [6.3.1.6](#) of IS 17017 (Part 1);
- f) d.c. supply for electric vehicle according to [6.3.1.101](#);
- g) Measuring current and voltage according to [6.3.1.102](#);
- h) Latching of the vehicle coupler according to [6.3.1.103](#);
- j) Compatibility assessment according to [6.3.1.104](#);
- k) Insulation check before charging according to [6.3.1.105](#);
NOTE — In the case of charging the Electric Vehicle with two cable assemblies, the insulation check has to be carried out only on one d.c. bus, as it is an operational requirement.
- m) Protection against over voltage at the interface according to [6.3.1.106](#);
- n) Verification of vehicle connector latching according to [6.3.1.107](#) 
- p) Control circuit Supply integrity according to [6.3.1.108](#);
- q) Short circuit test before charging according to [6.3.1.109](#);
- r) User initiated shutdown according to [6.3.1.110](#);
- s) Overload protection for parallel conductors (conditional function) according to [6.3.1.111](#);
- t) Voltage limitation between d.c. output and

protective conductor according to [6.3.1.112](#) and [6.3.1.113](#); and

- u) Shutdown of d.c. electric vehicle supply equipment according to [6.3.1.114](#), [6.3.1.115](#), [6.3.1.116](#), and [6.3.1.117](#).

Replacement:

6.3.1.2 Continuous continuity checking of the protective conductor

The protective conductor continuity between the d.c. electric vehicle supply equipment and the vehicle shall be monitored continuously. For the rated voltage of d.c. 60 V or higher, the d.c. electric vehicle supply equipment shall trigger and completely execute an emergency shutdown after a loss of electrical continuity of the protective conductor between d.c. electric vehicle supply equipment and electric vehicle.

Compliance for System C is checked by [A-9.3.4](#).

This test case applies to d.c. electric vehicle supply equipments with the maximum output voltage ≥ 60 V. The test system is shown in [Fig. 44](#).

The test shall be performed according to the following procedure:

- a) Connect the d.c. electric vehicle supply equipment to an artificial load with dedicated electric vehicle simulator for each system;
- b) Measure the voltage ($V_{EVSE\ Output}$) and current ($I_{EVSE\ Output}$) of the power line continuously;
- c) Start charging with the procedure specified by charger manufacturer;
- d) Confirm that the power flow of d.c. power line is at OP4 specified in [Fig. 18](#);
- e) Open the relay K;
- f) Check that the d.c. electric vehicle Supply equipment terminates the charging process and transfers to shutdown stage, displaying a relevant alarm or error information, if any; and
- g) Confirm that the d.c. power line between d.c. electric vehicle supply equipment and electric vehicle is de-energized to voltage less than 60 V.

NOTE — Protective conductor continuity is monitored by the control pilot, see [A-4.3](#) for System C.

6.3.1.4 Energization of the power supply to the EV Addition:

Compliance is checked by the following test. The test system is shown in [Fig. 1](#).

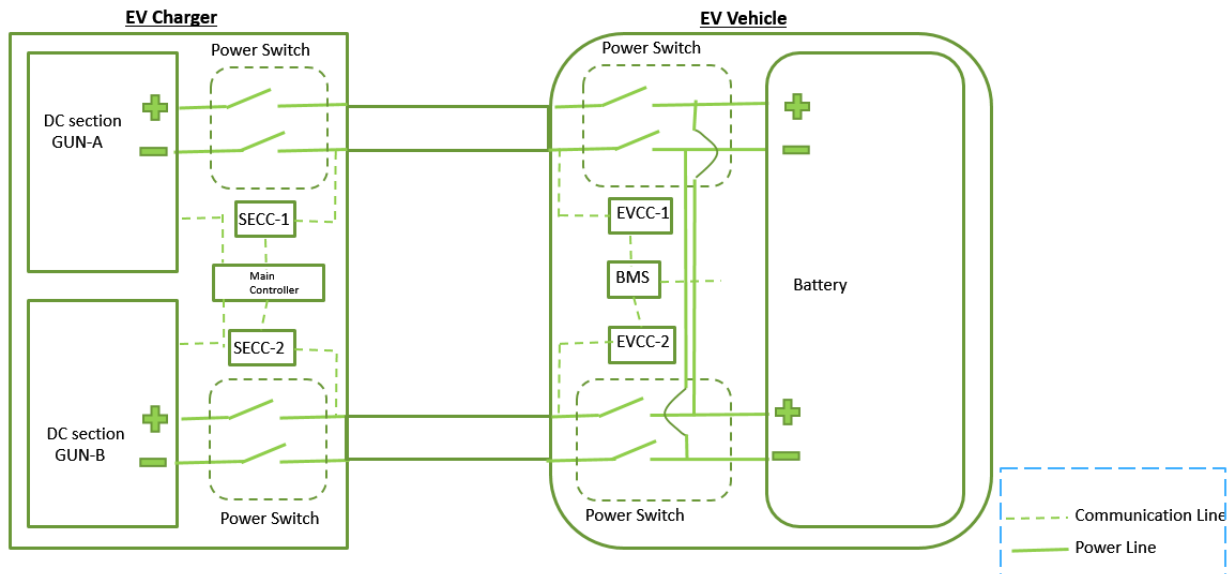

Key

- SECC 1 supply equipment communication controller for charging Gun A
- SECC 2 supply equipment communication controller for charging Gun B
- EVCC 1 electric vehicle communication controller for charging Gun A
- EVCC 2 electric vehicle communication controller for charging Gun B

FIG. 1 CONTROL PILOT TEST SYSTEM

The test shall be performed according to the following procedure:

- a) Connect the d.c. electric vehicle supply equipment to an artificial load with dedicated electric vehicle simulator for each system.
- b) Measure the voltage (V_{EVSE}) of the power line continuously.
- c) Simulate the open circuit of control pilot by opening the relay. The control pilot lines to be tested for each system are shown below:
 - 1) System C: CP [see A-2 of IS 17017 (Part 1) : 2018]
- d) Start charging with the procedure specified by the manufacturer; and
- e) Confirm that the power line at Point B has not been energized.

6.3.1.5 De-energization of the power supply to the EV

Addition:

Compliance is checked for System C by the test in [A-9.3.3](#).

In the case of failure in control circuit of d.c. electric vehicle supply equipment, such as short-circuit, earth leakage, CPU failure or excess temperature, the d.c. electric vehicle supply

equipment shall terminate the supply of charging current, and disconnect the supply of control circuit.

In the case where earth fault or overcurrent is detected, the conductor shall be disconnected from its supply.

Compliance is checked according to ISO 26262 or IEC 61508.

Addition:

6.3.1.101 d.c. Supply for EV

The d.c. electric vehicle supply equipment shall supply regulated d.c. voltage or current (not simultaneously, but as requested by the vehicle during charging) to the vehicle battery in accordance with VCCF's controlling. Requirements for charging performance of regulated d.c. current/voltage are given in [101.2.1](#), [101.2.2](#), [101.2.3](#), [101.2.4](#), [101.2.5](#) and [101.2.6](#).

In either case mentioned above, the maximum ratings of the d.c. electric vehicle supply equipment shall not be exceeded.

Compliance is checked by measurement.

The vehicle can change the requested current and/or requested voltage.

NOTE — Electric vehicles are equipped with different technologies and different voltages of battery. In order to avoid any error during charging and to guarantee that the d.c. electric vehicle supply equipment will be able to charge

all existing and future batteries, any charging process is controlled by the vehicle. Any vehicle that is to be connected to a d.c. electric vehicle Supply equipment is equipped with a VCCF for controlling the charging process.

6.3.1.102 Measuring current and voltage

The d.c. electric vehicle supply equipment shall measure the output current and output voltage that is supplied to the electric vehicle. The accuracy of these measurements shall meet the defined accuracy in [A-6.5](#).

The measured values of voltage and current shall be provided by the d.c. electric vehicle supply equipment to the electric vehicle through digital communication.

Compliance for System C is checked by [A-9.3.12](#) and [A-9.3.13](#).

6.3.1.103 Latching of the vehicle coupler

A vehicle connector used for d.c. charging shall be latched on a vehicle inlet if the d.c. output voltage is higher than 60 V between d.c. + and d.c. –, or higher than 28 V between d.c.+ and earthing terminal, and d.c. – and earthing terminal.

The vehicle connector shall not be unlatched (if the latching mechanism is engaged) when voltage exceeding 60 V d.c. is detected through the charging process including after the end of charging. In case of charging system malfunction, a means for safe disconnection may be provided.

NOTES

1 The actuation portion of the latching function can be in either the vehicle connector or the vehicle inlet.

2 Voltage criteria for latching/unlatching function can be lower than 60 V d.c.

The d.c. electric vehicle supply equipment shall have the following functions when the latching is done by the d.c. electric vehicle supply equipment:

- a) Electrical or mechanical latching function to retain the latched status;
- b) Function to detect the disconnection of the electrical circuits for the latching function;

Compliance is checked by the following tests c) and d).

- c) Normal condition test — Simulate a normal charging operation. Check that the vehicle connector is latched on the vehicle inlet whenever the voltage at the inlet is higher than or equal to 60 V d.c. between d.c. + and d.c. –, or higher than or equal to 28 V between d.c. + and earthing terminal, and d.c. – and earthing terminal; and
- d) Abnormal condition test simulate a condition in which the voltage at the vehicle inlet remains higher than or equal

to 60 V d.c. between d.c. + and d.c. –, or higher than or equal to 28 V between d.c. + and earthing terminal, and d.c. – and earthing terminal after the end of charging, for example, by forcibly keeping the electric vehicle contactors closed. Check that the vehicle connector is latched on the vehicle inlet whenever the voltage at the inlet is higher than or equal to 60 V d.c. between d.c. + and d.c. –, or higher than or equal to 28 V between d.c. + and earthing terminal, and d.c. – and earthing terminal.

Additional requirements are given in [A-4.2](#).

Vehicle connectors and vehicle inlets shall comply with the requirements of IS 17017 (Part 2/Sec 1) and IS 17017 (Part 2/Sec 3). See [9.101](#).

6.3.1.104 Compatibility assessment

Compatibility of electric vehicle and d.c. electric vehicle supply equipment shall be checked with the information exchanged at the initialization phase of communication and charging process.

For System C, the d.c. electric vehicle supply equipment checks that its minimum voltage is less than the maximum voltage of the electric vehicle battery. In case this condition is not met, the d.c. electric vehicle supply equipment terminates the charging process.

NOTE — General information of charging control and commutation are described in [Annex D](#).

The compliance is checked by the following test:

- a) Connect the d.c. electric vehicle supply equipment to an artificial load with a dedicated electric vehicle simulator for each system;
- b) Start charging with the procedure specified by charger manufacturer;
- c) Using the electric vehicle simulator, transmit the data or message in [Table 1](#) to the d.c. electric vehicle supply equipment via digital communication;
- d) For each case, check that the d.c. electric vehicle supply equipment terminates the charging process and transfers to shutdown stage, displaying a relevant alarm or error information, if any;
- e) For System C, see [A-9.3.1](#); and
- f) Confirm that the d.c. power line between the d.c. electric vehicle supply equipment and the electric vehicle is de-energized to voltage less than 60 V between d.c. + and d.c. –, or less than 28 V between d.c. + and earthing terminal, and d.c. – and earthing terminal.

Table 1 Data/Message for Transmission Test(Clause [6.3.1.104](#))

SI No.	System	Data/Message [refer to IS 17017 (Part 24)]
(1)	(2)	(3)
i)	C	see A-9.3.1

6.3.1.105 Insulation Check before Charging

The d.c. electric vehicle supply equipment shall confirm the insulation resistance between its d.c. output circuit and protective conductor to the vehicle chassis, including any exposed conductive part of the d.c. electric vehicle supply equipment, before the electric vehicle contactors are allowed to close.

If the required value is not met, the d.c. electric vehicle supply equipment shall trigger and perform an error shutdown and indicate to the vehicle that the charging is not allowed.

For System C, see [A-4.1.3](#).

6.3.1.106 Protection against overvoltage between positive terminal d.c.+ and negative terminal d.c.– at the interface

The d.c. electric vehicle supply equipment shall trigger an error shutdown within the maximum time given in [Table 3](#) to prevent overvoltage at the interface after occurrence of the fault.

NOTE — The vehicle can change the maximum voltage limit during charging process. The vehicle should consider some margin between the target battery voltage and maximum voltage limit communicated to the d.c. electric vehicle supply equipment to avoid unwanted stop of the charging process.

Compliance for System C is checked by [A-9.3.6](#).

6.3.1.108 Control circuit supply integrity

If an earth fault, short circuit or overcurrent is detected in the output circuit of d.c. electric vehicle supply equipment, the power circuit shall be disconnected from its Supply, but the power supply for control circuit shall not be interrupted until the charging sequence is completed and the vehicle coupler is safely unlatched.

The compliance is checked by the following tests according to [Table 3](#).

Table 2 Error Shutdown Trigger Timing(Clause [6.3.1.106](#))

SI No.	System	Fault	Maximum Time After Occurrence of the Fault to Trigger Error Shutdown
(1)	(2)	(3)	(4)
i)	C	Output voltage exceeds the maximum voltage limit sent by the vehicle for 400 consecutive milliseconds	10 ms

Table 3 Control Circuit Supply Integrity Test(Clauses [6.3.1.106](#) and [6.3.1.108](#))

SI No.	Fault Scenario	System C
(1)	(2)	(3)
i)	Earth fault	A-9.3.16.2
ii)	Short circuit	A-9.3.18
iii)	Overcurrent	A-9.3.18

a) Earth-fault test

The test system is shown in Fig. 2. The test shall be performed according to the following procedure:

- 1) An artificial load (see 102.2.3) with a dedicated electric vehicle simulator for each system is connected to d.c. electric vehicle supply equipment correctly under normal operation;
- 2) d.c. output voltage is at the rated value;
- 3) The d.c. electric vehicle supply equipment is operated in the constant voltage control mode (System C);
- 4) Simulate the earth-fault by changing the position of the relay or switch L from open to 1;
- 5) Check that the earth-fault is detected properly and the d.c. electric vehicle

supply equipment transfers to a fault state;

- 6) Confirm that the voltage of the power supply for control circuit at point A remains the same or within a specified range that ensures the normal operation of the control circuit;
- 7) Check that the d.c. electric vehicle supply equipment terminates the charging process and transfers to the error shutdown stage according to 6.3.1.116; and
- 8) Repeat the procedures 1 to 7 for the case in which the position of the relay or switch L is changed from open to 2 in 4.

b) Short-circuit test

The test system is shown in Fig. 3.

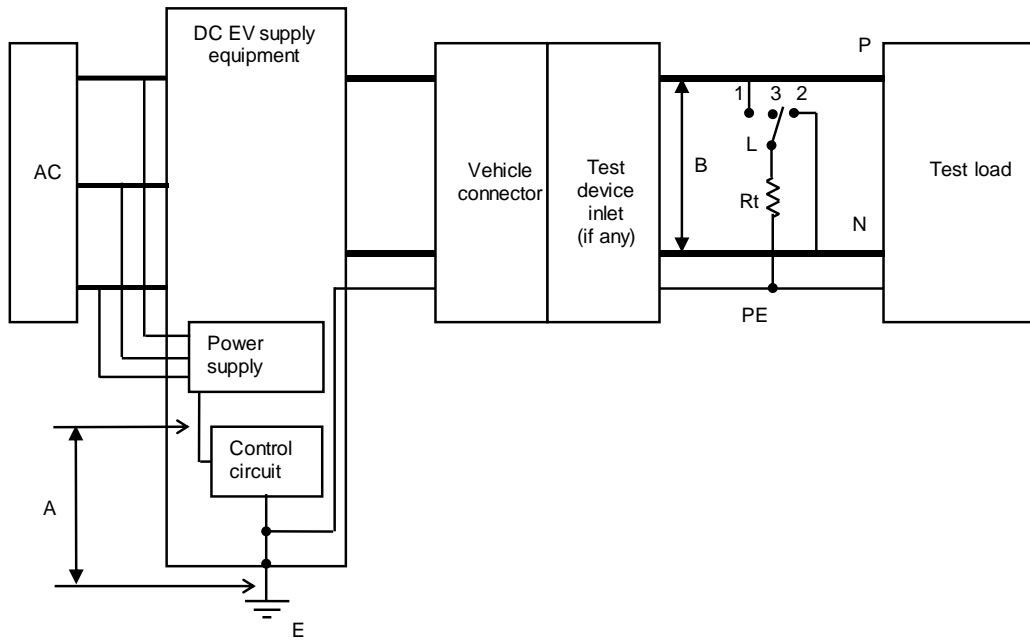

Key

- | | | | |
|---|---|----|------------------------|
| A | voltage of the power supply for control circuit | N | d.c.- |
| B | d.c. output voltage | P | d.c.+ |
| E | earth | PE | protective conductor |
| L | selector switch | Rt | earth-fault resistance |
| 1 | terminal 1 to replicate earth-fault between P and E | | |
| 2 | terminal 2 to replicate earth-fault between N and E | | |
| 3 | open position of selector switch L | | |

FIG. 2 EARTH-FAULT TEST SYSTEM

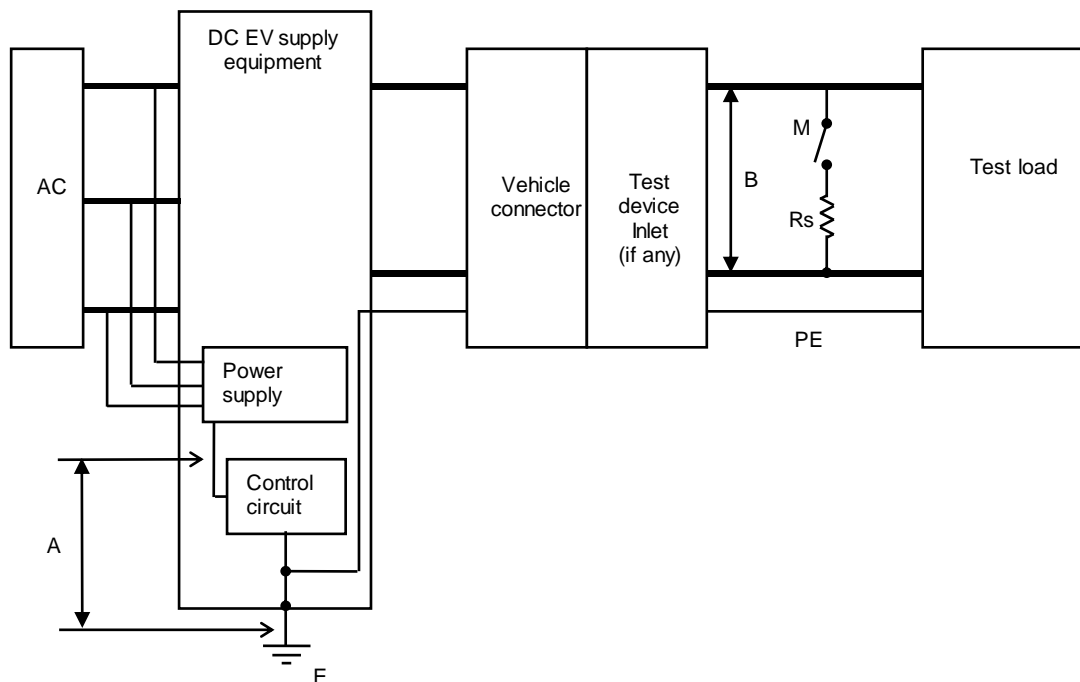

Key

- A voltage of the power supply for control circuit
- B voltage of the power line
- M switch or relay to replicate short-circuit
- Rs short circuit resistor (100 mΩ)

FIG. 3 SHORT-CIRCUIT TEST SYSTEM FOR TESTING CONTROL CIRCUIT INTEGRITY

The test shall be performed according to the following procedure:

- 1) An artificial load with dedicated electric vehicle simulator for each system is connected to the d.c. electric vehicle supply equipment correctly under normal operation. If an electronic load is used, it shall not interfere with the measurement;
- 2) The power line (B) is energized at the rated voltage;
- 3) The d.c. electric vehicle supply equipment is operated in the constant voltage control mode (System C).
- 4) Simulate the short circuit by closing the relay or switch M;
- 5) Check that the short circuit is detected properly and the d.c. electric vehicle supply equipment transfers to a fault state; and
- 6) Confirm that the voltage of the power supply for control circuit at Point A remains the same or within a specified range that ensures the normal operation of

the control circuit.

6.3.1.109 Short-Circuit check before charging

With the electric vehicle connected to the d.c. electric vehicle supply equipment and before the electric vehicle contactor is closed, the d.c. electric vehicle supply equipment shall have a means to check for a short circuit between d.c. output circuit positive and negative up to the electric vehicle contactor.

If short circuit is detected, the d.c. electric vehicle supply equipment shall trigger and perform an error shutdown.

For system C, see [A-9.3.21](#)

6.3.1.110 User initiated shutdown

The d.c. electric vehicle supply equipment shall have a means to allow the user to initiate the normal shutdown.

Compliance is checked by the tests in [A-9.3.20](#).

6.3.1.111 *Overload protection for parallel conductors (conditional function)*

If more than one conductor or wire and/or vehicle connector contact is used in parallel for d.c. current supply to the vehicle, the d.c. electric vehicle supply equipment shall have a means to ensure that none of the conductors or wires will be overloaded.

Compliance is checked by design review.

NOTE — For example, the currents on the different path can be monitored or more than one power source can be used.

6.3.1.112 *Maximum voltage between d.c. +/- and protective conductor in conditions without earth fault*

Under normal operation, no voltage higher than the d.c. output voltage plus 50 V shall occur between d.c. power line terminals (d.c. + as positive terminal, and d.c.– as negative terminal) and protective conductor at the output of the d.c. electric vehicle supply equipment. This voltage

limitation does not apply for transient overvoltages (see Fig. 4 and Fig. 5).

Components of d.c. electric vehicle supply equipment, for example, an IMD, may superimpose a common mode voltage to protective conductor onto the d.c. output. At low output voltage, this may shift the d.c. rails up to d.c. output voltage + 50 V compared to protective conductor.

Component of d.c. electric vehicle supply equipment may shift each d.c. output rail up to protective conductor through a resistor, which results in a large common mode output voltage swing.

The measurement circuits might introduce a larger common mode voltage offset if connected to an intermediate bus voltage. These circuits shall not cause a voltage shift that exceeds the requirements in 6.3.1.112.

Fig. 5 shows an example of an incorrect implementation

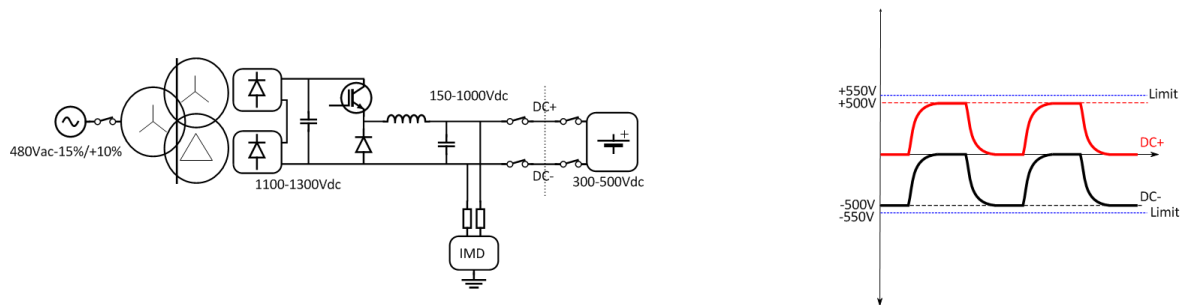

FIG. 4 TYPICAL VOLTAGES BETWEEN D.C. +/- AND PROTECTIVE CONDUCTOR IN CONDITIONS WITHOUT EARTH FAULT

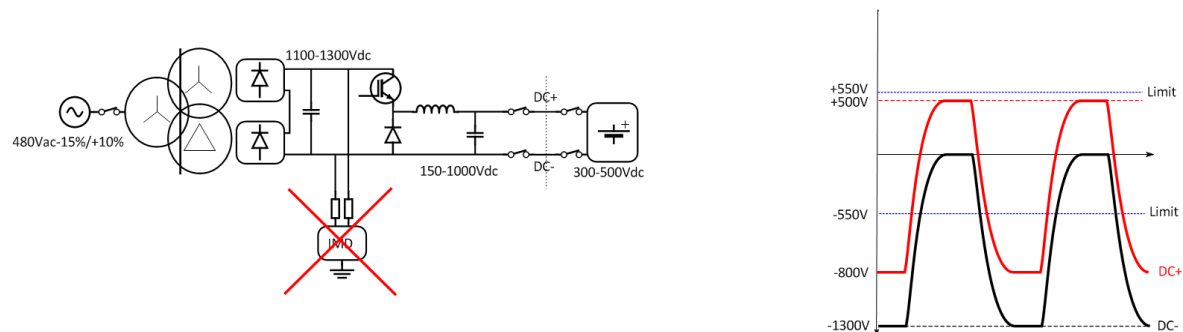

FIG. 5 IMD CONNECTION WHICH RESULTS IN EXCEEDANCE OF MAXIMUM VOLTAGE LIMITS

6.3.1.113 Maximum voltage between d.c.+/- and protective conductor in conditions with a single earth fault

For d.c. electric vehicle supply equipments serving a maximum rated output voltage up to 500 V, no voltage higher than 550 V shall occur for more than 5 s at the output between d.c. + and protective conductor or between d.c. - and protective conductor (see Fig. 6).

If a voltage higher than 550 V is present for more than 1 s between d.c. + and protective conductor or between d.c. - and protective conductor, the d.c. electric vehicle supply equipment shall have completed an error shutdown within 5 s after occurrence of the overvoltage.

For d.c. electric vehicle supply equipments serving a maximum output voltage above 500 V and up to 1 000 V, no voltage higher than 110 percent of d.c. output voltage shall occur for more than 5 s at the output between d.c.+ and protective conductor or between d.c. - and protective conductor.

If a voltage higher than 110 percent of the d.c. output voltage is present for more than 1 s between d.c. + and protective conductor or between d.c. - and protective conductor, the d.c. electric vehicle supply equipment shall have completed an error shutdown within 5 s after occurrence of the overvoltage.

For voltage above 1 000 V, under consideration.

Within the first 5 s of an earth fault condition, the d.c. electric vehicle supply equipment shall limit the temporary overvoltage V_{tov} as defined in ISO 6469-3 and IS 15382 (Part 1) between d.c.+/- and protective conductor to:

$$(2 U_{min} + 1 000) \times 1.41 \text{ V or;}$$

$$(U_{min} + 1 200) \times 1.41 \text{ V, whichever is less.}$$

where

U_{min} is the minimum rated d.c. output voltage

Figure 7 shows an example of temporary voltage waveform and the maximum voltage limit at the d.c. output.

6.3.1.114 Shutdown of d.c. EV Supply Equipment

At the end of a shutdown sequence, the d.c. electric vehicle supply equipment shall reduce d.c. output current to equal to or less than 5 A, and shall be designed such that d.c. output voltage remains equal to or less than 60 V between d.c. + and d.c. - and equal to or less than 28 V between d.c. + and earthing terminal and d.c. - and earthing terminal.

6.3.1.115 Normal Shutdown

Normal shutdown occurs as a result of an intrinsic reaction of the vehicle or the d.c. electric vehicle supply equipment or a user interaction, for reasons other than the presence of a failure.

At the end of the normal shutdown sequence, the d.c. electric vehicle supply equipment shall reduce its output as follows:

- a) d.c. output current ≤ 5 A; and
- b) d.c. output voltage remains ≤ 60 V between d.c. + and d.c. - and remains ≤ 28 V between d.c. + and earthing terminal, and d.c. - and earthing terminal.

Adequate provision shall be made to ensure that there is a time difference of “t” seconds, as specified by OEM, between shutdown of both the charging guns.

Further requirements are specified in A-3.3.

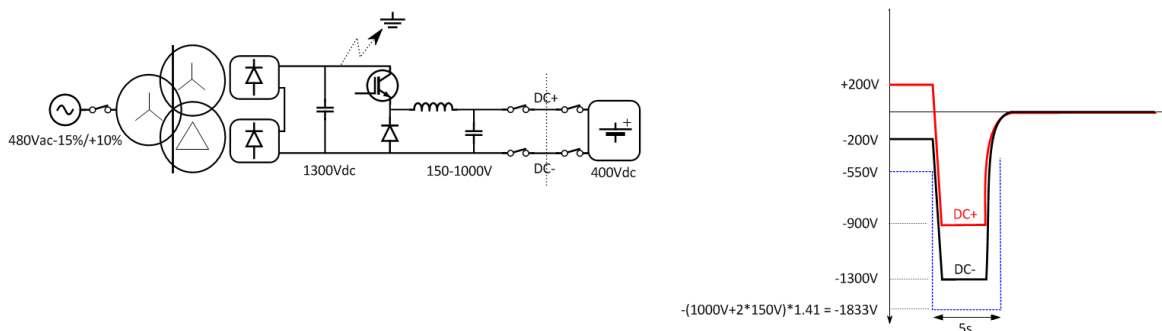
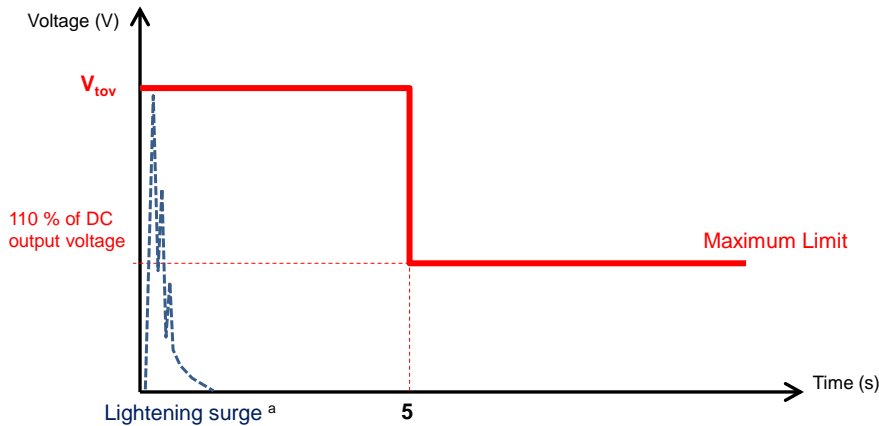

FIG. 6 MAXIMUM VOLTAGE BETWEEN D.C. +/- AND PROTECTIVE CONDUCTOR IN CONDITIONS WITH A SINGLE EARTH FAULT



EXAMPLE
Example:

^a Lightning surge appears at the common-mode d.c. output as a result of its input to the a.c. input circuit of d.c. Electric Vehicle supply equipment.

FIG. 7 EXAMPLES OF TEMPORARY VOLTAGE WAVEFORM AND THE MAXIMUM VOLTAGE LIMIT AT THE D.C. OUTPUT

6.3.1.116 Error Shutdown

After the error shutdown is triggered by the d.c. electric vehicle supply equipment, the d.c. electric vehicle supply equipment shall reduce its output as follows:

- a) d.c. output current ≤ 5 A;
- b) d.c. output voltage remains ≤ 60 V between d.c.+ and d.c.– and remains ≤ 28 V between d.c.+ and earthing terminal, and d.c.– and earthing terminal, within times as specified in Annex A; and
- c) Timing and further requirements to initiate an error shutdown are specified for System C in [A-3.4](#).

NOTE — The compliance test verifies the shutdown time which consists of performance time plus trigger time as defined in the clauses referring to error shutdown. The trigger time does not need to be verified provided shutdown time complies with the specific requirement.

6.3.1.117 Emergency shutdown

After the emergency shutdown is triggered by the d.c. electric vehicle supply equipment, the d.c. electric vehicle supply equipment shall reduce its output as follows:

- a) d.c. output current ≤ 5 A within 30 ms; and
- b) d.c. output voltage ≤ 60 V between d.c. + and d.c. –, and ≤ 28 V between d.c. + and earthing terminal, and d.c. – and earthing terminal within 1 s for System C.

NOTES

1 The compliance checks the total time which consists of the timings above plus triggering time as defined in

the clauses referring to emergency shutdown. The trigger time does not need to be verified provided shutdown time complies with the specific requirement.
2 A welded contactor on the vehicle can prevent the d.c. electric vehicle supply equipment to reduce the voltage.

Further requirements are specified in [A-3.4](#).



Compliance for System C is checked by [A-9.3.7](#) and [A-9.3.8](#).

Replacement of title [6.3.2](#):

6.3.2 Optional Functions for Mode 4

6.3.2.1 General

The following functions, if provided by the d.c. electric vehicle supply equipment, shall comply with applicable clauses as given below:

- a) ventilation during supply of energy according to [6.3.2.2](#); 
- b) mode 4 using the combined charging system according to [6.3.2](#); 
- c) wake up of d.c. electric vehicle supply equipment by electric vehicle according to [6.3.2.101](#); and
- d) detection/adjustment of the real time available load current of the d.c. Electric Vehicle supply equipment according to [6.3.2.102](#).

Other additional functions may be provided.

NOTES

1 Un-intentional live disconnect avoidance functions may be incorporated in the latching function interlock system.

2 A positive means to prevent unintentional disconnect is required.

3 Primary protection against overvoltage and overcurrent of vehicle battery is the responsibility of the vehicle.

Addition:

6.3.2.101 *Wake up of d.c. EV supply equipment by EV*

The d.c. electric vehicle supply equipment may support a sleep mode to minimize power consumption.

In this case, d.c. electric vehicle supply equipment shall be able to be woken up by the electric vehicle.

The d.c. electric vehicle supply equipment shall:

- 1) For system C, see [A-5.2](#).

6.3.2.102 *Detection/adjustment of the real time available load current of the d.c. EV supply equipment*

The d.c. electric vehicle supply equipment may change the available current and shall transmit it to vehicle via digital communication. The vehicle should limit the current request value in accordance with the change in the available current. The current request value shall be less than or equal to the available current.

7 COMMUNICATIONS

This clause of IS 17017 (Part 1) is applicable except as follows:

7.1 Digital Communication between the EV Supply Equipment and EV

Addition:

Protective measures defined in this standard shall not rely on communicated values between the d.c. electric vehicle supply equipment and electric vehicle.

[Annex D](#) provides general information on the communication and charging process between electric vehicle and d.c. electric vehicle supply equipment.

Addition:

7.1.101 *Basic Communication Interface*

Typical interfaces of control pilot function on d.c. electric vehicle charging systems are specified in Annex A. Each system carries out control pilot function through the control pilot conductors and terminals specified in IS 17017 (Part 2/Sec 3).

8 PROTECTION AGAINST ELECTRIC SHOCK

This clause of IS 17017 (Part 1) is applicable, except as follows:

Addition:

8.101 General Provisions

8.101.1 *General*

Requirements for protection against electric shock shall be according to 4.4 of IEC 62477-1 : 2016, which provides safety requirements for power electronic converter systems (PECS) and equipment.

For the purposes of this standard, the d.c. electric vehicle supply equipment is considered to be a type of PECS equipment.

Hazard based safety models according to IS/IEC 62368-1 : 2014 may be used to evaluate protection against electric shock.

Protection against the risk of electric shock and the hazard including the output circuit of d.c. electric vehicle supply equipment under conditions of intended use and reasonably foreseeable misuse shall be provided at least by one of the following measures.

- a) Basic protection and fault protection, see [8.102](#) and [8.103](#); and
- b) Enhanced protection, see [8.104](#).

Protection under normal operating conditions is provided by basic protection, and protection under single fault conditions is provided by fault protection.

Specific protective measures for the secondary circuit supplying the d.c. output are provided in [8.105](#).

Protection of the a.c. primary circuits of d.c. electric vehicle supply equipment may include an RCD according to [8.105.7](#).

Specific requirements for protective measures for d.c. electric vehicle supply equipment having non-isolated d.c. output circuits are under consideration.

8.101.2 *Intended Use and Reasonably Foreseeable Misuse*

Considering intended use and reasonably foreseeable misuse:

- a) hazardous-live-parts shall not be accessible and accessible-conductive-parts shall not be hazardous live; and

- b) hazardous currents shall not be disconnected with the vehicle connector.

Compliance for hazardous-live-parts is checked according to [8.102](#), [8.103](#) and [8.104](#).

Compliance for hazardous currents is checked according to [6.3.1.103](#).

8.101.3 *Limitation of Touch Current or Touch Voltage*

Under normal operating conditions and single fault conditions, an ordinary person shall be protected against a harmful electric shock by either:

- a) limiting the touch currents, or
- b) limiting the touch voltage.

Body impedance corresponding to water wet conditions in **3.1.8** of IS/IEC 60479-1 shall be considered under the normal operation conditions and single fault conditions.

Compliance for hazardous-live-parts is checked according to [8.102](#), [8.103](#), [8.104](#) and [8.105](#).

NOTE — The skin of a sweating person or a person after immersion in seawater is not considered.

8.101.4 *Threshold of Perception and Startle Reaction*

Protective measures shall be provided to prevent startle reactions during intended use, before, during and after an energy transfer session, under normal conditions and during single fault conditions. During the normal operating conditions, perception may be possible.

For the current path, finger-to-feet at the interface and hand-to-feet at the chassis shall be considered.

Protection by means of limitation of touch current shall be provided, such that a steady-state touch current flowing between simultaneously accessible conductive parts shall not exceed:

- a) 0.5 mA a.c./2 mA d.c. under normal operation; and
- b) 3.5 mA a.c./10 mA d.c. under single fault condition.

Additional protection shall be provided, such that in case of a double fault, touch current does not exceed the d.c. 2 limit (line B) in Fig. 22 and Table 13 of IEC 60479-1 : 2018.

Compliance is checked by measurement according to [12.6](#).

Protection by means of limitation of discharge energy shall be provided, such that discharge energy shall not exceed:

- a) 5 μ J under normal operation; and

- b) 0.5 mJ under single fault condition.

Additional protection shall be provided such that in case of a double fault, the discharge energy does not exceed the C1 limit in Fig. 23 of IEC 60479-2 : 2017.

Compliance is checked by design review.

8.102 Basic Protection

8.102.1 *General*

Basic protection in d.c. electric vehicle supply equipment is employed to prevent persons from touching hazardous live parts. It shall be provided by one or more of the measures given in [8.102.2](#), [8.102.3](#), [8.102.4](#), and [8.102.5](#).

8.102.2 *Protection by Means of Basic Insulation of Live Parts*

Protection by means of basic insulation of live parts in d.c. electric vehicle supply equipment shall be according to **4.4.3.2** of IEC 62477-1 : 2016.

Basic insulation shall be provided by solid insulation or clearance and/or creepage distance.

Any accessible conductive part is considered to be a hazardous live part if not separated from the live parts by required insulation.

Basic insulation shall be designed and tested to withstand the impulse voltages and temporary overvoltages for the circuits to which they are connected.

Compliance is checked by inspection and test.

Test shall be conducted according to **5.2.3.2** and **5.2.3.4** of IEC 62477-1 : 2016.

8.102.3 *Protection by Means of Enclosures or Barriers*

Protection by means of enclosures or barriers in d.c. electric vehicle supply equipment shall be according to **4.4.3.3** of IEC 62477-1 : 2016.

Enclosures shall be suitable for use in their intended environments.

The d.c. electric vehicle supply equipment shall have adequate mechanical strength and shall be so constructed that no hazard occurs when subjected to intended use and expected misuse over the expected lifetime.

It shall only be possible to open enclosures or remove barriers:

- a) with the use of a tool or key; or
- b) after de-energization of hazardous live parts.

For constructional requirements, see [12.109](#).

8.102.4 Protection by Means of Limitation of Voltage

Basic protection by the provision of limitation of voltage is fulfilled where the following conditions are met:

- a) steady-state touch voltage under normal operation does not exceeds the values in [Table 4](#);
- b) steady- state touch voltage under single fault condition does not exceed the values in [Table 5](#);

c) the voltage is supplied by one of the following sources:

- 1) a safety isolating transformer for the auxiliary circuit including control pilot;
- NOTE — Safety isolating transformers are those that comply with IEC 61558-2-6.
- 2) a source of voltage providing a degree of safety equivalent to that of a safety isolating transformer; and
- 3) electro chemical (for example, battery).

Table 4 Touch Voltage under Normal Operation (Water Wet)

(Clause [8.102.4](#))

SI No.	Body Contact Area	a.c. (rms)	d.c.
(1)	(2)	(3)	(4)
i)	Part of body	Basic protection required	
ii)	Hand		
iii)	Finger tip	8.0 V	22.0 V
NOTE — Values are derived from Table 5 of IEC 62477-1 : 2016. The values are based on a current path from the contact area of the body to feet, with the person in standing position.			

Table 5 Touch Voltage under Single Fault Conditions (Water Wet)

(Clause [8.102.4](#))

SI No.	Body Contact Area	a.c. (rms)	d.c.
(1)	(2)	(3)	(4)
i)	Part of body	Basic protection required	
ii)	Hand		
iii)	Finger tip	12.0 V	28.0 V
iv)	Hand-to-feet	-	22.0 V
<p>NOTES</p> <p>1 Values are derived from Table 5 of IEC 62477-1 : 2016. The values are based on a current path from the contact area of the body to feet, with the person in standing position.</p> <p>2 If these values cannot be met under single fault conditions, protective separation is needed.</p>			

Compliance is checked by inspection and measurement.

8.102.5 Protection by Means of Limitation of Steady-State Touch Current

Limitation of steady-state touch current is a provision whereby touch current is limited to non-hazardous values. The limits are provided in [8.101.4](#).

The protective impedance limiting the touch current shall comply with [4.4.5.4](#) of IEC 62477-1 : 2016.

The protective impedance shall be so designed and tested to withstand the impulse voltages and temporary overvoltages as tested according to [5.2.3.2](#) and [5.2.3.4](#) of IEC 62477-1 : 2016.

Compliance is checked by measurement according to [12.6](#).

8.103 Fault Protection

8.103.1 General

Fault protection provides protection against bodily harm due to contact with hazardous electrical energy during and after failure of the basic protection.

Fault protection shall be provided by one or more of the following measures:

- a) protective equipotential bonding in [8.103.2](#) in combination with the protective conductor;
- b) automatic disconnection of Supply in [8.103.4](#);
- c) supplementary insulation in [8.103.5](#); and
- d) Electrically protective screening in [8.103.6](#).

Fault protection shall be independent and additional to those for basic protection.

In case the d.c. Electric Vehicle supply equipment or the d.c. charging/discharging station can supply more than one vehicle simultaneously, independent protection means (overcurrent and fault current) for each vehicle connector shall be provided in accordance with one or more of the provisions in [8.103.2](#), [8.103.3](#), [8.103.4](#), [8.103.5](#) and [8.103.6](#).

8.103.2 Protective-Equipotential-Bonding

Protective-equipotential-bonding is a provision whereby items are bonded together to avoid hazardous touch voltages.

Protective-equipotential-bonding in d.c. electric vehicle supply equipment shall be according to [4.4.4.2](#) of IEC 62477-1 : 2016.

Compliance is checked by inspection.

8.103.3 Effective Earth Continuity between the Enclosure and the External Protective Circuit

Exposed conductive parts of the d.c. electric vehicle supply equipment shall be effectively connected to

the terminal for the external protective earthing conductor, and the resistance from the conductive part to the terminal of the external protective earthing conductor shall not exceed 0.1 Ω .

Compliance is checked by the following test.

- a) Make verification using a resistance measuring instrument which is capable of driving a current of at least 10 A (a.c. or d.c.). Pass the current between each exposed conductive part and the terminal for the external protective conductor; and
- b) Confirm that the resistance does not exceed 0.1 Ω .

NOTES

1 It is recommended to limit the duration of the test where low-current equipment otherwise may be adversely affected by the test.

2 Routine testing can be performed according to [5.2.3.11.4](#) of IEC 62477-1 : 2016.

8.103.4 Automatic Disconnection of Supply

Automatic disconnection of supply in d.c. electric vehicle supply equipment shall be according to [4.4.4.4](#) of IEC 62477-1 : 2016 except as follows:

The protective device may be provided in any suitable upstream part of the installation or d.c. electric vehicle supply equipment. The manufacturer of d.c. electric vehicle supply equipment shall give appropriate information for the installation of external protection. The information may be provided in a detailed electric diagram.

Compliance is checked by inspection and measurement.

8.103.5 Supplementary Insulation

Supplementary insulation in d.c. electric vehicle supply equipment shall be according to [4.4.4.5](#) of IEC 62477-1 : 2016.

Compliance is checked by inspection.

8.103.6 Electrically Protective Screening

Electrically protective screening in d.c. electric vehicle supply equipment shall be according to [4.4.4.7](#) of IEC 62477-1 : 2016. Electrically protective screening shall consist of a conductive screen interposed between hazardous-live-parts of the d.c. electric vehicle supply equipment and the part being protected, whereby the screen is separated from live parts by at least basic insulation.

The protective screen shall:

- a) be connected to the protective-equipotential-bonding system of the d.c. electric vehicle supply equipment and that

interconnection shall comply with the requirements of **4.4.4.2** of IEC 62477-1 : 2016; and

- b) comply with the requirements for elements of the protective-equipotential-bonding system according to **5.3.3.3**, **5.3.3.4** and **5.3.3.5** of IEC 61140 : 2016.

Compliance is checked by inspection.

8.104 Enhanced Protection

8.104.1 General

An enhanced protective provision shall provide both basic protection under normal conditions and protection under single fault conditions in accordance with one or more of the provisions specified in [8.104.2](#) and [8.104.3](#).

8.104.2 Reinforced Insulation

Reinforced insulation in d.c. electric vehicle supply equipment shall be according to **4.4.5.2** of IEC 62477-1 : 2016.

Compliance is checked by inspection.

8.104.3 Protective Separation between Circuits

Protective separation between circuits in d.c. electric vehicle supply equipment shall be according to **4.4.5.3** of IEC 62477-1 : 2016.

Compliance is checked by inspection.

8.105 Requirements of the Isolated d.c. EV Supply Equipment

8.105.1 General

Between the d.c. circuit and the ordinary person, double insulation, reinforced insulation, or basic insulation and electrically protective screening (shielding), shall be used as basic and fault protection.

For System C, insulation monitoring or leakage current monitoring in the d.c. electric vehicle supply equipment shall detect the first fault and disconnect the supply or shutdown the transfer of energy. This is not protection against electric shock but can prevent a hazardous electric shock on a second fault.

For detailed description, refer to [A-4.1](#).

The reaction time of the insulation monitoring device or earth leakage current monitoring device shall be according to [A-4.1.4](#). The value of the Y capacitances shall ensure that the reaction time of the insulation monitoring device or earth leakage current monitoring device is not exceeded. In any case, Y capacitance shall be less than 500 nF per rail for d.c. electric vehicle supply equipment.

The limitation of stored energy in the Y-capacitors shall not be used as fault protection for the d.c. electric vehicle supply equipment.

Additional protection may be provided by limited impedance between the d.c. output and the protective conductor, including the connected electric vehicle (*see* [8.101.4](#) for the requirements for additional protection).

Requirements for the isolated d.c. electric vehicle supply equipment for protection against electric shock hazard are defined for each system in [A-4.1](#).

Outside of a fire enclosure, d.c.+ and d.c.– shall be separated by double or reinforced insulation for both the charging guns independently from each other and other circuits.

In case of dual gun charging through d.c. electric vehicle supply equipment, independent protection for both the charging guns (overcurrent and fault current) for each vehicle connector shall be used in order to ensure selectivity.

In addition, if the d.c. electric vehicle supply equipment has multiple d.c. outputs designed for simultaneous operation, each output circuit shall be isolated from each other by basic insulation, double or reinforced insulation.

8.105.2 Degrees of Protection against access to Hazardous-Live-Parts

IP ratings for enclosures of d.c. electric vehicle supply equipment shall fulfil at least IPXXC. Compliance is checked by inspection and measurement.

8.105.3 Insulation Barriers

The d.c. electric vehicle supply equipment shall have insulation barriers as shown in [Fig. 8](#). The d.c. electric vehicle supply equipment shall provide the minimum protective measures as defined in [Table 6](#).

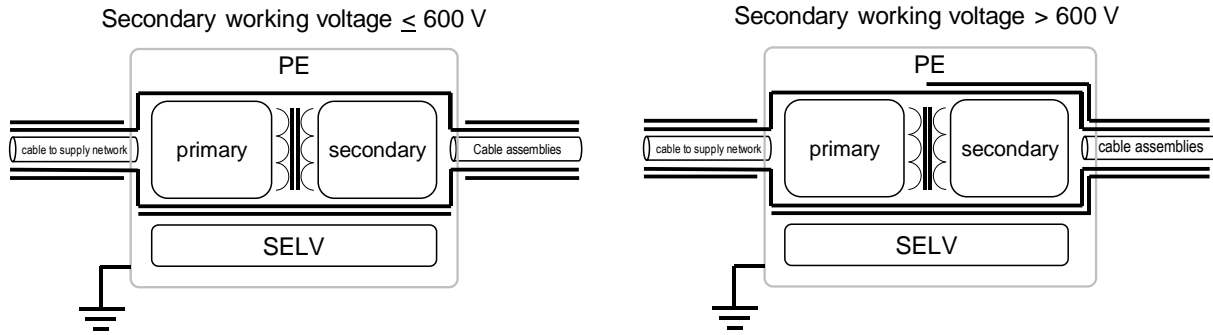

Key

PE protective conductor

FIG. 8 INSULATION BARRIERS

Table 6 Minimum Protective Measures

(Clause 8.105.3)

SI No. (1)	(2)	d.c. (3)	SELV (4)	Protective Conductor (5)	Ordinary Person (6)
i)	a.c.	Protective separation	Protective separation	Single insulation ^a	Protective separation
ii)	d.c.	-	Protective separation ^b	Single insulation (< 600 V) Double insulation (> 600 V) ^c	Protective separation
iii)	SELV	-	-	Functional insulation ^d	None
iv)	Protective conductor	-	-	-	None

^a Local regulations may require double insulation. In some countries, extra monitoring of protective conductor is required when using single insulation. For some system, for example, TT systems, double insulation to protective conductor is required up to the RCD, if one is installed in the d.c. electric vehicle supply equipment.

^b If the SELV circuit is connected to protective conductor and will not be damaged by the fault current, no hazardous voltages shall occur in the SELV circuit, and the IMD or earth leakage current monitoring device will detect the failure and trigger an error shutdown within 10 s (*under consideration*), single insulation between d.c. and SELV is allowed for some components, for example, contactors.

^c If on the secondary (d.c.) side, there is a circuit with a working voltage greater than 600 V, double insulation to the protective conductor is required. Additional protective measures are taken to limit the impedance to the protective conductor.

^d SELV may be connected to the protective conductor. If SELV is floating a 500 V r.m.s. test voltage may be applied to test the insulation

8.105.4 Stored Energy

8.105.4.1 Disconnection of plug and cable connected d.c. EV Supply Equipment

For plug and cable connected d.c. electric vehicle supply equipment, where the connection pins are accessible after unplugging, one second after disconnecting the standard plug from the standard socket-outlet, for instance as described in IEC TR 60083 : 2015 or IEC 60309-1, the voltage between any combination of accessible contacts of the standard plug shall be less than or equal to 28 V d.c. and 12 V a.c. (r.m.s.) or the stored energy available shall be less than 0.5 mJ.

Compliance is checked by inspection and by test with the electric vehicle disconnected according to 2.1.1.5 of IEC 60950-1 : 2005.

8.105.4.2 Loss of Supply voltage to permanently connected d.c. EV supply equipment

The voltage between power lines or power lines and protective earthing conductor, when measured at the input supply terminals of the d.c. electric vehicle supply equipment, shall be less than or equal to 28 V d.c. and 12 V a.c. (r.m.s.) or the stored energy shall be less than or equal to 0.5 mJ within 5 s after disconnecting the power Supply voltage to the d.c. electric vehicle supply equipment.

Compliance is checked by inspection and by test with no electric vehicle connected to the d.c. electric vehicle supply equipment according to 2.1.1.7 of IEC 60950-1 : 2005.

8.105.5 Disconnection from Vehicle

If the voltage between any contacts at the vehicle connector exceeds 28 V d.c. or 12 V a.c. (r.m.s.) during charging, the electric vehicle supply equipment shall comply with at least one of the following requirements:

- a) The energy between any contacts shall be below 0.5 mJ within 1 s after disconnection of the vehicle connector from the vehicle inlet (Case 1); and
- b) The voltage between any contacts shall be below or equal to 28 V d.c. and 12 V a.c. (r.m.s.) within 1 s after disconnection of the vehicle connector from the vehicle inlet (Case 2).

The voltage or energy shall be measured at the unmated vehicle connector.

The test shall be performed according to the following procedure:

- a) The d.c. electric vehicle supply equipment is connected to an artificial load as defined in [102.2.3](#);

b) The power line is energized at the maximum output voltage of the d.c. electric vehicle supply equipment; and

c) Start the measurement of voltage between each contact (P-N, P-GND and N-GND):

- 1) Stop charging based on the stop sequence defined by each system; and
- 2) The test is passed:

- i) for Case 1, if the stored energy at 1 s after disconnecting all the signal lines or the connector-latch circuit, if any, is less than the defined value. The energy is calculated by using the corresponding values of capacitances determined before and the documented voltage 1 s after triggering. *see* formula (2); and

$$E = 0.5 \times C \times V^2 \quad \dots(2)$$

where

E = energy 1 s after triggering in Joule;

C = capacity in farad; and

V = voltage 1 s after triggering in volt.

- ii) for Case 2, if the voltage values between any contacts fall to less than 28 V in 1 s or less after disconnecting all the signal lines or the connector latch circuit, if any.

8.105.6 Protective Earthing Conductor from Supply Network

The protective earthing conductor and the protective conductor from the supply network shall be of sufficient rating in accordance with requirements of 543.1.2 of IEC 60364-5-54 : 2011.

The d.c. electric vehicle supply equipment shall provide either:

- a) protective earthing conductor from the input earthing terminal of the a.c. supply network to the d.c. electric vehicle supply equipment; or
- b) protective conductor from the d.c. electric vehicle supply equipment to the electric vehicle if fault protection is based on protective separation. *See* requirements in [8.105.9](#).

For permanently connected d.c. electric vehicle supply equipment, protective earthing conductors shall not be switched.

Protection Class II d.c. electric vehicle supply equipment shall have a lead-through protective

conductor with double insulation or reinforced insulation for earthing the electric vehicle chassis.

Compliance is checked by inspection.

8.105.7 Residual Current Protective Devices

The d.c. electric vehicle supply equipment intended for fixed installation may rely on RCD(s) incorporated in the d.c. electric vehicle supply equipment and/or provided upstream by the installation as defined in the installation manual of the d.c. electric vehicle supply equipment and relevant wiring diagrams.

Plug and cable d.c. electric vehicle supply equipment shall be provided with RCD(s) within the d.c. electric vehicle supply equipment or on the cable or plug, and double insulation to the protective conductor is required between the plug and any parts not protected by RCD(s).

RCDs incorporated in d.c. electric vehicle supply equipment shall be at least of Type A and comply with one of the following standards: IS 12640 (Part 1), IS 12640 (Part 2), or IS/IEC 60947-2.

RCDs incorporated on the cable, if any, shall be at least of Type A and comply with IEC 61540.

RCDs shall disconnect all live conductors.

Manufacturer shall check compliance with RCDs incorporated in the d.c. electric vehicle supply equipments, or to be provided by the installation, by simulation or calculation of current in the protective conductor under normal and single fault conditions according to the guideline provided in Annex H of IEC 62477-1 : 2016.

Plug and cable d.c. electric vehicle supply equipments shall always be designed such that under normal and fault conditions any resulting d.c. component of the current in the protective conductor never exceed 6 mA.

Compliance is checked by inspecting the construction and documents provided by the manufacturer.

NOTE — Limitation of d.c. component of the current in the protective conductor can be achieved by double or reinforced insulation of the circuit that can cause a d.c. leakage current to any other circuit and protective conductor, or d.c. leakage detection that disconnects the circuit that causes excessive d.c. leakage current.

8.105.8 Safety Requirements for Signalling Circuits between the d.c. EV Supply Equipment and the EV

Any circuit for signalling, which extends beyond the d.c. electric vehicle supply equipment enclosure for connection with the electric vehicle, for example, control pilot circuit shall be extra low voltage (SELV or PELV) according to IEC 62477-1.

Compliance is checked by inspection.

8.105.9 Protective Conductor Dimension Cross-Sectional Area

The protective earthing conductor or protective conductor of the secondary circuit of d.c. electric vehicle supply equipment shall be designed according to [A-4.7](#).

Compliance is checked by inspection and measurement.

9 CONDUCTIVE ELECTRICAL INTERFACE REQUIREMENTS

This clause of IS 17017 (Part 1) is applicable, except as follows:

9.1 General

Replacement:

The physical conductive electrical interface requirements between the vehicle and the d.c. electric vehicle supply equipment are as defined in IS 17017 (Part 2/Sec 3).

9.2 Functional description of Standard Accessories

Not applicable.

9.7 Wiring of the Neutral Conductor

Not applicable except the following:

Wiring instructions shall be provided in the manual (see [16.1](#)).

Addition:

9.101 Avoidance of Breaking under Load

For d.c. charging, the vehicle couplers are rated 'not for current interruption.' A disconnection shall not take place under load.

In addition to latching mechanism defined in [6.3.1.103](#), in case of unintended disconnection of the vehicle coupler, the output current of the d.c. electric vehicle supply equipment shall be turned off within a defined time to contain a possible arc within the vehicle coupler housing. This turn-off time shall comply with the value specified in [A-4.3](#) using a speed of separation of the vehicle connector of $0.8 \text{ m/s} \pm 0.1 \text{ m/s}$ according to IS 17017 (Part 2/Sec 1).

Disconnection of vehicle coupler shall be detected by interruption of interlock circuit(s), for example, control pilot, proximity circuit, to mitigate electrical arcing and shock hazards.

Compliance is checked by the test in [6.3.1.117](#).

The system specific requirement for breaking capacity and system redundancy are defined in [A-4.3](#) for System C.

10 REQUIREMENTS FOR ADAPTORS

This clause of IS 17017 (Part 1) is applicable.

11 CABLE ASSEMBLY REQUIREMENTS

This clause of IS 17017 (Part 1) is applicable, except as follows:

Addition:

11.101 Cable Breakaway

The cable shall be connected to the enclosure in such a way that, if the cable anchorage fails, the conductors break in the following sequence:

- a) first, the control pilot conductor/ conductors;
- b) second, the current carrying conductors; and
- c) third, the protective earthing conductor, if any.

12 EV SUPPLY EQUIPMENT CONSTRUCTIONAL REQUIREMENTS AND TESTS

This clause of IS 17017 (Part 1) is applicable except as follows:

12.1 General

Addition:

The d.c. electric vehicle supply equipment shall comply with the restrictions/limitations as specified in the data sheet of the cable assembly manufacturer.

Compliance is checked by inspection.

12.2 Clearances and Creepage Distances

Replacement of the first paragraph:

The clearance and creepage distances in the electric vehicle supply equipment, installed as intended by the manufacturer, shall be in accordance with the requirements specified in IEC 62477-1.

Addition:

The d.c. output circuit of each individual charging gun of d.c. electric vehicle supply equipment shall be designed according to a rated impulse voltage of at least 2 500 V.

Compliance is checked according to **12.7** of IS 17017 (Part 1) : 2018.

12.4 IP Degrees

12.4.1 Degrees of Protection against Solid Foreign Objects and Water for the Enclosures

Addition:

For the d.c. electric vehicle supply equipment of stationary type, the test conditions can be defined in accordance with installation conditions.

12.5 Insulation Resistance

Addition:

Insulation resistance does not include components bridging insulation according to **12.109** and IMD or earth leakage current monitoring device.

When the d.c. output is energized, the actual total physical insulation resistance of the d.c. electric vehicle supply equipment between d.c. +/- to protective earthing conductor, that will not result in a shutdown, shall limit the touch current within the d.c. 2 area of Fig. 22 of IEC 60479-1 : 2018.

NOTES

- 1 The test is made without an insulation monitoring system.
- 2 The actual total physical insulation resistance is a combination of the impedance of the all components within the d.c. electric vehicle supply equipment and the electric vehicle.
- 3 The measured insulation resistance does not include the impedance of the insulation resistance measurement device.

12.6 Touch Current

This clause of IS 17017 (Part 1) does not apply except Table 1.

Addition:

12.6.101 Touch-Current Limit

The touch current between any a.c supply network poles and the accessible metal parts connected with each other and with a metal foil covering insulated external parts shall not exceed the values indicated in Table 1 of IS 17017 (Part 1).

The test shall be made when the d.c. electric vehicle supply equipment is functioning with an artificial load according to Fig. 17 at rated output power.

For permanently connected Class I d.c. electric vehicle supply equipment, if the test touch current exceeds 3.5 mA, **12.6.103** is applicable.

Circuitry which is connected through a fixed

resistance or referenced to protective earthing conductor, for example, electric vehicle connection check, should be disconnected before this test.

Compliance is checked by the test in [12.6.102](#).

12.6.102 Test

12.6.102.1 Test configuration

Test configurations for measurement of leakage current shall be according to **5.4.1** of IEC 60990 : 2016.

12.6.102.2 Application of measuring network

The measuring network is defined in [Fig. 9](#). Terminal A of the measuring network is connected to each conductive or unearthed accessible surface in turn. For each application of the Terminal A electrode, the Terminal B electrode is applied to earth, then to each of the other accessible parts in turn. All accessible conductive or unearthed surfaces are to be tested for touch currents.

For an accessible non-conductive part, the test is made to metal foil having dimensions of 100 mm by 200 mm in contact with the part.

12.6.102.3 Test condition

The touch current shall be measured after the damp heat test, with the d.c. electric vehicle supply equipment connected to a.c. supply network in accordance with **6** of IS/IEC 60990 : 2016. The supply voltage shall be 1.1 times the nominal rated voltage.

Measurements shall be made with each of the applicable fault conditions in accordance with **6.2.2** of IEC 60990 : 2016.

12.6.102.4 Test measurements

The r.m.s. value of the voltage, U_2 , shall be measured using the measuring instrument in [Fig. 9](#). Formula (3) shall be used to calculate the touch current:

$$\text{Touch Current(A)} = U_2/500 \quad \dots(3)$$

None of the values measured in accordance with [12.6.102.2](#) shall exceed the relevant limits specified in [12.6.101](#).

12.6.103 Protection Measures for the Touch Current Exceeding 3.5 mA

For the a.c. supply circuit of a Class I d.c. electric vehicle supply equipment, if the test touch current exceeds 3.5 mA r.m.s, one of the following requirements shall be met. The touch current shall be measured under the fault condition with earthing conductor closed:

- a) The protective earthing conductor shall have a cross-sectional area of at least 10 mm² Cu or 16 mm² Al, through its total run;
- b) Where the protective earthing conductor has a cross-sectional area of less than 10 mm² Cu or 16 mm² Al, a second protective earthing conductor of at least the same cross-sectional area shall be provided up to a point where the protective earthing conductor has a cross-sectional area not less than 10 mm² Cu or 16 mm² Al; and

NOTE — (b) can require that the d.c. electric vehicle supply equipment has a separate terminal for a second protective earthing conductor.

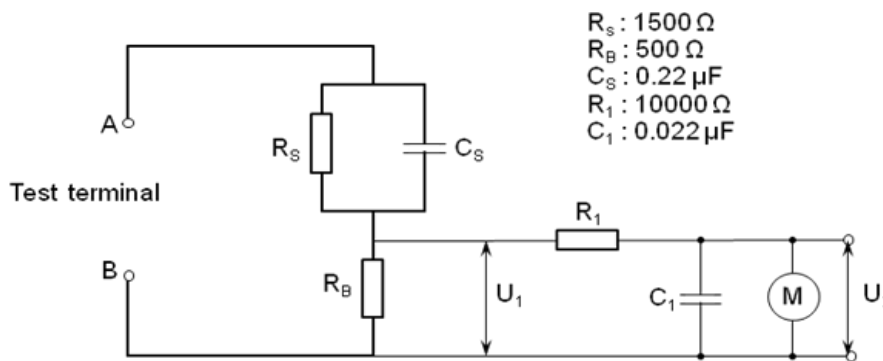

Key

A B	Terminal of the measuring Network	U_1, U_2	Output voltage
C_1, C_S	Capacitor	R_1, R_B, R_S	Resistor
		M	Measuring instrument

FIG. 9 MEASURING NETWORK OF TOUCH CURRENT WEIGHTED FOR PERCEPTION OR REACTION

For accuracy of touch current measuring instruments, see **G-3** of IS/IEC 60990 : 2016.

- c) Automatic disconnection of the supply in case of loss of continuity of the protective earthing conductor.

A caution symbol  shall be placed on the outside of the d.c. electric vehicle supply equipment, visible to the user.

The minimum size of the protective earthing conductor shall comply with the local safety regulations and shall be indicated in the installation manual.

12.7 Dielectric Withstand Voltage

Addition:

12.7.101 Suppression of Transient Overvoltage at Input (Insulation Coordination)

When applying the test setup of Annex E of IS 17017 (Part 21/Sec 2) : 2019, with an impulse voltage according to Table F.1 of IS 15382 (Part 1) : 2014 at the input of the d.c. electric vehicle supply equipment, the d.c. electric vehicle supply equipment shall limit the output voltage to:

- a) 2 500 V between d.c. + and protective earthing conductor;
- b) 2 500 V between d.c. - and protective earthing conductor; and
- c) Output voltage of d.c. Electric Vehicle supply equipment plus 500 V, between d.c. + and d.c. -.

The d.c. electric vehicle supply equipment shall operate at its rated output voltage during the test.

Compliance is checked by applying the test setup of Annex E of IS 17017 (Part 21/Sec 2) : 2019, with a voltage according to Table F.1 of IS 15382 (Part 1) : 2014 at the input of the d.c. Electric Vehicle supply equipment.

NOTES

1 The overvoltage reduction can be achieved by combination of one or more attenuation means in accordance with 4.3.3.6 of IS 15382 (Part 1) : 2014.

2 For specification of the overvoltage category (OVC) of the primary circuit of the d.c. electric vehicle supply equipment, see 12.3 of IS 17017 (Part 1) : 2018.

12.7.102 Protection Against Transient Overvoltages of Atmospheric Origin or Due to Switching

Any power or data line cable connected to the d.c. electric vehicle supply equipment may be protected against lightning or switching events by the use of appropriate surge protective devices according to IS 16463 series. The test class and the surge/impulse current requirement (In and/or Iimp) for these devices may be determined according to the IS/IEC 62305-4. The voltage protection level (Up) for these

devices may be determined according to the requirements of IS/IEC 62305-4 : 2010, B-2.1 in conjunction with the overvoltage categories as specified in 12.3 of IS 17017 (Part 1) : 2018, when applicable.

12.11 Mechanical Strength

Replacement:

For ground mounted and wall mounted d.c. electric vehicle supply equipment in locations with restricted access, the minimum degree of protection against mechanical impact shall be IK07 according to IS 17050 : 2018.

For ground mounted and wall mounted d.c. electric vehicle supply equipment in locations with non-restricted access, the minimum degree of protection against mechanical impact shall be IK08 according to IS 17050 : 2018.

For moveable d.c. electric vehicle supply equipment under 18 kg in locations with non-restricted access, the minimum degree of protection against mechanical impact shall be IK08 according to IS 17050 : 2018.

Moveable d.c. electric vehicle supply equipment under 18 kg shall comply with 4.4.4.3 of IS/IEC 62368-1 : 2014.

Addition:

12.101 Input Current

The steady state input current of each individual charging gun of d.c. electric vehicle supply equipment shall not exceed the rated input current by more than 10 percent under the most onerous charging conditions.

Compliance is checked by measuring the input current of the d.c. electric vehicle supply equipment under the operating point (see 102.2.4) which produces the highest value of input current.

Each measurement of the input current shall be taken when the input current has stabilized.

NOTES

1 When the d.c. electric vehicle supply equipment has more than one voltage rating, the input current is measured at each voltage rating;

2 When the d.c. electric vehicle supply equipment has one or more rated voltage ranges, the input current is measured at the extremes of each rated voltage range.

12.102 Specific Requirements for Liquid Cooled d.c. EV Supply Equipment

A d.c. electric vehicle supply equipment employing liquid cooling as an element of the thermal management system shall comply with the

additional requirements for liquid cooling according to 4.7.2 of IEC 62477-1 : 2016.

12.103 Power Supply Cords

12.103.1 General

A power Supply cord of d.c. electric vehicle supply equipment shall be of the sheathed type.

Rubber sheathed power supply cords shall be of synthetic rubber and not lighter than ordinary tough rubber sheathed flexible cord according to IEC 60245-1 : 2008, designation 60245 IEC 53;

PVC sheathed power supply cords shall comply with the following:

- a) for equipment provided with a non-detachable power supply cord and having a mass not exceeding 3 kg, be not lighter than light PVC sheathed flexible cord according to IEC 60227-1 : 2007, designation 60227 IEC 52;
- b) for equipment provided with a non-detachable power supply cord and having a mass exceeding 3 kg, be not lighter than ordinary PVC sheathed flexible power supply cord according to IEC 60227-1 : 2007, designation 60227 IEC 53;

NOTE — There is no limit on the mass of the equipment if the equipment is intended for use with a detachable power supply cord.

- b) for equipment provided with a detachable power supply cord, be not lighter than light PVC sheathed flexible cord according to IEC 60227-1 : 2007, designation 60227 IEC 52.

For plug and cable d.c. electric vehicle supply equipment that has protective earthing, a protective earthing conductor shall be included in the supply cord.

Compliance is checked by inspection.

12.103.2 Cross Sectional Area

The supply cords shall have conductors with cross-sectional areas not less than those specified in [Table 7](#).

Compliance is checked by inspection.

12.103.3 Cord Anchorages and Strain Relief for Non-Detachable Power Supply Cords — Cord strain relief

12.103.3.1 General

Protective measures against strain being transmitted to the equipment terminations of the conductors of the supply cord are specified below.

A knot shall not be used as a strain relief mechanism.

A screw that bears directly on the cord or cable shall not be used as a strain relief mechanism unless the **cord** anchorage, including the screw, is made of insulating material and the screw is of comparable size to the diameter of the cord being clamped.

When a pull force and a torque are applied to a non-detachable power supply cord or cable, a basic safeguard shall minimize strain from being transmitted to the cord or cable terminations.

The pull force applied to the cord or cable is specified in [Table 12](#). The force is applied in the most unfavourable direction for 1 s and repeated 25 times.

A torque of 0.25 Nm is applied for 1 min to the cord or cable immediately after the pull force application. The torque is applied as close as practicable to the strain relief mechanism and is repeated in the opposite direction.

Compliance is determined by measurement and visual inspection. There shall be no damage to the cord or conductors and the displacement of the conductors shall not exceed 2 mm. Stretching of the cord outer jacket without displacement of the conductors is not considered displacement.

12.103.3.2 Strain relief mechanism failure

If the basic protective measure (strain relief mechanism) should fail and strain is transmitted to the non-detachable power Supply cord or cable terminations, a supplementary protective measure shall ensure that the earth termination is the last to take the strain.

Compliance is determined by inspection and, if necessary, by defeating the basic protective measure and inspecting the conductor slack while applying the force in [Table 8](#).

12.103.3.3 Cord sheath or jacket position

The cord or cable sheath or jacket shall extend from the basic safeguard (strain relief mechanism) into the equipment at least one-half the diameter of the cord or cable.

Compliance is checked by inspection.

12.103.3.4 Strain relief and cord anchorage material

The cord anchorage shall either be made of insulating material or have a lining of insulating material complying with the requirements for basic insulation. Where the cord anchorage is a bushing that includes the electrical connection to the screen of a screened power cord, this requirement shall not apply.

Table 7 Sizes of Conductors of Power Supply Cord(Clause [12.103.2](#))

SI No.	Rated Current of the Equipment ^a upto and Including	Minimum Conductor Sizes Cross-Sectional Area
(1)	A (2)	mm ² (3)
i)	3	0.5 ^b
ii)	6	0.75
iii)	10	1.00 (0.75) ^c
iv)	16	1.50 (1.0) ^d
v)	25	2.5
vi)	32	4
vii)	40	6
viii)	63	10
ix)	80	16
x)	100	25
xi)	125	35
xii)	160	50
xiii)	190	70
xiv)	230	95
xv)	260	120
xvi)	300	150
xvii)	340	185
xviii)	400	240
xix)	460	300

NOTES

1 IEC 60320-1 specifies acceptable combinations of appliance couplers and flexible cords, including those covered by footnotes ^{b, c, d}. However, a number of countries have indicated that they do not accept all of the values listed in this table, particularly those covered by footnotes ^{b, c, d}.

2 For higher currents, *see* the IEC 60364 series.

Table 8 Cord Strain Relief Pull Force(Clause [12.103.3.1](#))

SI No.	Mass of the Equipment	Force
(1)	kg (2)	N (3)
i)	Up to and including 1	30
ii)	Over 1 up to and including 4	60
iii)	Over 4	100

^a The rated current includes currents that can be drawn from a socket outlet providing mains power for other equipment.

^b For rated current up to 3 A, a nominal cross-sectional area of 0.5 mm² may be used in some countries provided that the length of the cord does not exceed 2 m.

^c The value in parentheses applies to detachable power supply cords fitted with the connectors rated 10 A in accordance with IEC 60320-1 (types C13, C15, C15A and C17) provided that the length of the cord does not exceed 2 m.

^d The value in parentheses applies to detachable power supply cords fitted with the connectors rated 16 A in accordance with IEC 60320-1 (types C19, C21 and C23) provided that the length of the cord does not exceed 2 m.

If the basic protective means (strain relief mechanism) is made of polymeric material or if the basic protective means is mounted in an enclosure consisting of polymeric material, the basic protective means shall retain its structural properties following the mould stress relief according to [12.104](#).

Compliance is determined by inspection and by applying the force and torque tests of [12.103.3.1](#) after the basic protective means has come to room temperature.

12.104 Stress Relief Test

Stress relief is checked by the mould stress relief test of IEC 60695-10-3 or by the test procedure described below or by the inspection of the construction and the available data where appropriate.

One sample consisting of the complete equipment, or of the complete enclosure together with any supporting framework, is placed in a circulating air oven at a temperature 10 K higher than the maximum temperature observed on the sample during the heating test of [12.108.2.2](#), but not less than 70 °C, for a period of 7 h, then cooled to room temperature.

For large equipment where it is impractical to condition a complete enclosure, a portion of the enclosure representative of the complete assembly with regard to thickness and shape, including any mechanical support members, may be used.

NOTE — Relative air humidity need not be maintained at a specific value during this test.

12.105 Abnormal Operation and Simulated Fault Condition Tests

12.105.1 General

Protection against the risk of thermal, electric shock and energy hazards in the case of an abnormal operating or simulated fault condition of d.c. electric vehicle supply equipment shall be evaluated by tests defined in this clause. Testing may be performed on sub-assemblies while positioned and operated under end use conditions.

Simulated abnormal operating and fault conditions shall be applied one at a time. Faults that are a direct consequence of a simulated fault or abnormal operating condition are considered to be a part of that simulated fault or abnormal operating condition.

Cheese cloth and/or surgical cotton are to be used as indicators for risk of fire. These indicators shall be placed at all openings on the outside of the enclosure in a manner which will not significantly affect cooling.

Where the installation manual requires external means of protection against faults, these specific means shall be provided for the test.

The voltages of accessible SELV circuits as well as accessible earthed and unearthed conductive parts shall be monitored.

The test shall be performed until terminated by activation of a protective device or mechanism (internal or external), a component failure occurs that interrupts the fault condition, temperatures stabilize, or a risk of fire and/or electric shock hazard occurs.

12.105.2 Pass Criteria

As a result of testing, the d.c. electric vehicle supply equipment shall comply with the following:

- a) there shall be no emission of flame, burning particles or molten metal;
- b) the cheese cloth or surgical cotton indicator shall not have ignited;
- c) the earth connection and protective equipotential bonding shall not have opened;
- d) doors and covers shall remain in place;
- e) during and after the test, accessible SELV circuits and accessible conductive parts shall not exhibit voltages exceeding the touch voltages specified in 12.6 of IS 17017(Part 1);
- f) dielectric withstand voltage test specified in [12.7](#) of IS 17017(Part 1);
- g) devices/components used for the mounting of live parts shall not break away from their initial position; and
- h) no conductor shall be pulled out of its terminal conductor.

The d.c. electric vehicle supply equipment is not required to be operational after testing and it is possible that the enclosure can become deformed. Overcurrent protection integral to the d.c. electric vehicle supply equipment, or specified by the installation manual to be used with the equipment is allowed to open.

12.105.3 Output Short-Circuit Test

The d.c. output of the charging cable shall be connected to an appropriate switching means that will not limit the short circuit current.

The equipment under test shall be supplied with mains power and the output shall be connected to an artificial load with a dedicated electric vehicle simulator for each system and operated under rated output conditions prior to closing the switching means that causes the short circuit.

Compliance is checked by application of the pass criteria in [12.105.2](#). This test is not applicable to System C.

12.105.4 Breakdown of Components Test

12.105.4.1 Load conditions

The breakdown of a component, identified by circuit analysis, shall be tested with the d.c. electric vehicle supply equipment connected to an artificial load with a dedicated electric vehicle simulator for each system at full load or light load whichever creates the more severe condition.

Testing may be conducted using the sub-assembly in which the identified component is located. In this case, the sub-assembly shall be loaded to simulate normal operating conditions.

12.105.4.2 Application of short circuit or open circuit

The short circuit shall be applied with test leads of a cross section appropriate for the current that normally flows through the component, but not less than 2.5 mm². Then length of the loop shall be as short as practical to perform the test. Short circuits and open circuits are applied using an appropriate switching device.

Each identified component shall be subjected to only one simulation of breakdown unless both open- and short circuit failure modes are likely in that component.

12.105.4.3 Test sequence

For the breakdown of components test, identified components shall be short circuited or open circuited, whichever creates the worst hazard, one at a time.

Compliance is checked by the application of the pass criteria in [12.105.2](#). In addition, during and after the application of the short circuit or open circuit, any flame inside the equipment shall extinguish within 10 s and no surrounding parts shall have ignited.

12.105.5 Loss of a.c. Supply Phase Test

A multi-phase d.c. electric vehicle supply equipment shall be operated with each phase (including neutral, if used) disconnected in turn at the supply input. The test shall be performed by disconnecting one phase with the equipment connected to an artificial load with a dedicated Electric Vehicle simulator for each system operating at maximum rated output. The test is repeated by initially energizing the d.c. electric vehicle supply equipment with one lead disconnected.

The test shall continue until terminated by a protective mechanism, a component failure occurs, or the temperature stabilizes.

Compliance is checked by the application of the pass criteria in [12.105.2](#).

12.105.6 Inoperative Blower/Fan Motor Test

d.c. electric vehicle supply equipment having forced ventilation shall be connected to an artificial load with a dedicated electric vehicle simulator for each system while operating at maximum rated current and power output with fan or blower motor or motors made inoperative either singly or in combination from a single fault. The fan or blower motor shall be made inoperative by either physically preventing rotation or by disconnecting its power source.

Compliance is checked by the application of the pass criteria in [12.105.2](#).

12.105.7 Clogged Filter Test

d.c. electric vehicle supply equipment having filtered ventilation openings shall be connected to an artificial load with a dedicated electric vehicle simulator for each system while operating at maximum rated current and power output with the openings blocked to represent clogged filters. The test shall be performed initially with 50 percent of the ventilation openings surface blocked. The test shall be repeated under a full blocked condition.

Compliance is checked by the application of the pass criteria in [12.105.2](#).

12.106 Protection Against Electrically Caused Fire

12.106.1 General

The protective measure to reduce the risk of the spread of fire under normal operating conditions and single fault conditions to the environment from within is two-fold:

- a) implementation of a fire enclosure; and
- b) selection of internal combustible parts with a low flammability classification.

NOTE — Normally, abnormal operating and fault condition testing (for example, open- and short-circuit of electronic components) would be required to demonstrate the potential risk of fire. However, this protective measure is designed to facilitate the use of low flammability classification internal materials and a fire enclosure (external or internal or a combination of both) to provide containment of fire originating from within.

12.106.2 Fire Enclosure

Fire enclosures are used to reduce the risk of the spread of fire to the environment from within, independent of the location where they are installed. An overall fire enclosure shall be provided for d.c.

electric vehicle supply equipment unless internal fire enclosure(s) are provided.

The fire enclosure shall be designed according to **4.6.3** of IEC 62477-1 : 2016. Flammability of fire enclosure materials in d.c. electric vehicle supply equipment shall be according to **4.6.3.2** of IEC 62477-1 : 2016.

For general information on openings of fire enclosures, *see* **4.6.3.3.1** of IEC 62477-1 : 2016.

Openings in the top surface of the fire enclosure shall be according to **4.6.3.3.2** of IEC 62477-1 : 2016, and the corresponding test shall comply with **5.2.2.2** of IEC 62477-1 : 2016.

Openings in the sides of the fire enclosure shall be according to **4.6.3.3.2** of IEC 62477-1 : 2016.

Openings in the bottom of the fire enclosure shall be according to **4.6.3.3.3** of IEC 62477-1 : 2016.

The flaming oil test shall comply with **5.2.5.6** of IEC 62477-1 : 2016.

Fire enclosure bottom openings for ground mounted d.c. electric vehicle supply equipment in fixed installations shall comply with **6.4.8.3.5** of IEC 62368-1 : 2014.

Doors or covers in fire enclosures shall comply with **4.6.3.3.4** of IEC 62477-1 : 2016.

Materials for components that fill an opening in a fire enclosure shall comply with **4.6.3.2** of IEC 62477-1 : 2016 or with IS/IEC 60695-11-10 flammability requirements for V-1 material.

Provision of internal fire enclosure(s) as the protective measure against the spread of electrically-caused fire leads to consideration of any external combustible parts, for example, decorative in function, located outside of the internal fire enclosure and not required as part of the protective measure. These external parts are not required to meet the - 5 VA flammability class requirement and need only have a V-2 minimum classification.

Internal fire enclosure construction and internal combustible material considerations are the same as described.

Combustible materials located within the fire enclosure shall comply with **4.6.2.2** of IEC 62477-1 : 2016.

Compliance is checked by inspection.

12.107 Protection Against Chemical Hazards

12.107.1 Type of Coolant

The liquid coolant utilized shall be non-hazardous to the environment according to the globally

Harmonized system for the classification and labelling of chemicals. The biodegradability of the liquid coolant shall be ≥ 60 percent tested according to OECD 301 B and stated into the data sheet.

Warnings shall be provided in the installation manual or data sheet indicating that leaking or material degradation shall occur if a coolant other than that specified by the manufacturer is used.

Compliance is checked by inspection.

12.107.2 Environmental Considerations

The liquid coolant utilized shall be non-hazardous in accordance with local regulations. The liquid coolant shall be non-hazardous for the environment or shall be used in a manner such that any spills are contained within the equipment and isolated against the environment in accordance to the local regulations.

Environmental safety data sheet shall be provided for all specified liquid coolant approved the cable assembly manufacturer.

Compliance is checked by inspection.

12.107.3 Flammability

The liquid coolant shall not lead to a fire hazard if leaked onto exposed electrical parts. The minimum flashpoint of the liquid coolant shall be 135 °C.

Compliance is checked by inspection of the material safety data sheets or by the test according to ISO 2719.

12.107.4 Conductivity

The d.c. electric vehicle supply equipment already has protection against electric shock, for example, insulation monitoring device (IMD, System C) or leakage current device. Also, during normal operation, no leakage of coolant is allowed (*see* [12.102](#)). Therefore, no requirements or tests shall be necessary for the conductivity of the liquid coolant.

12.107.5 Material Compatibility

All liquid coolant confining parts of the liquid handling system shall be resistant to the action of the liquid coolant and shall not degrade over time due to the exposure to heat. Non-metallic parts shall be able to maintain their physical properties after being exposed to the liquid coolant and air oven ageing as follows:

Compliance is checked by the tests of [12.107.5.1](#), [12.107.5.2](#), and [12.107.5.3](#).

12.107.5.1 Air oven aging plastic parts and gaskets

Six specimens are aged in an air circulating oven at 121 °C for 7 days and shall maintain the physical

properties of tensile strength and elongation. The tensile strength and ultimate elongation shall not be less than 60 percent of the tensile strength and ultimate elongation of the as-received sample. The test method of IEC 60811-501 shall be followed.

12.107.5.2 Liquid coolant exposure

Other specimens are to be immersed in the liquid coolant at $(80 \pm 2.0)^\circ\text{C}$ for 70 ± 0.5 h.

Six samples of each material, 25.4 mm wide and 203 mm long and not thicker than the thinnest part in the application are required for this test. Three are tested as-received and three are tested following immersion.

The tensile strength and ultimate elongation shall not be less than 60 percent of the tensile strength and ultimate elongation of the as-received samples.

12.107.5.3 Creep resistance test

Two samples of each non-metallic part of the liquid coolant confining system shall be conditioned for 14 days at a temperature of 87°C and placed in a full draft air-circulating oven. Following the conditioning, the parts shall show no sign of deterioration such as cracking and embrittlement.

12.108 Enclosures

12.108.1 General

Enclosures shall be designed according to **4.12** of IEC 62477-1 : 2012 except for the requirements for IP degrees in **12.4**.

12.108.2 Strength of Materials and Parts

12.108.2.1 General

Strength of materials and parts of d.c. Electric Vehicle supply equipment shall be according to **10.2** of IEC 61439-7 : 2018.

The d.c. electric vehicle supply equipment shall be constructed of materials capable of withstanding the mechanical, electrical, thermal and environmental stresses that are likely to be encountered in anticipated service conditions.

12.108.2.2 Properties of insulating materials — Thermal stability

For enclosures or parts of enclosures made of insulating materials, thermal stability shall be verified by the dry heat test.

Compliance is checked by inspection and test in accordance with **10.2.3.1** of IEC 61439-1.

12.108.2.3 Properties of insulating materials — Resistance to heat and fire

Resistance of insulating materials to heat and fire shall be according to **8.1.3.2** of IEC 61439-1 : 2011.

Compliance is checked by inspection of manufacturer's test data or test.

12.108.3 Enclosure Integrity Tests

The enclosure integrity tests shall be according to **5.2.2.4** of IEC 62477-1 : 2016.

NOTE — The enclosure integrity tests specified in IEC 62477-1 : 2012 include the tests for deflection, steady force, impact, drop, stress relief, stability, wall or ceiling mounted equipment, handles, and manual controls securement test.

12.109 Components Bridging Insulation

12.109.1 General

Components bridging insulation shall comply with the requirements of the level of insulation, for example, basic, reinforced or double, they are bridging.

12.109.2 Isolating Transformers

Isolating transformers, excluding safety isolating transformers used for signalling, shall comply with the requirements of G-5.3 of IEC 62368-1 : 2014 or IEC 61558-1 and IEC 61558-2-4.

Compliance is checked by inspection.

12.109.3 Capacitors

Capacitors bridging isolation barriers shall comply with ISO/QC 302400.

13 OVERLOAD AND SHORT CIRCUIT PROTECTION

This clause of IS 17017 (Part 1) is applicable except as follows:

Replacement:

13.2 Overload Protection of the Cable Assembly

Not applicable.

13.3 Short-Circuit Protection of the Charging Cable

Not applicable.

Addition:

13.101 Short-Circuit Protection of the d.c. Connection

For a short-circuit supplied by the d.c. electric

vehicle supply equipment, the d.c. electric vehicle supply equipment shall fulfill all of the following requirements:

- a) limit the peak current, including transient effects, to 10 kA or less at the contacts of the vehicle connector for System C;
- b) limit the I^2t value to 1 000 000 A²s or less at the contacts of the vehicle connector for System C;
- c) trigger an emergency shutdown within 1 s after the start of the short-circuit condition for System C;
- d) disable its d.c. output until the d.c. electric vehicle supply equipment has been inspected and repaired, if needed;
- e) The power supply circuit of the d.c. electric vehicle supply equipment shall have a short-circuit current withstand rating (I^2t) according to the values as specified in ISO DIS 17409 : 2019 for the different systems. The minimum cross-sectional area of the line conductors shall be calculated according to equation (3) of IS 732 : 2019; and
- f) An overcurrent protection device shall be provided in the power supply circuit of the d.c. electric vehicle supply equipment. The overcurrent protection device shall withstand a peak current according to the values as specified in ISO 17409 : 2020 for the different systems. The section of the power supply circuit which is protected by this protection device shall be designed according to the characteristics of this over-current protection device. The section of the power supply circuit which is not protected by this over-current protection device shall comply with requirement e).

For System C, the compliance is tested according to [A-9.3.18](#).

For a short-circuit supplied by the electric vehicle, the requirements in e) or f) shall be fulfilled.

If the short-circuit current supplied by the d.c. electric vehicle supply equipment is not sufficient

to trip a fuse, if any, within the required time to limit the I^2t value, the d.c. electric vehicle supply equipment shall provide an alternative means to interrupt the short-circuit current.

NOTE — The current peak is a result of the discharge of the capacitance of the d.c. electric vehicle supply equipment.

The capacitive discharge is a transient phenomenon in the range of milliseconds.

14 AUTOMATIC RECLOSING OF PROTECTIVE DEVICES

This clause of IS 17017 (Part 1) is not applicable except for plug and cable connected d.c. electric vehicle supply equipment.

15 EMERGENCY SWITCHING OR DISCONNECT (OPTIONAL)

This clause of IS 17017 (Part 1) is applicable.

16 MARKING AND INSTRUCTIONS

This clause of IS 17017 (Part 1) is applicable except as follows:

16.1 Installation Manual of EV Charging Stations

Addition:

For Systems C,

- a) If coolant is used, for example, for thermal management system, the installation manual of the d.c. electric vehicle supply equipment shall include information about the coolant properties according to **101.2** of IEC TS 62196-3-1;
- b) A standard sign “refer to instruction manual” according to ISO 7010 shall be visibly attached to the thermal exchange; and
- c) The name of the coolant shall be visible attached at the enclosure of the cooling unit.

Compliance is checked by inspection.

For d.c. electric vehicle supply equipments intended for fixed installation, the installation manual shall include information about the protective measure to be provided by the installations. If under normal and fault conditions any resulting d.c. component of the current in the protective conductor may exceed 6 mA, a caution notice and the symbol W001 of IS 16451 shall be provided in the installation manual, and the symbol shall be placed on the product. The caution notice shall be

CAUTION — This product can cause a d.c. current in the protective conductor. Where a residual current-operated protective device (RCD) is used for protection against electrical shock, only an RCD of Type B is allowed on the supply side of this product. or equivalent (*see* **6.3.7.5** and **4.4.8** of IEC 62477-1 : 2016).



NOTE — Symbol denotes caution, please refer to documentation.

The manufacturer shall recommend a preventative maintenance program for the replacement of the cable assembly following, for example, a predetermined period of time in service and/or number of charging sessions.

Compliance is checked by inspection of the program established by the manufacturer.

16.4 Marking of Charging Cable Assemblies Case B

Not applicable.

Addition:

101 SPECIFIC REQUIREMENTS FOR d.c. EV SUPPLY EQUIPMENT

101.1 Protection Against Uncontrolled Reverse Power Flow from Vehicle

The d.c. electric vehicle supply equipment shall be equipped with a protective means against the uncontrolled reverse power flow from vehicle. Uncontrolled power flow does not include instantaneous reverse power flow, which may occur with closing of contactors within the tolerances and duration specified in [A-6.2](#).

101.2 Specific Requirements for Isolated Systems

101.2.1 Operating Ranges for Output Voltage, Output Current, and Output Power

The manufacturer of the d.c. electric vehicle supply equipment shall specify the operating range using the following parameters and indicate them in the user manual and the installation manual:

- a) output voltage range [V_{Min} , V_{Max}];
- b) output current range [I_{Min} , I_{Max}];
- c) maximum output power P_{Max} ;
- d) ambient operating temperature range; and
- e) maximum operating altitude above sea level.

NOTE — IS 17017 (Part 24) specifies the parameters which shall be communicated to the Electric Vehicle using digital communication in a specified manner.

The ambient operating temperature range shall at least cover the range from $-5\text{ }^{\circ}\text{C}$ to $+55\text{ }^{\circ}\text{C}$.

The maximum operating altitude above sea level shall not be less than 1 000 m above sea level.

The manufacturer of the dual gun d.c. electric vehicle supply equipment may specify one or more additional operating ranges of the d.c. electric vehicle supply equipment by specifying:

- a) an ambient operating temperature range wider than the one referred to above; and/or
- b) a maximum operating altitude above sea level higher than the one referred to above.

In such a case, the other parameter ranges applicable for those/this additional operating range(s) may deviate from the ones referred to above, for example, as under:

- a) an output voltage range smaller than the one referred to above; and/or
- b) an output current range smaller than the one referred to above; and/or
- c) a maximum output power smaller than the one referred to above.

The d.c. electric vehicle supply equipment shall be able to provide electrical energy with an output quality as specified in [101.2.2](#) within each operating range specified in such a way, in particular with the output voltage request from the electric vehicle being in the range [V_{Min} , V_{Max}] and the output current request from the electric vehicle being in the range [I_{Min} , I_{Max}], and the output power not exceeding P_{Max} .

The d.c. electric vehicle supply equipment shall not exceed its specified maximum output power, even if the power requested by the electric vehicle is beyond the maximum output power of d.c. electric vehicle supply equipment.

The d.c. electric vehicle supply equipment may also be able to operate below the lower limit of a specified operating range, that is provide output current less than given by I_{min} or output voltage less than given by V_{Min} , without the need to fulfil all requirements given in [101.2](#).

101.2.2 Output Voltage and Current Tolerance

101.2.2.1 Output current regulation in CCC

Requirements for output current regulation in CCC are specified in [A-6.4](#).

Compliance for System C is checked by [A-9.3.12](#).

101.2.2.2 Output voltage regulation in CVC

For CVC, the maximum voltage deviation during pre-charge state and during charging of the vehicle/traction battery shall not exceed ± 5 percent of the requested voltage, or ± 2 percent of the maximum rated voltage of the d.c. electric vehicle supply equipment, whichever deviation is smaller (see [Fig. 10](#)).

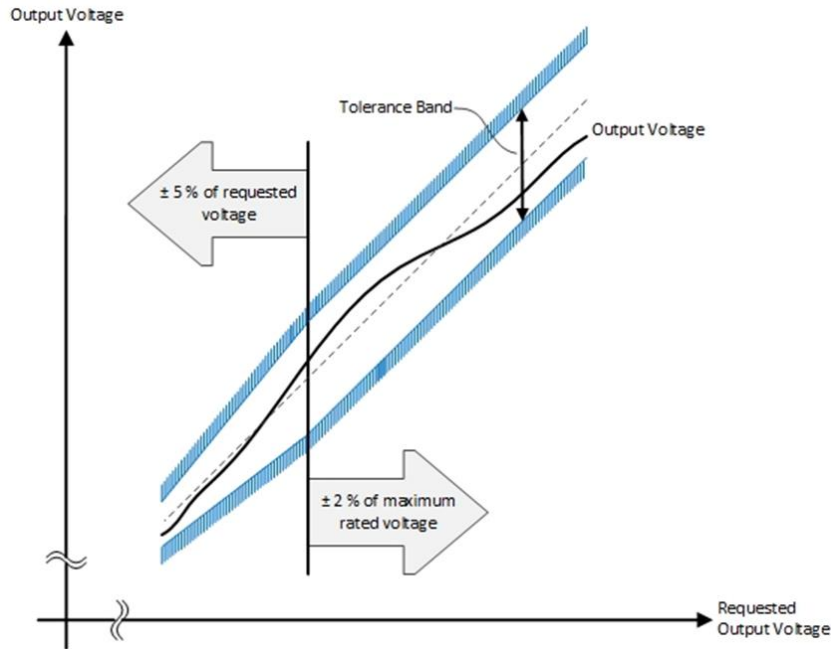

FIG. 10 VOLTAGE TOLERANCES

These requirements are for System C.

Compliance is checked by the tests in [A-9.3.13](#).

NOTES

1 The current ripple is not specified within the CVC mode as it depends on the impedance between the d.c. output and the electric vehicle battery, which is not defined in ISO 17409.

2 The current requirements of CCC mode like regulation (see [101.2.2.1](#)) and control delay (see [101.2.3](#)) are not applicable in CVC mode, which leads to undefined current behaviour within the CVC mode.

The electric vehicle can prevent the d.c. electric vehicle supply equipment from unintentionally entering the CVC mode during charging as this can lead to large current ripples when the battery is attached or it can lead to no current if the requested voltage minus the voltage deviation is below the battery voltage. When the electric vehicle battery is attached to the d.c. output, the CVC mode can be avoided by requesting a voltage of at least $V_{Compensation}$ above the battery voltage.

$$V_{EV\ target} > V_{Compensation} + V_{Battery}$$

$$V_{Compensation} = V_{Deviation} + V_{rip} + V_{EV_drop} + V_{Margin}$$

$$V_{Deviation} = \min(2\ \text{percent} \times V_{Rated}, 5\ \text{percent} \times V_{EV\ target})$$

$$V_{rip} = \max(5\ \text{V}, 1\ \text{percent} \times V_{EV\ target})$$

$$V_{EV_drop} = I_{Output} \times Z_{EV}(I_{Output})$$

where

$V_{EV\ target}$ = voltage request coming from the electric vehicle;

$V_{Compensation}$ = voltage the electric vehicle to be added to prevent CVC mode;

$V_{Battery}$ = voltage of the electric vehicle battery;

$V_{Deviation}$ = deviation on the output voltage;

V_{rip} = ripple on the d.c. output;

V_{EV_drop} = voltage drop between the d.c. output and the vehicle battery;

V_{Margin} = voltage margin chosen by the electric vehicle manufacturer;

V_{Rated} = rated output voltage of the d.c. electric vehicle supply equipment;

I_{Output} = d.c. Output current of the d.c. electric vehicle supply equipment; and

$Z_{EV}(I_{Output})$ = impedance of the electric vehicle at the d.c. output current.

$$V_{Deviation} + V_{rip} \text{ is } 30\ \text{V at } 1\ 000\ \text{V.}$$

101.2.3 Control Delay of Charging Current in CCC

The d.c. Electric Vehicle supply equipment shall control the output current within 1 s after acknowledging reception of the request from the vehicle according to IS 17017 (Part 24), with a current control accuracy specified in [101.2.2.1](#), and with a changing rate dI_{min} of 20 A/s or more.

If the vehicle requests a target current I_N , which shows deviation lower than or equal to 20 A compared to the base current value I_0 , the output current of d.c. electric vehicle supply equipment shall be within the tolerance limits given in [101.2.2.1](#) within a delay time of 1 s after acknowledging reception of the request from the vehicle according to IS 17017 (Part 24).

If the vehicle requests any target current I_N , which shows deviation higher than 20 A compared to the base current value I_0 , the output current of d.c. electric vehicle supply equipment shall be within the tolerance limits given in [101.2.2.1](#) within a delay time T_d as defined in formula (4), and as shown in [Fig. 11](#).

$$T_d \leq \frac{|I_N - I_0|}{dI_{\min}}$$

for $|I_N - I_0| \geq 20A \quad \dots(4)$

where

- T_d = control delay of charging current;
- I_N = value for the target current;
- I_0 = value for the base current, that is output

current at the time of new request; and
 dI_{\min} = minimum current change rate.
 $|I_N - I_0|$ = absolute value of the difference between I_N and I_0 .

For System C, see [A-9.3.14](#).

101.2.4 Descending Rate of Charging Current

The descending rates for error shutdown and emergency shutdown shall be according to [A-3.4](#) and [A-3.5](#) for System C.

For compliance of System C, see [A-9.3.15](#).

101.2.5 Periodic and Random Deviation (Current Ripple)

Current ripple of d.c. Electric Vehicle supply equipment during current regulation shall not exceed the limit as defined in [Table 9](#). Measurement shall be made at maximum rated power and rated current, or in the worst case where the output voltage and output current correspond theoretically to the maximum current ripple. The current ripple is not included in the tolerance defined in [101.2.2.1](#).

The artificial load according to [Fig. 17](#) shall be used.

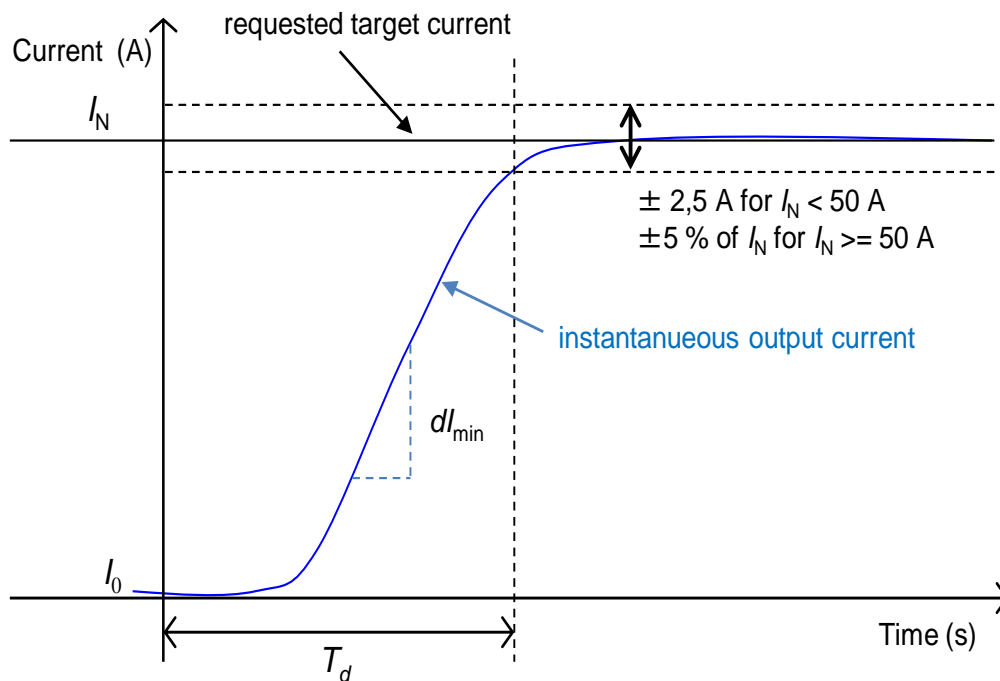

FIG. 11 STEP RESPONSE FOR CONSTANT VALUE CONTROL

Table 9 Current Ripple Limit of d.c. EV Supply Equipment

(Clause 101.2.5)

SI No.	Limit ^a	Frequency
(1)	(2)	(3)
i)	1.5 App	frequency band above 0 Hz and below 10 Hz
ii)	6 App	frequency band above 0 Hz and below 5 kHz
iii)	9 App	frequency band above 0 Hz and below 150 kHz

NOTE — The upper value of each frequency band (10 Hz, 5 kHz and 150 kHz) is the cut-off frequency (- 3.0 dB) of first order low-pass filter.

Compliance for System C is checked by [A-9.3.12](#).

101.2.6 Periodic and Random Deviation (Voltage Ripple in CVC)

For requested output voltage up to 500 V, the maximum voltage ripple in normal operation and precharge, if applicable, shall not exceed ± 5 V.

For requested output voltage above 500 V, the maximum voltage ripple in normal operation and precharge, if applicable, shall not exceed ± 1 percent of the requested Output voltage.

The maximum voltage slew rate in normal operation shall not exceed ± 20 V/ms.

For explanation of terms, see [Fig. 12](#).

Compliance is checked by the test in [A-9.3.13](#).

For CVC, when the vehicle battery is not connected: *under consideration*.

101.2.7 Load Dump

If the vehicle contactors open while the vehicle is being charged at the maximum current of the d.c.

Electric Vehicle supply equipment, the output voltage shall not exceed the limit specified for each system in [A-6.2](#).

Maximum slew rate of output voltage in case of load dump shall not exceed 250 V/ms.

Compliance for System C is checked by [A-9.3.9](#).

101.3 Specific Requirement for Multiple d.c. Outputs

The specific requirements for the multiple d.c. outputs are provided in [Annex C](#).

101.4 Specific Requirement for Charging with Thermal Management System

This clause is applicable for System C.

For charging with thermal management system, the d.c. Electric Vehicle supply equipment shall be equipped with a cable assembly according to IEC TS 62196-3-1.

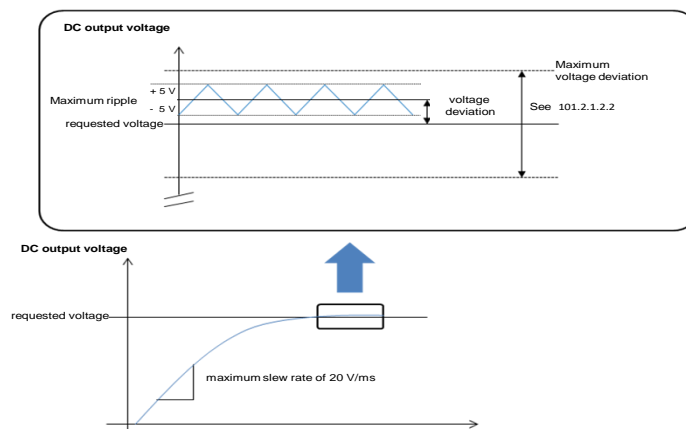

FIG. 12 MAXIMUM RATINGS FOR VOLTAGE DYNAMICS

^a difference between positive peak top and negative peak top at full scale output.

101.4.1 Temperature Limits and Self-Diagnostics

101.4.1.1 Temperature of the d.c. contact assembly of the vehicle connector

The d.c. electric vehicle supply equipment shall ensure that the temperature of the d.c. contact assembly of the vehicle connector complies with the following requirements under the operating ambient temperature up to 55 °C.

- a) The absolute temperature of the d.c. contact assembly shall not exceed 90 °C;
- b) The surface temperature of the cable assembly shall not exceed the temperature limits according to **16.5** of IS 17017 (Part 2/Sec 1); and
- c) If a thermal sensing providing temperature values is implemented in the attached vehicle connector, the d.c. electric vehicle supply equipment shall evaluate the measured values of the thermal sensing device at each d.c. contact assembly.

101.4.1.2 Requirements for self-diagnostics function for thermal management system

The d.c. electric vehicle supply equipment manufacturer shall provide a FMEA according to IEC 60812.

The d.c. electric vehicle supply equipment shall provide appropriate means to reduce the likelihood of a hazard occurring in case of a first fault in the thermal management system, for example, by double or reinforced insulation, flow rate, pressure, temperature, level of coolant, etc.

In case of a thermal exchange device or thermal transport device failure (for example, failure of cooling pump, jammed cooling hose), the d.c. electric vehicle supply equipment shall either stop operation or reduce the available current to value for operation without thermal exchange and/or thermal transport, if such a value is given by the cable assembly manufacturer. The d.c. electric vehicle supply equipment shall transmit it to vehicle via digital communication.

In case of a thermal sensing fault, *see* [101.4.2.3](#).

Compliance is checked by inspection and test in [101.4.3.4](#).

101.4.2 Temperature Monitoring

101.4.2.1 General

The d.c. electric vehicle supply equipment, using cable assembly providing thermal sensing data, shall have measures to continually monitor the provided temperature data.

The d.c. electric vehicle supply equipment shall continually monitor the temperature data of the d.c. contact assemblies during the complete charging sequence.

101.4.2.2 Overtemperature handling

If the measured temperature at one or both d.c. contact assemblies exceeds 90 °C, the d.c. electric vehicle supply equipment shall trigger an error shutdown sequence within 9 s according to [A-3.4](#) for System C.

Compliance is checked by test in [101.4.3.3](#).

If three consecutive error shutdowns occur due to temperature exceeding 90 °C at one or both d.c. contacts, the d.c. electric vehicle supply equipment shall not start a new supply process until serviced.

Compliance is checked by inspection and measurement.

101.4.2.3 Check of the plausibility of the values provided by the thermal sensing devices

A plausibility check of the thermal sensing devices of the vehicle connector shall be done prior to each charging session. If the plausibility check fails, the d.c. electric vehicle supply equipment shall:

- a) only operate under the current assigned by the manufacturer of the cable assembly for operation without thermal exchange and/or thermal transport; and
- b) not start a new supply process until serviced (for System C only).

Compliance is checked by inspection and test in [101.4.3.6](#).

If the thermal sensing of a d.c. contact assembly sends no or an implausible signal during charging, the d.c. electric vehicle Supply equipment shall:

- a) trigger an error shutdown according to [A-3.4](#) within 9 s after the occurrence of the fault.

Compliance is checked by inspection and test in [101.4.3.7](#).

101.4.3 Tests for Thermal Management System Performance of the d.c. EV supply equipment

101.4.3.1 General

For all tests, thermal stabilisation is considered to have occurred when three successive readings, taken at intervals not less than 10 min, indicate no increase greater than 2 K.

The test current is the rated current according to the device under test (DUT) manufacturer’s data sheet, if not stated otherwise.

The DUT for these tests is the d.c. electric vehicle supply equipment.

A system specific vehicle simulator equipped with a current sink shall be used for all tests in this clause.

Each test shall be performed with a corresponding test accessory, called reference device (RD), which mates with the vehicle connector.

The material for all reference devices shall be Cu-ETP.

For System C, all tests, except the test of overtemperature handling according to [101.4.3.3](#), shall be performed with a RD according to [Fig. 13](#) and a test arrangement according to [Fig. 14](#). The test for overtemperature handling according to [101.4.3.3](#) shall be performed with a RD according to [Fig. 15](#) and a test arrangement according to [Fig. 17](#).

The contact resistances of the reference devices, including d.c. contact, contact body, mechanical joining and 150 mm of the attached conductor, measured by four-terminal sensing according to [Fig. 13](#) shall comply with the values indicated in [Table 10](#).

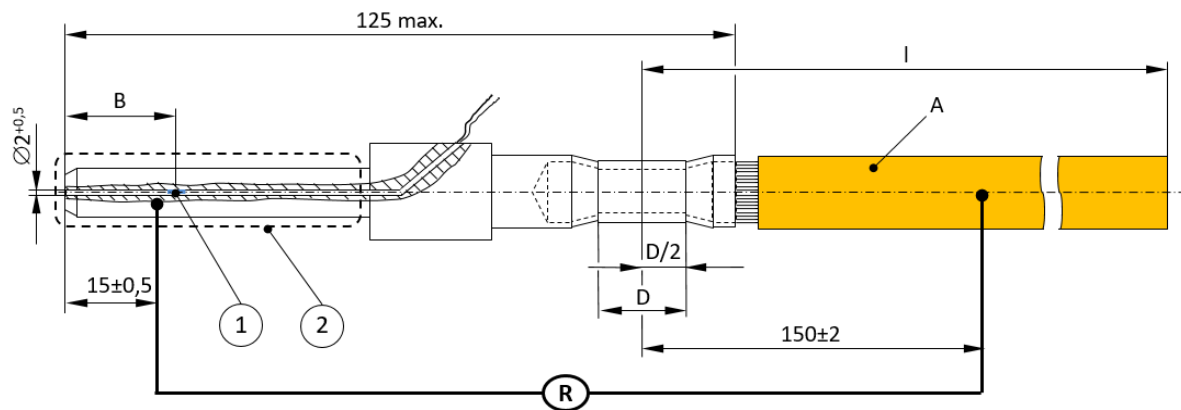

Key

- ① Reference temperature sensor
- ② d.c. power contact according to standard sheet 3-IVa (configuration FF) of IS 17017 (Part 2/Sec 3)
- A Conductor cross-section (depending on the test current, see [Table 15](#)) 
- B 18 mm ± 1 mm for configuration FF
- D To be determined by the manufacturer
- l Length of attached conductor (see [Table 15](#))
- R Resistance measurement (see [Table 15](#) for values)

FIG. 13 REFERENCE DEVICE C_0



Key

- ① Reference device C_0
- ② DUT
- ③ d.c. electric vehicle Supply equipment with thermal exchange and thermal transfer, if any
- ④ Vehicle simulator with current sink
- A Conductor cross-section (depending on the test current, *see* Table 15)
- l Length of attached conductor (*see* Table 15)
- I_{Test} Test current
- T_S+, T_S- Thermal sensing device inside vehicle connector at d.c. + and d.c. -

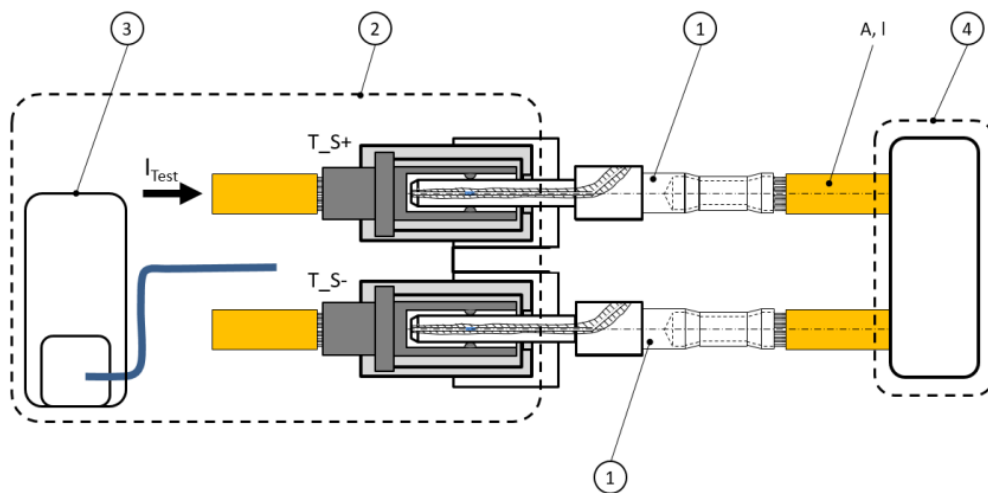
FIG. 14 TEST ARRANGEMENT C_0

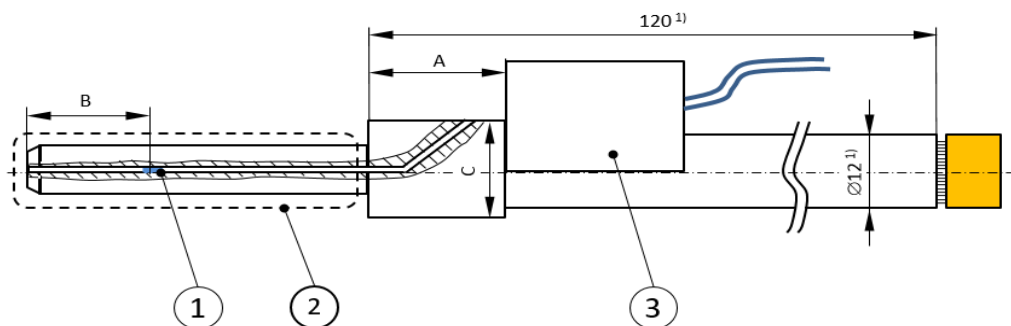

Key

- ① Reference temperature sensor
- ② d.c. power contact according to standard sheet 3-IVa (configuration FF) of IS 17017 (Part 2/Sec 3) : 2020
- ③ Heating unit
- A To be determined by the manufacturer
- B 18 ± 1 mm for configuration FF
- C To be determined by the manufacturer

¹⁾ The diameter and length of termination ($\text{Ø}12$ and 120) are recommended values.

FIG. 15 REFERENCE DEVICE C_1

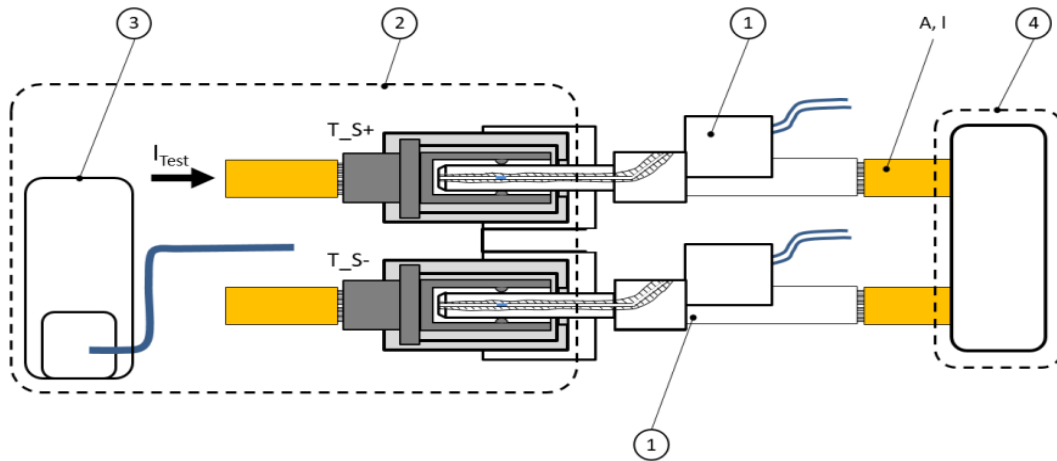

Key

- ① Reference device C_0
- ② DUT
- ③ d.c. Electric Vehicle Supply equipment with thermal exchange and thermal transfer, if any
- ④ Vehicle simulator with current sink
- A Conductor cross-section (depending on the test current, see Table 15)
- l Length of attached conductor (see Table 15)
- I_{Test} Test current
- T_{S+}, T_{S-} Thermal sensing device inside vehicle connector at d.c.+ and d.c.-

FIG. 16 TEST ARRANGEMENT C_1

Values for wiring cross section and cable length are specified in [Table 10](#).

Table 10 Values for Parameter A, L and R

(Clause [101.4.3.1](#))

Sl No.	Parameter	Description	Value	Rated current (A Max)	Resistance ($\mu\Omega$)
(1)	(2)	(3)	(4)	System C (5)	System C (6)
i)	A	Conductor cross section	35 mm ²	100	(under consideration)
ii)			50 mm ²	200	123 to 128
iii)			60 mm ²	250	91 to 96
iv)			70 mm ²	300	
v)			95 mm ²	400	65 to 70
vi)			120 mm ²	500	57 to 62
vii)			150 mm ²	-	
viii)	l	Cable length	2 m	-	

101.4.3.2 Thermal management system performance test

This test is applicable for d.c. electric vehicle supply equipments according to System C using a thermal management system.

For System C, the test is performed with a RD according to [Fig. 13](#) and a test arrangement according to [Fig. 14](#).

The DUT shall be stored for at least 2 h at $(55 \pm 4) ^\circ\text{C}$.

The test shall be executed at rated current and may be executed at the minimum output voltage of the DUT.

Once thermal stabilisation has been reached, the DUT shall be operated at rated current and may be operated at the minimum output voltage for an additional 60 min.

Then the current shall be reduced to less than 2 A.

The temperatures measured by the reference temperature sensors of the reference devices shall be monitored with one or more samples per second throughout the test.

This test is passed, if:

- a) the d.c. electric vehicle supply equipment performs the supply process without any errors;
- b) the measured temperatures by the reference temperature sensors do not exceed 90 °C; and
- c) the temperature limits according to **16.5** of IS 17017 (Part 2/Sec 1) : 2020 are not exceeded at any touchable and graspable surface of the DUT (for system C only).

101.4.3.3 Tests of overtemperature handling

This test is applicable for d.c. electric vehicle supply equipment according to System C.

For System C, the test is performed with a RD according to [Fig. 15](#) and a test arrangement according to [Fig. 16](#).

The DUT shall be stored for at least 2 h at 55 °C ± 4 °C

The test shall be executed at rated current and may be executed at the minimum Output voltage of the DUT.

The test shall be executed as follows:

- a) Once thermal stabilization has been reached, the over-temperature of the vehicle connector is stimulated by applying heat power ensuring a constant temperature rise of 2.5 K/min ± 0.5 K/min (measured by the reference temperature sensor) on the d.c. + contact;
- b) The test shall be stopped if the temperature as measured by the reference temperature sensor reaches 95 °C; and
- c) The test shall be repeated with applying heat power on the d.c. – contact

This test is passed, if one of the following requirements is fulfilled:

- a) The d.c. electric vehicle supply equipment performs an error shutdown sequence

according to [A-3.4](#) for System C within 9 s after the reference temperature sensor signals a temperature of more than 90 °C; or

- b) The d.c. electric vehicle supply equipment reduces the output current (less than 2 A) before the temperature measured by the reference temperature sensor reaches 90 °C.

The test shall be performed two consecutive times.

101.4.3.4 Test for self-diagnostics function for thermal management system

For System C, the test is performed with a RD according to [Fig. 13](#) and a test arrangement according to [Fig. 14](#).

The DUT shall be stored for at least 2 h at 55 °C ± 4 °C.

The test shall be executed at rated current and may be executed at the minimum output voltage of the DUT.

The test shall be executed for the following test sequences:

- a) Once thermal stabilization has been reached, the thermal transport device, for example, cooling pump, shall be switched off; and
- b) Once thermal stabilization has been reached, the thermal exchange device, for example, cooling unit, shall be switched off.

After switching off the corresponding device, the DUT shall be operated for an additional 60 min.

This test is passed if:

- a) the measured temperatures by the reference temperature sensors do not exceed 90 °C; and
- b) the temperature limits according to **16.5** of IS 17017 (Part 2/Sec 1) : 2020 are not exceeded at any touchable and graspable surface of the DUT (for System C only)

NOTE — Pass criteria can be achieved by reducing the available output current.

101.4.3.5 Test for availability of thermal sensing devices — General

For System C, the test is performed with a RD according to [Fig. 13](#) and a test arrangement according to [Fig. 14](#).

The DUT shall be equipped with a disconnecting device in each signalling path of thermal sensing.

Tests shall be conducted for each of the following test setups:

- a) signalling path of thermal sensing on d.c. + contact open and signalling path of thermal sensing on d.c. – contact closed; and
- b) signalling path of thermal sensing on d.c. + contact closed and signalling path of thermal sensing on d.c. – contact open.

101.4.3.6 *Test for availability of thermal sensing devices before charging*

The availability of each thermal sensing device shall be checked before each charging session.

After setting the disconnecting devices in the positions according to [101.4.3.5](#), a charging session shall be initiated.

This test is passed if the DUT does not start a supply process until serviced (for System C only).

101.4.3.7 *Test for availability of thermal sensing devices during charging*

The DUT shall be operated at rated current and may be operated at the minimum output voltage.

Then the disconnecting devices shall be set in the positions according to [101.4.3.5](#).

This test is passed if:

- a) trigger an error shutdown according to [A-3.4](#) within 9 s after the occurrence of the fault (for System C only)

101.5 Specific Requirements for Temperature Controlled Charging

The d.c. electric vehicle supply equipment may allow a boost current exceeding the rated current of the cable assembly based on agreement between cable assembly manufacturer and d.c. electric vehicle supply equipment manufacturer as long as the temperature requirement of the d.c. contact assembly according to [101.4.1.1](#) is fulfilled for the condition required by the d.c. electric vehicle supply equipment manufacturer. The boost current shall not exceed the maximum rated current for each system according to Table 108 in IEC TS 62196-3-1 : 2020.

Temperature controlled charging shall be mutually agreed between manufacturers of the d.c. electric vehicle supply equipment and the cable assembly.

Compliance is checked by inspection and test in [101.4.3.2](#).

This clause is applicable for System C.

102 TEST REQUIREMENTS

102.1 Technical Data

The following information from the manufacturer shall be provided for compliance test:

- a) operating points ([102.2.4](#));

- b) operating temperature range;
- c) operating humidity range; and
- d) a.c. supply voltage.

In addition to above, the information on additional operating points with a maximum output ripple, if any, shall be provided for System C.

102.2 General Test Conditions

102.2.1 *Ambient Test Conditions*

102.2.1.1 *Environmental conditions*

Unless otherwise specified, all tests shall be carried out under the following test conditions:

- a) temperature: (25 ± 10) °C;
- b) atmospheric pressure: 86 kPa to 106 kPa (86 kPa); and
- c) relative humidity: 10 percent to 90 percent (without condensation).

102.2.1.2 *Test power requirements*

Power to the tested device shall be according to IS 12360, if designed to be supplied by utility supply network:

- a) a.c. power frequency: $50 \text{ Hz} \pm 0.5 \text{ Hz}$;
- b) a.c. power voltage: $240/415 \text{ V} \pm 10 \text{ percent}$;
- c) d.c. component on a.c. power: the offset less than 2 percent of the peak value;
- d) degree of voltage unbalance on a.c. power: less than 5 percent; and
- e) a.c. power waveform: sinusoidal, with a distortion factor less than 8 percent.

102.2.2 *Measuring Instruments*

The characteristics of the measuring equipment shall be suitable to verify the specified values in the corresponding test items.

The equipment for measurement of voltage, current, temperature and time shall be according to IS/ISO/IEC 17025 and IEC Guide 115.

102.2.3 *Test Load*

An artificial load such as a resistive load, an electronic load and a voltage source (for example, battery) shall be used. An electronic load operating under constant resistance mode is not considered as a resistive load. The artificial load requires an additional vehicle control simulator to establish analogue interface and/or digital communication with the d.c. electric vehicle supply equipment.

Unless otherwise specified, a resistive load or an electronic load shall be used for the compliance tests. An example of the test load, represented by a simplified equivalent circuit diagram, is shown in [Fig. 17](#).

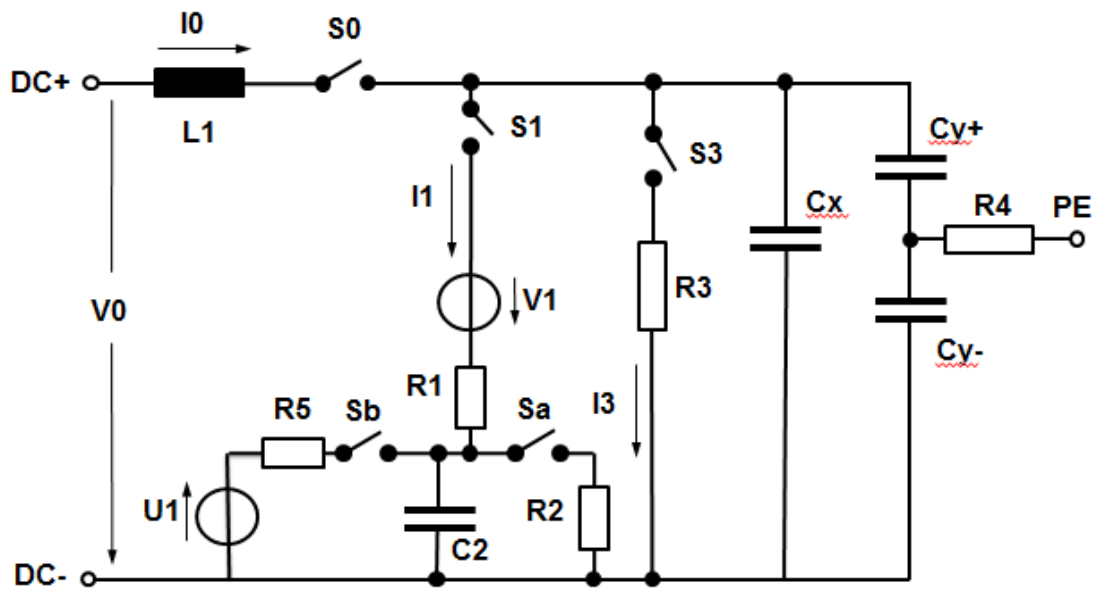

Key

Cx	X-capacitor (positive-negative)	I1	Emulated current to traction battery
Cy+	Y-capacitor (positive-earth)	I3	Emulated current to auxiliary load
Cy-	Y-capacitor (negative-earth)	L1	Inductor
C2	capacitor for emulating traction battery	R3	Resistor for emulating auxiliary load
I0	Output current of d.c. electric vehicle supply equipment	R5	Current-limiting resistor for U1
U1	Electronic load/controlled voltage source	PE	Protective conductor
V1	Ideal voltage source	S0, S1,	Contactor (switch)
V0	Output voltage of d.c. electric vehicle supply equipment	S3, Sa,	
		Sb	
R1, R2	Variable resistor to set operating voltage point		
R4	Resistor for emulating the voltage surge between positive-negative, positive-earth and negative-earth		

FIG. 17 EXAMPLE OF ARTIFICIAL LOAD

NOTE — The simplified equivalent circuit diagram of the charging circuitry in Fig. 17 is used for specifying the test conditions relevant to the test cases contained in this document, for example, present voltage and internal resistance of the electric vehicle battery. Only those electric properties of the electric vehicle charging circuitry are modelled that are relevant for checking conformity of an d.c. electric vehicle supply equipment with the requirements in this document. Properties of the charging circuitry of a real electric vehicle which are not relevant for checking conformity are not modelled by this diagram. It is important to note that this diagram does not mandate how a real test bench implements the electrical properties of the electric vehicle charging circuitry that are relevant for a specific test case. It is rather recommended to use a battery simulator to implement these properties, but it needs to be ensured that the test conditions given in the test case specifications are obeyed.

Recommended circuit parameters of the test load for each system are shown in Table 11.

Table 11 Recommended Circuit Parameters of the Test Load(Clause [102.2.3](#))

SI No.	Symbol	System C
(1)	(2)	(3)
i)	L1	0 H
ii)	Cx	470 μ F
iii)	Cy+/-	2 μ F
iv)	C2	5600 μ F
v)	S0	As specified in respective test
vi)	S1	As specified in respective test
vii)	S3	As specified in respective test
viii)	Sa	Closed
ix)	Sb	Open
x)	R1	Variable 50 m Ω to 100 m Ω
xi)	R2	Variable 0.1 m Ω to 2 m Ω
xii)	R3	10 Ω (up to 500 V) 50 Ω (500 V to 1 000 V)
xiii)	R4	50 Ω
xiv)	R5	Not used
xv)	U1	Not used
xvi)	V1	0 V to 1 000 V

102.2.4 Testing Point**102.2.4.1 Definition**

[Fig. 18](#) shows the range of operating voltage and current which can be output obtained by the d.c. electric vehicle supply equipment, and some specific operating points OP1, OP2, OP3, OP4,

OP5 and OP6 used as testing points in [101.2.1](#).

If the d.c. electric vehicle supply equipment shows any discontinuous behaviour in its operating range, for example, in case of cascaded architecture of power modules, it might be necessary to add additional testing points OPn.

ANNEX A

(Clauses 1, 6.3.1.116, 7.1.101, C-4.1 and D-1.2)

d.c. EV SUPPLY EQUIPMENT OF SYSTEM C OF DUAL GUN

A-1 GENERAL

This annex provides specific requirements for d.c. electric vehicle supply equipments for use with System C (hereinafter, also referred to as ‘d.c. charger’). System C is a Mode 4 charging system. The maximum system output voltage shall be limited to 1 000 V d.c. or less dependent on the components of the system.

A-2 COMMUNICATION

The general definitions and functions of the proximity pilot (PP) and control pilot (CP) — signals/contacts are according to IS 17017 (Part 1) : 2018 (including detailed resistor definitions in Table 12 and Table 13) with the specific resistor value for configuration FF given in Table 13. A CP duty cycle of 5 percent shall be used for each charging gun according to Annex A of IS 17017 (Part 1) : 2018.

Charge control communications between the d.c. electric vehicle supply equipment and the electric

vehicle shall comply with IS 17017(Part 24).

The physical layer for charge control communications shall comply with IS/ISO 15118-3.

Contact assignments of the different connectors are specified in IS 17017 (Part 2/Sec 3) : 2020.

Charge control communications shall comply with DIN SPEC 70121. Charge control communications shall also comply with IS/ISO 15118-2.

For automatic connection systems, the proximity pilot function is not required and communication can be carried out on a wireless physical layer according to IS/ISO 15118-6, IS/ISO 15118-7 and IS/ISO 15118-8.

The interface circuit of Fig. 19 shall be used for configuration FF.

The switch S_{pp} is optional for the electric vehicle to implement depending on its strategy to detect PE loss (see A-4)

Table 12 d.c. Couplers for Combined Charging System

(Clauses 12.103.3.1, A-2 and A-4)

SI No. (1)	d.c. Couplers for Combined Charging System (2)
i)	Configuration FF according to IS 17017 (Part 2/Sec 3) : 2020
ii)	Autoconnect charging device

Table 13 Definition of Proximity Resistor for Configuration FF

(Clause A-2)

SI No. (1)	Proximity Resistor [R _c as per IS 17017 (Part 1) : 2018] (2)	Maximum Current for a.c. Charging (3)	d.c. Connector for a.c. Charging (4)
i)	1 500 V	Not applicable	Configuration FF

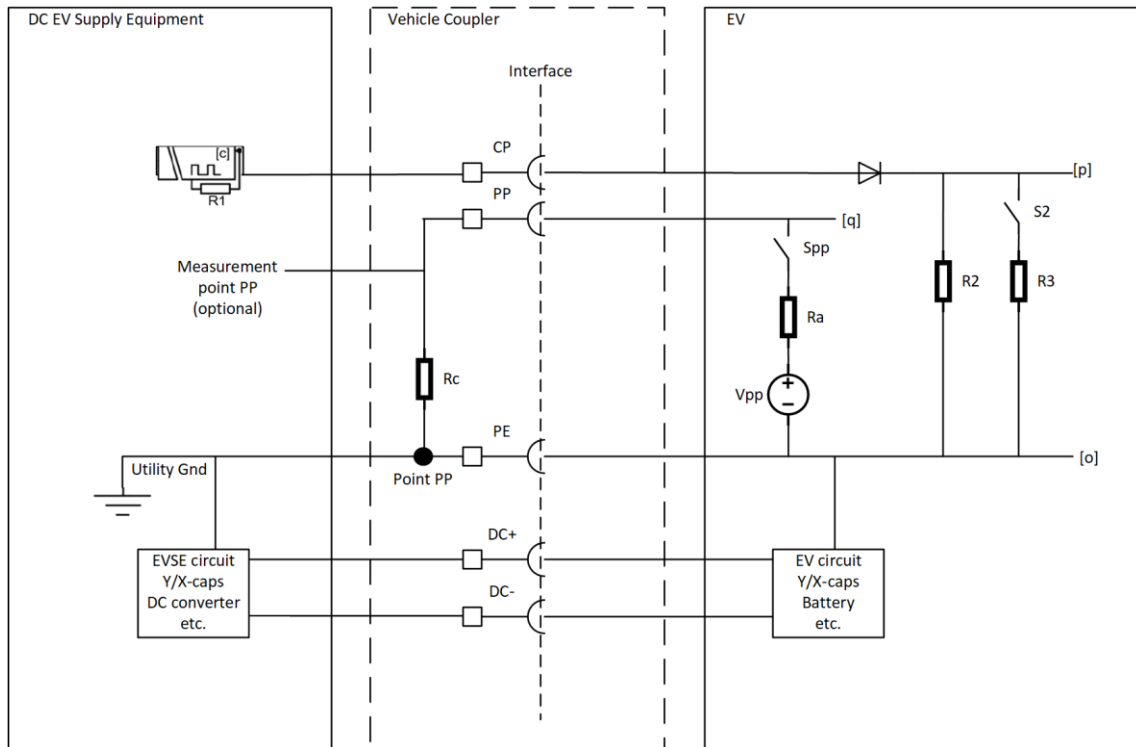

FIG. 19 INTERFACE COMPONENTS FOR CONFIGURATION FF

A-3 PROCESS OF ENERGY SUPPLY

A-3.1 General

The process of supplying energy to the electric vehicle by the d.c. electric vehicle supply equipment is initiated and controlled by the messages sent over HLC and shall follow the sequences shown in [Fig. 21](#), [Fig. 22](#), [Fig. 23](#), and [Fig. 24](#). For normal start up, normal shutdown, d.c. electric vehicle

supply equipment and electric vehicle initiated error shutdown, d.c. electric vehicle supply equipment initiated error or emergency shutdown and electric vehicle initiated error shutdown. electric vehicle initiated error shutdown shall also comply with the requirements of DIN SPEC 70121.

The messages described in DIN SPEC 70121 : 2014 and IS/ISO 15118-2 : 2014 are abbreviated in the sequence diagrams with numbers (see [Table 14](#)).

Table 14 Message Mapping for Sequence Diagram(Clause [A-3.1](#))

Phase	Message No.	DIN Spec 70121 : 2014 /IS/ISO 15118-2 : 2014
Data-link	SLAC	SLAC messages
Initialization	SDP	sdp messages
	0a	Supported app protocol req
	0b	Supported app protocol req
	1a - Xa	The electric vehicle messages requests concerning session setup, services, authentication, payment options and value added services (if supported by the negotiated application layer protocol).
	1b - Xb	The EVSE messages respond concerning session setup, services, authentication, payment options and value added services (if supported by the negotiated application layer protocol).
	3a	Charge parameter discovery req
	3b	Charge parameter discovery res
Insulation Check and Pre-Charge	4a	Cable check req
	4b	Cable check res
	5a	Pre charge req
	5b	Pre charge res
	6a	Power delivery req
	6b	Power delivery res
Energy Transfer	7a	Current demand req
	7b	Current demand res
	8a	Power delivery req
	8b	Power delivery res
Welded Check and Unlocking	9a	Welding detection req
	9b	Welding detection res
	10a	Sessions top req
	10b	Sessions top res

NOTE — The sequence diagram is applicable for both the charging the guns.

Example of charging sequence and description are shown in [Fig. 20](#) and [Table 18](#).

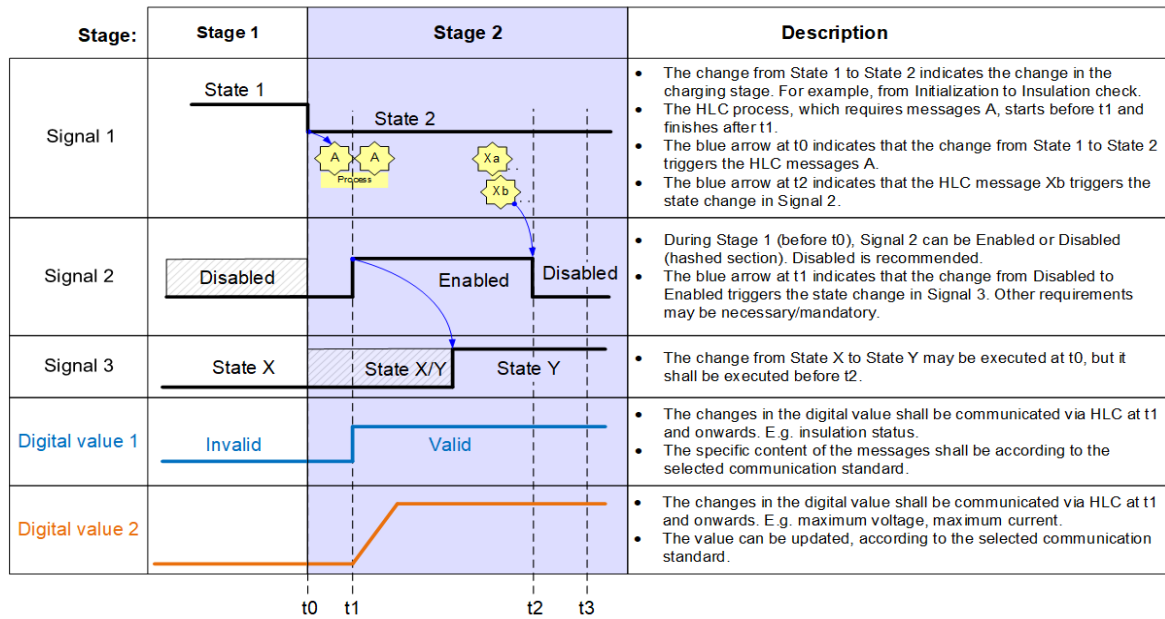

FIG. 20 EXAMPLE OF CHARGING SEQUENCE

Table 15 Example of Sequence Description

(Clause A-3.1)



Sl No.	Timestamp	Description: Explanation Charge Sequence
(1)	(2)	(3)
i)	► ta	• Events executed before reaching ta.
ii)	Ta	<ul style="list-style-type: none"> • Events that shall be executed at ta. • The events executed at this timestamp shall be completed before reaching the next timestamp.
iii)	ta ► tb	<ul style="list-style-type: none"> • Events that shall be executed between ta and tb. • The events inside a timeframe (between ta and tb) shall be executed in any order and completed before reaching the next timestamp if they do not have a time constraint (indicated with within). • If the event within a timeframe has a time constraint (within), then tb is the moment that this event is executed.
iv)	tb ►	• Events that shall be executed from tb onwards in any order

A-3.2 Normal Start Up

Sequence diagram and description for normal start up are shown in [Fig. 21](#) and [Table 16](#).

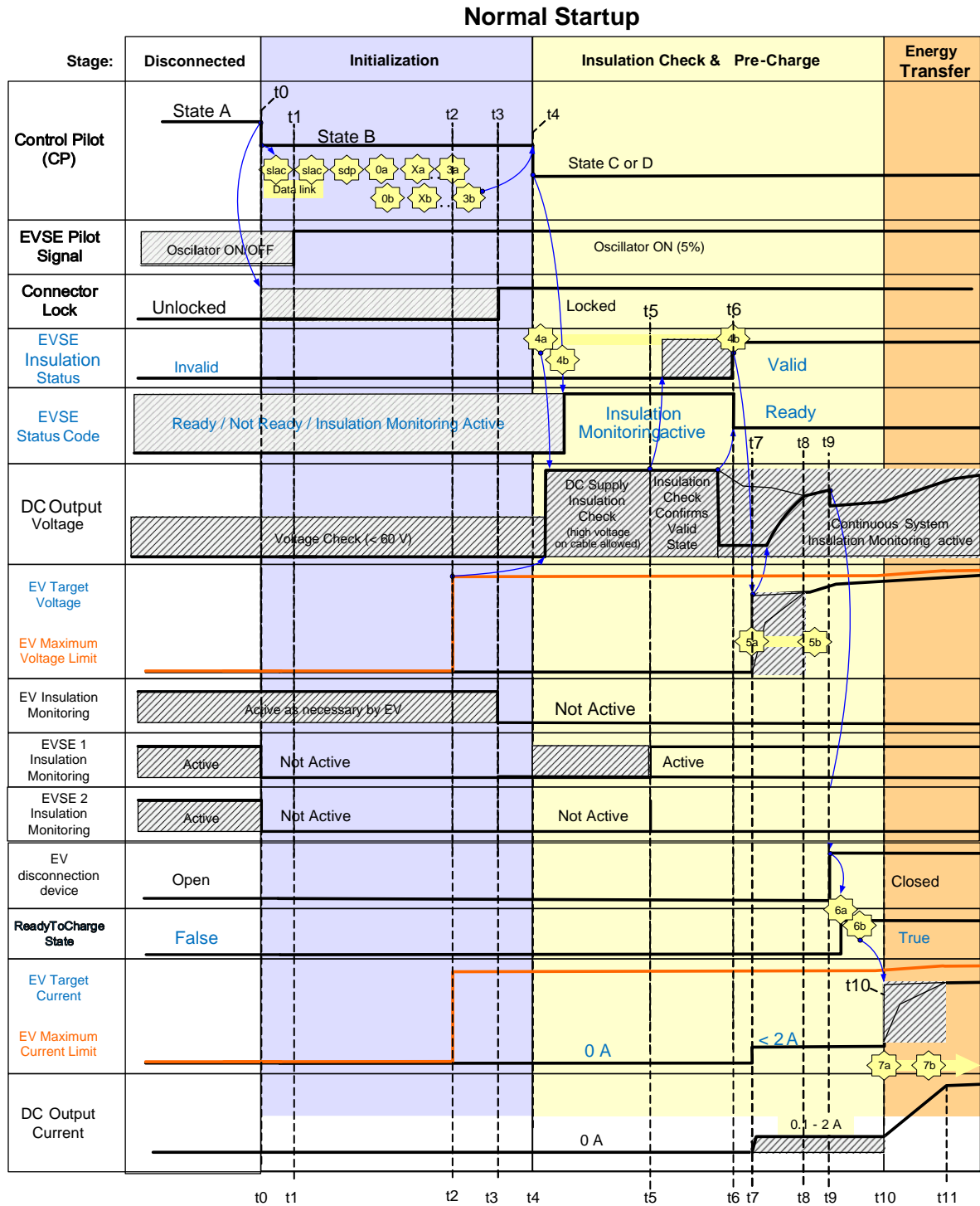

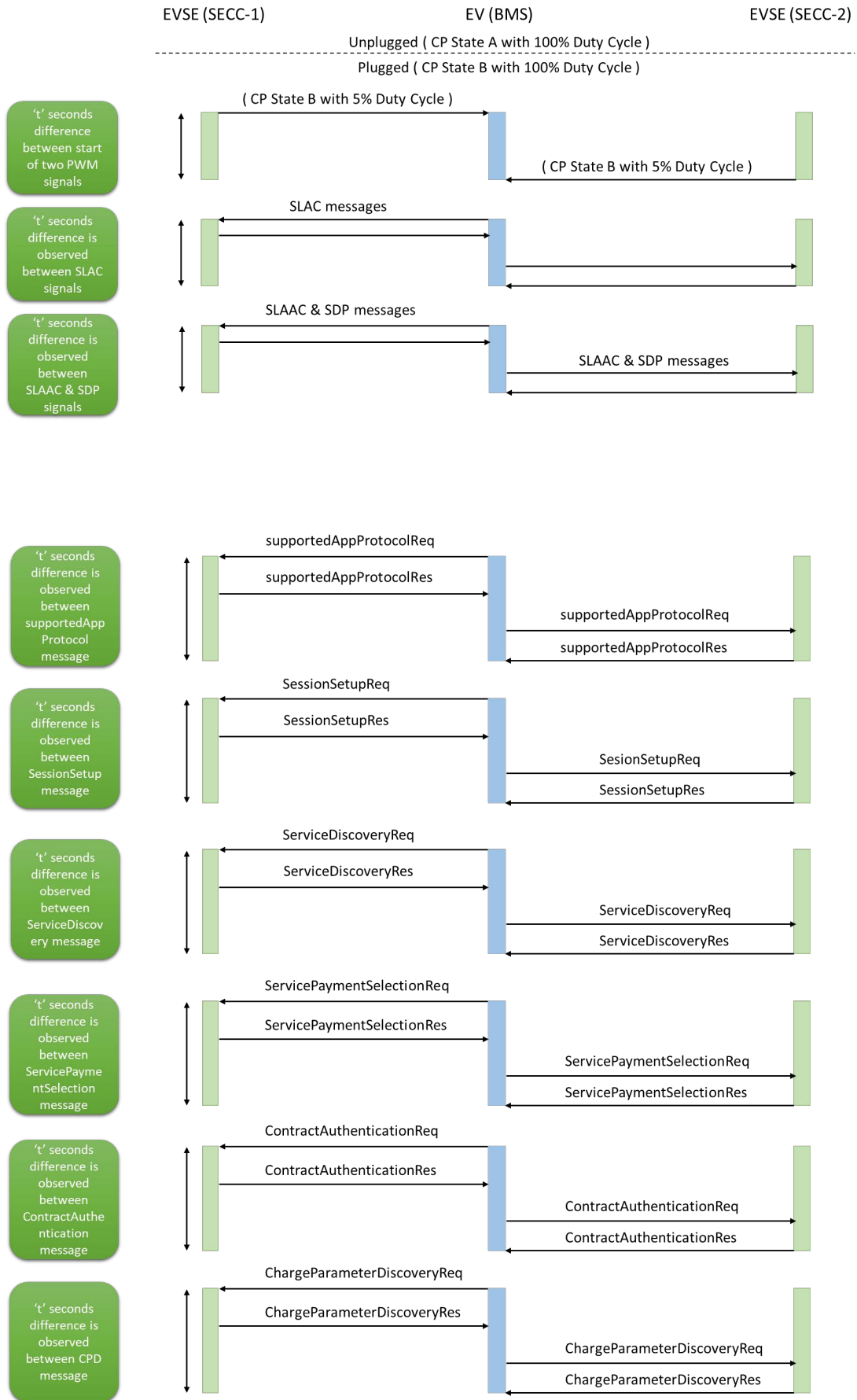



FIG. 21 SEQUENCE DIAGRAM FOR NORMAL START UP

Table 16 Sequence Description for Normal Start up (1 of 2)

(Clause [A-3.2](#))

Sl No.	Timestamp	Sequence Description for Normal Start Up
(1)	(2)	(3)
i)	► t0	<ul style="list-style-type: none"> The EVSE shall check if the d.c. output voltage is less than 60 V and shall not allow to start a supply session if 60 V is exceeded. <i>see</i> A-4.5.
ii)	t0	<ul style="list-style-type: none"> The vehicle connector is plugged into the electric vehicle inlet, which changes the CP state from A to B. After the CP state changed to B, the electric vehicle may lock the vehicle connector in its inlet. After the CP state changed to B, the EVSE insulation monitoring device shall stop. After the CP state changed to B, the electric vehicle may try to set up a data link as defined in IS 17017 (Part 24).
iii)	t1	<ul style="list-style-type: none"> The EVSE shall turn on its CP oscillator if the EVSE is ready to charge and if it not already turned on.
iv)	t1 ► t2	<ul style="list-style-type: none"> The electric vehicle shall establish the data link as defined in the IS 17017 (Part 24) after it has verified that the EVSE has turned on its CP oscillator. High level communication (V2G) starts by the negotiation of an appropriate application layer protocol between the electric vehicle <0a> and EVSE <0b>. The electric vehicle and EVSE exchange messages pairs concerning session setup, services, authentication, payment options and value added services (if supported by the negotiated application layer protocol).
v)	t2	<ul style="list-style-type: none"> The electric vehicle sends its electric vehicle maximum voltage limit and electric vehicle maximum current limit (amongst other parameters) for d.c. supply output current and voltage with chargeparameterdiscoveryreq <3a>.
vi)	t2 ► t3	<ul style="list-style-type: none"> The minimum and maximum values of the EVSE are sent to the electric vehicle with chargeparameterdiscoveryres <3b>. The EVSE shall check if the d.c. output voltage is less than 60 V and shall trigger an error shutdown if 60 V is exceeded. <i>See</i> A-4.5. The compatibility check is performed by the EVSE. The result (response code = 'OK' or 'FAILED_wrongchargeparameter') and status ('EVSE processing' = 'ongoing' or 'finished') shall be sent to the electric vehicle with charge parameter discovery res <3b>. After alignment of all parameters, the EVSE responds with parameter 'EVSE processing' = 'finished' in charge parameter discovery res <3b>.
vii)	t3	<ul style="list-style-type: none"> If the electric vehicle and EVSE are not compatible, then the electric vehicle shall not go to ready and will transfer to step t107 in the normal shutdown sequence. The electric vehicle shall lock the vehicle connector in its inlet before changing the CP to state C or D. The electric vehicle shall stop its insulation monitoring device, if any.
viii)	t4	<ul style="list-style-type: none"> After the electric vehicle has stopped its insulation monitoring device and after checking that the vehicle connector is locked, the electric vehicle changes the CP state from B to C/D by closing S2.
ix)	t4 ► t5	<ul style="list-style-type: none"> After checking that the vehicle connector is locked, the electric vehicle requests cable and insulation check before pre-charge with cable check req <4a>. <i>See</i> cable check A-4.1.3. The EVSE checks if the CP state changed to state C or D before sending the first cablecheckres <4b> message and before applying a voltage higher than 60V on the d.c. output.

Table 16 (Concluded)

SI No.	Timestamp	Sequence Description for Normal Start Up
(1)	(2)	(3)
		<ul style="list-style-type: none"> The EVSE checks the insulation of the d.c. output and continuously reports the insulation state with the parameter 'EVSE insulation status' in cable check res <4b>.
	t5	<ul style="list-style-type: none"> The EVSE determines that the insulation resistance of the d.c. output is $\geq 100 \text{ k}\Omega$.
x)	t5 ► t6	<ul style="list-style-type: none"> After having successfully finished the insulation check, the EVSE indicates with parameter 'EVSE insulation status' = 'valid' in subsequent messages, starting with cable check res <4b>.
xi)	t6	<ul style="list-style-type: none"> The EVSE shall send the result of the cable check by changing the parameters 'EVSE statuscode' to 'ready' and 'EVSEprocessing' to 'finished' in cable check res <4b>.
xii)	t6 ► t7	<ul style="list-style-type: none"> The EVSE may keep the voltage on the d.c. output.
xiii)	t7	<ul style="list-style-type: none"> Pre-charge starts when the electric vehicle sends prechargereq <5a>, which contains the requested d.c. current $\leq 2 \text{ A}$ (maximum inrush current according to A-6.2) and the requested d.c. voltage. See pre-charge (A-5.1). During pre-charge, the EVSE shall be able to supply a d.c. output current as defined in A-5.1, limit the output current to 2A (see A-6.2) and ignore the current request of the electric vehicle.

Table 16 (2 of 2)

(Clause [A-3.2](#))

Sl No.	Timestamp	Sequence Description for Normal Start Up
(1)	(2)	(3)
i)	t7 ► t8	• The EVSE adapts the d.c. output voltage to the requested value in <5a> and sends the corresponding pre charge res <5b>.
ii)	t8	• The d.c. output voltage reaches the voltage requested by the electric vehicle within the tolerances given in section 101.2.2 .
iii)	t8 ► t9	• The electric vehicle may adapt the requested d.c. output voltage with cyclic messages prechargereq <5a> (see Note in A-5.1). NOTE — To obtain an inlet voltage within the +/- 20 V of the battery voltage, the electric vehicle can adjust the pre-charge voltage request to compensate for tolerances and steady state errors.
iv)	t9	• The electric vehicle shall close its disconnection device only after verifying that the absolute voltage difference between the electric vehicle inlet and the electric vehicle battery is less than 20 V. See 9.2 in ISO 17409). NOTE — The electric vehicle should be protected against the case that the polarity of the d.c. output is reversed.
v)	t9 ► t10	• The electric vehicle sends powerdeliveryreq <6a> with ‘ready to charge state’ = ‘true’ to enable the EVSE output. • After disabling the pre-charge circuit, if any, and switching ON its power supply output, the EVSE communicates that it is ready for energy transfer with powerdeliveryres <6b>.
vi)	t10	• During charging, the EVSE continuously monitors the insulation of the d.c. output (see A-4.1.4). • The electric vehicle sets the electric vehicle target current with current demand req <7a> to start the energy transfer phase.
vii)	t10 ► t11	• The EVSE adapts its d.c. output current and voltage to the requested values in current demand req <7a>. • The EVSE reports the following information to the electric vehicle with Current Demand Res <7b>: - Its present d.c. output current and voltage, - Its present limits for d.c. output current and voltage, and - Its present status. NOTE — Electric vehicle may change its d.c. current and voltage request even if the d.c. output current has not reached the values in the previous request.
viii)	t11	• The d.c. output current reaches the d.c. output current request within the time delay (Td) defined in 101.2.3 .
ix)	t11 ►	• The electric vehicle adapts its d.c. current and voltage request according to its charging strategy with cyclic current demand req <7a> messages.

NOTE — It may be noted that the above sequence shall be followed by both the charging guns. There shall be a time difference of ‘t’ s between SECC1 and SECC2 as specified by OEMs.

A-3.3 Normal Shutdown

Sequence diagram and description for normal shutdown are shown in [Fig. 22](#) and [Table 17](#).

After the completion of normal shutdown, the electric vehicle shall not induce voltages above the values specified in [6.3.1.115](#).

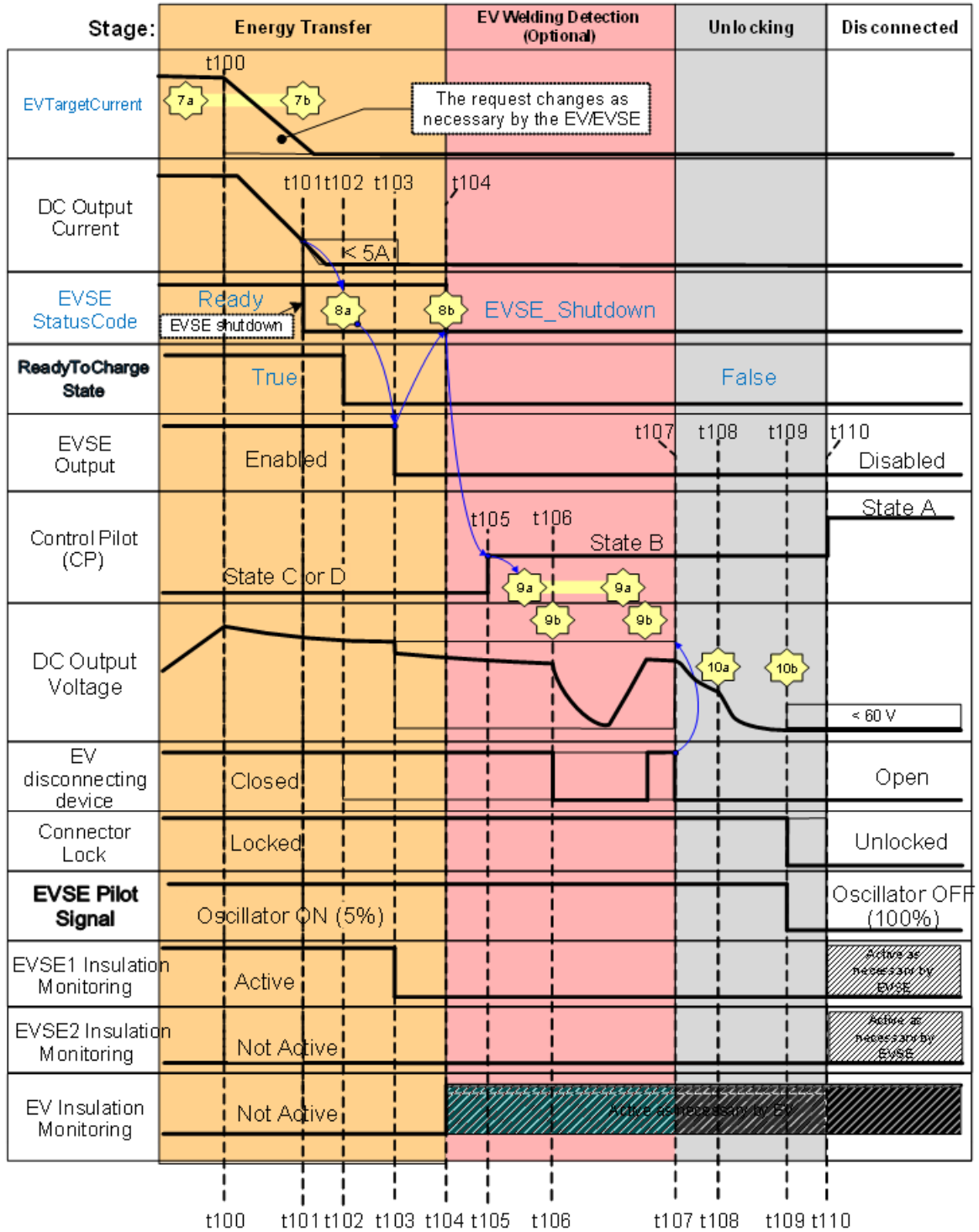

FIG. 22 SEQUENCE DIAGRAM AND DESCRIPTION FOR NORMAL SHUTDOWN BY EV/EVSE

Table 17 Sequence Description for Normal Shutdown (1 of 2)

(Clause [A-3.3](#))

SI No.	Timestamp	Sequence Description for Normal Shutdown by EV/EVSE
(1)	(2)	(3)
i)	► t100	Cyclic current demand messages between the electric vehicle <7a> and EVSE <7b>.
ii)	t100	If the electric vehicle wants to stop a charge session for a non-critical reason, it shall reduce the current request <7a> to terminate the energy transfer. Reduction is done on electric vehicle charging strategy.
		If the EVSE wants to stop a charge session for a non-critical reason, it shall: <ul style="list-style-type: none"> • ramp down the output current, and • adjust its maximum output current (EVSE <i>Max</i> current limit), which is communicated to the electric vehicle, according to this, in order to inform the electric vehicle that the d.c. output current will reduce.
		NOTES 1 This informs the electric vehicle that the d.c. output current is being reduced. 2 Legacy vehicles might directly go to t101 without reducing the current request. This will be interpreted as an electric vehicle-initiated error shutdown by the EVSE (<i>see</i> 'EV error shutdown table').
iii)	t100 ► t101	The d.c. output current shall decrease to less than 5 A and remain below 5 A.
iv)	t101	When the d.c. output current is below 5 A, the next Current Demand Res <7b> message, shall set the parameter EVSE statuscode to 'EVSE_shutdown' if the EVSE wants to stop the charge session.
v)	t102	The electric vehicle requests the EVSE to disable its output by sending message powerdeliveryreq <8a> with readytochargestate set to False.
vi)	t102 ► t104	The electric vehicle may open its disconnection device after the d.c. output current is below 5A and after the message <8a> has been sent.
vii)	t103	The EVSE shall disable its output and open its disconnection device, if any.
		The EVSE insulation monitoring device shall be disabled.
		The EVSE shall start to actively discharge any internal capacitance on its output.
		The EVSE shall not discharge the electric vehicle with more than 0.15 A (<i>see</i> A-5.5  A mode').
viii)	t104	The EVSE reports 'EVSE status code' = 'EVSE_shutdown' with message <8b>, to indicate it has disabled its output.
		The electric vehicle may activate its insulation monitoring device, if any.
		NOTE — The common mode and differential mode influences from the EVSE should be removed before sending the message <8b>.
ix)	t105	The electric vehicle changes CP state to B after receiving message <8b>.
		NOTE — If the electric vehicle decides not to perform welding detection, it proceeds with t107.
x)	t105 ► t106	The electric vehicle sends initial welding detection request <9a>.
xi)	t106	The electric vehicle may perform its welding detection check after receiving message weldingdetectionres <9b>.
		Electric vehicle may actuate its disconnection device to perform welding detection.
xii)	t106 ► t107	The electric vehicle may send multiple <9a> requests in order to read the d.c. supply output voltage measured by the EVSE in the response message <9b>.

Table 17 (Concluded)

SI No.	Timestamp	Sequence Description for Normal Shutdown by EV/EVSE
(1)	(2)	(3)
xiii)	t107	The electric vehicle completes welding detection, if performed.
		The electric vehicle shall open its disconnection device.
		NOTE — This starts the reduction of the d.c. output voltage by passive discharge.
xiv)	t108	The electric vehicle shall send the sessions top req <10a> message when it has confirmed that its disconnection device is open.
		The sessions top req <10a> message initiates termination of HLC through PLC.
		The EVSE shall start to reduce the d.c. output voltage to less than 60 V within 1s and remain below 60 V.
xv)	t108 ► t109	The EVSE shall send the message sessionstopres <10b>.
xvi)	t109	The EVSE shall turn off its CP oscillator according to IS 17017 (Part 24).

Table 17 (2 of 2)

(Clause [A-3.3](#))

SI No.	Timestamp	Sequence Description for Normal Shutdown by EV/EVSE
(1)	(2)	(3)
i)	t109 ► t110	<p>The electric vehicle shall only unlock the connector if the d.c. output voltage is below 60 V.</p> <p>The electric vehicle should wait to receive message sessionstopres <10b> before unlocking.</p> <p>NOTES</p> <p>1 If digital communication according to IS/ISO 15118 is used, the EV may request a pause according to IS/ISO 15118-2 : 2018. If supported by the EVSE, the EV can wake up the EVSE and re-initiate a charging session (see A-5.2). The communication session will re-start after the wake up process.</p> <p>2 If the EVSE is ready for re-initiation of a new charging session, use the sequence described in A-5.2.</p>
ii)	t110	Disconnecting of vehicle connector changes CP state from B to A.

NOTE — It may be noted that the above sequence shall be followed by both the charging guns. There shall be a time difference of “t” sec between SECC1 and SECC2 as specified by OEMs.

A-3.4 Error and Emergency Handling

d.c. electric vehicle supply equipment and electric vehicle shall have means to initiate error or emergency shutdowns.

NOTE — Error shutdown is to prevent damage to the equipment. While emergency shutdown is to protect the user from a hazardous situation.

During an error or emergency shutdown, the electric vehicle shall open its disconnection device within 100 ms after the EVSE has turned off its CP oscillator or the electric vehicle has triggered the emergency shutdown.

[Table 18](#) gives an overview of the error and emergency shutdown cases defined in this document.

Table 18 Overview of Error and Emergency Shutdown Cases

(Clause [A-3.1](#) and [A-3.4](#))

SI No.	Cases for error shutdown	Cases for emergency shutdown
(1)	(2)	(3)
i)	Message sequence error	CP loss reaction (A-4.3)
ii)	Cable check errors (A-4.1.3)	Overcurrent protection (A-6.5)
iii)	Insulation monitoring during charging (A-4.1.4)	Continuous continuity checking of the protective conductor (6.3.1.2)
iv)	Protection against overvoltage between positive terminal d.c. + and negative terminal d.c. - at the interface (6.3.1.106)	Control circuit supply integrity (6.3.1.108)
v)	Load dump (101.2.7)	Maximum voltage between d.c. +/- and protective conductor in conditions with a single earth fault (6.3.1.113)
vi)	Over temperature handling (101.4.2.2)	Short-circuit protection (13.101)
vii)	Check of the plausibility of the values provided by the thermal sensing (101.4.2.3)	If error shutdown doesn't work properly

A-3.5 d.c. EV Supply Equipment and EV Initiated Error Shutdown

Sequence diagrams and descriptions for d.c. electric vehicle supply equipment and electric vehicle initiated error shutdown are shown in [Fig. 23](#) and [Table 19](#).

During an error shutdown, both the charging guns of electric vehicle could enter the welding detection phase simultaneously and perform a welding detection if the HLC support this and is available (see [A-4](#)).

After the completion of an error shutdown, both the charging guns of electric vehicle shall not induce

voltages above the values specified in [6.3.1.116](#).

A-3.6 d.c. EV Supply Equipment and EV Initiated Emergency Shutdown

Sequence diagrams and descriptions for d.c. electric vehicle supply equipment and electric vehicle initiated emergency shutdown are shown in [Fig. 24](#) and [Table 20](#).

After the completion of an emergency shutdown, the electric vehicle shall not induce voltages above the values specified in [6.3.1.117](#).

NOTE — The electric vehicle cannot enter the welding detection phase nor can it perform a welding detection based on voltages above the values specified in [6.3.1.117](#).

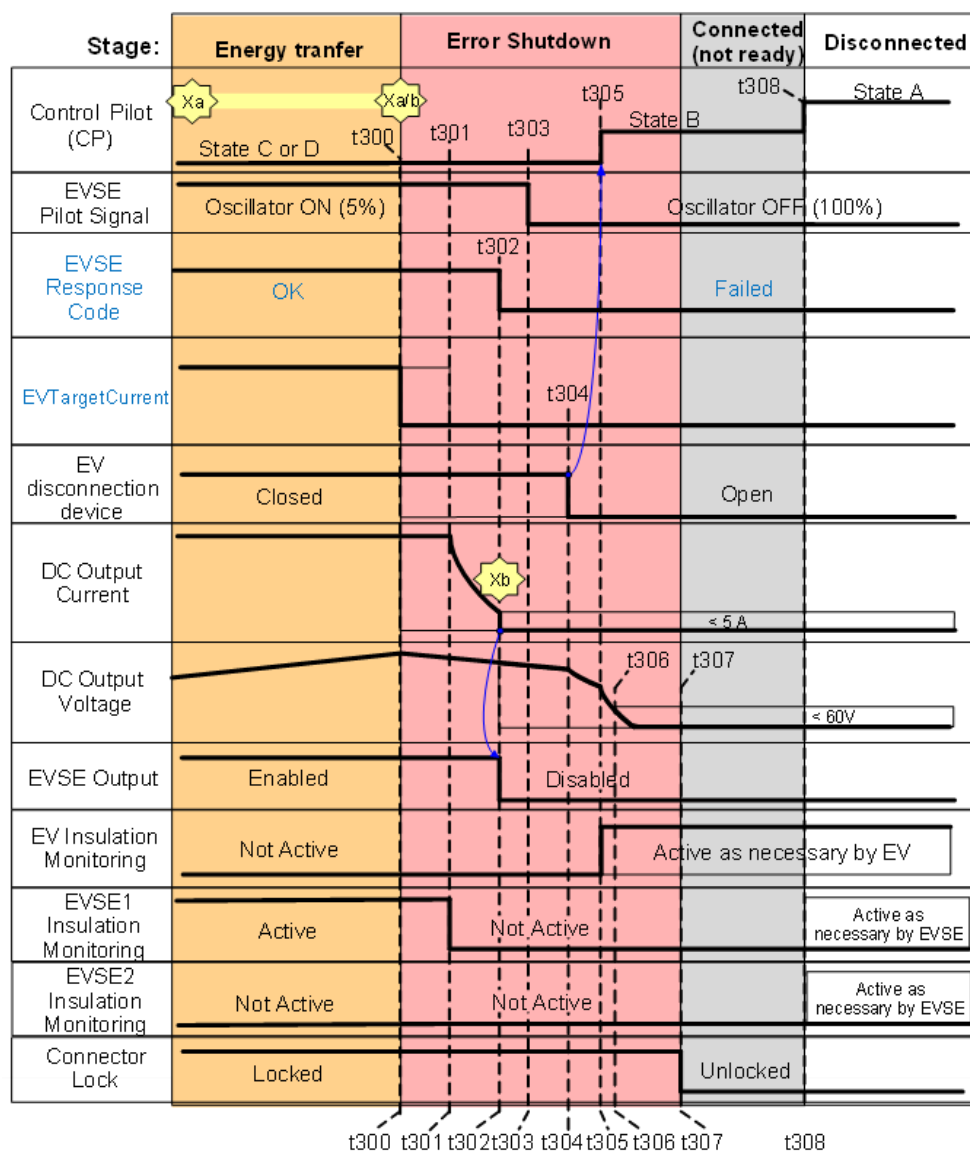

FIG. 23 SEQUENCE DIAGRAM FOR d.c. EV SUPPLY EQUIPMENT AND EV INITIATED ERROR SHUTDOWN

Table 19 Sequence Description for d.c. EV Supply Equipment and EV Initiated Error Shutdown(Clause [A-3.5](#))

SI No.	Timestamp	Sequence Description for Error Shutdown for any stage by EVSE or by EV (Excluding Table 46)
(1)	(2)	(3)
i)	▶ t300	<ul style="list-style-type: none"> • General pre-condition: High level communication messages between the electric vehicle <Xa> and EVSE <Xb>. • Preconditions for electric vehicle initiated error shutdown: CP state B, C or D. • Preconditions for EVSE initiated error shutdown: CP Oscillator ON.
ii)	t300	<ul style="list-style-type: none"> • Occurrence of error shutdown condition detected by the electric vehicle or EVSE (for example, the electric vehicle triggers an error shutdown via HLC, communication loss or closing of the data link or TCP connection). • The trigger time starts from this moment. • The electric vehicle may open its disconnection device (for the electric vehicle-initiated error shutdown). <p>NOTES</p> <p>1 Error shutdown is to prevent damage to the equipment. 2 The trigger time for electric vehicle initiated error shutdown depends on communication requirements.</p>
iii)	t301	<ul style="list-style-type: none"> • The EVSE performs the error shutdown. • The timing requirements of 6.3.1.116 (performance time) starts from this moment. • The EVSE shall disable its insulation monitoring device.
iv)	t301 ▶ t302	<ul style="list-style-type: none"> • The EVSE shall reduce its d.c. output current to less than 5A and disable its output within 1s.
v)	t301 ▶ t306	<ul style="list-style-type: none"> • The EVSE shall, within 2.5 s: <ul style="list-style-type: none"> - reduce the d.c. output voltage to less than 60 V between d.c.+ and d.c.-; and - reduce the d.c. output voltage to less than 28 V between d.c.+ and earthing terminal, and between d.c.- and earthing terminal.
vi)	t302	<ul style="list-style-type: none"> • The d.c. output current shall be less than 5A and remain at less than 5A. • The EVSE shall disable its output. • EVSE initiated error shutdown: <ul style="list-style-type: none"> - The EVSE shall send responsecode 'failed' in the next response messages [<i>see</i> IS 17017 (Part 24)]. • Electric vehicle initiated error shutdown if the HLC is still operational (<i>see</i> IS/ISO 15118-2 for the exception case): <ul style="list-style-type: none"> - The EVSE shall reply with message sessions to pres <10b> (<i>see</i> DIN 70121).
vii)	t302 ▶ t303	<ul style="list-style-type: none"> • The EVSE shall turn off its CP oscillator within 200 ms.
viii)	t303	<ul style="list-style-type: none"> • The EVSE is turning off its CP oscillator. <p>NOTES</p> <p>1 Turning off the CP oscillator without sending a message <Xb> containing a 'failed' responsecode will trigger an emergency shutdown (<i>see</i> 6.3.1.117). The delay of 200ms should be sufficient for the electric vehicle to receive this message.</p> <p>2 If the EVSE has not turned OFF its CP oscillator 1 s after the error shutdown has started (t300), the electric vehicle and EVSE shall trigger an emergency shutdown. <i>See</i> 6.3.1.117 for</p>

Table 19 (Concluded)

SI No.	Timestamp	Sequence Description for Error Shutdown for any stage by EVSE or by EV (Excluding Table 46)
(1)	(2)	(3)
		the timing requirements for the EVSE regarding d.c. output current, disconnection device and oscillator.
ix)	t303 ► t304	<ul style="list-style-type: none"> • The electric vehicle shall open its disconnection device within 100 ms after the EVSE has turned off its CP oscillator.
x)	t304	<ul style="list-style-type: none"> • The electric vehicle is opening its disconnection device.
xi)	t305	<ul style="list-style-type: none"> • The electric vehicle shall change the CP state to B when it has opened its disconnection device. • The electric vehicle may activate its insulation monitoring device.
xii)	t306	<ul style="list-style-type: none"> • The d.c. output voltage shall be: <ul style="list-style-type: none"> - less than 60 V between d.c.+ and d.c.- ; and - less than 28 V between d.c.+ and PE, and between d.c.- and PE. <p>NOTE — The d.c. output voltages shall be at these values 2.5 s after the error shutdown was triggered at t300. See 6.3.1.116 for the timing requirements for the EVSE regarding d.c. output voltage.</p>
xiii)	t307	<ul style="list-style-type: none"> • The electric vehicle shall not unlock the connector unless the d.c. output voltage has dropped below 60 V (see 6.3.1.103).
xiv)	t308	<ul style="list-style-type: none"> • Disconnecting of vehicle connector changes CP state from B to A.

NOTE — It may be noted that the above sequence shall be followed by both the charging guns. There shall be a time difference of 't' s between SECC1 and SECC2 as specified by OEMs.

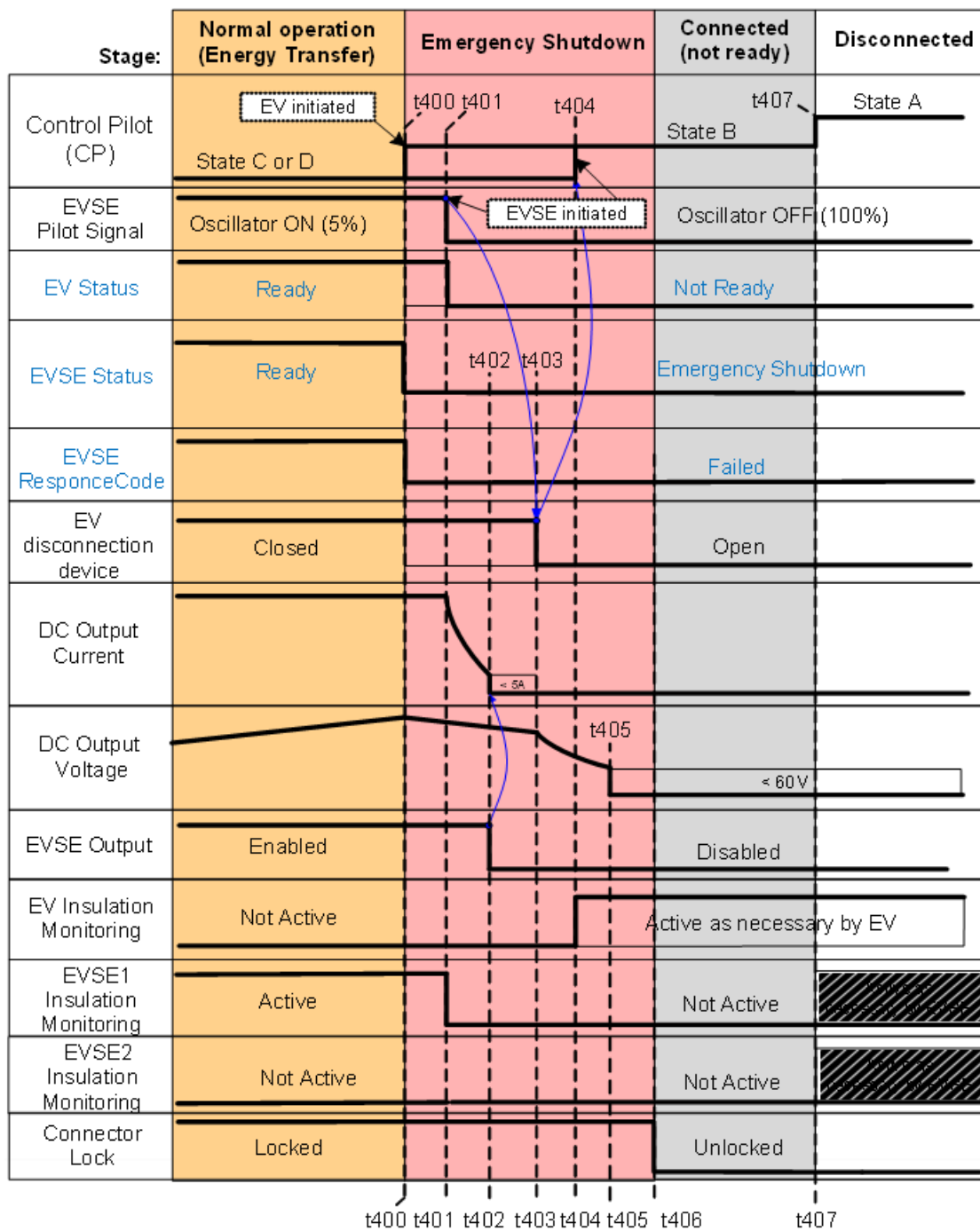



FIG. 24 SEQUENCE DIAGRAM FOR d.c. EV SUPPLY EQUIPMENT AND EV INITIATED EMERGENCY SHUTDOWN

Table 20 Sequence Description for d.c. EV Supply Equipment and EV Initiated Emergency Shutdown(Clause A-3.5) 

SI No.	Time Stamp	Sequence Description for Emergency Shutdown by EV or EVSE
(1)	(2)	(3)
i)	▶ t400	<ul style="list-style-type: none"> • General pre-condition: High level communication messages between the electric vehicle <Xa> and EVSE <Xb>. • Pre-condition for EVSE-initiated emergency shutdown: CP oscillator on. • Pre-condition for electric vehicle-initiated emergency shutdown: CP state C/D.
ii)	t400	<ul style="list-style-type: none"> • Occurrence of emergency shutdown condition (for example, the CP state changes from C/D to state B or A/E/F/invalid, PE loss). <p>NOTES</p> <p>1 Emergency shutdown is to protect the user from a hazardous situation. 2 Emergency shutdown initiated by the electric vehicle is performed by changing CP state from C/D to B.</p> <ul style="list-style-type: none"> • The trigger time starts from this moment. • The electric vehicle may open its disconnection device (for the electric vehicle-initiated emergency shutdown).
iii)	t400 ▶ t401	<ul style="list-style-type: none"> • The EVSE shall turn off its CP oscillator within the trigger time.
iv)	t401	<ul style="list-style-type: none"> • The EVSE is turning off its CP oscillator which indicates an emergency shutdown. <p>NOTE — The timing requirements of 6.3.1.117 (performance time) start from this moment.</p> <ul style="list-style-type: none"> • The EVSE shall disable its insulation monitoring device.
v)	t401 ▶ t402	<ul style="list-style-type: none"> • The EVSE shall reduce its d.c. output current to less than 5 A and disable its output within 30 ms.
vi)	t401 ▶ t403	<ul style="list-style-type: none"> • The electric vehicle shall open its disconnection device within 100 ms after the CP oscillator is turned off or if it detected an ‘occurrence of the emergency shutdown condition’.
vii)	t401 ▶ t404	<ul style="list-style-type: none"> • The electric vehicle shall go to CP state B within 100 ms after the CP oscillator is turned off or if it detected an ‘occurrence of the emergency shutdown condition’.
viii)	t401 ▶ t405	<ul style="list-style-type: none"> • The EVSE shall, within 1 s: <ul style="list-style-type: none"> - reduce the d.c. output voltage to less than 60 V between d.c. + and d.c. -; and - reduce the d.c. output voltage to less than 28 V between d.c.+ and earthing terminal, and between d.c. - and earthing terminal.
ix)	t401 ▶	<ul style="list-style-type: none"> • Both the electric vehicle and EVSE may try to keep communicating if possible. • If the electric vehicle or EVSE send a message, then it shall send a ‘failed’ response code.
x)	t402	<ul style="list-style-type: none"> • The EVSE has reduced its d.c. output current to less than 5 A. • The EVSE shall disable its output.
xi)	t403	<ul style="list-style-type: none"> • Latest point in time the electric vehicle disconnection device is opened.
xii)	t404	<ul style="list-style-type: none"> • For EVSE-initiated emergency shutdown: The electric vehicle shall change the CP state to B to indicate that the electric vehicle opened its disconnection device.

Table 20 (Concluded)

SI No.	Time Stamp	Sequence Description for Emergency Shutdown by EV or EVSE
(1)	(2)	(3)
		• The electric vehicle may activate its insulation monitoring device, if any.
xiii)	t405	• The d.c. output voltage shall be: - less than 60V between d.c. + and d.c. - ; and - less than 28V between d.c.+ and PE, and between d.c. - and PE.
xiv)	t406	• The electric vehicle shall not unlock the connector unless the d.c. output voltage has dropped below 60 V.
xv)	t407	• Disconnecting of vehicle connector changes CP state from B to A.

A-4 SAFETY MEASURES

A-4.1 IT (Isolated Terra) System Requirements

A-4.1.1 General

The secondary circuit (output side) of the d.c. electric vehicle supply equipment shall be designed as an IT system and protection measures in accordance with 411 of IEC 60364-4-41 : 2005 shall be applied.

An insulation monitoring device (IMD) according to IEC 61557-8 or equivalent shall be used to perform insulation monitoring between d.c. + and PE as well as d.c. – and PE during supply process and communicate the current state (valid, fault) of the system periodically to the electric vehicle.

The d.c. electric vehicle supply equipment shall react according to [Table 21](#).

Table 21 Insulation States and d.c. EV Supply Equipment Reaction Based on the Measured Insulation Resistance
(Clause [A-4.1.1](#))

SI No.	Condition 1	Condition 2	Insulation State	d.c. EV Supply Equipment Reaction
(1)	(2)	(3)	(4)	(5)
i)	Above 150 kΩ	Above 300 kΩ	Valid	Allow charging
ii)	From 100 kΩ to 150 kΩ	From 100 kΩ to 300 kΩ	Valid or fault	Allow charging or error shutdown
iii)	Below 100 kΩ	Below 100 kΩ	Fault	Error shutdown

Condition 1: External insulation resistance at the d.c. output either between d.c. + and PE or between d.c. - and PE (but not at the same time).

Condition 2: External insulation resistance at the d.c. output both between d.c. + and PE as well as between d.c. - and PE (at the same time).

A-4.1.2 Functional Test of Insulation Monitoring Device

The functionality of the insulation monitoring device (IMD) shall be tested during the functional test of the IMD, for example, by actuating a test device or by inserting a defined test resistor.

The functional test of the IMD shall detect if the IMD is connected to the d.c. output conductors (d.c. +/d.c. -) and protective earth (PE) and that the IMD is capable of measuring the insulation resistances between d.c. + and PE and d.c. - and PE.

The functional test of the IMD shall not deteriorate the IMD.

NOTE — During the functional test of the IMD, the requirements of [12.5](#) are applicable.

The functional test of the IMD shall be executed and finished during the cable check phase.

The functional status of the IMD can be as follows:

- a) Unknown: Functional test of the IMD has not been executed yet. In this state charging shall not be allowed;
- b) OK: After the functional test of the IMD has been passed the station shall go into the OK state; and
- c) Failed: The functional test of the IMD has failed. In this state, entering the pre-charge phase shall not be allowed.

NOTES

1 The purpose of this functional test of the IMD is to check whether the insulation monitoring device is capable of fulfilling its monitoring function on the d.c. output of the d.c. electric vehicle supply equipment and not to check if the insulation of the system is below a certain threshold. By checking the measurement connections of the IMD to the system conductors and to earth, the complete measurement circuit of the IMD can be tested.

2 During the activation of the functional test of the IMD, the response time of the insulation monitoring device can be extended as long this does not happen during the energy transfer stage.

Compliance is checked by design review.

A-4.1.3 Cable Check

Prior to each pre-charge phase, a cable check has to be performed. During the cable check, the d.c. electric vehicle supply equipment shall apply on the d.c. output the lower value of the following two voltages:

- a) 110 percent of the maximum voltage communicated by the electric vehicle to the EVSE during initialization phase; and
- b) Maximum output voltage of the d.c. electric vehicle supply equipment.

Requirements for protection against overvoltage at the interface according to [6.3.1.106](#) do not apply during cable check.

The d.c. electric vehicle supply equipment shall perform a short circuit detection according to [6.3.1.109](#) during the cable check phase.

During the cable check, the d.c. electric vehicle supply equipment shall limit the output current to a maximum of 5 A.

The d.c. electric vehicle supply equipment may perform a welding detection during the cable check phase. If the d.c. electric vehicle supply equipment performs a welding detection, then it shall still comply with the requirements of [6.3.1.112](#) and [6.3.1.113](#).

NOTE — The electric vehicle should take care not to be influenced by the common mode influences which the d.c. electric vehicle supply equipment can produce during its welding detection.

The functional test of the IMD (*see* [A-4.1.2](#)) shall be executed and finished during the cable check phase.

During cable check the insulation resistance shall be continuously monitored. The insulation states can be as follows:

- a) Invalid: The functional test of the IMD (*see* [A-4.1.2](#)) has not resulted in the OK state and/or the IMD has not finished the measurement of the insulation resistance. The d.c. electric vehicle supply equipment shall trigger an error shutdown if the IMD remains in invalid state until the end of the cable check phase;
- b) Valid: The measured insulation resistance between d.c. +/d.c. - and PE is above or equal to a value of 100 k Ω (without negative tolerance);
- c) Fault: The measured insulation resistance between d.c. +/d.c. - and PE is below a value of 100 k Ω (without negative tolerance). The d.c. electric vehicle supply equipment shall trigger an error shutdown before or at the end of the cable check phase and send a fault message to electric vehicle if necessary according to IS 17017 (Part 24); and
- d) In order to fulfil the timing requirements of the digital communication according to IS 17017 (Part 24), the EVSE shall be able to detect a valid state within V2G_SECC_cable_check_performance (= 38 s according to IS/ISO 15118).

Compliance is checked by [A-9.3.16.1](#). 

A-4.1.4 Insulation Monitoring During Charging

During charging, the insulation resistance of the system shall be continuously monitored. The insulation states can be as follows:

- a) Valid: The measured insulation resistance between d.c. +/d.c. – and PE is above or equal to a value of 100 k Ω (without negative tolerance); and
- b) Fault: The measured insulation resistance between d.c. +/d.c. – and PE is below a value of 100 k Ω (without negative tolerance). The d.c. electric vehicle supply equipment shall trigger an error shutdown within 10 s and send a fault message to electric vehicle if necessary according to IS 17017 (Part 24)

NOTES

1 The d.c. electric vehicle supply equipment can issue an optical and/or acoustical signal to the user.

2 The electric vehicle takes responsibility for the time coordination of its IMD. Prior to closing its electric vehicle disconnection devices (cf. time t_7 in Fig. 21) the electric vehicle either turns off its IMD or it is guaranteed that no interference with the station's IMD occurs.

Compliance is checked by **A-9.3.16.2** 

A-4.2 Combined Coupler Latching Function

For all types of d.c. connectors according to Table 12, the vehicle inlet shall provide a latching function to mitigate unintentional disconnecting of the vehicle connector from the vehicle inlet during energy supply.

Requirement for latching function is stated in ISO 17409.

A-4.3 CP Loss Reaction

When an unintended transition from CP state C/D to state B/A, any other or an unknown state occurs, the d.c. electric vehicle supply equipment and the

electric vehicle shall trigger an emergency shutdown within 10 ms.

A-4.4 Voltage Check at Initialization

At beginning of supply session, with CP state A or B, the d.c. electric vehicle supply equipment shall check if voltage on the cable is less than 60 V and shall terminate supply session if 60 V is exceeded.

A-4.5 d.c. EV Supply Equipment Maximum Output Y Capacitance

The maximum total parallel Y capacitance shall not exceed 1 μ F. This implies ≤ 500 nF Y capacitance across each d.c. rail and ground for a d.c. electric vehicle supply equipment with Y capacitance equally distributed between each d.c. rail and ground.

A-4.6 Minimum Cross-Sectional Area of Protective Conductor

The minimum cross-sectional area of the protective conductor for each charging gun shall be 6 mm².

A-4.7 Leakage and Charge Limitation of Touch Current

The d.c. electric vehicle supply equipment shall limit the steady-state leakage current and the charge to d.c. 2 according to IEC 60479-1 and C1 according to **8.102.4** of IEC 60479-2.

The following shall be considered to meet the requirements above:

- a) a human body impedance of 500 Ω ;
- b) the maximum Y-capacitances of the electric vehicle according ISO 17409; and
- c) a worst-case asymmetric leakage resistance of the electric vehicle where charging is still possible.

Compliance is verified using a calculation, for instance using the following example (*see* [Fig. 25](#), [Fig. 26](#) and [Table 27](#)) or an equivalent simulation or measurement.

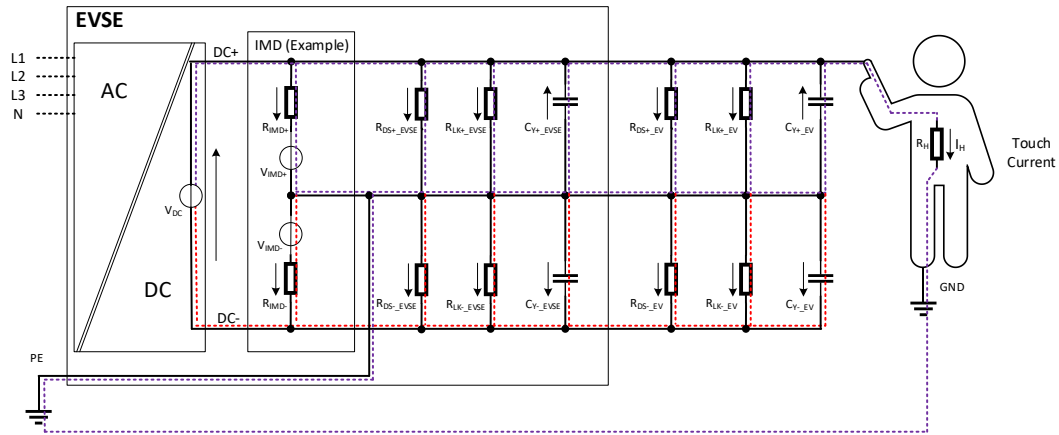

FIG. 25 CIRCUIT DIAGRAM WITH COMPONENTS INFLUENCING THE TOUCH CURRENT

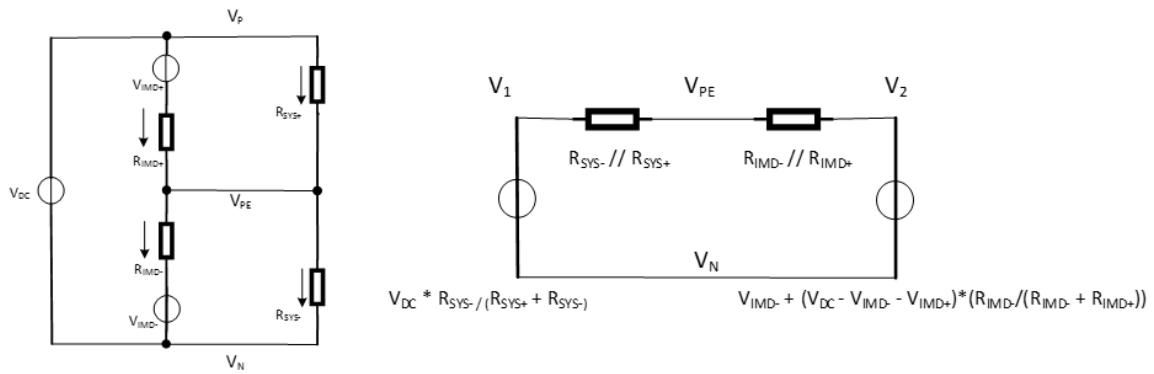



FIG. 26 EQUIVALENT CIRCUITS FOR EXAMPLE IN FIG. 25

Table 22 Exemplary Determination if Touch Current Limit is fulfilled by Design

(Clause  [A.7.6](#))

Vdc	Maximum Output voltage		920	V	
Vimd+	IMD measurement voltage		50	V	
Vimd-	IMD measurement voltage	= -Vimd+	-50	V	
Rimd+	IMD measurement resistance		120 000	Ω	
Rimd-	IMD measurement resistance		120 000	Ω	
Rds+_EVSE	Designed resistance EVSE +		1 000 000	Ω	
Rds-_EVSE	Designed resistance EVSE -		1 000 000	Ω	
Rlk+_EVSE	Leakage resistance EVSE +		1 000 000	Ω	
Rlk-_EVSE	Leakage resistance EVSE -		1 000 000	Ω	
Rds+_EV	Designed resistance EV +		1000 000	Ω	
Rds-_EV	Designed resistance EV -		1 000 000	Ω	
Rlk+_EV	Leakage resistance EV +		1 000 000	Ω	
Rlk-_EV	Leakage resistance EV -		100 000	Ω	
Rh	Human body representation		500	Ω	
Cy+EV	Y capacitance EV +		2.00E-06	F	
CY-EV	Y capacitance EV -		2.00E-06	F	
Cy+EVSE	Y capacitance EVSE +		5.00E-07	F	
CY-EVSE	Y capacitance EVSE -		5.00E-07	F	
Ctot	Total Y capacitance system	=Cy+EV+CY-EV+Cy+EVSE+CY-EVSE	5.00E-06	F	
Rsys+	System resistance +	=1/(1/Rds+_EVSE)+(1/Rlk+_EVSE)+(1/Rds+_EV)+(1/Rlk+_EV)+(1/Rh)	499	Ω	
Rsys-	System Resistance -	=1/((1/Rdc-_EVSE)+(1/Rlk-_EVSE)+(1/Rds-_EV)+(1/Rlk-_EV))	76 923	Ω	
Rsys+nh	Rsys+ without human	=1/((1/Rds+_EVSE)+(1/Rlk+_EVSE)+(1/Rds+_EV)+(1/Rlk+_EV))	250 000	Ω	
Rsys	Total system resistance	=1/((1/Rsys+)+(1/Rsys-))	495.785	Ω	
Rimd	Total IMD resistance	=1/((1/Rimd+)+(1/Rimd-))	60 000	Ω	
Rsys_nh	Rsys without human	=1/((1/Rsys+_nh)+(1/Rsys-))	58 823.5	Ω	

Table 22 (Concluded)

V1	Thevenin equiv. V1	$=V_{dc} \cdot (R_{sys-} / (R_{sys++} + R_{sys-}))$	914.07	V	
V2	Thevenin equiv. V2	$=V_{imd-} + (V_{dc} - V_{imd+} - V_{imd-}) \cdot (R_{imd-} / (R_{imd++} + R_{imd-}))$	410	V	
V1_nh	V1 without human	$=V_{dc} \cdot (R_{sys-} / (R_{sys+nh} + R_{sys-}))$	216.470	V	
Vpe	Vpe vs Vd.c.-	$=V_2 + (V_1 - V_2) \cdot (R_{imd} / (R_{sys+} + R_{imd}))$	909.939	V	
Vpe_nh	Vpe without human	$=V_2 + (V_1_{nh} - V_2) \cdot (R_{imd} / (R_{sys_nh} + R_{imd}))$	312.277	V	
Ih	Steadystate body current	$=(V_{dc} - V_{pe}) / R_h$	0.020 12	A	25 mA, Max
Ipk	Peak body current	$=(V_{dc} - V_{pe_nh}) / R_h$	1.215 44	A	
Ipk_rms	RMS body current	$=I_{pk} / \sqrt{6}$	0.496 20	A	0.5 A Max, for >4 ms, see Fig. 20 of IEC 60479-2
T3RC	Duration of impulse	$=3 \cdot (1 / ((1/R_{sys}) + (1/R_{imd}))) \cdot C_{tot}$	7.38E-03	s	
E	Energy through body	$=(V_{dc} - V_1_{nh})^2 - (V_{dc} - V_1)^2 \cdot 0.5 \cdot C_{tot}$	1.24	J	

A-4.8 PE Loss Reaction

The d.c. electric vehicle supply equipment shall trigger an emergency shutdown within 70 ms if a loss of electrical continuity of the protective conductor occurs anywhere from the inside of the d.c. electric vehicle supply equipment up to the point PP (see Fig. 19).

The electric vehicle shall monitor the electrical continuity of the protective conductor from point PP to the electric vehicle by doing the following:

- The electric vehicle shall check before each initiation of charging the PP circuit for correct values, this includes the continuity of the PE from the point PP up to the electric vehicle; and
- The electric vehicle shall either open switch spp when it changes the CP state from B to C or the electric vehicle shall check the PP circuit during charging and in

case of a PE loss, the electric vehicle shall trigger an emergency shutdown within 70 ms.

A-5 ADDITIONAL FUNCTIONS

A-5.1 Pre-Charging

While executing the pre-charge sequence, the EVSE shall comply with the pre-charge request process as stated in the communication protocol but the current request of the electric vehicle shall be ignored and the output current shall be limited to 2 A.

During pre-charge, the EVSE shall:

- be able to pre-charge the circuit defined in Fig. 27 with the values according to Table 23 for its entire operating range within 3 s; and subsequently; and
- follow the voltage request from the electric vehicle according to 101.2.2.2 and 101.2.6 within 1 s.

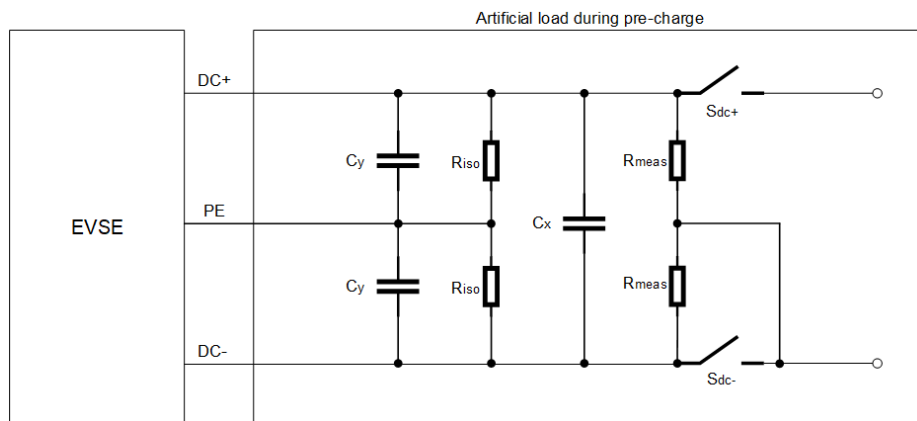

Key

- C_y Maximum electric vehicle Y-capacitor on inlet
- C_x Maximum electric vehicle X-capacitor on inlet
- R_{iso} Minimum insulation resistance (due to an error) on inlet
- R_{meas} Minimum resistance for electric vehicle measurement circuit on inlet
- S_{dc-} d.c. - disconnection device of the electric vehicle
- S_{dc+} d.c. + disconnection device of the electric vehicle

FIG. 27 WORST CASE EQUIVALENT CIRCUIT FOR THE EV DURING THE PRE-CHARGE PROCESS

Table 23 Values to Design the EV and EVSE During Pre-Charge Based on Fig. 27

(Clause A-5.1)

SI No.	Symbol	Value used by EVSE	Value used by Electric Vehicle
(1)	(2)	(3)	(4)
i)	C_y	2 μ F	$\leq 2 \mu$ F
ii)	C_x	10 nF (tbc)	≤ 10 nF
iii)	R_{iso}	≥ 100 k Ω	see ISO 17409
iv)	R_{meas}	500 k Ω	≥ 500 k Ω
v)	S_{dc-}	closed	-
vi)	S_{dc+}	open	-

During pre-charge, the electric vehicle shall limit its current draw to an equivalent of the circuit defined in Fig. 27 and Table 23.

This is needed to charge all the elements within the d.c. bus of the EVSE and electric vehicle connection (Y Caps, cable caps, and other components).

According to ISO 17409, the electric vehicle shall close its disconnection device only after verifying that the absolute voltage difference between the electric vehicle inlet and the electric vehicle battery is less than 20 V.

The electric vehicle should be protected against the

case that the polarity of the d.c. output is reversed and shall not close its disconnection device.

The electric vehicle shall measure the d.c. bus voltage at its inlet and could use the measured voltage as feedback for the pre-charge request adjustments.

The electric vehicle shall not solely use the voltage measurements communicated by the EVSE to check if the EVSE output and battery voltages are within this limit. As the voltage across the electric vehicle contactors are leading for closing the electric vehicle contactors.

Figure 28 shows the schematics for the voltage measurement points.

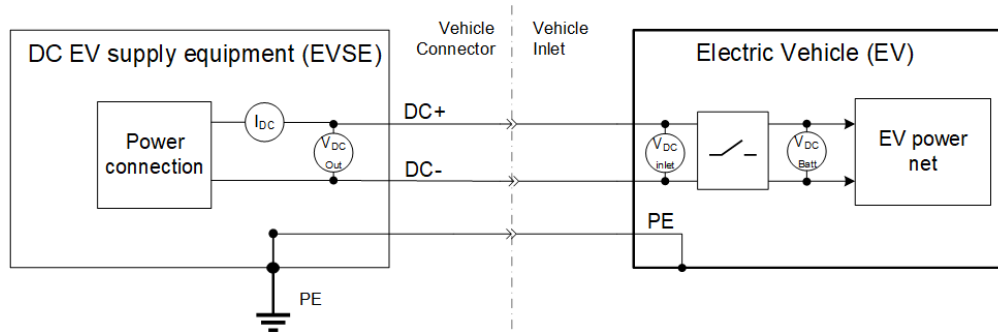

FIG. 28 VOLTAGE MEASUREMENT POINTS FOR THE PRE-CHARGE PROCESS

The electric vehicle could consider to do pre-charge voltage request adjustment to compensate for tolerances and steady state errors to get the inlet voltage within ± 20 V of the battery voltage.

Compliance is checked by [A-9.3.13](#)

A-5.2 Wake Up

The d.c. electric vehicle supply equipment may support a sleep mode according to IS/ISO 15118-3 : 2015 to minimize power consumption as described as an optional function in [6.3.2.101](#).

The d.c. electric vehicle supply equipment may enter a sleep mode, if:

- a) the vehicle attached to the d.c. electric vehicle supply equipment has not changed the control pilot from state B2 to C2 or D2 for more than 2 min without the occurrence of any communication-based timeout; and
- b) the vehicle commands a paused V2G charging session according to [8.4.2](#) of IS/ISO 15118-2 : 2018.

During sleep mode the PWM oscillator shall be off while CP voltage is set to constant voltage (CP state x1) in order to allow:

- a) waking up the d.c. electric vehicle supply equipment by the electric vehicle using B1 – C1 – B1 toggling according to IS/ISO 15118-3. After a successful wake up, the d.c. electric vehicle supply equipment shall enable the PWM oscillator with a duty cycle of 5 percent; and
- b) waking up the electric vehicle by the d.c. electric vehicle supply equipment using B1 – B2 change, according to Table [A-6](#) sequence and 3.1 of Annex A of IS 17017 (Part 1) : 2018. If the d.c. electric vehicle supply equipment has turned off its CP oscillator then it shall stay in B1 for at least 3 s according to Table [A-6](#) sequence 9.2 of Annex A of IS 17017 (Part 1) : 2018. After

a successful wake up, the electric vehicle resumes digital communication. The d.c. electric vehicle supply equipment may additionally consider [A-5.3](#) of IS 17017 (Part 1) : 2018 (information on difficulties encountered with some legacy electric vehicles for wake-up after a long period of inactivity).

Compliance is checked by [A-9.3.2](#).

A-5.3 Handling of Operating Ranges

A-5.3.1 0 A Mode during Energy Transfer

If the d.c. electric vehicle supply equipment cannot deliver any current, it shall send 0A as its maximum output current limit to the electric vehicle within the next communicated message. The 0A mode initiated by the d.c. electric vehicle supply equipment shall not trigger an immediate shutdown by the electric vehicle. The electric vehicle should continue the charging session for at least 5 min.

If the electric vehicle requests 0A or the d.c. electric vehicle supply equipment is limited to 0A, then the d.c. electric vehicle supply equipment shall reduce and maintain its d.c. output current to below 0.15 A with a minimum of - 0.15 A, to prevent reverse power flow from the electric vehicle to the d.c. electric vehicle supply equipment. See [A-5.3.5](#) regarding the 0A request from the electric vehicle.

NOTE — The 0A mode is used to temporarily charge without current being delivered. For example, when there are power fluctuations in the electric grid or there is no power available.

A-5.3.2 Changing Maximum Output Current

The d.c. electric vehicle supply equipment is allowed to deliver less current than the requested current by the electric vehicle if its maximum output current limit is below the electric vehicle current request.

The d.c. electric vehicle supply equipment shall communicate the change of maximum output current limit in the next communicated message.

A-5.3.3 Changing Maximum Output Power

The d.c. electric vehicle supply equipment is allowed to deliver less current than the current requested by the electric vehicle if the d.c. electric vehicle supply equipment’s maximum output power limit drops below the present output power delivered to the electric vehicle.

The EVSE shall communicate the change of the maximum output power limit in the next communicated message.

A-5.3.4 d.c. EV Supply Equipment Delivers Less Current than EV Current Request

If the d.c. electric vehicle supply equipment delivers less current than the target current request from the electric vehicle, this shall not result in a shutdown triggered by the electric vehicle.

NOTE — This decrease in output current can be caused by grid dips, CVC mode or a change in maximum output current. See [A-5.3.2](#).

A-5.3.5 EV Requests a Current below d.c. EV Supply Equipment Minimum Output Current

The d.c. electric vehicle supply equipment shall go into 0A mode (see [A-5.3.1](#)), as if the electric vehicle requested 0A, when the d.c. electric vehicle supply equipment receives a current request below its minimum output current.

$$I_{EVSE_Out} = 0 \text{ if } I_{EV_Req} < I_{EVSE_Min}$$

where

I_{EVSE_Out} : Output current of the d.c. electric vehicle supply equipment;

I_{EVSE_Min} : Minimum output current limit of the d.c. electric vehicle supply equipment; and

I_{EV_Req} : Target current request from the electric vehicle.

A-5.3.6 EV Requests a Current above d.c. EV Supply Equipment Maximum Output Current

The d.c. electric vehicle supply equipment shall continue the charge session with its maximum output current or the maximum current from the electric vehicle, whichever is less, if the electric vehicle requests a current higher than these maximum current limits:

$$I_{EVSE_Out} = \text{MIN}(I_{EV_MAX}, I_{EVSE_MAX}) \text{ if } I_{EV_req} > \text{MIN}(I_{EV_MAX}, I_{EVSE_MAX})$$

where

I_{EVSE_Out} : Output current of the d.c. electric vehicle supply equipment;

I_{EVSE_MAX} : Maximum output current from the d.c. electric vehicle supply equipment;

I_{EV_MAX} : Maximum input current from the electric vehicle; and

I_{EV_req} : Target current request from the electric vehicle.

A-5.3.7 Output Voltage d.c. EV Supply Equipment Higher than Maximum Output Voltage

The d.c. electric vehicle supply equipment shall trigger an error shutdown within 10 ms if the measured output voltage is equal or higher than the maximum output voltage of the d.c. electric vehicle supply equipment for more than 400 ms:

Error Stop if $V_{EVSE_measured} \geq V_{EVSE_MAX}$ for more than 400 ms.

where

$V_{EVSE_Measured}$: Output voltage measured by the d.c. electric vehicle supply equipment; and

V_{EVSE_MAX} : Maximum output voltage of the d.c. electric vehicle supply equipment.

A-5.3.8 Output Voltage of d.c. EV Supply Equipment is below its Minimum Output Voltage

The d.c. electric vehicle supply equipment shall trigger an error shutdown within 10 ms if the measured output voltage or the requested output voltage by the electric vehicle is lower than the minimum output voltage of the d.c. electric vehicle supply equipment for more than 3 s.

Error Stop if $\text{MIN}(V_{EVSE_measured}, V_{EV_req}) < V_{EVSE_MIN}$ for more than 3 s

where

$V_{EVSE_Measured}$: Output voltage measured by the d.c. electric vehicle supply equipment;

V_{EVSE_MIN} : Minimum Output voltage of the d.c. electric vehicle supply equipment; and

V_{EV_Req} : Target voltage request from the electric vehicle.

NOTE — This case could be detected during the pre-charge stage, as the d.c. electric vehicle supply equipment cannot supply the correct voltage for pre-charge.

A-5.3.9 EV Requests a Voltage Above the Maximum Voltage Limits

The d.c. electric vehicle supply equipment shall continue the charge session with the maximum

output voltage if the electric vehicle requests a voltage higher than the maximum output voltage of the d.c. electric vehicle supply equipment.

The d.c. electric vehicle supply equipment shall continue to charge with the requested output voltage from the electric vehicle or the d.c. electric vehicle supply equipment's maximum output voltage, whichever is less, if the electric vehicle requests a voltage higher than the maximum battery voltage:

$$V_{EVSE_Out} = \text{MIN}(V_{EV_Req}, V_{EVSE_Max}) \quad \text{if } V_{EV_req} > V_{EV_Max}$$

where

- V_{EVSE_Out} : Output voltage of the d.c. electric vehicle supply equipment;
- V_{EVSE_Max} : Maximum output voltage of the d.c. electric vehicle supply equipment;
- V_{EV_Req} : Target voltage request from the electric vehicle; and
- V_{EV_Max} : Maximum battery voltage of the electric vehicle.

NOTE — The d.c. electric vehicle supply equipment can remain in CCC mode until the maximum battery voltage is reached. See overvoltage protection in [6.3.1.106](#), which prevents overcharging the electric vehicle battery.

A-5.3.10 Limitations Minimum Power

The d.c. electric vehicle supply equipment shall go into 0A mode (see [A-5.3.1](#)), as if the electric vehicle requested 0a, if:

- a) the requested power by the electric vehicle is below the minimum output power of the d.c. electric vehicle supply equipment; or
- b) for more than 3 s, the measured output voltage multiplied by the requested output current is below the minimum output power of the d.c. electric vehicle supply equipment.

$$I_{EVSE_Out} = 0 \quad \text{if } P_{EV_Req} < P_{EVSE_MIN}, \text{ or}$$

$$I_{EVSE_Out} = 0 \quad \text{if } V_{EVSE_Measured} * I_{EV_Req} < P_{EVSE_MIN}$$

for more than 3s

where

- I_{EVSE_Out} : Output current of the d.c. electric vehicle supply equipment;
- I_{EV_Req} : Target current requested by the electric vehicle;
- $V_{EVSE_Measured}$: Output voltage measured by the d.c. electric vehicle supply equipment;
- P_{EV_Req} : Power requested by the electric vehicle; and
- P_{EVSE_MIN} : Minimum power output of the d.c. electric vehicle supply equipment.

NOTE — P_{EVSE_MIN} is the internal minimum power that the d.c. electric vehicle supply equipment can deliver as this value is not handled by the communication, but is restricting the output. The d.c. electric vehicle supply equipment cannot know the minimum and actual battery voltages as these are not communicated through HLC.

A-5.3.11 Limitations due to Maximum Power

If the electric vehicle requests a power output or current multiplied by the measured voltage that is higher than the power limits of the electric vehicle or d.c. electric vehicle supply equipment, then the d.c. electric vehicle supply equipment shall continue the charge session and limit its output power to the minimum of the following values:

- a) Electric vehicle maximum power; and
- b) d.c. electric vehicle supply equipment maximum power output.

$$P_{EVSE_out} = \text{MIN}(P_{EV_MAX}, P_{EVSE_MAX}), \quad \text{if}$$

$$\text{MIN}(V_{EVSE_measured} * I_{EV_req}, P_{EV_req}) > \text{MIN}(P_{EV_MAX}, P_{EVSE_MAX})$$

where

- $V_{EVSE_Measured}$: Output voltage measured by the d.c. electric vehicle supply equipment;
- I_{EV_Req} : Target current requested by the electric vehicle;
- P_{EVSE_out} : Output power delivered by the d.c. electric vehicle supply equipment;
- P_{EVSE_MAX} : Maximum power output of the d.c. electric vehicle supply equipment;
- P_{EV_Req} : Power requested by the electric vehicle; and
- P_{EV_MAX} : Maximum power requested by the electric vehicle.

NOTE — According to IS/ISO 15118-2, the P_{EV_Req} is the electric vehicle's maximum power limit within the current demand messages and the P_{EV_MAX} is the electric vehicle maximum power limit communicated.

A-6 SPECIFIC REQUIREMENTS

A-6.1 Turn on Inrush Current (d.c. Output)

Any inrush current on d.c. output in both directions when closing of electric vehicle disconnection device and d.c. electric vehicle supply equipment contactors, if any, shall be limited by the d.c. electric vehicle supply equipment to 2 A, for example, by applying a pre-charging circuit as shown in [Fig. 23](#).

NOTE — Higher current values for short time under 1 ms can appear for charging and discharging of cable capacitance.

A-6.2 Requirements for Load Dump

In any case of load dump, voltage overshoot shall not exceed 110 percent of the maximum voltage

limit of the vehicle, as communicated during the initialisation phase, or maximum voltage limit of the vehicle, as communicated during the initialisation phase, + 50 V whichever is higher (see [101.2.7](#)).

If the electric vehicle battery gets disconnected from the d.c. output during charging, the electric vehicle shall perform an error shutdown before re-initiating charging.

A-6.3 d.c. Output Current Regulation

When in current regulation mode, the d.c. electric vehicle supply equipment shall provide direct current to the vehicle. The maximum allowable error between the output current and the target current requested by the vehicle is:

- a) ± 150 mA when the commanded current value is less than or equal to 5 A;
- b) ± 1.5 A when the commanded current value is greater than 5 A but less than or equal to 50 A; and
- c) ± 3 percent of the d.c. electric vehicle supply equipment's maximum current output when the commanded current value is greater than 50 A.

A-6.4 Measuring Current and Voltage

The accuracy of output measurement of system C shall be within the following values:

- a) Voltage: within ± 10 V; and
- b) Current: within ± 1.5 percent of reading or within ± 0.5 A, whichever is higher

After a value is measured by the d.c. electric vehicle supply equipment, it shall be send within 200 ms to the electric vehicle or it is remeasured before sending it to the electric vehicle.

The electric vehicle should not solely rely on the

voltage and current measurements from the d.c. electric vehicle supply equipment for charge session control.

A-6.5 Overcurrent Protection of d.c. Connection

The d.c. electric vehicle supply equipment shall provide an over-current protection to protect the power supply circuit of the d.c. electric vehicle supply equipment and the vehicle.

If one or both of the following conditions are continuously fulfilled for a duration of 0.5 s, the d.c. electric vehicle supply equipment shall trigger an emergency shutdown within 0.5 s:

- a) current is exceeding 120 percent of the maximum operating current of the station; and
- b) during energy transfer the voltage is dropping below 80 percent of the minimum operating voltage of the station.

NOTE — For the protective measures in the vehicle, see [6.2](#) of ISO 17409 : 2020.

Compliance is tested by [A-9.3.18](#).

A-7 SCHEMATICS AND DESCRIPTION

Schematics of System C for d.c. electric vehicle supply equipment is given in [Fig. 29](#), as well definition and description of symbols and terms in [Table 24](#).

A-8 REQUIREMENTS FOR HIGH-LEVEL COMMUNICATION OF d.c. EV SUPPLY EQUIPMENTS USING CHARGING WITH THERMAL MANAGEMENT SYSTEM

For charging with thermal management system, the high-level communication shall be implemented according to IS/ISO 15118-2 to exchange additional information.

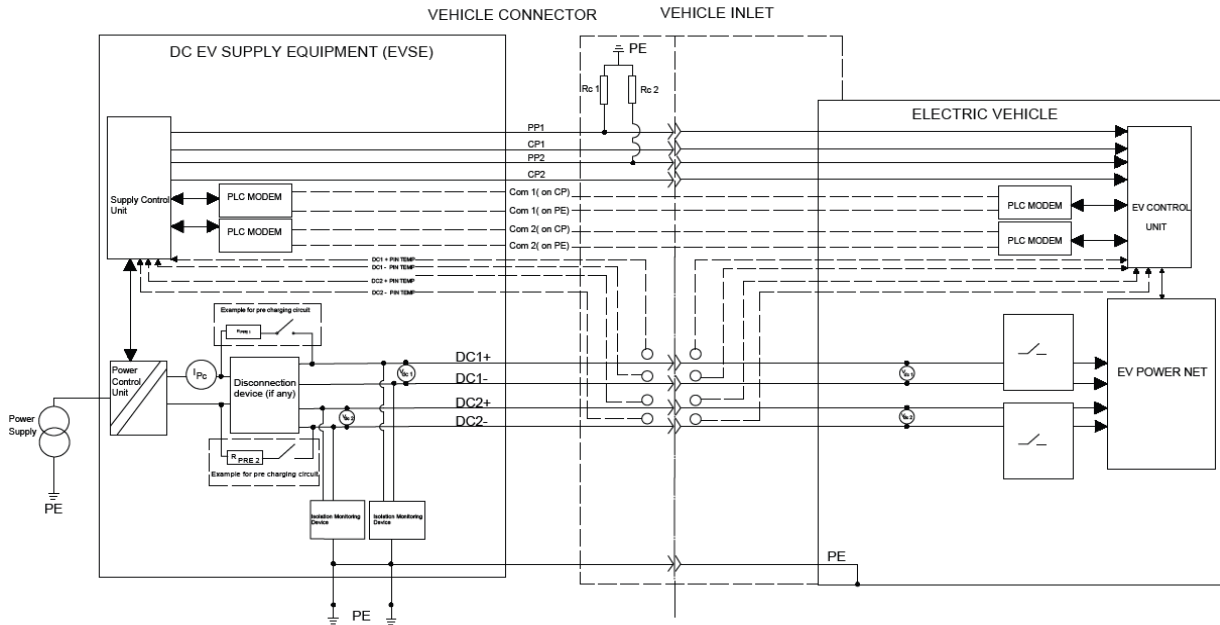

NOTES

- 1 The supply disconnection device may be substituted by a diode, while the inrush current requirements in A-6 have to be fulfilled.
- 2 Diagram shows functional description of interface. Contact assignment of vehicle coupler is done in IS 17017 (Part 2/Sec 3).
- 3 PP line from vehicle connector to d.c. electric vehicle Supply equipment is optional for configuration FF couplers.

FIG. 29 SYSTEM SCHEMATIC EXAMPLE OF SYSTEM C

Table 24 Definition and Description of Symbols/Terms

(Clause [A-7](#))

SI No.	d.c. EV Supply Equipment		Electric Vehicle (EV)		Interface Circuit	
	Symbols/Terms	Definitions	Symbols/Terms	Definitions	Symbols/Terms	Definitions
(1)	(2)	(3)	(4)	(5)	(6)	(7)
i)	V1_d.c./V2_d.c.	Voltage Measurement at output of d.c. Electric Vehicle supply equipment	PLC Modem (Electric Vehicle)	Electric Vehicle communication interface between PLC and internal Electric Vehicle communication	PE	Protective conductor
ii)	I1_d.c./I2_d.c..	Current measurement (on d.c.+ or d.c.- or both)	Electric Vehicle control unit	Unit for communicating from Electric Vehicle to the d.c. Electric Vehicle supply equipment and verifying safety procedure	d.c.+	d.c. power supply (positive)
iii)	Power Conversion Unit	Isolated power stage for converting a.c. supply network into regulated d.c. power for Electric Vehicle supplying	Electric Vehicle power net	Subsystem within the Electric Vehicle related to be supplied with energy from the d.c. Electric Vehicle supply equipment.	d.c.-	d.c. power supply (negative)
iv)	Disconnection device	Device to connect and disconnect d.c. output of d.c. Electric Vehicle supply equipment to power conversion unit a)			Com1	(positive) line for (PLC) c)
v)	PLC Modem for Gun1/Gun2 (Supply)	Supply communication interface between PLC and internal supply communication			Com2	(negative) line for PLC
vi)	Supply Control Unit	Unit for control of Supply process within d.c. Electric Vehicle supply equipment and communicating with Electric Vehicle			PP (Proximity)	General functions according to IS 17017 (Part 1) : 2018 with definition of values in Table 13 for configurations FF

Table 24 (Concluded)

SI No.	d.c. EV Supply Equipment		Electric Vehicle (EV)		Interface Circuit	
	Symbols/Terms	Definitions	Symbols/Terms	Definitions	Symbols/Terms	Definitions
(1)	(2)	(3)	(4)	(5)	(6)	(7)
vii)	R_pre	Resistor for pre charging circuit b)			CP (control pilot)	Function according to IS 17017 (Part 1) : 2018 Also used for emergency shutdown of d.c. electric vehicle supply equipment by electric vehicle going into state B or interruption of control pilot for CP lost shutdown.
viii)	IMD1/ IMD2	Insulation monitoring device			RC	Proximity-resistor used for coding of cable current capability in case of a.c. supply according to values in IS 17017 (Part 1) : 2018.
ix)					CCL (correct contact and latching)	Feedback of correct contact and latching of d.c. vehicle connector
x)						Thermal sensing

a The disconnection device may be substituted by a diode.

b Switch and resistor are recommended for implementation of mandatory pre charging function.

c Refer to Table 12 for different connectors.

A-9 GENERAL TEST CONDITIONS

A-9.1 Operating Range

A-9.1.1 Definition

Definitions of variables are as follows:

$V_{EVSE\ intended}$	voltage value of testing point
$I_{EVSE\ intended}$	current value of testing point
$V_{EV\ target}$	requested output voltage by the testing system, sent to the d.c. electric vehicle supply equipment via digital communication
$I_{EV\ target}$	requested output current by the testing system, sent to the d.c. electric vehicle supply equipment via digital communication
$V_{EVSE\ Output}$	Output voltage of the d.c. electric vehicle supply equipment measured by the testing system
$I_{EVSE\ Output}$	Output current of the d.c. electric vehicle supply equipment measured by the testing system
$V_{EV\ max}$	maximum operating voltage of electric vehicle
$I_{EV\ max}$	maximum operating current of electric vehicle

The values for $V_{EV\ max}$ and $I_{EV\ max}$ shall be set to the maximum corresponding values of the d.c. electric vehicle supply equipment transferred via digital communication (for example, charge parameter discovery res) unless otherwise specified.

If the d.c. electric vehicle supply equipment shows any discontinuous behaviour in its operating range, for example, in case of cascaded architecture of power modules, it might be necessary to add additional testing points. In case that the operating area boundaries are reached, additional operating points or shifting of existing points shall be performed in order to fulfil the test requirements.

A-9.3 Test Cases

A-9.3.1 Compatibility Assessment

The compliance test is shown in Table 25.

A-9.2 Test Setup

A-9.2.1 Standard Test Setup

Figure 31 shows standard test setup.

A-9.3.2 Wake up of d.c. EV Supply Equipment by EV

The compliance test is shown in [Table 26](#).

A-9.3.3 Details of Pilot Function

The compliance test is shown in [Table 27](#).

A-9.3.4 Protective Conductor Continuity Checking

The compliance test is shown in [Table 28](#).

A-9.3.5 Rated Outputs and Maximum Output Power

The compliance test is shown in [Fig. 32](#) and [Table 29](#).

A-9.3.6 Protection Against Overvoltage at the Interface

The compliance test is shown in [Table 30](#).

A-9.3.7 Emergency Shutdown in Case of Control Pilot Disconnection

The compliance test is shown in [Table 31](#).

A-9.3.8 Load Dump

The compliance test is shown in [Table 32](#).

A-9.3.9 Protection against Uncontrolled Reverse Power Flow from Vehicle

The compliance test is shown in [Table 33](#).

A-9.3.10 Limiting Inrush Current by d.c. EV Supply Equipment to 2A

The compliance test is shown in [Table 34](#).

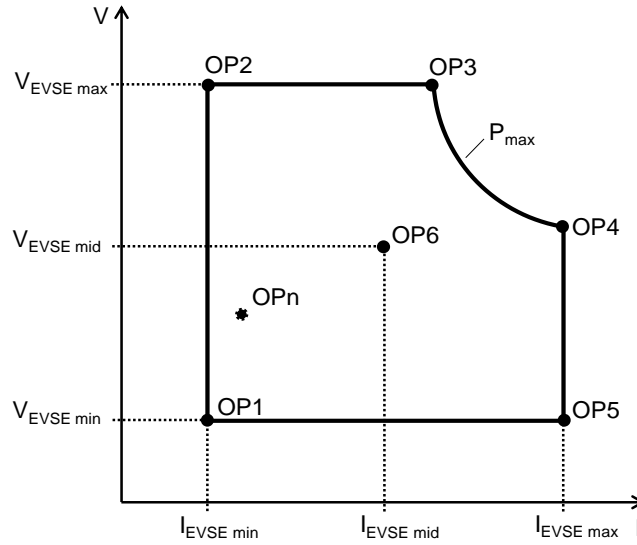

Key

$I_{EVSE\ max}$	maximum operating current of electric vehicle supply equipment	OP1	$V_{EVSE\ min}$ and $I_{EVSE\ min}$
$I_{EVSE\ mid}$	$(I_{EVSE\ max} + I_{EVSE\ min}) / 2$	OP2	$V_{EVSE\ max}$ and $I_{EVSE\ min}$
$I_{EVSE\ min}$	minimum operating current of electric vehicle supply equipment	OP3	$V_{EVSE\ max}$ and P_{max}
$V_{EVSE\ max}$	maximum operating voltage of electric vehicle supply equipment	OP4	$I_{EVSE\ max}$ and P_{max}
$V_{EVSE\ mid}$	$(V_{EVSE\ max} + V_{EVSE\ min}) / 2$	OP5	$V_{EVSE\ min}$ and $I_{EVSE\ max}$
$V_{EVSE\ min}$	minimum operating voltage of electric vehicle supply equipment	OP6	$V_{EVSE\ mid}$ and $I_{EVSE\ mid}$
OP	operation point		
OPn	voltage and current depending on test conditions		

NOTE — The defined operating range (OP1 - OP5) specifies the possible range for the electric vehicle to request values for voltage and/or current. Within the tolerances, the d.c. EV supply equipment however is allowed to deliver values for current or voltage that are outside of this operating range.

FIG. 30 OPERATING POINTS

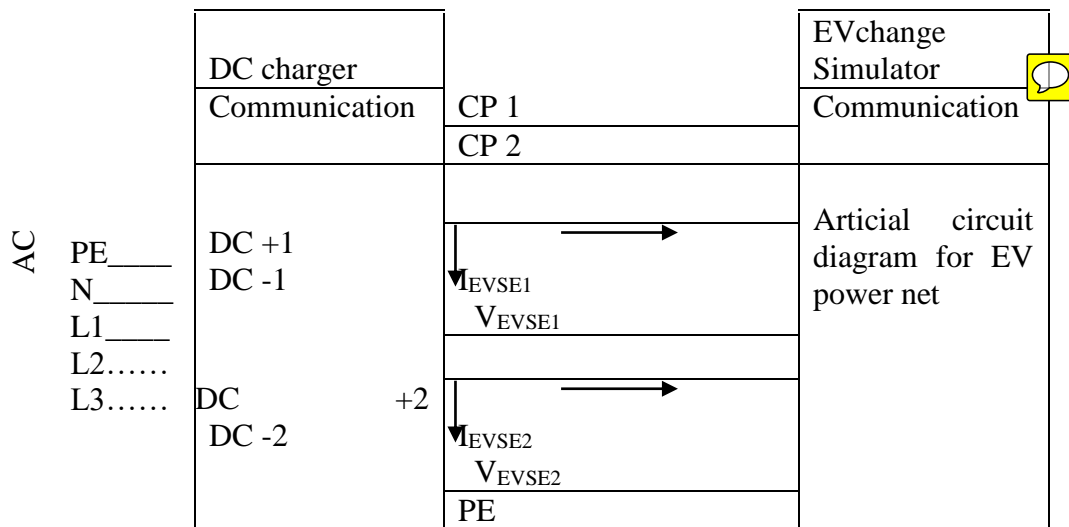



FIG. 31 STANDARD TEST SETUP CIRCUIT DIAGRAM

Table 25 Compliance test for Compatibility Assessment

(Clause [A-9.3.1](#))

Matching to requirement (chapter)	<p>6.3.1.104 Compatibility assessment</p> <p>102.5.2 Description of the process before the start of charging (initialization) </p> <p>B-3.2 normal start up</p> <p>B-3.3 normal shut down</p>
Short description	
<p>Test, if d.c. Electric Vehicle Supply equipment will not proceed with the charging process in case of:</p> $V_{EVSE\ min} > V_{EV\ max}$	
Pre-conditions	
for IS/ISO 15118, message “AuthorisationRes” was successfully received by Electric Vehiclesimulator	
Test setup	
Standard test setup, additionally measurement equipment for output voltage $V_{EVSE\ Output}$ (continuously measured)	
Action(s)	
<p>for IS/ISO15118-2:</p> <p>send message “ChargeParameterDiscovery.req” containing the following specific value for d.c._EV ChargeParameterType:</p> <p>Electric vehicle maximum voltage limit = $\max(V_{EVSE\ min} - 10V, 0V)$</p> <p>proceed with the digital communication according to each standard.</p>	
Expected results	
<p>d.c. electric vehicle supply equipment will not proceed with the next message via digital communication according to each standard.</p> <p>ChargeParameterDiscovery.Res contain an EVSE status code = ”EVSE_Shutdown”</p> <p>$V_{EVSE\ Output} < 60\ V\ d.\ c.$</p>	
Post conditions	
none	

NOTE — It may be noted that the above sequence shall be followed by both the charging guns. There shall be a time difference of “t” sec between SECC1 and SECC2 as specified by OEMs.

Table 26 Compliance Test for Wake up of d.c. EV Supply Equipment by EV(Clause [A-9.3.2](#))

Matching to requirement (chapter)	A-5.2 Wake up of d.c. electric vehicle supply equipment by electric vehicle
Short description	
Reaction on wake up action performed by electric vehicle after d.c. electric vehicle supply equipment fell asleep.	
Pre-conditions	
<p>The d.c. electric vehicle supply equipment has successfully transmitted its following properties to the EV-simulator:</p> <p>$V_{EVSE\ min}$, $V_{EVSE\ max}$, $I_{EVSE\ min}$, $I_{EVSE\ max}$, $P_{EVSE\ max}$</p> <p>The charging sequence shall be successfully done until $t=8$ according to Fig. 21, including the message “PowerDeliveryReq” (according to IS/ISO 15118), with the following values used during pre-charging:</p> $V1 = V_{EVSE\ min} - (R1 + R2) \times I_{EVSE\ min} \quad \text{if} \quad V_{EVSE\ min} \geq (R1 + R2) \times I_{EVSE\ min}$ <p>and:</p> $V1 = 0\ V \text{ if } V_{EVSE\ min} < (R1 + R2) \times I_{EVSE\ min}$ <p>and the parameters “EV_{TargetVoltage}” in message “PreChargeReq” (according to IS/ISO 15118):</p> $EV_{TargetVoltage} = V_{EV\ target} = V_{EVSE\ min}$	
Test setup	
Standard test setup	
Test Action(s)	
<p>In each test step, the EV-simulator shall issue current requests and, if applicable voltage requests.</p> <p>The message “CurrentDemandReq” according to IS/ISO 15118-2 shall contain the following parameters:</p> $EV_{TargetCurrent} = I_{EV\ target}$ $EV_{TargetVoltage} = V_{EV\ target}$ <p>Definition of intended test point (OP5):</p> $I_{EVSE\ intended} = I_{EVSE\ max}$ $V_{EVSE\ intended} = V_{EVSE\ min}$ <p>1) Set:</p> $V1 = V_{EVSE\ min} - (R1+R2) \times I_{EVSE\ max}$ <p>If $V_{EVSE\ min} - (R1+R2) \times I_{EVSE\ max} \geq 0V$</p> <p>2) Send:</p> $I_{EV\ target} = I_{EVSE\ max}$ $V_{EV\ target} = \min (P_{EVSE\ max}/I_{EVSE\ max}; V_{EVSE\ max})$ <p>3) Wait for T_{wait} (<i>see</i> definition below) in order to reach steady state operation before measuring</p> $T_{wait} = 2\ s + 1.1 \times I_{EVSE\ max} / 20\ A/s$	

Table 26 (Concluded)

<p>The test system sends message “PowerDeliveryReq” according to IS/ISO 15118-2 with the parameter “ChargeProgress” set to “Stop” and waits for “PowerDeliveryRes”</p> <p>After receiving “PowerDeliveryRes” the test system sends message “SessionStopReq” according to IS/ISO 15118-2 with the parameter “ChargingSession” set to “Pause”</p> <p>Test system pauses the Data-Link [D-LINK_PAUSE.request ()] after receiving SessionStopRes</p> <p>d.c. EV Supply equipment changes to sleep mode, which is indicated by a disabled PWM oscillator while CP voltage is set to constant +12 V.</p> <p>Test system performs one B1-C1-B1 toggle according to IS/ISO 15118-3 : 2015.</p>
Expected results
d.c. EV supply equipment signals wake up by enabling the PWM oscillator with a duty cycle of 5 percent.

NOTE — It may be noted that the above sequence shall be followed by both the charging guns. There shall be a time difference of “t” sec between SECC1 and SECC2 as specified by OEMs.

Table 27 Compliance Test for Details of Pilot Function

(Clauses [A-4.7](#) and [A-9.3.3](#))

Matching to requirement (chapter)	6.3.1.5 De-energization of the power supply to the EV
Short description	
Start of d.c. charging impossible in case of CP lost	
Pre-conditions	
<p>The electric vehicle supply equipment has successfully transmitted its following properties to the EV-simulator: $V_{EVSE\ min}$, $V_{EVSE\ max}$, $I_{EVSE\ min}$, $I_{EVSE\ max}$, $P_{EVSE\ max}$</p> <p>The charging sequence shall be successfully done until $t = t1$ according to Fig. 21.</p>	
Test setup	
Standard test setup, additional relay for opening CP	
<p>The diagram shows a DC charger on the left and an EVchange Simulator on the right. The DC charger has AC inputs (PE, N, L1, L2, L3) and DC outputs (DC +1, DC -1, DC +2, DC -2, PE). The EVchange Simulator has Communication ports and CP 1, CP 2. Connections include DC +1 to CP 1, DC -1 to CP 2, DC +2 to CP 1, and DC -2 to CP 2. Currents I_{EVSE1} and I_{EVSE2} are shown flowing from the DC charger to the simulator. A note indicates this is an 'Artificial circuit diagram for EV power net'.</p>	
Action(s)	
Interrupt control pilot	
Expected results	
The d.c. electric vehicle supply equipment shall stop the ongoing charging session.	

NOTE — It may be noted that the above sequence shall be followed by both the charging guns. There shall be a time difference of “t” s between SECC1 and SECC2 as specified by OEMs.

Table 28 Compliance Test for Protective Conductor Continuity Checking

(Clause [A-9.3.4](#))

Matching to requirement (chapter)	<p>6.3.1.2 Continuous continuity checking of the protective conductor</p> <p>6.3.1.112 and 6.3.1.113 Voltage limitation between d.c. output and protective conductor</p>
Short description	
Emergency shutdown in case of loss of protective conductor continuity. This test case applies to d.c. electric vehicle supply equipments with a maximum output voltage ≥ 60 V.	
Pre-conditions	
<p>The d.c. electric vehicle supply equipment has successfully transmitted its following properties to the EV-simulator:</p> <p>$V_{EVSE\ min}$, $V_{EVSE\ max}$, $I_{EVSE\ min}$, $I_{EVSE\ max}$, $P_{EVSE\ max}$</p> <p>The charging sequence shall be successfully done until $t=t8$ according to Fig. 21, including the message “PowerDeliveryReq” (according to IS/ISO 15118), with the following values used during pre-charging:</p> <p>$V1 = V_{EVSE\ min} - (R1 + R2) \times I_{EVSE\ min}$ if $V_{EVSE\ min} \geq (R1 + R2) \times I_{EVSE\ min}$</p> <p>and:</p> <p>$V1 = 0$ V if $V_{EVSE\ min} < (R1 + R2) \times I_{EVSE\ min}$</p> <p>and the parameters “EVTargetVoltage” in message “PreChargeReq” (according to IS/ISO 15118):</p> <p>$EV_{TargetVoltage} = V_{EV\ target} = V_{EVSE\ min}$</p>	
Test setup	
Standard test setup with additional relay for interruption of protective conductor continuity.	
<p>The maximum emergency shutdown time $t_{shutdown}$ is determined by the following equation:</p> <p>$t_{shutdown} = t_{trigger} + t_{perform}$</p> <p>with: $t_{trigger} = 10$ ms for isolated systems</p>	

Table 28 (Concluded)

$t_{\text{perform}} = 30 \text{ ms}$
Action(s)
<p>In each test step, the EV-simulator shall issue current requests and, if applicable voltage requests.</p> <p>The message “CurrentDemandReq” according to IS/ISO 15118 shall contain the following parameters:</p> <p>$EV_{\text{TargetCurrent}} = I_{EV \text{ target}}$</p> <p>$EV_{\text{TargetVoltage}} = V_{EV \text{ target}}$</p> <p>Definition of intended test point (OP5):</p> <p>$I_{EVSE \text{ intended}} = I_{EVSE \text{ max}}$</p> <p>$V_{EVSE \text{ intended}} = V_{EVSE \text{ min}}$</p> <p>1) Set:</p> <p>$V1 = V_{EVSE \text{ min}} - (R1+R2) \times I_{EVSE \text{ max}}$</p> <p>If $V_{EVSE \text{ min}} - (R1+R2) \times I_{EVSE \text{ max}} \geq 0 \text{ V}$</p> <p>2)Send:</p> <p>$I_{EV \text{ target}} = I_{EVSE \text{ max}}$</p> <p>$V_{EV \text{ target}} = \min (P_{EVSE \text{ max}}/I_{EVSE \text{ max}}; V_{EVSE \text{ max}})$</p> <p>3) Wait for T_{wait} (see definition below) in order to reach steady state operation before measuring</p> <p>$T_{\text{wait}} = 2 \text{ s} + 1.1 \times I_{EVSE \text{ max}} / 20 \text{ A/s}$</p> <p>4) Interrupt protective conductor inside EV-simulator</p>
Expected results
<p>The electric vehicle supply equipment shall turn off the CP oscillator.</p> <p>After $t_{\text{shutdown}} = 40 \text{ ms}$ the Output current of the d.c. electric vehicle supply equipment ($I_{EVSE \text{ Output}}$) shall be $< 5 \text{ A}$.</p> <p>1.01 s after the occurrence of the fault the output voltage of the d.c. electric vehicle supply equipment ($V_{EVSE \text{ Output}}$) shall be $< 60 \text{ V}$.</p>

NOTE — It may be noted that the above sequence shall be followed by both the charging guns. There shall be a time difference of “t” s between SECC1 and SECC2 as specified by OEMs.

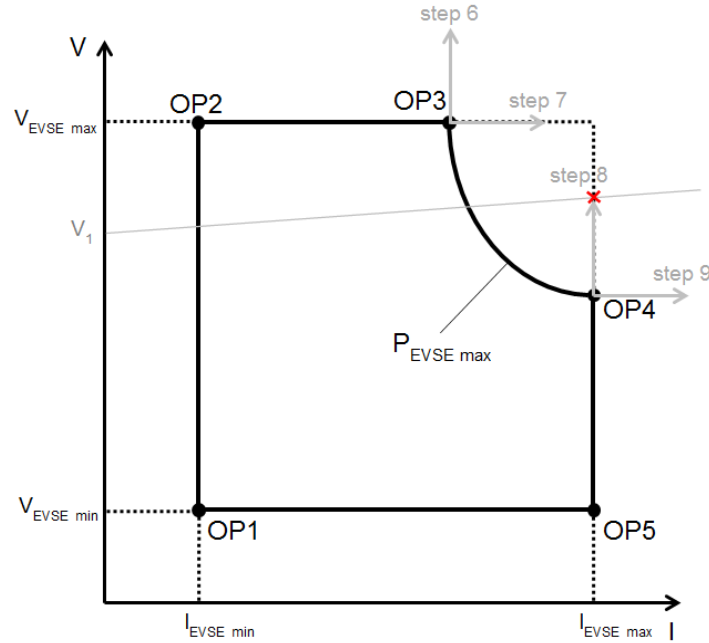

FIG. 32 TEST POINT GRID

Table 29 Compliance Test for Rated Outputs and Maximum Output Power

(Clause [A-9.3.5](#))

Matching to requirement (chapter)	101.2.1 Operating ranges for output voltage, output current, and output power
Short description	
<p>1. Test if the d.c. electric vehicle supply equipment does not exceed its maximum rated power, even if the maximum power request by the Electric Vehicle is beyond the rated maximum power of the d.c. electric vehicle supply equipment.</p> <p>2. Test if the d.c. electric vehicle supply equipment is able to deliver d.c. power in the voltage range [Vmin, Vmax] and the regulated current range [Imin, Imax] within the limit of its maximum rated power [Pmax] at the ambient temperature – 5 °C to 55 °C below 1 000 m above sea level.</p>	
Pre-conditions	
<p>The electric vehicle supply equipment has successfully transmitted its following properties to the EV-simulator:</p> <p>$V_{EVSE\ min}$, $V_{EVSE\ max}$, $I_{EVSE\ min}$, $I_{EVSE\ max}$, $P_{EVSE\ max}$</p> <p>The charging sequence shall be successfully done until $t=t8$ according to Fig. 21, including the message “PowerDeliveryReq” (according to IS/ISO 15118), with the following values used during pre-charging:</p> <p>$V1 = V_{EVSE\ min} - (R1 + R2) \times I_{EVSE\ min}$ if $V_{EVSE\ min} \geq (R1 + R2) \times I_{EVSE\ min}$</p> <p>and:</p> <p>$V1 = 0\ V$ if $V_{EVSE\ min} < (R1 + R2) \times I_{EVSE\ min}$</p>	

Table 29 (Continued)

<p>and the parameters “EVTargetVoltage” in message “PreChargeReq” (according to IS/ISO 15118):</p> $EV_{\text{TargetVoltage}} = V_{EV \text{ target}} = V_{EVSE \text{ min}}$
Test setup
<p>Standard test setup, additionally:</p> <p>To avoid dynamical influence by unknown inductances in the electric vehicle supply equipment, the test shall be executed in a stationary set point. Measure in this stationary phase for a duration of 3 s with a measurement rate of 100 ms or better.</p> <p>Stationary ambient temperature (as specified at 101.2.1):</p> <p>Case 1: Minimum ambient temperature as specified by manufacturer</p> <p>Case 2: - 5 °C</p> <p>Case 4: + 22 °C</p> <p>Case 3: + 55 °C</p> <p>Case 4: Maximum ambient temperature as specified by manufacturer</p>
Action(s)
<p>This test case shall be executed in single steps as indicated below.</p> <p>In each test step, the EV-simulator shall issue current/voltage requests (that is, “CurrentDemandReq” in case of PLC communication according to IS/ISO 15118) with the parameter as given in the list below according to the specifications of :</p> $EV_{\text{targetCurrent}} = I_{EV \text{ target}} ;$ $EV_{\text{targetVoltage}} = V_{EV \text{ target}}.$ <p>The evaluation of the expected results shall be done in steady state operation.</p> <p>The order of sequence of test points can be optimized for the used load. Delay times between the test points can be used, for example, for cooling down the load.</p> <p>For each step the following description uses indices m and n.</p> <p>m : The consecutive index is used to identify the value of the intended current respectively target current.</p> <p>n : This consecutive index is used to identify the value of the voltage V1, respectively intended voltage or target voltage.</p> <p>Main actions to be performed for all test points:</p> <ol style="list-style-type: none"> 1) Set V1 to the values as defined below. 2) For each test point TP request $I_{EV \text{ target}}$ and $V_{EV \text{ target}}$ with the values as defined below. 3) Wait T_{delay} (see definition below) in order to reach steady state operation before measuring. 4) Measure electric vehicle supply equipment output current $I_{EVSE \text{ Output } m,n}$ and output voltage $V_{EVSE \text{ Output } m,n}$. <p>Calculations:</p> <p>Determine active output power</p> $P_{EVSE \text{ Output } m,n} = I_{EVSE \text{ Output } m,n} \times V_{EVSE \text{ Output } m,n}$

Table 29 (Continued)

Definitions:

$T_{\text{delay}} = 2 \text{ s}$ for current steps of $< 20 \text{ A}$

$T_{\text{delay}} = 2 \text{ s} + 1.1 \times (| I_{\text{EVSE intended m,n}} - \text{previous } I_{\text{EVSE Output}} |) / 20 \text{ A/s}$ for current steps of $\geq 20 \text{ A}$

Target values requested to set test point $TP_{m, n}$:

Steps 1-9 shall be tested at each case listed above:

Step 1: (see OP5 in [Fig. 30](#))

$$I_{\text{EV target}} = I_{\text{EVSE max}}$$

$$V_{\text{EV target}} = V_{\text{EVSE min}}$$

Step 2: (see OP4 in [Fig. 30](#))

$$I_{\text{EV target}} = I_{\text{EVSE max}}$$

$$V_{\text{EV target}} = P_{\text{EVSE max}} / I_{\text{EVSE max}}$$

Step 3: (see OP3 in [Fig. 30](#))

$$I_{\text{EV target}} = P_{\text{EVSE max}} / V_{\text{EVSE max}}$$

$$V_{\text{EV target}} = V_{\text{EVSE max}}$$

Step 4: (see OP2 in [Fig. 30](#))

$$I_{\text{EV target}} = I_{\text{EVSE min}}$$

$$V_{\text{EV target}} = V_{\text{EVSE max}}$$

Step 5: (see OP1 in [Fig. 30](#))

$$I_{\text{EV target}} = I_{\text{EVSE min}}$$

$$V_{\text{EV target}} = V_{\text{EVSE min}}$$

Step 6:

$$I_{\text{EV target}} = P_{\text{EVSE max}} / V_{\text{EVSE max}}$$

$$V_{\text{EV target}} = V_{\text{EVSE max}}$$

Step 7:

$$I_{\text{EV target}} = 1.2 (P_{\text{EVSE max}} / V_{\text{EVSE max}})$$

$$V_{\text{EV target}} = V_{\text{EVSE max}}$$

Step 8:

$$I_{\text{EV target}} = 1.2 \times I_{\text{EVSE max}}$$

$$V_{\text{EV target}} = P_{\text{EVSE max}} / I_{\text{EVSE max}}$$

Table 29 (Concluded)

<p>Step 9:</p> $I_{EV \text{ target}} = I_{EVSE \text{ max}}$ $V_{EV \text{ target}} = 1.2 (P_{EVSE \text{ max}}/V_{EVSE_max})$ <p>Configuration of the test bench for all steps:</p> $V1 = V_{EV \text{ target}} - (R1 + R2) \times I_{EV \text{ target}}$ <p>with</p> $V1 \geq 0 \text{ V}$
Expected results
<p>All cases, all Steps:</p> <p>measured current and voltage values shall be positive (> 0) in steady state operation.</p> <p>This test case is passed if each of the following test criteria is fulfilled for all measurements in steady state operation:</p> <p>Step 1:</p> $V_{EVSE \text{ Output}} > 0$ <p>Steps 2-4:</p> $V_{EVSE \text{ Output}} > 0$ $I_{EVSE \text{ Output}} > 0$ <p>Step 5:</p> $V_{EVSE \text{ Output}} > 0$ <p>Steps 6-9:</p> <p>The d.c. electric vehicle supply equipment shall not exceed its maximum rated power and shall stop the charging process.</p>

Table 30 Compliance Test for Protection Against Overvoltage at the Battery(Clause [A-9.3.6](#))

Matching to requirement (chapter)	6.3.1.106 Protection against overvoltage at the interface 6.3.1.114 Shutdown of d.c. electric vehicle supply equipment
Short description	
Emergency shutdown in case of an overvoltage at the interface and disconnection of the d.c. electric vehicle supply equipment's supply.	
Pre-conditions	
<p>The d.c. electric vehicle supply equipment has successfully transmitted its following properties to the EV-simulator:</p> $V_{EVSE\ min}, V_{EVSE\ max}, I_{EVSE\ min}, I_{EVSE\ max}, P_{EVSE\ max}$ <p>The charging sequence shall be successfully done until $t = t_8$ according to Fig. 21, including the message "PowerDeliveryReq" (according to IS/ISO 15118), with the following values used during pre-charging:</p> $V_1 = V_{EVSE\ min} - (R_1 + R_2) \times I_{EVSE\ min} \quad \text{if} \quad V_{EVSE\ min} \geq (R_1 + R_2) \times I_{EVSE\ min}$ <p>and:</p> $V_1 = 0\ V \quad \text{if} \quad V_{EVSE\ min} < (R_1 + R_2) \times I_{EVSE\ min}$ <p>and the parameters "EVTargetVoltage" in message "PreChargeReq" (according to IS/ISO 15118):</p> $EVTargetVoltage = V_{EV\ target} = V_{EVSE\ min}$	
Test setup	
<p>Standard test setup.</p> <p>The maximum error shutdown time $t_{shutdown}$ is defined as follows:</p> $t_{shutdown} = 1.01\ s \quad (t_{trigger} = 10\ ms, t_{perform} = 1\ s)$	

Table 30 (Concluded)

Action(s)
<p>In each test step, the EV-simulator shall issue current requests and, if applicable voltage requests.</p> <p>The message “CurrentDemandReq” according to IS/ISO 15118 shall contain the following parameters:</p> <p>EV target current = $I_{EV\ target}$</p> <p>EV target voltage = $V_{EV\ target}$</p> <p>EV maximum voltage limit = $V_{EV\ max}$</p> <p>Definition of intended test point:</p> <p>$I_{EVSE\ intended} = I_{EVSE\ min}$</p> <p>$V_{EVSE\ intended} = V_{EVSE\ min} + (V_{EVSE\ max} - V_{EVSE\ min})/2$</p> <p>1) Set:</p> <p style="padding-left: 40px;">$V1 = V_{EVSE\ min}$</p> <p>2) Send:</p> <p style="padding-left: 40px;">$I_{EV\ target} = I_{EVSE\ min}$</p> <p style="padding-left: 40px;">$V_{EV\ target} = V_{EVSE\ min}$</p> <p style="padding-left: 40px;">$V_{EV\ max} = V_{EVSE\ min} + (V_{EVSE\ max} - V_{EVSE\ min})/2$</p> <p>3) Wait for T_{wait} (see definition below) in order to reach steady state operation</p> <p style="padding-left: 40px;">$T_{wait} = 2\ s$</p> <p>4) Set:</p> <p style="padding-left: 40px;">$V1 = V_{EV\ max} + 10\ V\ for\ 400\ ms$</p> <p style="padding-left: 40px;">NOTE — According to 6.3.1.106, the vehicle shall be able to change the maximum voltage limit during charging process.</p>
Expected results
<p>The electric vehicle supply equipment shall turn off the CP oscillator.</p> <p>After $t_{shutdown} = 1.01\ s$ the output current of the d.c. electric vehicle supply equipment (IEVSE output) shall be $< 5\ A$.</p>

Table 31 Compliance test for Emergency Shutdown in case of Control Pilot Disconnection

(Clause [A-9.3.7](#))

<p>Matching to requirement (chapter)</p>	<p>6.3.1.114 Shutdown of d.c. electric vehicle supply equipment A-4.3 CP lost shutdown</p>
<p>Short description</p>	
<p>Emergency shutdown in case of CP lost.</p>	
<p>Pre-conditions</p>	
<p>The d.c. electric vehicle supply equipment has successfully transmitted its following properties to the EV-simulator:</p> <p>$V_{EVSE\ min}$, $V_{EVSE\ max}$, $I_{EVSE\ min}$, $I_{EVSE\ max}$, $P_{EVSE\ max}$</p> <p>The charging sequence shall be successfully done until $t = t_8$ according to Fig. 21, including the message “PowerDeliveryReq” (according to IS/ISO 15118), with the following values used during pre-charging:</p> <p>$V_1 = V_{EVSE\ min} - (R_1 + R_2) \times I_{EVSE\ min}$ if $V_{EVSE\ min} \geq (R_1 + R_2) \times I_{EVSE\ min}$</p> <p>and:</p> <p>$V_1 = 0\ V$ if $V_{EVSE\ min} < (R_1 + R_2) \times I_{EVSE\ min}$</p> <p>and the parameters “EVTargetVoltage” in message “PreChargeReq” (according to IS/ISO 15118):</p> <p>EV target voltage = $V_{EV\ target} = V_{EVSE\ min}$</p>	
<p>Test setup</p>	
<p>Standard test setup with additional relay for opening CP:</p>	
<p>The maximum emergency shutdown time $t_{shutdown}$ is defined as follows:</p>	
<p>$t_{shutdown} = t_{trigger} + t_{perform} = 40\ ms$ after control pilot interruption</p>	
<p>with: $t_{trigger} = 10\ ms$</p>	
<p>$t_{perform} = 30\ ms$</p>	
<p>The de-energization time $t_{de-energization}$ is defined as follows:</p>	
<p>$t_{de-energization} = 100\ ms$ after control pilot interruption</p>	
<p>Action(s)</p>	
<p>In each test step, the EV-simulator shall issue current requests and, if applicable voltage requests.</p>	
<p>The message “CurrentDemandReq” according to IS/ISO 15118 shall contain the following parameters:</p>	
<p>EV target current = $I_{EV\ target}$</p>	
<p>EV target voltage = $V_{EV\ target}$</p>	

Table 31 (Concluded)

<p>Definition of intended test point (OP5):</p> $I_{EVSE\ intended} = I_{EVSE\ max}$ $V_{EVSE\ intended} = V_{EVSE\ min}$ <p>1) Set:</p> $V1 = V_{EVSE\ min} - (R1+R2) \times I_{EVSE\ max}$ <p>If $V_{EVSE\ min} - (R1+R2) \times I_{EVSE\ max} < 0$, then set $V1 = 0V$</p> <p>2) Send:</p> $I_{EV\ target} = I_{EVSE\ max}$ $V_{EV\ target} = \min (P_{EVSE\ max}/I_{EVSE\ max}; V_{EVSE\ max})$ <p>3) Wait for T_{wait} (see definition below) in order to reach steady state operation before measuring</p> $T_{wait} = 2\ s + 1.1 \times I_{EVSE\ max} / 20\ A/s$ <p>4) Interrupt control pilot inside EV-simulator.</p> <p>5) Initiate charging process after emergency shutdown has been performed.</p>
<p>Expected results</p>
<p>After $t_{shutdown} = 40\ ms$ the output current of the d.c. electric vehicle supply equipment ($I_{EVSE\ Output}$) shall be $< 5\ A$.</p> <p>1.01 s after the occurrence of the fault the output voltage of the d.c. electric vehicle supply equipment ($V_{EVSEOutput}$) shall be $< 60\ V$.</p> <p>After $t_{de-energization} = 100\ ms$ the output voltage of the d.c. electric vehicle supply equipment ($V_{EVSE\ Output}$) shall be $< 60\ V$.</p> <p>The d.c. electric vehicle supply equipment does not go into ready mode until the station is serviced.</p> <p>(The message “ChargeParameterDiscoveryRes” according to IS/ISO 15118 shall contain d.c._EVSEStatusCode \neq EVSE_Ready).</p>

Table 32 Compliance Test for Load Dump

(Clause [A-9.3.8](#))

Matching to requirement (chapter)	101.2.7 Load dump
Short description	
Check if d.c. electric vehicle supply equipment will limit the voltage overshoot to the specified values for each system in case of load dump.	
Pre-conditions	
<p>The electric vehicle supply equipment has successfully transmitted its following properties to the EV-simulator:</p> <p>$V_{EVSE\ min}$, $V_{EVSE\ max}$, $I_{EVSE\ min}$, $I_{EVSE\ max}$, $P_{EVSE\ max}$</p> <p>The charging sequence shall be successfully done until $t = t8$ according to Fig. 21, including the message “PowerDeliveryReq” (according to IS/ISO 15118), with the following values used during pre-charging:</p> <p>$V1 = V_{EVSE\ min} - (R1 + R2) \times I_{EVSE\ min}$ if $V_{EVSE\ min} \geq (R1 + R2) \times I_{EVSE\ min}$</p> <p>and:</p> <p>$V1 = 0\ V$ if $V_{EVSE\ min} < (R1 + R2) \times I_{EVSE\ min}$</p> <p>and the parameters “EVTargetVoltage” in message “PreChargeReq” (according to IS/ISO 15118):</p> <p>EV target voltage = $V_{EV\ target} = V_{EVSE\ min}$</p>	
Test setup	
Standard test setup	
Switch S3 closed	
Action(s)	
<p>The message “CurrentDemandReq” according to IS/ISO 15118 shall contain the following parameters:</p> <p>EV target current = $I_{EV\ target}$</p> <p>EV target voltage = $V_{EV\ target}$</p> <p>EV maximum voltage limit = $V_{EV\ max}$</p> <p>Definition of intended test point:</p> <p>$I_{EVSE\ intended} = I_{EVSE\ min}$</p> <p>$V_{EVSE\ intended} = 1.1 \times V_{EVSE\ min}$</p> <p>1) Set:</p> <p>$V1 = 1.1 \times V_{EVSE\ min} - (R1+R2) \times I_{EVSE\ max}$</p> <p>if $1.1 \times V_{EVSE\ min} - (R1+R2) \times I_{EVSE\ max} \geq 0\ V$</p> <p>2) Send:</p> <p>$I_{EV\ target} = I_{EVSE\ min}$</p> <p>$V_{EV\ target} = 1.1 \times V_{EVSE\ min}$</p> <p>$V_{EV\ max} = 1.2 \times V_{EVSE\ min}$</p> <p>3) Wait for T_{wait} (<i>see</i> definition below) in order to reach steady state operation</p>	

Table 32 (Concluded)

$T_{\text{wait}} = 2 \text{ s} + 1.1 \times I_{\text{EVSE max}} / 20 \text{ A/s}$ <p>Main action to be performed:</p> <p>Open S1 (see Fig. 17).</p>
Expected results
$V_{\text{EVSE Output}} \leq 1.1 \times V_{\text{EV max}}$ $dV_{\text{EVSE Output}} / dt \leq 250 \text{ V/ms}$

Table 33 Compliance test for Protection against Uncontrolled Reverse Power Flow from Vehicle

(Clause A-9.3.9)

Matching Requirement (Chapter)	101.1 Protection against uncontrolled reverse power flow from vehicle
Short description	
Test if electric vehicle supply equipment will prevent any reverse power flow from the vehicle.	
Pre-conditions	
<p>The charging sequence shall be successfully done until $t=t_8$ according to Fig. 21, including the message “PowerDeliveryReq” (according to IS/ISO 15118), with the following values used during pre-charging:</p> $V_1 = V_{\text{EVSE min}} - (R_1 + R_2) \times I_{\text{EVSE min}} \quad \text{if} \quad V_{\text{EVSE min}} \geq (R_1 + R_2) \times I_{\text{EVSE min}}$ <p>and:</p> $V_1 = 0 \text{ V} \quad \text{if} \quad V_{\text{EVSE min}} < (R_1 + R_2) \times I_{\text{EVSE min}}$ <p>and the parameters “EVTARGETVOLTAGE” in message “PreChargeReq” (according to IS/ISO 15118):</p> $\text{EVTARGETVOLTAGE} = V_{\text{EV target}} = V_{\text{EVSE min}}$ <p>The message “CurrentDemandReq” according to IS/ISO 15118 shall contain the following parameters:</p> $\text{EV target current} = I_{\text{EV target}}$ $\text{EV target voltage} = V_{\text{EV target}}$ $I_{\text{EV target}} = I_{\text{EVSE min}}$ $V_{\text{EV target}} = V_{\text{EVSE min}} + (V_{\text{EVSE max}} - V_{\text{EVSE min}}) / 2$ <p>Setting of the test bench:</p> $V_1 = V_{\text{EV target}} - (R_1 + R_2) \times I_{\text{EV target}}$	
Test setup	
Standard test setup	
Action(s)	
<p>The EV-simulator shall issue the identical values for current and, if applicable voltage requests as send in the pre-conditions.</p> <ol style="list-style-type: none"> 1. set $V_1 = V_{\text{EV target}} + 10 \text{ V}$ 2. wait 250 ms to start current measurement for $I_{\text{EVSE Output}}$ 	
Expected results	
$I_{\text{EVSE Output}} \geq 0$ for a duration of 3 s	

Table 34 Compliance Test for Limiting the Inrush Current by d.c. Electric Vehicle Supply Equipment to 2A
(Clause [A-9.3.10](#))

Matching (Chapter)	Requirement	B-6 Turn on inrush current
Short description		
Check if the d.c. electric vehicle supply equipment limits the inrush current to max. 2A in case of closing the electric vehicle disconnecting device after pre-charge sequence.		
Pre-conditions		
The electric vehicle supply equipment has successfully transmitted its following properties to the EV-simulator: $V_{EVSE\ min}$, $V_{EVSE\ max}$, $I_{EVSE\ min}$, $I_{EVSE\ max}$, $P_{EVSE\ max}$ The message “PrechargeReq” according to IS/ISO 15118 shall contain the following parameter: EV target tvoltage = $V_{EV\ target}$ with: $V_{EV\ target} = V_{EVSE\ max}$ Precharge sequence shall be successfully done until: $V_{EVSE\ Output} = [0.95 \times V_{EV\ target}, V_{EV\ target}]$		
Test setup		
Standard test setup		
Action(s)		
1. Set $V1 = V_{EVSE\ Output} - 20V$ 2. Close S0 3. Measure $I_{EVSE\ Output}$ 1ms after closing S0 until first Current Demand Res message.		
Expected results		
$0A \leq I_{EVSE\ Output} \leq 2\ A$		

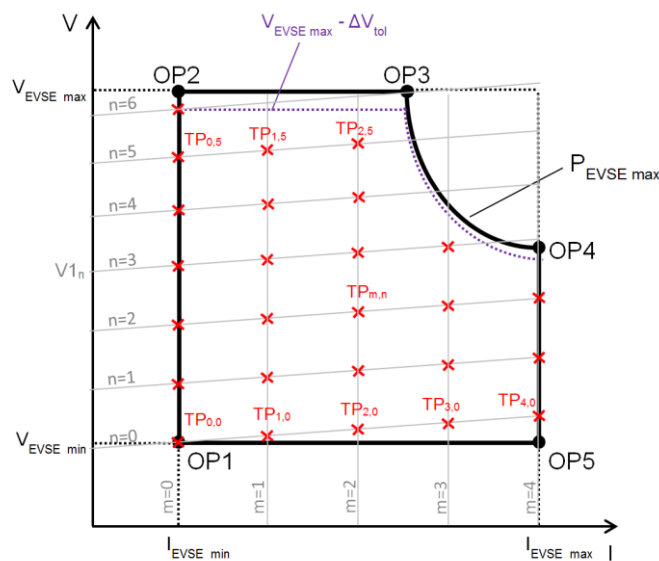

FIG. 33 TEST POINT GRID FOR OUTPUT CURRENT REGULATION IN CCC INCLUDING STATIC DEVIATION AND RIPPLE

A-9.3.11 Output Current Regulation in CCC including Static Deviation and Ripple

The compliance test is shown in [Fig. 33](#) and [Table 35](#).

[Figure 33](#) shows a simplified example of the test point grid with indices $m = 0 \dots 4$ and $n = 0 \dots 6$ in order to visualize the principal testing sequence of

this test case. However, the test point grid that shall actually be used for this test case shall cover indices $m = 0 \dots 20$ and $n = 0 \dots 20$, with some additional restrictions as described below.

The correlation between current and voltage is given by the following formula:

$$V_{EVSE, m, n} = V_{1n} + (R1 + R2) \times I_{EVSE, m, n}$$

Table 35 Compliance Test for Output Current Regulation in CCC (including static deviation and ripple) and Measurement Accuracy

(Clause [A-9.3.11](#))

Matching to requirement (chapter)	<p>101.2.1 Rated outputs and maximum output power</p> <p>101.2.2.1 Output current regulation in CCC</p> <p>101.2.5 Periodic and random deviation (current ripple)</p> <p>6.3.1.102 Measuring current and voltage</p>
Short description	
<p>Check if the current regulation fulfils the requirements for static, periodic and random deviation.</p> <p>Check accuracy of current measurement.</p>	
Pre-conditions	
<p>The electric vehicle supply equipment has successfully transmitted its following properties to the EV-simulator:</p> <p>$V_{EVSE\ min}, V_{EVSE\ max}, I_{EVSE\ min}, I_{EVSE\ max}, P_{EVSE\ max}$</p> <p>The charging sequence shall be successfully done including the message “PowerDeliveryReq” (according to IS/ISO 15118), with the following values used during pre-charging:</p> <p>$V1 = V_{EVSE\ min} - (R1 + R2) \times I_{EVSE\ min}$ if $V_{EVSE\ min} \geq (R1 + R2) \times I_{EVSE\ min}$</p> <p>and:</p> <p>$V1 = 0\ V$ if $V_{EVSE\ min} < (R1 + R2) \times I_{EVSE\ min}$</p> <p>and the parameter “EVTargetVoltage” in message “PreChargeReq” (according to IS/ISO 15118):</p> <p>EV target voltage = $V_{EV\ target} = V_{EVSE\ min}$</p>	
Test setup	
<p>Standard test setup, additionally:</p> <p>Measure in the stationary phase for a duration of 3 s.</p> <p>All measurements during this time shall be used for calculation and for expected results.</p>	
Action(s)	
<p>In the steps of this test case, certain properties of the EVSE are tested at specific test points in the operating range of the EVSE. The indices m and n are used as follows to refer to a specific test point TP_{m, n}:</p> <p>m: This consecutive index is used to identify the value of the intended current, or the target current, respectively.</p> <p>n: This consecutive index is used to identify the value of the voltage V1, or – together with index m – the intended voltage, respectively.</p> <p>The message “CurrentDemandReq” according to IS/ISO 15118 shall contain the following parameters:</p>	

Table 35 (Continued)

EV target current = $I_{EV \text{ target } m,n}$

EV target voltage = $V_{EV \text{ target } m,n}$

Definition of test point grid $TP_{m,n}$:

Indices range:

$m = 0 \dots 20, n = 0 \dots 20$

with:

$\Delta V_{tol} = 0.02 \times V_{EVSE \text{ max}} + 5 \text{ V}$ derived from [101.2.2.2](#) and [101.2.6](#)

NOTE: ΔV_{tol} is needed in order to achieve current regulation (CCC).

Test point $TP_{m,n} = (I_{EVSE \text{ intended } m,n} \mid V_{EVSE \text{ intended } m,n})$ with:

$$I_{EVSE \text{ intended } m,n} = I_{EVSE \text{ min}} + m/20 \times (I_{EVSE \text{ max}} - I_{EVSE \text{ min}}) \quad (1)$$

$$V_{EVSE \text{ intended } m,n} = V_{EVSE \text{ min}} + n/20 \times (V_{EVSE \text{ max}} - \Delta V_{tol} - V_{EVSE \text{ min}}) + (R1 + R2) \times (I_{EVSE \text{ intended } m,n} - I_{EVSE \text{ min}}) \quad (2)$$

$$V_{EVSE \text{ intended } m,n} + \Delta V_{tol} \leq V_{EVSE \text{ max}} \quad (3)$$

$$(V_{EVSE \text{ intended } m,n} + \Delta V_{tol}) \times I_{EVSE \text{ intended } m,n} \leq P_{EVSE \text{ max}} \quad (4)$$

All equations (1) to (4), where applicable, shall be fulfilled for each $TP_{m,n}$. If any of the equations (1) to (4) is not fulfilled for certain values of m and/or n , $(I_{EVSE \text{ intended } m,n} \mid V_{EVSE \text{ intended } m,n})$ is *not* a test point $TP_{m,n}$.

Target values requested to set test point $TP_{m,n}$:

$$I_{EV \text{ target } m,n} = I_{EVSE \text{ intended } m,n} \quad (5)$$

$$V_{EV \text{ target } m,n} = \min (P_{EVSE \text{ max}} / I_{EV \text{ target } m,n} ; V_{EVSE \text{ max}}) \quad (6)$$

Configuration of the test bench for test point $TP_{m,n}$:

$$V1_n = V_{EVSE \text{ min}} + n/20 \times (V_{EVSE \text{ max}} - \Delta V_{tol} - V_{EVSE \text{ min}}) - (R1 + R2) \times I_{EVSE \text{ min}} \quad (7)$$

with:

$$V1_n \geq 0 \text{ V} \quad (8)$$

If (7) results in $V1_n < 0 \text{ V}$, $V1_n$ shall be set to $V1_n = 0 \text{ V}$.

Calculations done continuously during for the measurement duration of each $TP_{m,n}$ (3 s):

Determine active output power:

$$P_{EVSE \text{ Output } m,n} = I_{EVSE \text{ Output } m,n} \times V_{EVSE \text{ Output } m,n} \quad (9)$$

Determine the absolute static current deviation value of the 0 Hz component (that is pure d.c.) of the output current $I_{EVSE \text{ Output } m,n}$:

$$I_{\text{dev abs } m,n} = \left| I_{EVSE \text{ Output } m,n} - I_{EV \text{ target } m,n} \right| \quad \text{for } I_{EV \text{ target } m,n} < 50\text{A} \quad (10)$$

Determine the relative static current deviation value of the 0 Hz component (that is pure d.c.) of the output current $I_{EVSE \text{ Output } m,n}$:

$$I_{\text{dev rel } m,n} = \left| I_{EVSE \text{ Output } m,n} - I_{EV \text{ target } m,n} \right| / I_{EV \text{ target } m,n} \quad \text{for } I_{EV \text{ target } m,n} \geq 50\text{A} \quad (11)$$

Determine the maximum amplitude value ($I_{\text{rip low } m,n}$) of all current ripple components of the output current $I_{EVSE \text{ Output } m,n}$ in the frequency band above 0 Hz and below 10 Hz

Determine the maximum amplitude value ($I_{\text{rip mid } m,n}$) of all current ripple components of the output current $I_{EVSE \text{ Output } m,n}$ in the frequency band above 0 Hz and below 5 kHz

Table 35 (Continued)

Determine the maximum amplitude value ($I_{\text{rip high } m,n}$) of all current ripple components of the output current $I_{\text{EVSE Output } m,n}$ in the frequency band above 0 Hz and below 150 kHz	
Determine the absolute static current deviation value of the value measured by the d.c. electric vehicle supply equipment and transmitted via digital communication from the 0 Hz component (that is, pure d.c.) of the output current $I_{\text{EVSE Output } m,n}$:	
$I_{\text{dev measure } m,n} = I_{\text{EVSE measure } m,n} - I_{\text{EVSE Output } m,n} $	(11a)
Determine necessary wait time:	
for $m = 0$:	
$T_{\text{wait}} = I_{\text{EVSE min}} / (20 \text{ A/s})$	for $I_{\text{EVSE min}} \geq 20 \text{ A}$
$T_{\text{wait}} = 1 \text{ s}$	for $I_{\text{EVSE min}} < 20 \text{ A}$
for $m > 0$:	
$T_{\text{wait}} = I_{\text{EV target } m, n} - I_{\text{EVSE Output } m-1, n} / (20 \text{ A/s})$	for $ I_{\text{EV target } m, n} - I_{\text{EVSE Output } m-1, n} \geq 20 \text{ A}$
$T_{\text{wait}} = 1 \text{ s}$	for $ I_{\text{EV target } m, n} - I_{\text{EVSE Output } m-1, n} < 20 \text{ A}$
Main actions to be performed:	
The test points $TP_{m, n}$ shall be covered in sequences generated by two tested loops. The outer loop shall cover the index range of index n ($n = 0 \dots 20$) and therefore step through the different values of the voltage $V1$. The inner loop shall cover the index range of index m ($m = 0 \dots 20$) and therefore step through the different values of the intended output current (“current-step-sequence”), taking into account the maximum output power of the d.c. electric vehicle supply equipment.	
All equations (1) to (4), where applicable, shall be fulfilled for each $TP_{m, n}$, so for some values of n , the index range of the inner loop might not reach all values of m .	
In each current-step-sequence, a series of current values (indicated by index m) for a constant value of $V1$, that is for a fixed value of index n , shall be used for the test.	
Within each current-step-sequence (for example, $m = 0 \dots 20, n = 0, TP_{0..mmax, 0}$), only the value of the current demand $I_{\text{EV target } m, n}$ shall be altered for the individual test points, the value of $V1$ shall remain constant (for example, for $n = 0$: $V1_0$ to be used for $TP_{0..20, 0}$). After each current-step-sequence (that is, after testing $TP_{20, n}$), the current demand $I_{\text{EV target } m,n}$ shall be set to 0 A and communicated to the Electric Vehicle supply equipment in order to stop the energy flow from the Electric Vehicle supply equipment. Then, index n shall be incremented by 1, that is $V1$ shall be adjusted to the voltage value of the following sequence (for example, for $n = 1$: $V1_1$ to be used for $TP_{0..20, 1}$) and then the following current-step-sequence shall be started (for example $m = 0 \dots 20, n = 1, TP_{0..20, 1}$).	
The following pseudo code structure shows the actions to be taken during the execution of this test case. Please refer to the equations above for information on the individual values.	
Set $n = 0$	
Start outer loop	
Set $V1_n$	
Set $m = 0$	
Start inner loop (current-step-sequences)	
Determine necessary wait time T_{wait}	
Request target values to set test point $TP_{m, n}$ by sending the message “CurrentDemandReq” according to IS/ISO 15118	
Wait for T_{wait}	
Measure $I_{\text{EVSE Output } m, n}$ and $V_{\text{EVSE Output } m,n}$	

Table 35 (Concluded)

Get $I_{EVSE\ measure\ m,n}$ from digital communication	
Perform calculations to be done for each test point $TP_{m,n}$	
Check if expected results are achieved	
Increment m by 1	
If $m \leq 20$ and equations (1) to (5) are fulfilled, jump to beginning of inner loop	
Request target value $I_{EV\ target} = 0\ A$ by sending the message “Current Demand Req”	
Wait for $1.1 \times I_{EVSE\ Output\ m-1,n} / (100\ A/s)$	
Increment n by 1	
If $n \leq 20$, jump to beginning of outer loop	
End test	
NOTE — The slew rate of 100 A/s was chosen based on “ 101.2.4 descending rate of charging current”. The factor 1.1 was chosen to provide an additional 10 percent margin.	
Expected results	
This test case is passed if each of the following test criteria is fulfilled for each tested $TP_{m,n}$:	
$V_{EVSE\ Output\ m,n} > 0$	(12)
$I_{EVSE\ Output\ m,n} > 0$	(13)
$P_{EVSE\ Output\ m,n} \leq P_{EVSE\ max}$	(14)
$I_{rip\ low\ m,n} \leq 0.75A$	(15)
$I_{rip\ mid\ m,n} \leq 3A$	(16)
$I_{rip\ high\ m,n} \leq 4.5A$	(17)
$I_{dev\ measure\ m,n} \leq \max(0.5A 0.015 \times I_{EVSE\ Output\ m,n})$	(17a)
For $I_{EVSE\ target\ m,n} \leq 50A$	
All calculated values for $I_{dev\ abs\ m,n} \leq 2.5A$	(18)
For $I_{EVSE\ target\ m,n} \geq 50A$	
$I_{dev\ rel\ m,n} \leq 0.05$	(19)

A-9.3.12 Output Voltage Regulation in CVC during Pre-Charging

The compliance test is shown in [Fig. 34](#) and [Table 36](#).

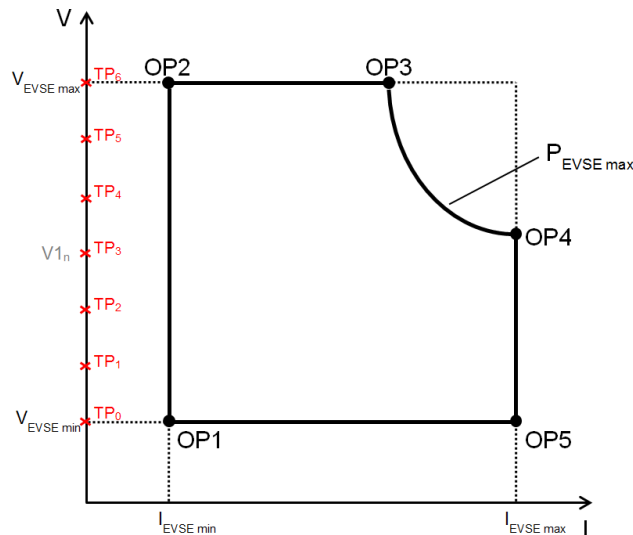

FIG. 34 TEST POINT GRID FOR OUTPUT VOLTAGE REGULATION IN CVC DURING PRE-CHARGING

Figure 34 shows a simplified example of the test point grid with indices $n = 0 \dots 6$ in order to visualize the principal testing sequence of this test case. However, the test point sequence that shall actually be used for this test case shall cover indices $n = 0 \dots 20$, with some additional restrictions as described below.

Table 36 Compliance Test for Output Voltage Regulation in CVC During Pre-Charging and Measurement Accuracy

(Clause [A-9.3.12](#))

Matching to requirement (chapter)	<p>101.2.2.2 Output voltage regulation in CVC</p> <p>101.2.6 Periodic and random deviation</p> <p>6.3.1.102 Measuring current and voltage</p>
Short description	
<p>Check if static voltage regulation during pre-charging fulfills the tolerance requirements.</p> <p>Check accuracy of voltage measurement.</p>	
Pre-conditions	
<p>The electric vehicle supply equipment has successfully transmitted its following properties to the electric vehicle: $V_{EVSE\ min}$, $V_{EVSE\ max}$, $I_{EVSE\ min}$, $I_{EVSE\ max}$, $P_{EVSE\ max}$</p> <p>The charging sequence shall be successfully done until $t = t_6$ according to Fig. 21.</p>	
Test setup	
<p>Standard test setup, but S0 is open, additionally:</p> <p>Measure in the stationary phase for a duration of 3 s.</p>	
Action(s)	
<p>In each test step, the EV-simulator shall issue current/voltage requests.</p> <p>The message “Current Demand Req” according to IS/ISO 15118 shall contain the following parameters:</p> <p>$EVtargetcurrent = I_{EV\ target}$</p> <p>$EVtargetvoltage = V_{EV\ target}$</p>	

Table 36 (Continued)

For each step the following description uses index n.

n: This consecutive index is used to identify the value of the voltage V1, respectively intended voltage or target voltage.

Definition of test point grid TP_n:

$$n = 0 \dots 20$$

TP_n = (I_{EVSE intended} | V_{EVSE intended m, n}) with

$$I_{EVSE\ intended} = 0\ A \quad (1)$$

$$V_{EVSE\ intended, n} = V_{EVSE\ min} + n/20 \times (V_{EVSE\ max} - V_{EVSE\ min}) \quad (2)$$

Calculations:

Determine active output power

$$P_{EVSE\ Output\ n} = I_{EVSE\ Output\ n} \times V_{EVSE\ Output\ n} \quad (3)$$

Determine the absolute static deviation

$$V_{dev\ abs\ n} = |V_{EVSE\ Output\ n} - V_{EV\ target\ n}| \quad (4)$$

Determine the relative static voltage deviation

$$V_{dev\ rel\ n} = |V_{EVSE\ Output\ n} - V_{EV\ target\ n}| / V_{EV\ target\ n} \quad (5)$$

Determine the peak voltage ripple V_{rip n} up to a frequency of 150 kHz (see Fig. 10)

$$V_{rip\ n} = \text{peak value of } (V_{EVSE\ Output\ rip\ n} - V_{EVSE\ Output\ n}) \quad (6)$$

Determine the absolute static voltage deviation value of the value measured by the d.c. electric vehicle supply equipment and transmitted via digital communication from the 0 Hz component (that is, pure d.c.) of the output voltage V_{EVSE Output n}:

$$V_{dev\ measure\ n} = |V_{EVSE\ measure\ n} - V_{EVSE\ Output\ n}| \quad (6a)$$

Definitions:

$$T_{wait} = 7\ s$$

NOTE — According to A-2, the charge control communication shall comply with IS/ISO 15118, which specifies a pre-charge timeout of 7 s.

Main actions to be performed:

For each test point TP_n request I_{EV target n} and V_{EV target n} with the values as defined below.

Wait for T_{wait} (see definition above) in order to reach steady state operation before measuring.

Measure Electric Vehicle supply equipment output current I_{EVSE Output n} and output voltage V_{EVSE Output m, n}.

Get V_{EVSE measure m, n} from digital communication

Target values requested to set test point TP_n:

$$V_{EV\ target\ n} = V_{EVSE\ intended\ n} \quad (7)$$

$$I_{EV\ target\ m, n} = 0\ A \quad (8)$$

Configuration of the EV-simulator for test point TP_n :

$$V1_n = V_{EVSE\ min} + n/20 \times (V_{EVSE\ max} - \Delta V_{tol} - V_{EVSE\ min}) - (R1 + R2) \times I_{EVSE\ min} \quad (9)$$

with:

$$V1_n \geq 0\ V \quad (10)$$

Table 36 (Concluded)

NOTE — If (9) results in $V_{1n} < 0$ V, V_{1n} shall be set to $V_{1n} = 0$ V.	
Expected results	
This test case is passed if each of the following test criteria is fulfilled for each TP _n :	
$V_{EVSE\ Output\ n} > 0$	(11)
$I_{EVSE\ Output\ n} = 0$	(12)
$ V_{EVSE\ Output\ n} - V_{EV\ target\ n} / V_{EV\ target\ n} \leq 0.05$	(13)
$ V_{EVSE\ Output\ n} - V_{EV\ target\ n} \leq 0.02 \times V_{EVSE\ max}$	(14)
$V_{rip\ n} \leq 5$ V	(15)
$V_{dev\ measure\ n} \leq 10$ V	(16)

A-9.3.13 Control Delay of Charging Current in CCC

The compliance test is shown in [Fig. 35](#) and [Table 37](#).

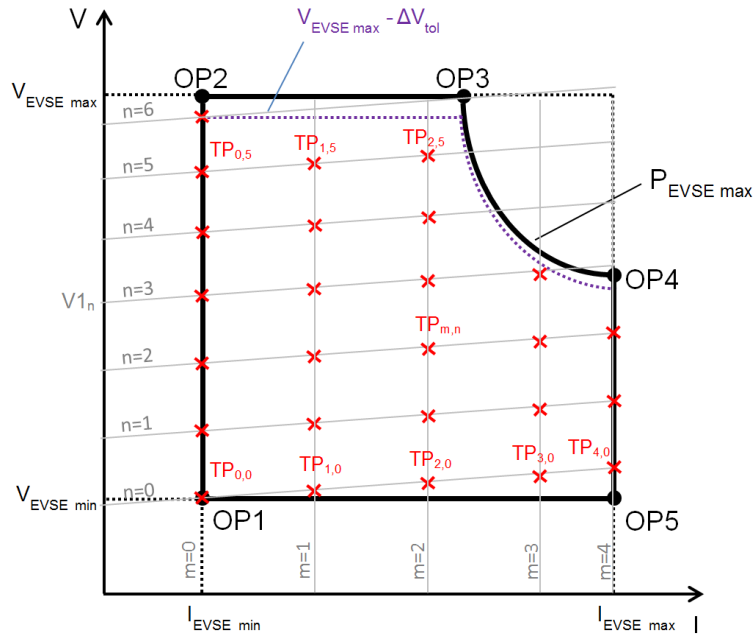

FIG. 35 TEST POINT GRID FOR CONTROL DELAY OF CHARGING CURRENT IN CCC

[Figure 35](#) shows a simplified example of the test point grid with indices $m = 0 \dots 4$ and $n = 0 \dots 6$ in order to visualize the principal testing sequence of this test case. However, the test point grid that shall actually be used for this test case shall cover indices $m = 0 \dots 20$ and $n = 0 \dots 20$, with some additional

restrictions as described below.

The correlation between current and voltage is given by the following formula:

$$V_{EVSE, m, n} = V_{1n} + (R1 + R2) \times I_{EVSE, m, n}$$

Table 37 Compliance Test for Control Delay of Charging Current in CCC

(Clause [A-9.3.13](#))

Matching to requirement (chapter)	101.2.3 Control delay of charging current in CCC
Short description	
Check the control delay of the charging current in CCC for the largest possible change of the requested current.	
Pre-conditions	
The electric vehicle supply equipment has successfully transmitted its following properties to the EV-simulator: $V_{EVSE\ min}$, $V_{EVSE\ max}$, $I_{EVSE\ min}$, $I_{EVSE\ max}$, $P_{EVSE\ max}$ The charging sequence shall be successfully done including the message “PowerDeliveryReq” (according to IS/ISO 15118), with the following values used during pre-charging: $V1 = V_{EVSE\ min} - (R1 + R2) \times I_{EVSE\ min}$ if $V_{EVSE\ min} \geq (R1 + R2) \times I_{EVSE\ min}$ and: $V1 = 0\ V$ if $V_{EVSE\ min} < (R1 + R2) \times I_{EVSE\ min}$ and the parameters “EVTARGETVoltage” in message “PreChargeReq” (according to IS/ISO 15118): $EVTARGETVoltage = V_{EV\ target} = V_{EVSE\ min}$	

Table 37 (Continued)

Test setup
<p>Standard test setup for d.c. charging EV-simulator, additionally:</p> <p>Determine the 0 Hz (that is, pure d.c.) component of the EV supply equipment output current $I_{EVSE\ Output\ m,\ n}$ at the point in time defined in the respective test step.</p>
Action(s)
<p>In the steps of this test case, certain properties of the electric vehicle supply equipment are tested at specific test points in the operating range of the electric vehicle supply equipment. The indices m and n are used as follows to refer to a specific test point $TP_{m,\ n}$:</p> <p>m: This consecutive index is used to identify the value of the intended current, or the target current, respectively.</p> <p>n: This consecutive index is used to identify the value of the voltage V_1, or – together with index m – the intended voltage, respectively.</p> <p>The message “CurrentDemandReq” according to IS/ISO 15118 shall contain the following parameters:</p> <p>EV target current = $I_{EV\ target\ m,\ n}$</p> <p>EV target voltage = $V_{EV\ target\ m,\ n}$</p> <p>Definition of test point grid $TP_{m,\ n}$:</p> <p>Indices range:</p> <p>$m = 0 \dots 2, n = 0 \dots 20$</p> <p>with:</p> <p>$\Delta V_{tol} = 0.02 \times V_{EVSE\ max} + 5\ V$ derived from 101.2.2.2 and 101.2.6</p> <p>NOTE — ΔV_{tol} is needed in order to achieve current regulation (CCC).</p> <p>Test point $TP_{m,\ n} = (I_{EVSE\ intended\ m,\ n} \mid V_{EVSE\ intended\ m,\ n})$ with:</p> $I_{EVSE\ intended\ 0,\ n} = I_{EVSE\ min} \text{ for } m = 0 \tag{1}$ $I_{EVSE\ intended\ 1,\ n} = \min(I_{EVSE\ max}; I_{EVSE\ Pmax\ n}) \text{ for } m = 1 \tag{2}$ $I_{EVSE\ intended\ 2,\ n} = I_{EVSE\ min} \text{ for } m = 2 \tag{3}$ $V_{EVSE\ intended\ m,\ n} = V_{EVSE\ min} + n/20 \times (V_{EVSE\ max} - \Delta V_{tol} - V_{EVSE\ min}) + (R1 + R2) \times (I_{EVSE\ intended\ m,\ n} - I_{EVSE\ min}) \tag{4}$ $V_{EVSE\ intended\ m,\ n} + \Delta V_{tol} \leq V_{EVSE\ max} \tag{5}$ $(V_{EVSE\ intended\ m,\ n} + \Delta V_{tol}) \times I_{EVSE\ intended\ m,\ n} \leq P_{EVSE\ max} \tag{6}$ <p>For $m = 1$, $I_{EVSE\ intended\ 1,\ n} = I_{EVSE\ max}$ shall be used for all $n = 0 \dots n'$ as long as (4), (5), and (6) are fulfilled.</p> <p>For $m = 1$ and $n = n'+1 \dots 20$, $I_{EVSE\ intended\ 1,\ n} = I_{EVSE\ Pmax\ n}$ shall be used and $I_{EVSE\ Pmax\ n}$ shall be selected as large as possible such that (4), (5), and (6) are fulfilled, that is in particular:</p> $(V_{EVSE\ intended\ 1,\ n} + \Delta V_{tol}) \times I_{EVSE\ Pmax\ n} = P_{EVSE\ max} \tag{7}$ <p>All equations (1) to (6), where applicable, shall be fulfilled for each $TP_{m,\ n}$. If any of the equations (1) to (6) is not fulfilled for certain values of m and/or n, $(I_{EVSE\ intended\ m,\ n} \mid V_{EVSE\ intended\ m,\ n})$ is not a test point $TP_{m,\ n}$.</p> <p>Target values requested to set test point $TP_{m,\ n}$:</p> $I_{EV\ target\ m,\ n} = I_{EVSE\ intended\ m,\ n} \tag{8}$ $V_{EV\ target\ m,\ n} = \min(P_{EVSE\ max} / I_{EV\ target\ m,\ n}; V_{EVSE\ max}) \tag{9}$

Table 37 (Continued)

Configuration of the test bench for test point TP _{m, n} :	
$V1_n = V_{EVSE\ min} + n/20 \times (V_{EVSE\ max} - \Delta V_{tol} - V_{EVSE\ min}) - (R1 + R2) \times I_{EVSE\ min}$	(10)
with:	
$V1_n \geq 0\ V$	(11)
If (10) results in $V1_n < 0\ V$, $V1_n$ shall be set to $V1_n = 0\ V$	
Calculations to be done for test point TP _{m, n} :	
Determine active output power:	
$P_{EVSE\ Output\ m, n} = I_{EVSE\ Output\ m, n} \times V_{EVSE\ Output\ m, n}$	
Determine absolute static current deviation of 0 Hz (that is, pure d.c.) component:	
$I_{dev\ abs\ m, n} = I_{EVSE\ Output\ m, n} - I_{EV\ target\ m, n} $ for $I_{EV\ target\ m, n} < 50\ A$	
Determine relative static current deviation of 0 Hz (that is, pure d.c.) component:	
$I_{dev\ rel\ m, n} = I_{EVSE\ Output\ m, n} - I_{EV\ target\ m, n} / I_{EV\ target\ m, n}$ for $I_{EV\ target\ m, n} \geq 50\ A$	
Determine necessary wait time:	
for $m = 0$:	
$T_{wait} = I_{EVSE\ min} / (20\ A/s)$ for $I_{EVSE\ min} \geq 20\ A$	
$T_{wait} = 1\ s$ for $I_{EVSE\ min} < 20\ A$	
for $m > 0$:	
$T_{wait} = I_{EV\ target\ m, n} - I_{EVSE\ Output\ m-1, n} / (20\ A/s)$ for $ I_{EV\ target\ m, n} - I_{EVSE\ Output\ m-1, n} \geq 20\ A$	
$T_{wait} = 1\ s$ for $ I_{EV\ target\ m, n} - I_{EVSE\ Output\ m-1, n} < 20\ A$	
Main actions to be performed:	
In this test case, the electric vehicle supply equipment shall be tested at each test point TP _{m, n} with $m > 0$. The test points TP _{0, n} (that is $m = 0$) are only needed as starting points for the current change. The test points TP _{m, n} shall be covered in sequences generated by two nested loops. The outer loop shall cover the index range of index n ($n = 0 \dots 20$) and therefore step through the different values of the voltage $V1$. The inner loop shall cover the index range of index m ($m = 0..2$) and therefore alternate between the minimum and the maximum value of the intended output current (“current-step-sequence”), taking into account the maximum output power of the electric vehicle supply equipment. (All equations (1) to (6), where applicable, shall be fulfilled for each TP _{m, n} .)	
In each current-step-sequence, a series of current values (indicated by index m) for a constant value of $V1$, that is for a fixed value of index n , shall be used for the test.	
Within each current-step-sequence (for example, $m = 0..2, n = 0, TP_{0..2, 0}$), only the value of the current demand $I_{EV\ target\ m, n}$ shall be altered for the individual test points, the value of $V1$ shall remain constant (for example for $n = 0$: $V1_0$ to be used for $TP_{0..2, 0}$). After each current-step-sequence (that is, after testing $TP_{2, n}$), the current demand $I_{EV\ target}$ shall be set to 0 A and communicated to the electric vehicle supply equipment in order to stop the energy flow from the electric vehicle supply equipment. Then, index n shall be incremented by 1, that is $V1$ shall be adjusted to the voltage value of the following sequence (for example, for $n = 1$: $V1_1$ to be used for $TP_{0..2, 1}$) and then the following current-step-sequence shall be started (for example, $m = 0..2, n = 1, TP_{0..2, 1}$).	
The following pseudo code structure shows the actions to be taken during the execution of this test case. Please refer to the equations above for information on the individual values.	
Set $n = 0$	
Start outer loop	

Table 37 (Concluded)

<p>Set $V_{1,n}$</p> <p>Set $m = 0$</p> <p>Start inner loop (current-step-sequences)</p> <p>Determine necessary wait time T_{wait}</p> <p>Request target values to set test point $TP_{m,n}$ by sending the message “CurrentDemandReq” according to IS/ISO 15118</p> <p>Wait for T_{wait}</p> <p>Measure $I_{EVSE Output m,n}$ and $V_{EVSE Output m,n}$</p> <p>If $m > 0$ Then</p> <p>Perform calculations to be done for each test point $TP_{m,n}$</p> <p>Check if expected results are achieved</p> <p>End if</p> <p>Increment m by 1</p> <p>If $m \leq 2$ and (5) is fulfilled, jump to beginning of inner loop</p> <p>Request target value $I_{EV target} = 0$ A by sending the message “CurrentDemandReq”</p> <p>Wait for $1.1 \times I_{EVSE Output m-1,n} / (100 \text{ A/s})$</p> <p>Increment n by 1</p> <p>If $n \leq 20$, jump to beginning of outer loop</p> <p>End test</p> <p>NOTE — The slew rate of 100 A/s was chosen based on “101.2.4 descending rate of charging current”. The factor 1.1 was chosen to provide an additional 10 percent margin.</p>	
Expected results	
This test case is passed if each of the following test criteria is fulfilled for each $TP_{m,n}$:	
$V_{EVSE Output m,n} > 0$	(12)
$I_{EVSE Output m,n} > 0$	(13)
$P_{EVSE Output m,n} \leq P_{EVSE max}$	(14)
For $I_{EV target m,n} < 50$ A:	
$I_{dev abs m,n} \leq 2.5$ A	(15)
For $I_{EV target m,n} \geq 50$ A:	
$I_{dev rel m,n} \leq 0.05$	(16)

A-9.3.14 Descending Rate of Charging Current

The compliance test is shown in [Fig. 36](#) and [Table 38](#).

Table 38 Compliance Test for Descending Rate of Charging Current(Clause [A-9.3.14](#))

Matching to requirement (chapter)	101.2.4 Descending rate of charging current
Short description	
Check the descending rate of the charging current in CCC.	
Pre-conditions	
<p>The d.c. electric vehicle supply equipment has successfully transmitted its following properties to the EV-simulator:</p> <p>$V_{EVSE\ min}$, $V_{EVSE\ max}$, $I_{EVSE\ min}$, $I_{EVSE\ max}$, $P_{EVSE\ max}$</p> <p>The charging sequence shall be successfully done until $t = t_9$ according to Fig. 21, including the message “PowerDeliveryReq” (according to IS/ISO 15118), with the following values used during pre-charging:</p> $V_1 = V_{EVSE\ min} - (R_1 + R_2) \times I_{EVSE\ min} \quad \text{if} \quad V_{EVSE\ min} \geq (R_1 + R_2) \times I_{EVSE\ min}$ <p>and:</p> $V_1 = 0\ V \quad \text{if} \quad V_{EVSE\ min} < (R_1 + R_2) \times I_{EVSE\ min}$ <p>and the parameters “EVTargetVoltage” in message “PreChargeReq” (according to IS/ISO 15118):</p> $Ev\ target\ voltage = V_{EV\ target} = V_{EVSE\ min}$	
Test setup	
Standard test setup	
Action(s)	
<p>In each test step, the EV-simulator shall issue current requests and, if applicable voltage requests.</p> <p>The message “Current Demand Req” according to IS/ISO 15118 shall contain the following parameters:</p> $EVTargetCurrent = I_{EV\ target\ m,\ n}$ $EVTargetVoltage = V_{EV\ target\ m,\ n}$ <p>1) Set:</p> $V_{1n} = V_{EV\ target\ m,\ n} - (R_1 + R_2) \times I_{EVSE\ min}$ <p>if $V_{EV\ target\ m,\ n} - (R_1 + R_2) \times I_{EVSE\ min} \geq 0$</p> <p>2) Send (message Current Demand Req according to IS/ISO 15118): :</p> $I_{EV\ target\ m,\ n} = I_{EVSE\ max}$ $V_{EV\ target\ m,\ n} = \min (P_{EVSE\ max} / I_{EV\ target\ m,\ n} ; V_{EVSE\ max}) - \Delta V_{tol}$ <p>3) Wait for T_{wait} (<i>see</i> definition below) in order to reach steady state operation</p> $T_{wait} = 2\ s + 1.1 \times I_{EVSE\ max} / 20\ A/s$ <p>4) Measure $I_{EVSE\ Output}$, store value as “$I_{EVSE\ Output,\ i}$”</p> <p>5) Send $I_{EV\ target\ m,\ n} = I_{EVSE\ min}$ and start timer (timestamp t_1)</p> <p>6) If $I_{EVSE\ Output} \leq I_{EVSE\ min} + \Delta I_{tol}$:</p>	

Table 38 (Concluded)

Measure $I_{EVSE\ Output}$, store value as “ $I_{EVSE\ Output,2}$ ” and stop timer (timestamp t_2)
Expected results
This test case is passed if the following test criteria is fulfilled: $((I_{EVSE\ Output, 1} - I_{EVSE\ Output, 2}) / (100\ A/s)) \geq (t_2 - t_1)$, with $(t_2 - t_1)$ = time elapsed between start and stop of the timer.

NOTE — It may be noted that the above sequence shall be followed by both the charging guns. There shall be a time difference of “t” sec between SECC1 and SECC2 as specified by OEMs.

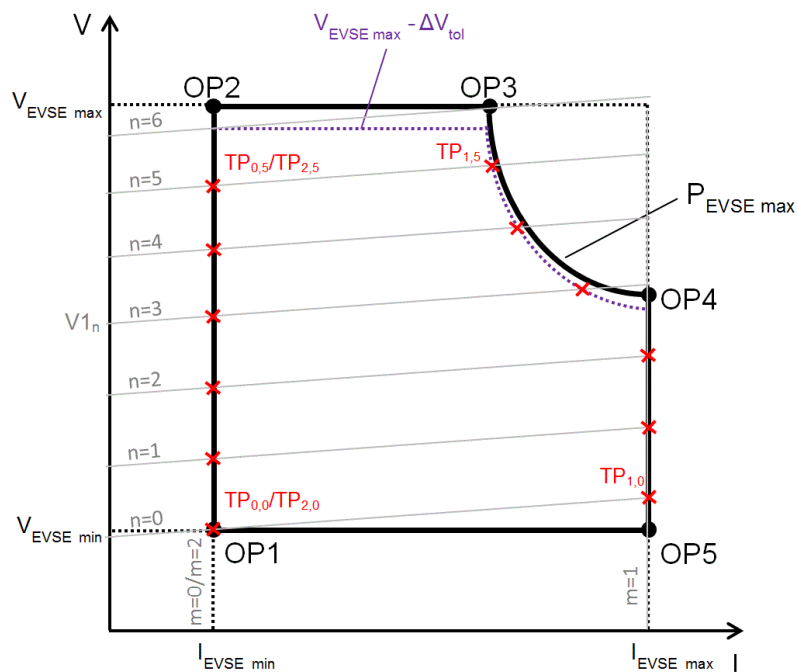

FIG. 36 TEST POINT GRID FOR DESCENDING RATE OF CHARGING CURRENT

Figure 36 shows a simplified example of the test point grid with indices $m = 0 \dots 2$ and $n = 0 \dots 6$ in order to visualize the principal testing sequence of this test case. However, the test point grid that shall actually be used for this test case shall cover indices $m = 0 \dots 2$ and $n = 0 \dots 20$, with some additional restrictions as described below.

The correlation between current and voltage is given

by the following formula:

$$V_{EVSE\ m, n} = V1_n + (R1 + R2) \times I_{EVSE\ m, n}$$

A-9.3.15 Insulation Checks

A-9.3.15.1 Insulation checks before pre-charge (cable check)

The compliance test is shown in Table 39.

Table 39 Compliance Test for Insulation Check to Detect Low Insulation Resistance before Pre-Charge
(Clause A-9.3.15.1)

Matching to requirement (chapter)	A-4.1.3 Cable check
Short description	
Reaction on low insulation resistance condition	
Pre-conditions	
Insulation monitoring device according A-4.1 IT (isolated terra) system requirements	
Test setup	
<p>1. Symmetrical test: Two test resistors with each $R = 99.5 \text{ k}\Omega$</p> <p>2. Asymmetrical test for failure between d.c. + and PE: Test resistor $R = 99.5 \text{ k}\Omega$</p> <p>3. Asymmetrical test for failure between d.c. - and PE: Test resistor $R = 99.5 \text{ k}\Omega$</p> <p>NOTE — The requirement requests an insulation resistance of $\geq 100 \text{ k}\Omega$. Therefore the injected fault condition should be close to the limit ($\rightarrow 99.5 \text{ k}\Omega$).</p>	
Action(s)	
<p>This test case shall be executed in single steps as indicated below:</p> <p>1a) Connect test resistors between d.c. + and PE as well as d.c. - and PE</p> <p>1b) The charging sequence shall be done until $t = t_4$ (according to Fig. 21)</p> <p>1c) The EV-simulator shall issue a pre-charge request (that is, “PrechargeReq” according to IS/ISO 15118) with EV target voltage = $V_{EV \text{ target}} = V_{EVSE \text{ min}}$.</p> <p>2a) Connect test resistor between d.c.+ and PE</p> <p>2b) The charging sequence shall be done until $t = t_4$ (according to Fig. 21)</p> <p>2c) The EV-simulator shall issue a pre-charge request (that is “PrechargeReq” according to IS/ISO 15118) with EV target voltage = $V_{EV \text{ target}} = V_{EVSE \text{ min}}$.</p> <p>3a) Connect test resistor between d.c. - and PE</p> <p>3b) The charging sequence shall be done until $t = t_4$ (according to Fig. 21)</p> <p>3c) The EV-simulator shall issue a pre-charge request (that is, “PrechargeReq” according to IS/ISO 15118) with EVTargetVoltage = $V_{EV \text{ target}} = V_{EVSE \text{ min}}$.</p>	
Expected results	
<p>At $t = t_4$ according to Fig. 21 (reception of CableCheckRes with parameter EVSEProcessing equal to "Finished"): The EVSE shall have turned off the CP oscillator. $V_{EVSE \text{ Output}}$ shall be $\leq 60 \text{ V}$ at $t = t_4$ (according to Fig. 21) + 1 s</p>	

NOTE — It may be noted that the above sequence shall be followed by both the charging guns. There shall be a time difference of “t” s between SECC1 and SECC2 as specified by OEMs.

A-9.3.15.2 Insulation check to detect fault state

The compliance test is shown in [Table 40](#) and [Table 41](#).

Table 40 Compliance Test for Insulation Check to Detect Fault State during Charging(Clause [A-9.3.15.2](#))

Matching to requirement (chapter)	A-4.1.4 Insulation monitoring during charging
Short description	
Reaction on low insulation resistance condition ($R \leq 100 \Omega/V$) during current demand phase	
Pre-conditions	
<p>The EVSE has successfully transmitted its following properties to the EV-simulator: $V_{EVSE \min}$, $V_{EVSE \max}$, $I_{EVSE \min}$, $I_{EVSE \max}$, $P_{EVSE \max}$</p> <p>The charging sequence shall be successfully done until $t=t_8$ according to Fig. 21, including the message “PowerDeliveryReq” (according to IS/ISO 15118), with the following values used during pre-charging:</p> $V1 = V_{EVSE \min} - (R1 + R2) \times I_{EVSE \min} \quad \text{if } V_{EVSE \min} \geq (R1 + R2) \times I_{EVSE \min}$ <p>and:</p> $V1 = 0 \text{ V} \quad \text{if } V_{EVSE \min} < (R1 + R2) \times I_{EVSE \min}$ <p>and the parameters “EVTARGETVOLTAGE” in message “PreChargeReq” (according to IS/ISO 15118):</p> <p>EV target voltage = $V_{EV \text{ target}} = V_{EVSE \min}$</p> <p>Insulation monitoring device according A-4.1 IT (isolated terra) system requirements</p>	
Test setup	
<p>Standard test setup</p> <p>1) Configuration for symmetrical test:</p> <p>Two test resistors with each $R = 99.5 \text{ k}\Omega$</p> <p>2) Configuration for 1st asymmetrical test for fault between d.c. + and PE:</p> <p>Test resistor $R = 99.5 \text{ k}\Omega$</p> <p>3) Configuration for 2nd asymmetrical test for fault between d.c. - and PE:</p> <p>Test resistor $R = 99.5 \text{ k}\Omega$</p> <p>NOTE — The requirement requests an insulation resistance of $\geq 100 \text{ k}\Omega$. Therefore, the injected fault condition should be close to the limit ($\rightarrow 99.5 \text{ k}\Omega$).</p>	
Action(s)	
<p>The complete sequence of test steps shall be executed with all three resistor configurations as described in the test setup (symmetrical and asymmetrical).</p> <p>The message “CurrentDemandReq” according to IS/ISO 15118 shall contain the following parameters:</p> <p>EV target current = $I_{EV \text{ target}}$</p> <p>EV target voltage = $V_{EV \text{ target}}$</p> <p>Definition of intended test point (OP5):</p> $I_{EVSE \text{ intended}} = I_{EVSE \max}$ $V_{EVSE \text{ intended}} = V_{EVSE \min}$ <p>1) Set</p> $V1 = V_{EVSE \min} - (R1+R2) \times I_{EVSE \max}$	

Table 41 (Concluded)

<p>Test resistor $R = 99 \Omega/V \times V_{EVSE \max}$</p> <p>3. Configuration for 2nd asymmetrical test for fault between d.c.- and PE:</p> <p>Test resistor $R = 99 \Omega/V \times V_{EVSE \max}$</p> <p>NOTE — The requirement requests an insulation resistance of $\geq 100 \Omega/V$. Therefore the injected fault condition should be close to the limit ($\rightarrow 99 \Omega/V$).</p>
Action(s)
<p>The complete sequence of test steps shall be executed with all three resistor configurations as described in the test setup (symmetrical and asymmetrical).</p> <p>The message “CurrentDemandReq” according to IS/ISO 15118 shall contain the following parameters:</p> <p>$EV_{targetCurrent} = I_{EV \ target}$</p> <p>$EV_{targetVoltage} = V_{EV \ target}$</p> <p>Definition of intended test point (OP5):</p> <p>$I_{EVSE \ intended} = I_{EVSE \ max}$</p> <p>$V_{EVSE \ intended} = V_{EVSE \ min}$</p> <ol style="list-style-type: none"> 1) Set $V1 = V_{EVSE \ min} - (R1+R2) \times I_{EVSEmax}$ If $V_{EVSE \ min} - (R1+R2) \times I_{EVSEmax} \geq 0 \text{ V}$ 2) Send $V_{EV \ target} = \min(P_{EVSE \ max} / I_{EVSE \ max}; V_{EVSE \ max})$ $I_{EV \ target} = I_{EVSE \ max}$ 3) Wait for T_{wait} (see definition below) in order to reach steady state operation before measuring. $T_{wait} = 2 \text{ s} + 1.1 \times I_{EVSE \ max} / 20 \text{ A/s}$ 4) Connect test resistors according to the respective configuration. 5) Wait until EV Supply equipment has turned off CP oscillator. 6) Disconnect test resistors. 7) Change CP state to state A, wait for 1 min (to allow the station to perform a self test) and change CP state to state B. 8) Set $V1 = V_{EVSE \ min} - (R1+R2) \times I_{EVSEmax}$ If $V_{EVSE \ min} - (R1+R2) \times I_{EVSEmax} < 0 \text{ V}$ then set $V1 = 0 \text{ V}$ 9) Send $V_{EV \ target} = \min(P_{EVSE \ max} / I_{EVSE \ max}; V_{EVSE \ max})$ $I_{EV \ target} = I_{EVSE \ max}$ 10) Wait for T_{wait} (see definition below) in order to reach steady state operation before measuring. $T_{wait} = 2 \text{ s} + 1.1 \times I_{EVSE \ max} / 20 \text{ A/s}$
Expected results
<p>The charging sequence shall be successfully done until $t = t9$ according to Fig. 21, that is energy transfer in steady state.</p>

NOTE — It may be noted that the above sequence shall be followed by both the charging guns. There shall be a time difference of “t” s between SECC1 and SECC2 as specified by OEMs.

A-9.3.16 Short-Circuit between CP and PE

The compliance test is shown in [Table 42](#).

Table 42 Compliance test for Short-Circuit between CP and PE

(Clause [A-9.3.16](#))

Matching to requirement (chapter)	Table 2 (state d.c.-E)
Short description	
Check if d.c. electric vehicle supply equipment will perform an emergency shutdown in case of: Short circuit between CP and PE	
Pre-conditions	
<p>The d.c. electric vehicle supply equipment has successfully transmitted its following properties to the EV-simulator:</p> <p>$V_{EVSE\ min}$, $V_{EVSE\ max}$, $I_{EVSE\ min}$, $I_{EVSE\ max}$, $P_{EVSE\ max}$</p> <p>The charging sequence shall be successfully done until $t = t_9$ according to Fig. 21, including the message “PowerDeliveryReq” (according to IS/ISO 15118), with the following values used during pre-charging:</p> <p>$V_1 = V_{EVSE\ min} - (R_1 + R_2) \times I_{EVSE\ min}$ if $V_{EVSE\ min} \geq (R_1 + R_2) \times I_{EVSE\ min}$</p> <p>and:</p> <p>$V_1 = 0\ V$ if $V_{EVSE\ min} < (R_1 + R_2) \times I_{EVSE\ min}$</p> <p>and the parameters “EVTargetVoltage” in message “PreChargeReq” (according to IS/ISO 15118):</p> <p>EV target voltage = $V_{EV\ target} = V_{EVSE\ min}$</p>	
Test setup	
Standard test setup, additionally relay to short circuit CP and PE	
	
<p>FIG. 37 EXAMPLE OF BLOCK DIAGRAM OF BI-DIRECTIONAL POWER FLOW SYSTEM</p>	
Action(s)	
<p>The EV-simulator shall issue current requests and, if applicable voltage requests.</p> <p>The message “CurrentDemandReq” according to IS/ISO 15118 shall contain the following parameters:</p> <p>EV target current = $I_{EV\ target}$</p> <p>EV target voltage = $V_{EV\ target}$</p> <p>Definition of intended test point (OP5):</p> <p>$I_{EVSE\ intended} = I_{EVSE\ max}$</p> <p>$V_{EVSE\ intended} = V_{EVSE\ min}$</p>	

Table 42 (Concluded)

<p>1) Set:</p> $V1 = V_{EVSE\ min} - (R1+R2) \times I_{EVSE\ max}$ <p>If $V_{EVSE\ min} - (R1+R2) \times I_{EVSE\ max} \geq 0\ V$</p> <p>2) Send:</p> $I_{EV\ target} = I_{EVSE\ max}$ $V_{EV\ target} = \min (P_{EVSE\ max}/I_{EVSE\ max}; V_{EVSE\ max})$ <p>3) Wait for T_{wait} (<i>see</i> definition below) in order to reach steady state operation before measuring</p> $T_{wait} = 2\ s + 1.1 \times I_{EVSE\ max} / 20\ A/s$ <p>4) Close relay between CP and PE</p>
Expected results
After 1 s the output current of the d.c. electric vehicle Supply equipment ($I_{Electric\ VehicleSE\ Output}$) shall be $< 5\ A$

A-9.3.17 Short-Circuit and Overcurrent Protection during Charging

The compliance test is shown in [Table 43](#).

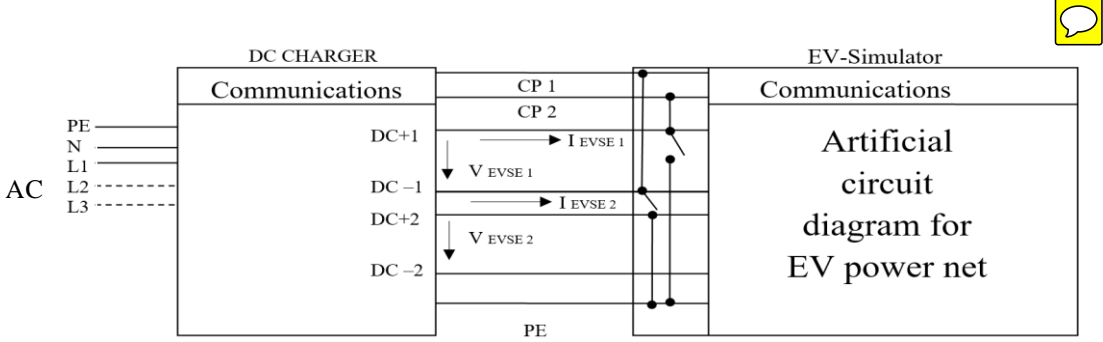
Table 43 Compliance test for Short-Circuit and Overcurrent Protection

(Clause [A-9.3.17](#))

Matching to requirement (chapter)	13.101 Short-circuit protection of the d.c. connection A-6.6  current protection of the d.c. connection
Short description	
Reaction on over-current condition caused by external or internal faults	
Pre-conditions	
<p>The electric vehicle Supply equipment has successfully transmitted its following properties to the EV-simulator:</p> <p>$V_{EVSE\ min}$, $V_{EVSE\ max}$, $I_{EVSE\ min}$, $I_{EVSE\ max}$, $P_{EVSE\ max}$</p> <p>The charging sequence shall be successfully done until $t=t9$ according to Fig. 21, including the message “PowerDeliveryReq” (according to IS/ISO 15118), with the following values used during pre-charging:</p> <p>$V1 = V_{EVSE\ min} - (R1 + R2) \times I_{EVSE\ min}$ if $V_{EVSE\ min} \geq (R1 + R2) \times I_{EVSE\ min}$</p> <p>and</p> <p>$V1 = 0\ V$ if $V_{EVSE\ min} < (R1 + R2) \times I_{EVSE\ min}$</p> <p>and the parameters “EVTargetVoltage” in message “PreChargeReq” (according to IS/ISO 15118)</p> <p>$EVTargetVoltage = V_{EV\ target} = V_{EVSE\ min}$</p>	

Table 43 (Continued)

Test setup													
<p>The following figure shows a test setup with additional means to create over-current conditions (fault insertion).</p>													
<p>FIG. 38 EV CHARGING AND DISCHARGING MODES </p>													
<p>The test device shall be configurable with following characteristics:</p> <table border="1" style="width: 100%; border-collapse: collapse;"> <thead> <tr> <th></th> <th>Resistance R_{test}</th> <th>Inductance L_{test}</th> </tr> </thead> <tbody> <tr> <td>Configuration 1</td> <td>$10\text{ m}\Omega \pm 15\text{ percent}$</td> <td>$2\text{ }\mu\text{H} \leq L_{test} \leq 5\text{ }\mu\text{H}$</td> </tr> <tr> <td>Configuration 2</td> <td>$100\text{ m}\Omega \pm 10\text{ percent}$</td> <td>$2\text{ }\mu\text{H} \leq L_{test} \leq 5\text{ }\mu\text{H}$</td> </tr> <tr> <td>Configuration 3</td> <td>$250\text{ m}\Omega \pm 10\text{ percent}$</td> <td>$2\text{ }\mu\text{H} \leq L_{test} \leq 5\text{ }\mu\text{H}$</td> </tr> </tbody> </table> <p>R_{test} is the resistance of the short-circuit loop of the test device. It shall be measured between the d.c. + and d.c. - contact of the test device inlet at a frequency of $f_{meas} = 1\text{ kHz}$ (EV-simulator disconnected).</p> <p>L_{test} is the inductance of the short-circuit loop of the test device. It shall be measured between the d.c.+ and d.c. - contact of the test device inlet at a frequency of $f_{meas} = 1\text{ kHz}$ (EV-simulator disconnected).</p> <p>The bandwidth of the current and voltage measurement shall be at least 500 kHz.</p> <p>Contact bouncing of the switching device M shall be avoided by selecting an appropriate switching device.</p>			Resistance R_{test}	Inductance L_{test}	Configuration 1	$10\text{ m}\Omega \pm 15\text{ percent}$	$2\text{ }\mu\text{H} \leq L_{test} \leq 5\text{ }\mu\text{H}$	Configuration 2	$100\text{ m}\Omega \pm 10\text{ percent}$	$2\text{ }\mu\text{H} \leq L_{test} \leq 5\text{ }\mu\text{H}$	Configuration 3	$250\text{ m}\Omega \pm 10\text{ percent}$	$2\text{ }\mu\text{H} \leq L_{test} \leq 5\text{ }\mu\text{H}$
	Resistance R_{test}	Inductance L_{test}											
Configuration 1	$10\text{ m}\Omega \pm 15\text{ percent}$	$2\text{ }\mu\text{H} \leq L_{test} \leq 5\text{ }\mu\text{H}$											
Configuration 2	$100\text{ m}\Omega \pm 10\text{ percent}$	$2\text{ }\mu\text{H} \leq L_{test} \leq 5\text{ }\mu\text{H}$											
Configuration 3	$250\text{ m}\Omega \pm 10\text{ percent}$	$2\text{ }\mu\text{H} \leq L_{test} \leq 5\text{ }\mu\text{H}$											
Action(s)													
<p>This test case shall be executed in single steps as indicated below:</p> <p>In each test step, the EV-simulator shall issue current/voltage requests (that is, “CurrentDemandReq” in case of PLC communication according to IS/SO 15118) with the parameter as given in the list below:</p> <p>EV target current = $I_{EV\ target}$</p> <p>EV target voltage = $V_{EV\ target}$</p> <p>Main actions to be performed for all test points:</p> <p>For each test point TP conduct three single tests using the settings 1, 2 and 3 of the test device as specified in the test setup.</p> <p>Set V1 to the values as defined below.</p> <p>For each test point TP request $I_{EV\ target}$ and $V_{EV\ target}$ with the values as defined below.</p> <p>Wait until steady state operation is reached</p> <p>Close switch M.</p> <p>Measure and log EV supply equipment output current $I_{EVSE\ Output}$ and output voltage $V_{EVSE\ Output}$ from the point in time when switch M is closed until the point in time when the d.c. EV supply equipment has shut down.</p>													

Table 43 (Concluded)

<p>Open switch M</p> <p>Calculations:</p> <p>Determine</p> $\sum_n i_n^2 \Delta t_{sample}$ <p>from the point in time when switch M is closed until the point in time when the d.c. electric vehicle supply equipment has shut down.</p> <p>Target values requested to set test points:</p> <p>Step 1:</p> $I_{EV \text{ target}} = I_{EVSE \text{ max}}$ $V_{EV \text{ target}} = P_{EVSE \text{ max}} / I_{EVSE \text{ max}}$ <p>Step 2:</p> $I_{EV \text{ target}} = P_{EVSE \text{ max}} / V_{EVSE \text{ max}}$ $V_{EV \text{ target}} = V_{EVSE \text{ max}}$ <p>Configuration of the test bench for all steps:</p> $V1 = V_{EV \text{ target}} - (R1 + R2) \times I_{EV \text{ target}}$ <p>with $V1 \geq 0 \text{ V}$</p>
<p>Expected results</p>
<p>Short-circuit peak current $\leq 10 \text{ kA}$.</p> $\sum_n i_n^2 \Delta t_{sample} \leq 1\ 000\ 000 \text{ A}^2\text{s}$ <p>d.c. output current drops below 5 A within 1.03 s after closing of switch M.</p>

A-9.3.18 Test of Measured Voltage Values during Welding Detection

The compliance test is shown in [Table 44](#).

Table 44 Compliance Test for Measured Voltage Values During Welding Detection

(Clause [A-9.3.18](#))

Matching to requirement (chapter)	Table 17 Sequence description for normal shutdown (t106-- > t107) A-6.5 Measuring current and voltage
Short description	
Check if the voltage values measured by the d.c. electric vehicle supply equipment and transferred via digital communication are correct.	
Pre-conditions	
<p>The d.c. electric vehicle supply equipment has successfully transmitted its following properties to the EV-simulator:</p> <p>$V_{EVSE\ min}$, $V_{EVSE\ max}$, $I_{EVSE\ min}$, $I_{EVSE\ max}$, $P_{EVSE\ max}$</p> <p>The charging sequence shall be successfully done until $t = t105$ according to Fig. 22, including the message “PowerDeliveryReq” (according to IS/ISO 15118), with the following values used during pre-charging and current demand:</p> <p>$V1 = V_{EVSE\ min} - (R1 + R2) \times I_{EVSE\ min}$ if $V_{EVSE\ min} \geq (R1 + R2) \times I_{EVSE\ min}$</p> <p>and:</p> <p>$V1 = 0\ V$ if $V_{EVSE\ min} < (R1 + R2) \times I_{EVSE\ min}$</p> <p>and the parameters “EVTARGETVOLTAGE” in message “PreChargeReq” and “CurrentDemandReq” (according to IS/ISO 15118):</p> <p>EV target voltage = $V_{EV\ target} = V_{EVSE\ min}$</p>	
Test setup	
Standard test setup	
Action(s)	
<p>1) a. set:</p> <p style="padding-left: 40px;">$V1 = V_{EVSE\ min}$</p> <p>b. send:</p> <p style="padding-left: 40px;">WeldingDetectionReq (according to IS/ISO 15118)</p> <p>c. receive WeldingDetectionRes</p> <p>d. compare received value “EVSEPresentVoltage” with V1</p> <p>2) a. set:</p> <p style="padding-left: 40px;">$V1 = V_{EVSE\ max} - (V_{EVSE\ max} - V_{EVSE\ min})/2$</p> <p>b. send:</p> <p style="padding-left: 40px;">WeldingDetectionReq (according to IS/ISO 15118)</p> <p>c. receive WeldingDetectionRes</p>	

<p>d. compare received value “EVSEPresentVoltage” with V1</p> <p>3) a. set:</p> $V1 = V_{EVSE\ max}$ <p>b. send:</p> <p>WeldingDetectionReq (according to IS/ISO 15118)</p> <p>c. receive WeldingDetectionRes</p> <p>d. compare received value “EVSEPresentVoltage” with V1</p>
Expected results
<p>All received values for “EVSEPresentVoltage” > 0;</p> <p>$IV1 - EVSEPresentVoltageI \leq 10\ V$</p>

NOTE — It may be noted that the above sequence shall be followed by both the charging guns. There shall be a time difference of “t” s between SECC1 and SECC2 as specified by OEMs.

A-9.3.19 User Initiated Shutdown

The compliance test is shown in [Table 45](#).

Table 45 Compliance test for User Initiated Shutdown

(Clause [A-9.3.19](#))

Matching to requirement (chapter)	6.3.1.110 User initiated shutdown
Short description	
Check if d.c. EV supply equipment performs an user initiated shut down.	
Pre-conditions	
<p>The EV supply equipment has successfully transmitted its following properties to the EV-simulator:</p> $V_{EVSE\ min}, V_{EVSE\ max}, I_{EVSE\ min}, I_{EVSE\ max}, P_{EVSE\ max}$ <p>The charging sequence shall be successfully done until $t = t9$ according to Fig. 21, including the message “PowerDeliveryReq” (according to IS/ISO 15118), with the following values used during pre-charging:</p> $V1 = V_{EVSE\ min} - (R1 + R2) \times I_{EVSE\ min} \quad \text{if} \quad V_{EVSE\ min} \geq (R1 + R2) \times I_{EVSE\ min}$ <p>and:</p> $V1 = 0\ V \quad \text{if} \quad V_{EVSE\ min} < (R1 + R2) \times I_{EVSE\ min}$ <p>and the parameters “EVTargetVoltage” in message “PreChargeReq” (according to IS/ISO 15118):</p> $EV\ target\ voltage = V_{EV\ target} = V_{EVSE\ min}$	
Test setup	
Standard test setup	
Action(s)	
<p>The EV-simulator shall issue current requests and, if applicable voltage requests.</p> <p>The message “CurrentDemandReq” according to IS/ISO 15118 shall contain the following parameters:</p> $EV\ target\ current = I_{EV\ target}$ $EV\ target\ voltage = V_{EV\ target}$	

<p>Definition of intended test point (OP5):</p> $I_{EVSE\ intended} = I_{EVSE\ max}$ $V_{EVSE\ intended} = V_{EVSE\ min}$ <p>1) Set:</p> $V1 = V_{EVSE\ min} - (R1+R2) \times I_{EVSE\ max}$ <p>If $V_{EVSE\ min} - (R1+R2) \times I_{EVSE\ max} \geq 0\ V$</p> <p>2) Send:</p> $I_{EV\ target} = I_{EVSE\ max}$ $V_{EV\ target} = \min (P_{EVSE\ max}/I_{EVSE\ max}; V_{EVSE\ max})$ <p>3) Wait for T_{wait} (<i>see</i> definition below) in order to reach steady state operation before measuring</p> $T_{wait} = 2\ s + 1.1 \times I_{EVSE\ max} / 20\ A/s$ <p>4) Activate the customer means to shut down the charging process.</p>
<p>Expected results</p> <p>Electric vehicle supply equipment sends a “CurrentDemandRes” containing the parameter “EVSEStatusCode = EVSE_Shutdown”</p>

NOTE — It may be noted that the above sequence shall be followed by both the charging guns. There shall be a time difference of “t” s between SECC1 and SECC2 as specified by OEMs.

A-9.3.20 Short Circuit Test before Charging

The compliance test is shown in [Table 46](#).

Table 46 Compliance Test for Short Circuit Test before Charging

(Clause [A-9.3.20](#))

Matching Requirement (Chapter)	6.3.1.109 Short circuit check before charging
Short description	
Reaction on short circuit between d.c. +/d.c. - before charging.	
Pre-conditions	
The electric vehicle supply equipment has successfully transmitted its following properties to the Electric Vehicle-simulator: $V_{EVSE\ min}, V_{EVSE\ max}, I_{EVSE\ min}, I_{EVSE\ max}, P_{EVSE\ max}$	
The charging sequence shall be successfully done until $t = t4$ according to Fig. 21 .	
Test setup	
Standard test setup with additional contactor to short circuit d.c. +/d.c. -	
Action(s)	
1) Close the contactor between d.c.+ and d.c.-	
2) The EV-simulator shall perform the cable check sequence (that is send “CableCheckReq” according to IS/ISO 15118).	
Expected results	
The electric vehicle supply equipment shall turn off the CP oscillator.	

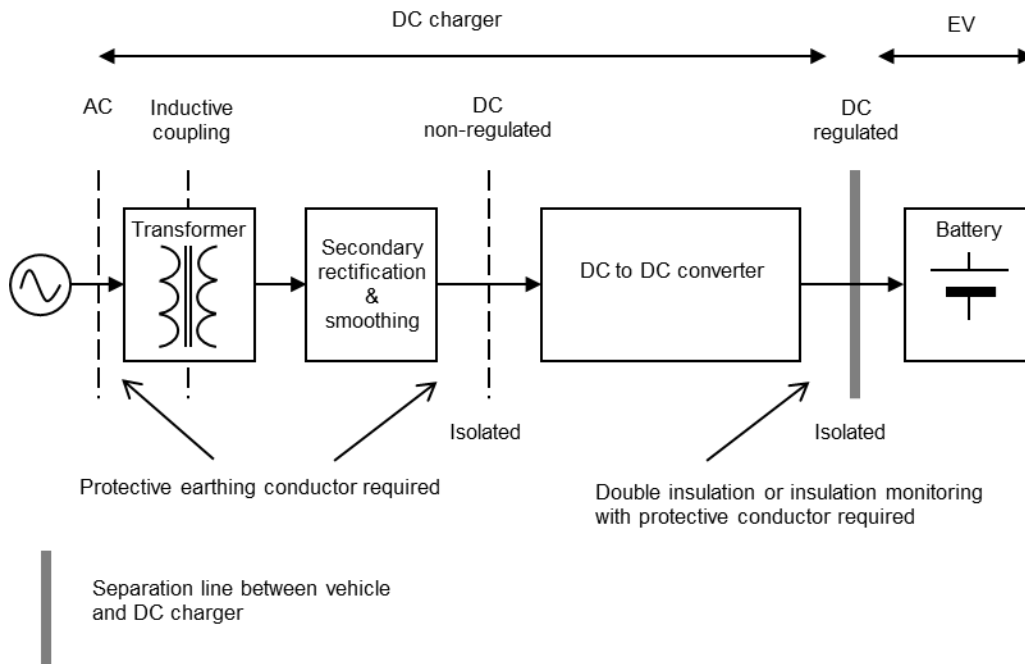

FIG. 41 EXAMPLE OF SIMPLIFIED ISOLATED SYSTEM

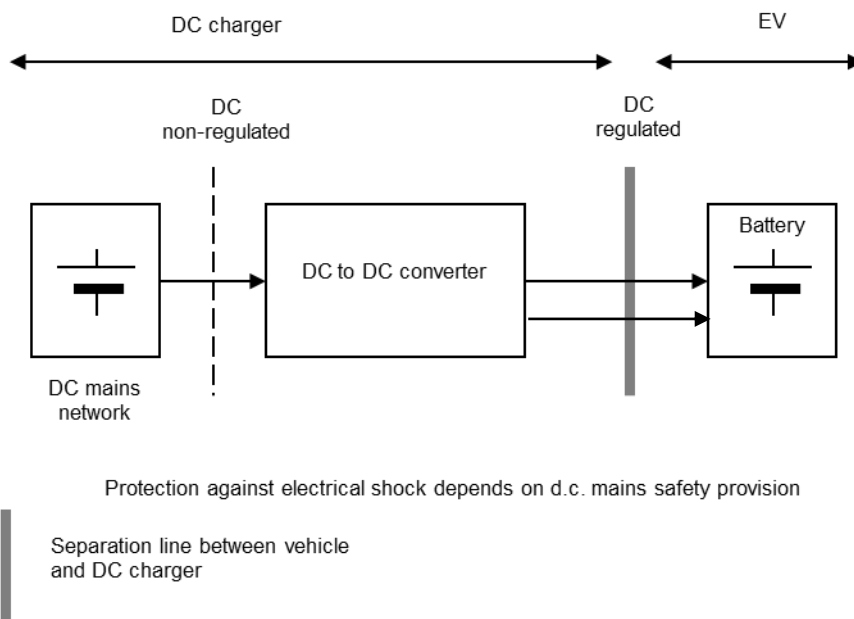
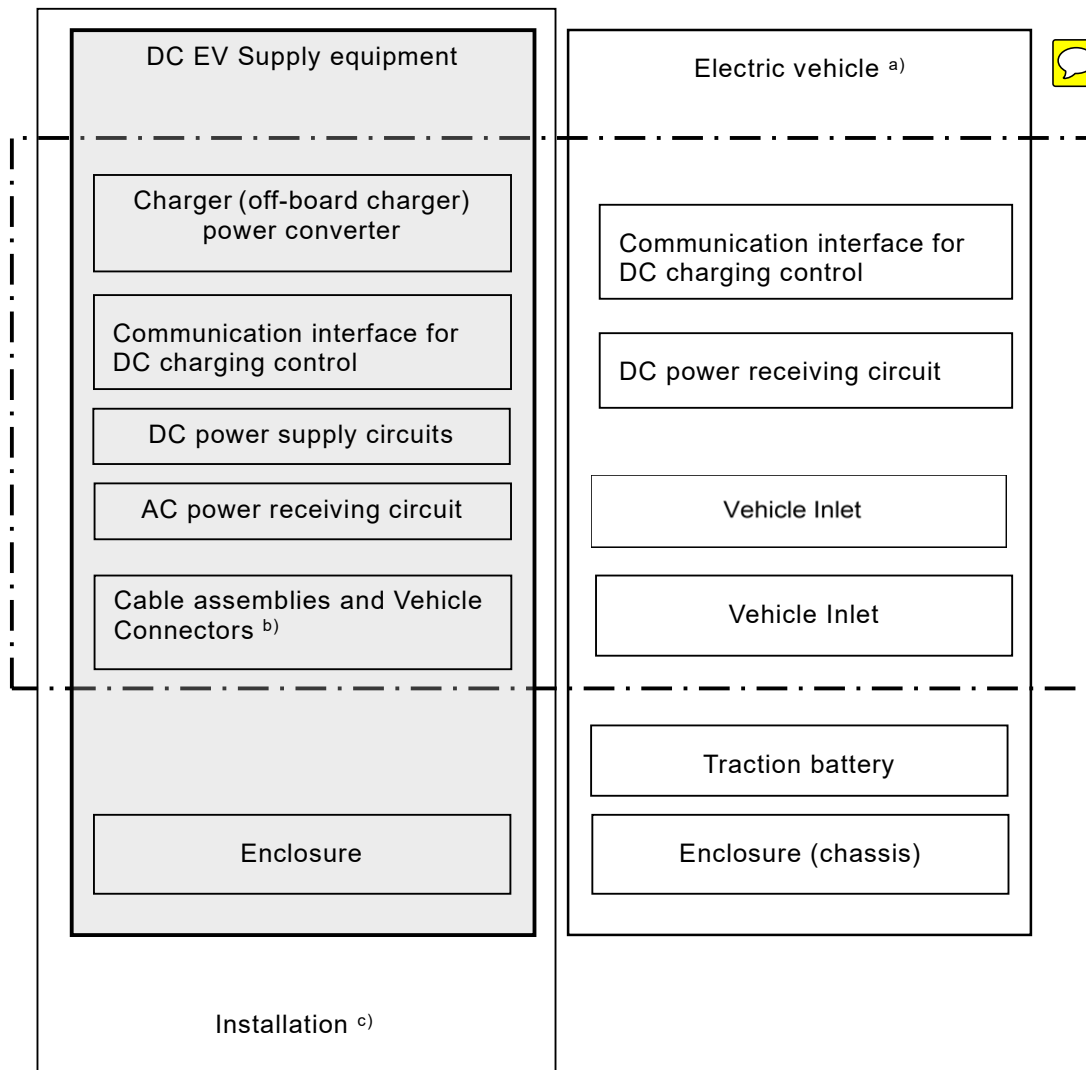

FIG. 42 EXAMPLE OF d.c. SUPPLY NETWORK SYSTEM



Key

- Scope of IS 17017(Part XX)
- d.c. electric vehicle charging system (see [Annex A](#) and [Annex B](#))

- a) Including information on element of electric vehicle for conductive connection;
- b) Detailed requirements for d.c. vehicle couplers are defined in IS 17017 (Part 2/Sec 3). Requirements for cable assemblies are specified in IS 17017 (Part 2/Sec 1); and
- c) Installation (see IEC 60364-7-722) is also applicable for connecting points (standard socket-outlets) intended to supply plug and cable d.c. electric vehicle supply equipment.

FIG. 43 TYPICAL CONFIGURATION OF d.c. CHARGING SYSTEM

ANNEX C

(Clause [101.3](#))**MULTIOUTLET (a.c./d.c. ISOLATED) d.c. EV SUPPLY EQUIPMENT****C-1 GENERAL**

This annex provides specific requirements for d.c. charging by using a multi-outlet d.c. EV supply equipment. Multi-outlet d.c. electric vehicle supply equipments are d.c. electric vehicle supply equipment with two or more d.c. connecting points. As a part of the d.c. electric vehicle supply equipment, all general requirements for d.c. electric vehicle supply equipments also apply to the multi-outlet d.c. electric vehicle supply equipment unless otherwise specified in this annex.

C-2 CONSTRUCTIONAL REQUIREMENTS**C-2.1 Constructional Requirements of d.c. output System**

The d.c. output system shall be equipped with a vehicle connector according to IS 17017 (Part 2/Sec 3) and a non-detachable charging cable.

A storage means according to **11**  all be provided for all vehicle connectors when not in use. The maximum cable length shall be in accordance with national codes. Clearance and creepage distance of contactors in open state shall be at least basic insulation.

The d.c. output system shall also be equipped with a mechanical disconnection device such as relay/contactor for each charging gun. The device shall be installed in each of the positive and negative power line of the d.c. output circuit of the supply equipment, and be capable of disconnecting the power line of the d.c. electric vehicle supply equipment from the electric vehicle when the system is operating under the maximum rated charging

current in simultaneous operation.

C-2.1.1 Constructional Requirements of d.c. Output System According to Annex A

The d.c. Output system shall be equipped with a vehicle connector according to IS 17017 (Part 2/Sec 3), configuration FF. To ensure proper functionality, the d.c. output system shall be equipped with the necessary hardware for communication and power transmission (for example, PWM oscillator, PLC chip, contactors), according to Annex A, Fig. 29 and Fig. A-1 of IS 17017 (Part 1) : 2018.

C-3 d.c. OUTPUT SYSTEM PERFORMANCE**C-3.1 General Performance Requirements**

The output systems shall be System C. The d.c. output performance shall comply with the mentioned requirements. If two or more outputs can be used simultaneously, mutual interference shall not occur. It shall be ensured that all the sequences followed by both the charging guns shall be at a time difference of “t” s between SECC1 and SECC2 as specified by OEMs.

C-3.2 Performance of Multi-Outlet d.c. EV Supply Equipments providing Simultaneous Operation

If the sum of the rated powers of each output circuit exceeds the power rating of the multi-outlet d.c. EV Supply equipment, the manufacturer has to specify the possibilities of power distribution in the user’s manual (for example, priority charging or evenly distributed power on each output circuit).

C-3.3 Architecture

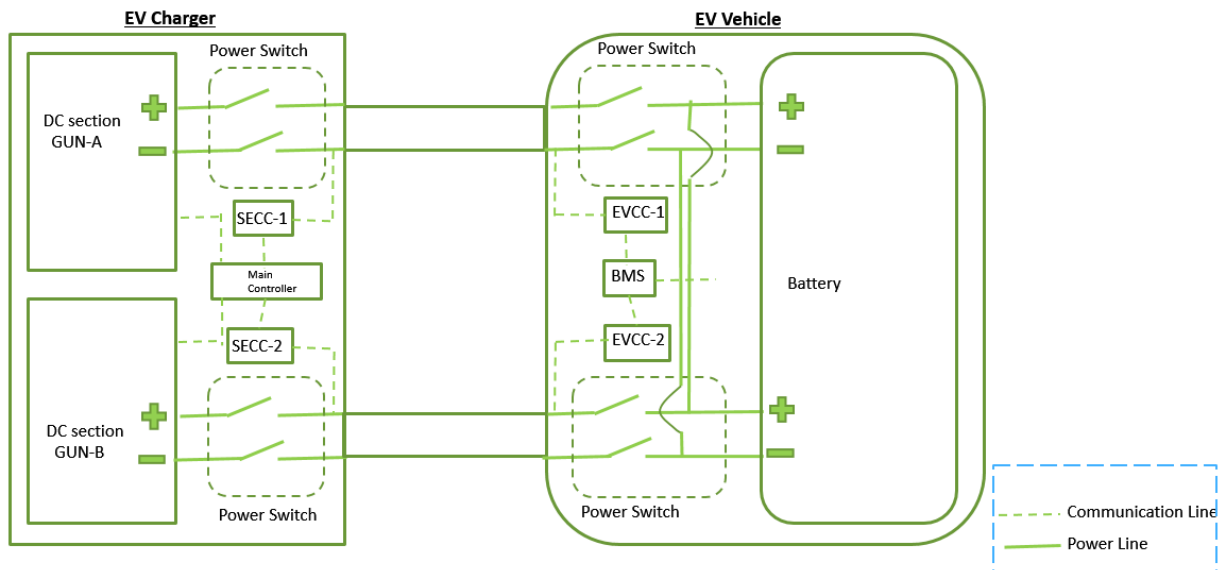

FIG. 44 DUAL-SOCKET ARCHITECTURE

C-3.4 Charging Phase

Main phases of charging process (normal start up, charging and normal shutdown) includes the following:

- a) Disconnection phase;
- b) Initialization;
- c) Insulation check;
- d) Pre-charge;
- e) Energy transfer (with normal shutdown at the end of charging);
- f) Session stop (normal shutdown and emergency shutdown);
- g) Welded check (optional) and unlocking; and
- h) Disconnection

C-3.4.1 Connection Phase

At the time of connection of charging gun(s) to the electric vehicle, the operator shall select either of

the settings for charging, specified as under:

- a) Setting 1: Charging with 1 gun – For single socket vehicle; and
- b) Setting 2: Charging with 2 guns – For dual socket vehicle.

NOTE — It shall be ensured that when the Dual guns are used for charging two vehicles separately, the communication and the power transfer shall be as per IS 17017-23 and IS 17017-24 only.

C-3.4.2 Initialization Phase

In case of selection of charging with two guns (for dual socket vehicle charging), both the charging guns shall be plugged in. The d.c. electric vehicle supply equipment shall start initialization on first charging gun (Gun A). After command completion of initialization of charging Gun A and time elapse of “t” s, initialization on other charging gun (Gun B) shall start. The default value of “t” shall be set in d.c. electric vehicle supply equipment based on actual integration with vehicle.

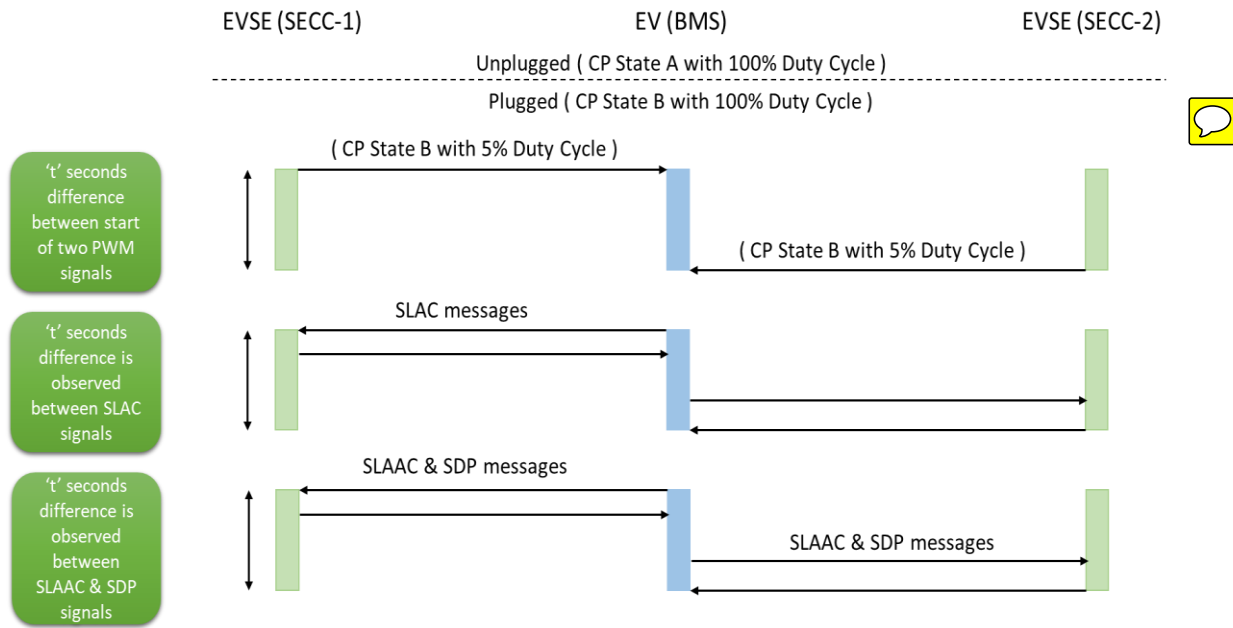

FIG. 45 CHARGING PHASES FOR DUAL GUN CHARGING

C-3.4.3 Insulation check

On charging with two guns (for dual socket vehicle charging), both the EVCC shall send CableCheckReq and SECC shall respond through CableCheckResp. The vehicle shall have an insulation monitoring device (IMD) for verifying the adequacy of insulation check level and measurement shall be responded to EVCC (through Cable Check Res).

After command completion of insulation check of charging Gun A and time elapse of “t” s, insulation check on other charging gun (Gun B) shall start. The default value of “t” shall be set in d.c. electric vehicle supply equipment based on actual integration with vehicle.

C-3.4.4 Pre-charge

The pre-charge phase initiates with sending of pre-charge request by electric vehicle which contains information on requested d.c. current and d.c. voltage.

The d.c. electric vehicle supply equipment shall adapt the d.c. output voltage to requested value and shall limit the output current to a maximum value of 2 A.

C-3.4.5 Energy Transfer (with Normal Shutdown at the End of Charging)

Based on the requested values by EV, d.c. electric vehicle supply equipment adapts and reports the

current and voltage limit level, real time output current and voltage, and the status to EV through Current Demand Res.

C-3.4.6 Session Stop (Normal Shutdown and Emergency Shutdown)

In case of fault occurrence or charging completion, EV stops the charging process. Accordingly, charger shall respond to stop the charging through operation of disconnection device (at current less than 1 A).

C-3.4.7 Welded check and Unlocking

After timeout or receipt of PowerDeliverRes message, EV shall change CP state to B. EV may optionally perform its welded contactor check by sending Welding Detection Req/Welding Detection Res while the sequence finished is “false”. After implementation of welding detection, EV status shall be “not ready” and its disconnection device shall be open. EV shall unlock the connector after d.c. output has dropped below 60 V.

C-3.4.8 Disconnection

In case of an alarming signal, if charging by any charging gun is terminated by EV, charging shall also terminate on the other charging gun.

C-3.5 Communication Protocol between EVSE and CMS

The communication protocol between d.c. electric vehicle supply equipment and central management system (CMS) shall be as per Fig. 46.

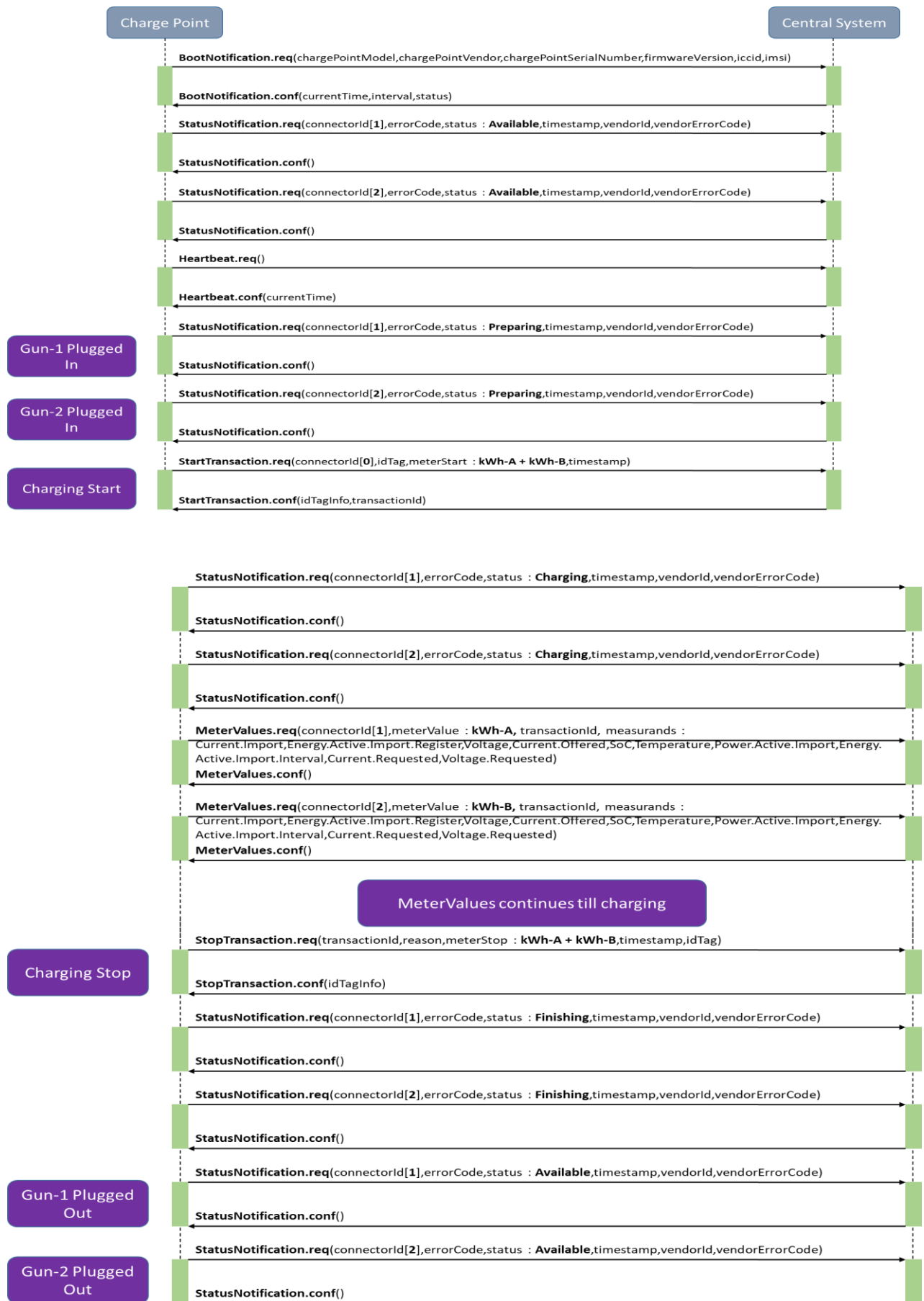

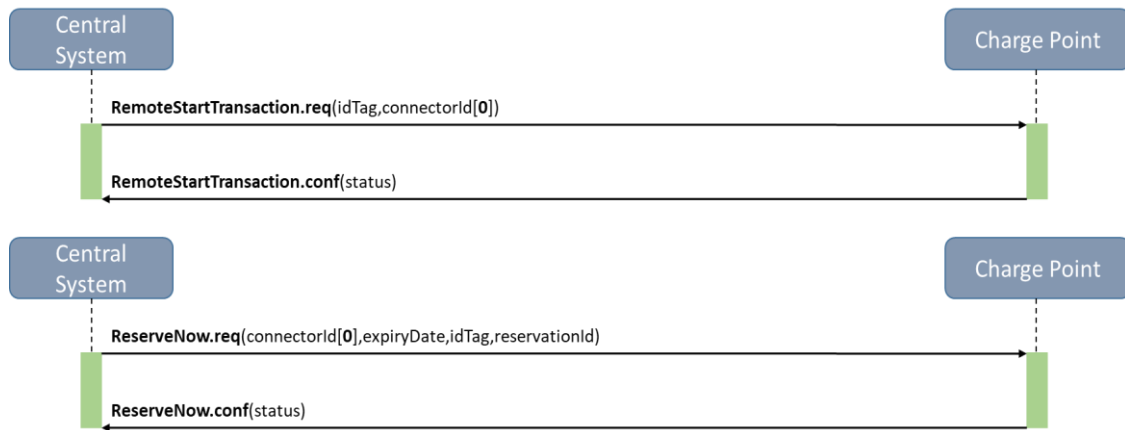

FIG. 46 COMMUNICATION PROTOCOL BETWEEN EVSE AND CMS

C-4 SAFETY REQUIREMENTS

C-4.1 General Safety Requirements

The protective conductor in each charging cable of the multi-outlet d.c. electric vehicle supply equipment shall be connected to a common protective earthing conductor.

All output circuits shall be individually equipped with a means of insulation monitoring or d.c. leakage current monitoring, between d.c. power conductor and enclosure of d.c. EV supply equipment, as specified in [Annex A](#). Y capacitance at the output terminal of each output circuit shall comply with the requirement in [8.105.1](#).

The reaction time of an IMD shall not be influenced during simultaneous operation with an earth leakage current measuring device or other insulation monitoring device.

Circuit components including devices used for isolation shall be rated for the maximum voltage including all specified tolerances of the power output circuits taking into account both normal and single insulation fault.

C-4.2 Short-Circuit Protection

Each connecting point of a multi-outlet d.c. EV charging shall have individual short-circuit protection means. Such means shall comply with the requirement of respective output system given in [13.101](#).

C-4.3 Overload Protection

Each connecting point of a multi-outlet d.c. electric vehicle supply equipment shall individually provide overload protection according to [13.2](#).

C-4.4 Access to Energized Part through Unmated Vehicle Connector during Charge

During charge, conductor connected to the accessible unmated vehicle connector shall be isolated by basic or reinforced insulation from the energized d.c. output.

If isolation is achieved by basic insulation, the energy or voltage between a contact of unmated vehicle connector and earth shall be less than or equal to 0.5 mJ or 28 V d.c. continuously in normal operation and after 1 s under a first fault.

Requirement for the insulation barrier specified in [8.105.3](#) shall be applied to each d.c. output circuit.

C-4.5 Additional Safety Requirements for Multi-Outlet d.c. EV Supply Equipments Providing Simultaneous Operation

If the output systems are equipped with switch components, such as contactors, measures shall be taken to prevent unintended electrical connection of vehicles caused by the failure of switch component. The protection can be achieved by one or combination of the following measures:

- Allocation of diode interlock of to each output circuit. The diode shall be installed between switch component and output terminal of each outlet;
- Allocation of fuse to the circuit equipped with switch component; and
- Electrical or mechanical contactors for preventing simultaneous closure.

If a fault is detected in one output circuit, the multi-outlet d.c. EV supply equipment shall terminate the supply of charging current in all output circuits.

C-4.6 Diagnostic Check of Mechanical Disconnection Device in d.c. Output System

The multi-outlet d.c. electric vehicle supply equipment shall perform the diagnostic check of the mechanical disconnection device installed in the d.c. output system to prevent unexpected power flow from a vehicle to the d.c. electric vehicle supply equipment, or between the two or more vehicles simultaneously connected to the d.c. electric vehicle supply equipment in case the mechanical disconnection device is welded (ON stuck), and to prevent hazardous voltage at the unmated vehicle connector.

As the minimum requirement, the diagnostic shall check the welding (ON stuck) of the mechanical disconnection device. Diagnostic checks of other failures such as OFF stuck and erratic actuation are

not mandatory but still recommended.

If the diagnostic check is performed before the start of charging and the ON stuck failure is detected, the charging process shall be terminated and the system shall transfer to shutdown sequence.

If the diagnostic check is performed after the completion of a single charging event and the ON stuck failure is detected, the d.c. electric vehicle supply equipment shall prohibit further charging events until the mechanical disconnection device is properly replaced or repaired.

C-4.7 Safety Requirements for Multi-Outlet d.c. Electric Vehicle Supply Equipments with shared d.c.

Under consideration.

ANNEX D

(Clauses 6.3.1.104 and 7.1)

COMMUNICATION AND CHARGING PROCESS BETWEEN d.c. ELECTRIC VEHICLE SUPPLY EQUIPMENT AND ELECTRIC VEHICLE

D-1 DIGITAL COMMUNICATION BETWEEN THE EV SUPPLY EQUIPMENT AND THE ELECTRIC VEHICLE**D-1.1 General**

This annex provides the general information on the communication and charging process between d.c. electric vehicle supply equipment and electric vehicle.

The requirements of digital communication of charging control between d.c. electric vehicle supply equipment and electric vehicle are defined in IS 17017 (Part 24).

Electric vehicles are equipped with propulsion batteries with different technologies and voltage. Accordingly, the charging process is managed by the vehicle in order to ensure the charging of different types of on-board energy storage systems.

Electric vehicles are equipped with VCCF for charging process management. The d.c. electric vehicle supply equipments have a means allowing the vehicles to control the charging parameters of d.c. electric vehicle supply equipment.

It shall be ensured that all the sequences followed by both the charging guns shall be at a time difference of “t” s between SECC1 and SECC2 as specified by OEMs.

D-1.2 System Configuration

The communication between the d.c. electric vehicle supply equipment and the vehicle can be established via basic communication and high-level communications.

Key steps in the charging control process, such as start of charging and normal/emergency shutdown, is managed through the basic communication with signal exchange via the control pilot lines in d.c. electric vehicle charging system.

In addition to the basic communication, the d.c. electric vehicle supply equipment is equipped with digital communication means in order to exchange the control parameters for d.c. charging between the d.c. electric vehicle supply equipment and the vehicle through the high-level communication. The following digital communication means are used by the systems defined in [Annex A](#):

- a) Power line communication (PLC) over control pilot circuit.

D-1.3 Charging Control Process and State**D-1.3.1 General**

Charging control process of d.c. electric vehicle supply equipments consists of the following three stages:

- a) process before the start of charging (initialization): Initialization includes pre-charge if required. Pre-charge is the final stage of initialization;
- b) process during charging (energy transfer); and
- c) process of shutdown (shutdown).

The d.c. electric vehicle supply equipment and the vehicle synchronize control process with each other. The following signals and information are used for the synchronization:

- a) signals through the pilot wire circuit;
- b) parameters through the digital communication circuit; and
- c) measurement values such as voltage and current level of the d.c. charging circuit through the digital communication circuit.

The d.c. electric vehicle supply equipment and the vehicle preserve specified time constraints and control timings for ensuring smooth charging control and operation.

Charging sequence diagrams are system specific and described in [Annex A](#). Digital communication parameters, formats, and other communication requirements are specified in IS 17017 (Part 24).

D-1.3.2 Description of the Process before the Start of Charging (Initialization)

In this process, the vehicle and the d.c. electric vehicle supply equipment exchange their operational limitations and relevant parameters for charging control. Messages, such as the voltage limit, maximum charging current, etc. are also transferred to each other. Circuit voltage is measured for checking whether the batteries and the d.c. electric vehicle supply equipment are connected before the start of charging and whether the batteries and the d.c. electric vehicle supply equipment are disconnected after the end of charging. The d.c. electric vehicle supply equipment is not to proceed with the next stage of charging process unless it verifies the compatibility with the vehicle. After compatibility check, the d.c. electric vehicle supply

equipment conducts the insulation check between the d.c. power lines and the enclosures, including vehicle chassis. The vehicle connector is latched before the insulation check.

D-1.3.3 *Description of the Process During Charging (Energy Transfer)*

In this process, the vehicle continues to send a setting value of charging current or voltage to the d.c. electric vehicle supply equipment throughout charging process. Either of the following two algorithms is taken:

a) CCC

- 1) The vehicle battery can be charged using CCC with the vehicle as master and the d.c. electric vehicle supply equipment as slave;
- 2) The d.c. electric vehicle supply equipment receives the charging current value the vehicle requested (command value), throughout the charging control process;
- 3) The d.c. electric vehicle supply equipment sets the command value as control target, and regulate the d.c. charging current;
- 4) The command value from the vehicle is notified to the d.c. electric vehicle supply equipment at regular intervals according to the system requirements; and
- 5) The d.c. electric vehicle supply equipment regulates the d.c. charging current responding to the change of command value of the vehicle.

b) CVC

- 1) The vehicle battery can be charged using CVC with the vehicle as master and the d.c. electric vehicle supply equipment as slave;
- 2) The d.c. electric vehicle supply equipment receives the charging voltage value the vehicle requested (command value) throughout the charging process;
- 3) The d.c. electric vehicle supply equipment sets the command value as control target, and regulate the d.c. charging voltage;
- 4) The command value from the vehicle is notified to the d.c. electric vehicle supply equipment at regular intervals according to the system requirements; and
- 5) The d.c. electric vehicle supply equipment regulates the d.c. charging voltage responding to the change of command value of the vehicle.

D-1.3.4 *Description of Process of Normal Shutdown*

After completion of the charging session, the normal shutdown phase allows the d.c. electric vehicle supply equipment to return to the conditions prior to charging. When the vehicle or d.c. electric vehicle supply equipment indicates the end of charging, the d.c. electric vehicle supply equipment reduces the charge current to zero. The vehicle side contactors open at near zero current. The d.c. electric vehicle supply equipment or the vehicle unlatches the vehicle connector only if the voltage at the inlet between d.c. + and d.c. - is less than 60 V d.c. (see 6.3.1 ).

ANNEX E

(Foreword)

COMMITTEE COMPOSITION

Electrotechnology in Mobility Sectional Committee ETD 51

<i>Organization</i>	<i>Representative (s)</i>
International Centre of Automotive Technology, Gurugram	SHRI PRASHANT VIJAY (<i>Chairperson</i>)
ABB India Limited, Bengaluru	SHRI VAIBHAV DESHWAL
Ador Digatron Private Limited, Pune	SHRI JAI PRAKASH SINGH SHRI PURUSHOTTAM EKANDE (<i>Alternate I</i>) SHRI PRASHANT DKHARADE (<i>Alternate II</i>)
Ashok Leyland Limited, Chennai	DR. SHANKAR AKELLA SHRI HUZEFA A. C. (<i>Alternate I</i>) SHRI SRINIVAS S. (<i>Alternate II</i>)
Ather Energy Private Limited, Bengaluru	SHRI SWAPNIL JAIN SHRI VIGNESH REVIRAJ (<i>Alternate</i>)
Autogrid India Private Limited, Bengaluru	SHRI VISH GANTI
Automotive Component Manufactures Association of India, New Delhi	SHRI SANJAY TANK MS POOJA SHARMA (<i>Alternate</i>)
Bajaj Auto Limited, Pune	SHRI MILIND JPAGARE SHRI ARVIND V. KUMBHAR (<i>Alternate</i>)
Bharat Test House Private Limited, New Delhi	SHRI VAIBHAV GUPTA
Bosch Limited, Bengaluru	SHRI PRADEEP RAMACHANDRA SHRI HARIPRASAD GOWRISANKAR (<i>Alternate I</i>) SHRI SANJAY KHATRI (<i>Alternate II</i>) MS VEENA KOODLI (<i>Alternate III</i>)
Calcutta Electric Supply Corporation Limited, Kolkata	SHRI RAJIB KUMAR DAS SHRI SANTANU SEN (<i>Alternate</i>)
Castus Energy Solutions Private Limited, Chennai	SHRI SIVAM SABESAN
Central Electricity Authority, New Delhi	MS SHIVANI SHARMA SHRI KULDEEP SINGH RANA (<i>Alternate I</i>) SHRIMATI VANDANA SINGHAL (<i>Alternate II</i>) MS SEEMA SAXENA (<i>Alternate III</i>)
CG Power and Industrial Solutions, Mumbai	SHRI A. SUDHAKARAN SHRI SANDEEP R. BACHKAR (<i>Alternate</i>)
CSIR - National Physical Laboratory, New Delhi	SHRI R. P. ALOYSIUS MS PRIYANKA JAIN (<i>Alternate</i>)
Delta Electronics India Private Limited, Haryana	SHRI ROHIT DALAL SHRI SHASHANK NARAYAN (<i>Alternate</i>)

IS 17017 (Part 30) : 2024

<i>Organization</i>	<i>Representative (s)</i>
Denso International India Private Limited, Gurugram	SHRI ALOK KUMAR
Department of Science and Technology, New Mehrauli Road, New Delhi	SHRI SURESH BABU MUTTANA
Dialogue and Development Commission of Delhi Delhi	SHRI ASHOK KUMAR JHA
Eaton India Innovation Center, Pune	SHRI SUKUMAR DE SHRI DILEEP KUMAR CHENI (<i>Alternate</i>)
Enphase Energy, Bengaluru	SHRI SHREEJA KUMAR NAIR SHRI SAGAR BOSE (<i>Alternate</i>)
Esmito Solutions Private Limited, Chennai	DR PRABHJOT KAUR
Exicom Tele-Systems Limited, Gurugram	SHRI P. M. SINGH SHRI ABHIJEET KUMAR (<i>Alternate</i>)
Fortum India Private Limited, Gurugram	SHRI AWADHESH KUMAR JHA SHRI CHINMAY SHUKLA (<i>Alternate I</i>) SHRI ANKIT MAHESHWARI (<i>Alternate II</i>)
Hero Motocorp Limited, New Delhi	SHRI FERAZ ALI KHAN SHRI PIYUSH CHOWDHRY (<i>Alternate I</i>) SHRI VARUN KUMAR SHARMA (<i>Alternate II</i>)
Honda Cars India Research and Development Limited, Noida	SHRI KOJI TAMENORI SHRI SURAJ AGARWAL (<i>Alternate I</i>) SHRI S. MUTHU KUMAR (<i>Alternate II</i>) SHRI KARAN RAJPUT (<i>Alternate III</i>)
India Smart Grid Forum, New Delhi	SHRI REJI KUMAR PILLAI SHRI ANAND SINGH (<i>Alternate I</i>) SHRI ALEKHYA VADDIRAJ (<i>Alternate II</i>)
India Yamaha Motor Private Limited, Noida	SHRI SANJEEV CHUGH SHRI J. EMMANUEL (<i>Alternate</i>)
Indian Electrical and Electronics Manufacturers Association, New Delhi	SHRI KUMAR RAHUL SHIJOY VARUGHESE (<i>Alternate I</i>) SHRI UTTAM KUMAR (<i>Alternate II</i>)
Indian Institute of Technology Bombay, Mumbai	SHRI SANDEEP ANAND DR NARENDRA SHIRADKAR (<i>Alternate I</i>) SHRI ZAKHIR RATHER (<i>Alternate II</i>) MS ANITHA DHIANESHWAR (<i>Alternate III</i>)
Infineon Technologies India Private Limited, Noida	SHRI SANJAY PARAB
International Advanced Research Centre for Powder Metallurgy and New Materials, Gurugram	DR TATA NARASINGA RAO DR SRINIVASAN ANANDAN (<i>Alternate</i>)
International Centre of Automotive Technology, Manesar	SHRIMATI VIJAYANTA AHUJA

<i>Organization</i>	<i>Representative (s)</i>
International Copper Association India, Mumbai	SHRI DEBDAS GOSWAMI SHRI HEMANTH KUMAR (<i>Alternate I</i>) SHRI MAYUR KARMAKAR (<i>Alternate II</i>)
JBM Group, Gurugram	SHRI MANOJ GUPTA SHRI OHIT MALHOTRA (<i>Alternate</i>)
L&T Electrical & Automation, Mumbai	SHRI C. S. KORE KEDAR R. PURANDARE (<i>Alternate</i>)
Mahindra Electric Mobility Limited, Bengaluru	SHRI GURURAJ RAVI
Maruti Suzuki India Limited, Gurugram	MS BUVANESWARI M. SHRI SUMIT KUMAR (<i>Alternate II</i>)
Mass Tech Controls Private Limited, Mumbai	SHRI ANURAG S. PATIL SHRI SUBHASH N. PATIL (<i>Alternate I</i>) SHRI BHUSHAN BHARAMBE (<i>Alternate II</i>)
Matter Motor Works Private Limited, Ahmedabad	DR PRASHANT JAIN DR AKKARAPAKA ANANADA KUMAR (<i>Alternate</i>)
Ministry of Electronics and Information Technology, New Delhi	SHRI OM KRISHAN SINGH SHRI RENJI V. CHACKO (<i>Alternate</i>)
Ministry of Heavy Industries and Public Enterprises, New Delhi	SHRI A.A DESHPANDE SHRI ABHIJIT MULAY (<i>Alternate I</i>) SHRI M. M. DESAI (<i>Alternate II</i>)
Ministry of Road Transport and Highways, New Delhi	SHRI K. C. SHARMA MS JAYSHREE SAHOO (<i>Alternate</i>)
NarnixTechnolabs Private Limited, New Delhi	SHRI KISHOR N. NARANG
Nissan Motor India Private Limited, Chennai	SHRI KAZUHIKO HASHIDATE SHRI KULDEEPSINGH RAJ RANVIRSINH (<i>Alternate I</i>) SHRI PRADEESH RAJASUNDARAM (<i>Alternate II</i>)
NITI Aayog, New Delhi	SHRI RANDHEER SINGH
Ola Electric Technologies Private Limited, Bengaluru	SHRI SUBRAT KUMAR DASH SHRI ARAVIND KANNAN (<i>Alternate</i>)
Panasonic India Private Limited, Gurugram	SHRI ATUL ARYA SHRI SHAILESH KUMAR DUBEY (<i>Alternate I</i>) SHRI YOGESH KUMAR (<i>Alternate II</i>)
Phoenix Contact India Private Limited, New Delhi	SHRI AMIT TYAGI SHRI ALOK AGGARWAL (<i>Alternate I</i>) SHRI AMIT SHARMA (<i>Alternate II</i>)
Rajasthan Electronics and Instruments Limited, Bengaluru	SHRI RAKESH CHOPRA DR P. N. SHARMA (<i>Alternate</i>)

IS 17017 (Part 30) : 2024

<i>Organization</i>	<i>Representative (s)</i>
Reddy Automotive Private Limited (RACEnergy), Hyderabad	SHRI GAUTHAM M. SHRI ARUN SREYAS REDDY (<i>Alternate</i>)
Reliance BP Mobility Limited, New Delhi	SHRI SUSHANT GANGWAR SHRI ASHISH AGARWAL (<i>Alternate</i>)
Renault India Private Limited, Mumbai	SHRI RAJENDRA KHILE SHRI VIJAY DINAKARAN (<i>Alternate</i>)
RevosAutotech Private Limited, Bengaluru	SHRI ROHAN YAJURVEDI SHRI GNANESWAR IKKURTHI (<i>Alternate</i>)
Shakti Sustainable Energy Foundation, New Delhi	SHRI RUCHIR SHUKLA
Siemens Limited, Mumbai	SHRI BIDYUT MAZUMDER SHRI AMIT KEKARE (<i>Alternate</i>)
Society of Indian Automobile Manufacturers (SIAM), Delhi	SHRI PRASHANT KUMAR BANERJEE
Sun Mobility Private Limited, Bengaluru	SHRI KARTHIKEYAN S. SHRI SURAJ RAJU (<i>Alternate</i>)
Tata Motors Limited, Pune	SHRI CHANDAN SAWHNEY SHRI SURESH ARIKAPUDI (<i>Alternate I</i>) SHRI MAKARAND KUMBHAR (<i>Alternate II</i>)
Tata Power Delhi Distribution Limited, New Delhi	DR G. GANESH DAS SHRI YOGESH KUMAR(<i>Alternate</i>)
Tech Perspect Software Private Limited, Delhi	SHRI SUMIT AHUJA SHRI RAMESH ARORA (<i>Alternate I</i>) SHRI VISHAL SHARMA (<i>Alternate II</i>)
TE Connectivity India Private Limited, Bengaluru	SHRI SANJAY PATIL SHRI RAJESH ARAVIND (<i>Alternate</i>)
The Energy and Resources Institute, New Delhi	SHRI ALEKHYA DATTA DR SHASHANK VYAS (<i>Alternate I</i>) SHRI NESHWIN RODRIGUES (<i>Alternate II</i>)
Toyota Kirloskar Motor Private Limited, Bidadi	SHRI CHANNAPPA REVADI SHRI RAJU M. (<i>Alternate I</i>) SHRI M. SUCHINDRAN (<i>Alternate II</i>)
TVS Motor Company Limited, Hosur	SHRI M. S. ANANDKUMAR SHRI ASISH KUMAR DAS (<i>Alternate</i>)
UL India Private Limited, Bengaluru	SHRI V. MANJUNATH SHRI SRIPARN SAURABH (<i>Alternate</i>)
Valeo India Private Limited, Chennai Vision	SHRI VIVEKMURALI
Mechatronics Private Limited, Thane	DR RASHI GUPTA SHRI BHARAT GUPTA (<i>Alternate</i>)

<i>Organization</i>	<i>Representative (s)</i>
Volvo Group India Private Limited, Bengaluru	SHRI RAJESH D. SHRI ABHISHEK BANTHIA (<i>Alternate</i>)
In Personal Capacity (<i>506/2 Kirti Apartments, Mayur Vihar, Phase 1 Extension, Delhi 110091</i>)	SHRI P. K. MUKHERJEE
BIS Directorate General	MS PRITI BHATNAGAR, SCIENTIST 'F'/SENIOR DIRECTOR AND HEAD ELECTROTECHNICAL [REPRESENTING DIRECTOR GENERAL (<i>Ex-officio</i>)]

Member Secretary
SHRI RITWIK ANAND
SCIENTIST 'D'/JOINT DIRECTOR
(ELECTROTECHNICAL), BIS

Co-Member Secretary
SHRI NEERAJ KUSHWAHA
SCIENTIST 'B'/ASSISTANT DIRECTOR
(ELECTROTECHNICAL), BIS

Bureau of Indian Standards

BIS is a statutory institution established under the *Bureau of Indian Standards Act, 2016* to promote harmonious development of the activities of standardization, marking and quality certification of goods and attending to connected matters in the country.

Copyright

BIS has the copyright of all its publications. No part of these publications may be reproduced in any form without the prior permission in writing of BIS. This does not preclude the free use, in the course of implementing the standard, of necessary details, such as symbols and sizes, type or grade designations. Enquiries relating to copyright be addressed to the Head (Publication & Sales), BIS.

Review of Indian Standards

Amendments are issued to standards as the need arises on the basis of comments. Standards are also reviewed periodically; a standard along with amendments is reaffirmed when such review indicates that no changes are needed; if the review indicates that changes are needed, it is taken up for revision. Users of Indian Standards should ascertain that they are in possession of the latest amendments or edition by referring to the website-www.bis.gov.in or www.standardsbis.in.

This Indian Standard has been developed from Doc No.: ETD 51 (21658).

Amendments Issued Since Publication

Amend No.	Date of Issue	Text Affected

BUREAU OF INDIAN STANDARDS

Headquarters:

Manak Bhavan, 9 Bahadur Shah Zafar Marg, New Delhi 110002

Telephones: 2323 0131, 2323 3375, 2323 9402

Website: www.bis.gov.in

Regional Offices:

Central : 601/A, Konnectus Tower -1, 6th Floor,
DMRC Building, Bhavbhuti Marg, New
Delhi 110002

Telephones

{ 2323 7617

Eastern : 8th Floor, Plot No 7/7 & 7/8, CP Block, Sector V,
Salt Lake, Kolkata, West Bengal 700091

{ 2367 0012
2320 9474

Northern : Plot No. 4-A, Sector 27-B, Madhya Marg,
Chandigarh 160019

{ 265 9930

Southern : C.I.T. Campus, IV Cross Road, Taramani, Chennai 600113

{ 2254 1442
2254 1216

Western : 5th Floor/ MTNL CETTM Technology Street, Hiranandani Gardens,
Powai, Mumbai 400076

{ 2570 0030
2570 2715

Branches : AHMEDABAD, BENGALURU, BHOPAL, BHUBANESHWAR, CHANDIGARH, CHENNAI, COIMBATORE, DEHRADUN, DELHI, FARIDABAD, GHAZIABAD, GUWAHATI, HARYANA (CHANDIGARH), HUBLI, HYDERABAD, JAIPUR, JAMMU, JAMSHEDPUR, KOCHI, KOLKATA, LUCKNOW, MADURAI, MUMBAI, NAGPUR, NOIDA, PARWANOO, PATNA, PUNE, RAIPUR, RAJKOT, SURAT, VIJAYAWADA.