

विद्युत यांत्रिक प्राथमिक रिले  
भाग 10 उच्च क्षमता वाले रिले के लिए अतिरिक्त  
कार्यात्मक पहलू एवं सुरक्षा अपेक्षाएँ

**Electromechanical Elementary  
Relays**  
**Part 10 Additional Functional Aspects  
and Safety Requirements for High-  
Capacity Relays**

ICS 29.120.70

© BIS 2024

© IEC 2019



भारतीय मानक ब्यूरो

BUREAU OF INDIAN STANDARDS

मानक भवन, 9 बहादुर शाह ज़फर मार्ग, नई दिल्ली - 110002

MANAK BHAVAN, 9 BAHADUR SHAH ZAFAR MARG

NEW DELHI - 110002

[www.bis.gov.in](http://www.bis.gov.in) [www.standardsbis.in](http://www.standardsbis.in)

## NATIONAL FOREWORD

This Indian Standard (Part 10) which is identical to IEC 61810-10 : 2019 'Electromechanical elementary relays: Part 10 Additional functional aspects and safety requirements for high-capacity relays' issued by the International Electrotechnical Commission (IEC) was adopted by the Bureau of Indian Standards on the recommendation of the Power Systems Relays Sectional Committee and approval of the Electrotechnical Division Council.

This standard is published in several parts. The other parts in this series are:

Part 1	General and safety requirements
Part 2	Reliability
Part 3	Relays with forcibly guided (mechanically linked) contacts
Part 7	Test and measurement procedures

The text of the IEC standard has been approved as suitable for publication as an Indian Standard without deviations. Certain conventions are, however, not identical to those used in Indian Standards. Attention is particularly drawn to the following:

- Wherever the words 'International Standard' appears referring to this standard, they should be read as 'Indian Standard'; and
- Comma (,) has been used as a decimal marker, while in Indian Standards the current practice is to use a point (.) as the decimal marker.

In this standard, reference appears to International Standards for which Indian Standards also exist. The corresponding Indian Standards, which are to be substituted, are listed below along with their degree of equivalence for the editions indicated:

International Standard	Corresponding Indian Standard	Degree of Equivalence
IEC 60028 International standard of resistance for copper	IS 191 : 2007 Copper Specification ( <i>fourth revision</i> )	— Technically Equivalent
IEC 60060-1 : 2010 High-voltage test techniques — Part 1: General definitions and test requirements	IS 2071 (Part 1) : 2016/ IEC 60060-1 : 2010 High-voltage test techniques — Part 1: General definitions and test requirements ( <i>third revision</i> )	Identical
IEC 60068-2-17 Basic environmental testing procedures — Part 2-17: Tests — Test Q: Sealing	IS/IEC 60068-2-17 : 1994 Basic environmental testing procedures — Part 2-17: Tests — Test Q: Sealing	Identical
IEC 60068-2-27 Environmental testing — Part 2-27: Tests — Test Ea and guidance: Shock	IS 9000 (Part 7/Sec 1) : 2018/ IEC 60068-2-27 : 2008 Basic environmental testing procedures for electronic and electrical items: Part 7 Impact test, Section 1 Shock (test Ea) ( <i>second revision</i> )	Identical
IEC 60270 High-voltage test techniques — Partial discharge measurements	IS/IEC 60270 : 2000 High-voltage test techniques — Partial discharge measurements	Identical

[\(Continued on third cover\)](#)

## CONTENTS

1	Scope .....	1
2	Normative references .....	1
3	Terms and definitions .....	2
4	Influence quantities .....	3
5	Rated values .....	3
6	General provisions for testing .....	3
7	Documentation and marking .....	4
8	Heating.....	4
9	Basic operating function .....	6
10	Dielectric strength .....	7
11	Electrical endurance .....	9
12	Mechanical endurance.....	9
13	Clearances, creepage distances and solid insulation .....	9
14	Terminations .....	13
15	Sealing.....	13
16	Heat and fire resistance.....	14
17	Special tests.....	14
	Annex A (normative) Explanations regarding relays .....	15
	Annex B (informative) Inductive contact loads.....	16
	Annex C (normative) Test set-up .....	19
	Annex D (informative) Special loads .....	20
	Annex E (normative) Heating test arrangement.....	21
	Annex F (normative) Measurement of clearances and creepage distances.....	22
	Annex G (normative) Relation between rated impulse voltage, nominal voltage and overvoltage category .....	23
	Annex H (normative) Pollution degrees .....	25
	Annex I (normative) Proof tracking test .....	26
	Annex J (informative) Schematic diagram of families of terminations .....	27
	Annex K (normative) Glow-wire test .....	28
	Annex L (normative) Ball pressure test .....	29
	Annex M (informative) Needle flame test.....	30
	Annex N (informative) Resistance for standard soldering processes .....	31
	Annex O (informative) Risk assessment.....	32
	Annex P (informative) Mechanical properties of terminals .....	33
	Annex Q (normative) Long-term stability of the sealing (leak rate evaluation) .....	39
	Annex R (informative) Short-circuit capacity .....	41
	Annex S (informative) Special tests for applications – Photovoltaic systems .....	41
	Annex T (informative) Special tests for applications – Road vehicles .....	45
	Bibliography.....	54
	Figure 1 – Test procedure of system evaluation .....	13

Figure P.1 – Test equipment for flexion test .....	37
Figure Q.1 – Temperature cycle .....	39
Figure R.1 – Short-circuit capacity test circuit .....	42
Figure T.1 – Short voltage drop for system with nominal voltages .....	50
Figure T.2 – Supply voltage profile for the reset test .....	51
Figure T.3 – PSD of acceleration versus frequency .....	54
Figure T.4 – PSD of acceleration versus frequency .....	55
Table 1 – Type testing .....	4
Table 2 – Required relay data .....	4
Table 3 – Test conductor for test current above 400 A and up to 800 A inclusive dependent on the current carried by the terminal .....	6
Table 4 – Test copper bars for test current above 400 A and up to 1 000 A inclusive dependent on the current carried by the terminal .....	6
Table 5 – Dielectric strength – AC .....	7
Table 6 – Dielectric strength – DC .....	8
Table 7 – Minimum clearances in air for insulation coordination .....	10
Table B.1 – Verification of the making and breaking capacity (abnormal conditions) .....	16
Table B.2 – Verification of the making and breaking capacity (normal conditions) .....	17
Table B.3 – Electrical endurance test .....	18
Table G.1 – Correspondence between the nominal voltage of the supply system and the equipment rated impulse withstand voltage, in case of overvoltage protection by surge-arresters according to IEC 61810-1 .....	23
Table P.1 – Tightening torques for the verification of the mechanical strength of screw- type terminals .....	34
Table P.2 – Test values for flexion and pull-out tests for round copper conductors .....	36
Table P.3 – Test values for pull-out test for flat copper conductors .....	38
Table S.1 – Special tests for photovoltaic system .....	45
Table S.2 – Number of operating cycles .....	46
Table S.3 – Special tests .....	47
Table T.1 – Special test for road vehicles .....	48
Table T.2 – Supply voltage for $U_N = 12$ V system devices .....	52
Table T.3 – Supply voltage for $U_N = 24$ V system devices .....	52
Table T.4 – Values for PSD and frequency .....	54
Table T.5 – Values for PSD and frequency .....	55
Table T.6 – Values for PSD and frequency, additional test in case of natural frequencies, $f_n$ , of DUT below 30 Hz .....	56

*Indian Standard*

**ELECTROMECHANICAL ELEMENTARY RELAYS**  
**PART 10 ADDITIONAL FUNCTIONAL ASPECTS AND SAFETY**  
**REQUIREMENTS FOR HIGH-CAPACITY RELAYS**

**1 Scope**

This part of IEC 61810, with functional and safety aspects, applies to electromechanical elementary relays (non-specified time all-or-nothing relays) with high capability requirements like breaking or short circuit capabilities and similar for incorporation into low-voltage equipment. These relays may have a specific design to extinguish the electric arc between contacts (e.g. by magnetic blow-out), or use an insulation coordination not covered by IEC 61810-1 (e.g. by gas filled contact chambers), or require safety assessments not covered by IEC 61810-1 (e.g. for higher loads).

It defines additional requirements for high-capacity relays with generic performance intended for use in applications in smart grids, electric vehicles and other applications where, for example, battery charge/discharge switching is used, such as:

- electrical energy storage (EES) systems,
- solar photovoltaic energy systems,
- electric road vehicles (EV) and electric industrial trucks,
- power electronic systems and equipment,
- secondary cells and batteries,
- road vehicles.

Compliance with the requirements of this standard is verified by the type tests indicated.

**2 Normative references**

The following documents are referred to in the text in such a way that some or all of their content constitutes requirements of this document. For dated references, only the edition cited applies. For undated references, the latest edition of the referenced document (including any amendments) applies.

IEC 60028, *International standard of resistance for copper*

IEC 60060-1:2010, *High-voltage test techniques – Part 1: General definitions and test requirements*

IEC 60068-2-14, *Environmental testing – Part 2-14: Tests – Test N: Change of temperature*

IEC 60068-2-17, *Basic environmental testing procedures – Part 2-17: Tests – Test Q: Sealing*

IEC 60068-2-27, *Environmental testing – Part 2-27: Tests – Test Ea and guidance: Shock*

IEC 60068-2-64:2008, *Environmental testing – Part 2-64: Tests – Test Fh: Vibration, broadband random and guidance*

IEC 60270, *High-voltage test techniques – Partial discharge measurements*

IEC 60664-1:2007, *Insulation coordination for equipment within low-voltage systems – Part 1: Principles, requirements and tests*

IEC 60664-3:2016, *Insulation coordination for equipment within low-voltage systems – Part 3: Use of coating, potting or moulding for protection against pollution*

IEC 60947-1:2007, *Low-voltage switchgear and controlgear – Part 1: General rules*

IEC 60999-1, *Connecting devices – Electrical copper conductors – Safety requirements for screw-type and screwless-type clamping units – Part 1: General requirements and particular requirements for clamping units for conductors from 0,2 mm<sup>2</sup> up to 35 mm<sup>2</sup> (included)*

IEC 60999-2, *Connecting devices – Electrical copper conductors – Safety requirements for screw-type and screwless-type clamping units – Part 2: Particular requirements for clamping units for conductors above 35 mm<sup>2</sup> up to 300 mm<sup>2</sup> (included)*

IEC 61810-1:2015, *Electromechanical elementary relays – Part 1: General and safety requirements*

ISO 16750-1:2018, *Road vehicles – Environmental conditions and testing for electrical and electronic equipment – Part 1: General*

ISO 16750-2:2012, *Road vehicles – Environmental conditions and testing for electrical and electronic equipment – Part 2: Electrical loads*

### **3 Terms and definitions**

For the purposes of this document, the terms and definitions given in IEC 61810-1 and the following apply.

ISO and IEC maintain terminological databases for use in standardization at the following addresses:

- IEC Electropedia: available at <http://www.electropedia.org/>
- ISO Online browsing platform: available at <http://www.iso.org/obp>

NOTE In the text of this document, the term "relay" is used instead of "elementary relay" to improve the readability.

#### **3.5 Terms and definitions related to contacts**

*Addition to IEC 61810-1:2015:*

##### **3.5.23**

##### **polarity of contact**

indication of which terminal of a contact is to be connected to the positive supply and which to the negative

##### **3.5.24**

##### **arcing time**

<of a pole or a fuse> interval of time between the instant of the initiation of the arc in a pole or a fuse and the instant of final arc extinction in that pole or that fuse

[SOURCE: IEC 60050-441:1984, 441-17-37]

#### 4 Influence quantities

Clause 4 of IEC 61810-1 is applicable.

#### 5 Rated values

Clause 5 of IEC 61810-1 is applicable, except as follows.

##### 5.6 Electrical endurance

Recommended number of cycles: 1; 2; 5; 10; 20; 50; 100; 200; 500; 1 000; 2 000; 3 000; 5 000; 6 000; 10 000; 20 000; 25 000; 30 000; 50 000; 100 000; 200 000; 300 000; 500 000; etc.

##### 5.7 Frequency of operation

Recommended frequencies: 180/h; 360/h; 720/h; 900/h and multiples thereof.

0,05 Hz; 0,1 Hz; 0,2 Hz; 0,25 Hz and multiples thereof.

##### 5.8 Contact loads

a) Resistive loads, recommended values

Current: 0,1 A; 0,5 A; 1 A; 2 A; 3 A; 5 A; 6 A; 8 A; 10 A; 12 A; 16 A; 20 A; 25 A; 30 A; 35 A; 60 A; 100 A; 120 A; 150 A; 200 A; 300 A; 400 A; 600 A; 800 A; 1 000 A (AC/DC).

Voltage: 4,5 V; 5 V; 12 V; 24 V; 36 V; 42 V; 48 V; 110 V; 125 V; 230 V; 250 V; 300 V; 380 V; 400 V; 480 V; 500 V; 575 V; 600 V; 690 V; 1 000 V (AC/DC); 1 200 V DC; 1 500 V DC.

b) Recommended inductive loads: see Annex B.

c) Recommended capacitive loads: see Annex D of IEC 61810-1:2015.

#### 6 General provisions for testing

Clause 6 of IEC 61810-1 is applicable, except as follows.

Deviating from IEC 61810-1, the specimens shall be grouped in 8 inspection lots, and the related tests shall be taken from Table 1 of this document.

Table 1 of this document replaces Table 3 of IEC 61810-1:2015.

**Table 1 – Type testing**

Inspection lot	Tests	Clause	Additional references
1	Marking and documentation	7	IEC 60417
	Heating (all coil voltages)	8	IEC 60085
	Basic operating function (all coil voltages)	9	
2	Dielectric strength	10	
3	Electrical endurance (per contact load and contact material)	11	
4	Mechanical endurance	12	
5	Clearances, creepage distances and distances through solid insulation	13	IEC 60664-1
6	Insulation coordination evaluation as a system (if applicable)	13.6	IEC 60060-1
	Screw type terminals and screwless terminals (if applicable)	14.2	IEC 60999-1
	Flat quick-connect terminations (if applicable)	14.3	IEC 61210
	Solder terminals (if applicable)	14.4	IEC 60068-2-20
	Sockets (if applicable)	14.5	IEC 61984
	Alternative termination types (if applicable)	14.6	
	Sealing (if applicable)	15	IEC 60068-2-17
7	Heat and fire resistance	16	IEC 60695-2-10
8	Leaking test (sealed relay only)	Annex Q	IEC 60068-2-14
			IEC 60068-2-17
<p>NOTE The number of coil voltages in inspection lot 1 to be tested can be reduced under certain conditions explained in Clauses 8 and 9.</p> <p>Beside the defined minimum requirements, deviations of test conditions and procedures could be specified by the manufacturer in the inspection lot 8.</p>			

## 7 Documentation and marking

Clause 7 of IEC 61810-1:2015 is applicable with the additions given in Table 2 of this document.

**Table 2 – Required relay data**

N°	Data	Notes	Place of indication
2d	Coil polarity	N/A in case of non-polarized coil	Relay and/or catalogue or instruction sheet
3h	Classification of load and polarity of contacts	For DC only use: +, - For AC/DC use: +/~, -/~, ~	Relay and/or catalogue or instruction sheet
5l	Limited short circuit capacity	Specify the fuses or current limiting device (if applicable)	Catalogue or instruction sheet

## 8 Heating

Clause 8 of IEC 61810-1:2015 is applicable with the following changes/additions.



#### 8.4.4 Screw and screwless type terminals

The electrical interconnections between the relays are made with bare rigid conductors (= default, however the usage of flexible conductors is allowed if defined from the manufacturer; this shall be stated in the documentation and in the test report) in accordance with Table 10 of IEC 61810-1:2015 with a maximum of 400 A, and in accordance with Table 3 with a maximum of 800 A. The connections of the relay to the voltage or current source(s) are realized with flexible conductors in accordance with Table 10 of IEC 61810-1:2015 with a maximum of 400 A, and in accordance with Table 3 with a maximum of 800 A. The electrical interconnections between the relays are made with copper bars in accordance with Table 4 with a maximum of 1 000 A. Any fixture to hold the flexible-connected test samples in place is not allowed to have any impact on the results.

The temperature rise at the terminals shall not exceed 45 K. This may be verified without the temperature rise influence of the relay contacts and the coil (e.g. bridged or short-circuited or soldered relay contacts).

#### 8.4.5 Alternative termination types

The electrical interconnections between the relays are made with bare rigid conductors in accordance with Table 10 of IEC 61810-1:2015 with a maximum of 400 A, and in accordance with Table 3 with a maximum of 800 A. The connections of the relay to the voltage or current source(s) are realized with flexible conductors in accordance with Table 10 of IEC 61810-1:2015 with a maximum of 400 A, and in accordance with Table 3 with a maximum of 800 A. The electrical interconnections between the relays are made with copper bars in accordance with Table 4 with a maximum of 1 000 A.

The temperature rise at the terminals shall not exceed 45 K. This may be verified without the temperature rise influence of the relay contacts and the coil (e.g. bridged or short-circuited or soldered relay contacts).

#### 8.4.6 Sockets

The maximum steady-state temperature limits permissible for the connections between relay and socket as well as for the insulating materials of both relay and socket adjacent to the connection shall not be exceeded.

The electrical interconnections between the sockets are made with conductors in accordance with Table 10 of IEC 61810-1:2015 with a maximum of 400 A, and in accordance with Table 3 with a maximum of 800 A. The connections of the sockets to the voltage or current source(s) are realized with flexible conductors in accordance with Table 10 of IEC 61810-1:2015 with a maximum of 400 A, and in accordance with Table 3 with a maximum of 800 A.

The electrical interconnections between the sockets are made with copper bars in accordance with Table 4 with a maximum of 1 000 A.

The mounting distance between sockets shall be specified by the manufacturer.

**Table 3 – Test conductor for test current above 400 A and up to 800 A inclusive dependent on the current carried by the terminal**

Current carried by the terminal <sup>a</sup> A		Conductor <sup>b,c,d,e</sup>			
Above	Up to and including	Number	Size mm <sup>2</sup>	Number	Size kcmil
400	500	2	150	2	250
500	630	2	185	2	350
630	800	2	240	3	300

<sup>a</sup> The value of test current shall be greater than the first value in the first column and less than or equal to the second value in that column

<sup>b</sup> For convenience of testing and with the manufacturer's consent, smaller conductors than those given for a stated test current may be used.

<sup>c</sup> The tables give alternative sizes for conductors in the metric and AWG/kcmil system and for bars in millimetres and inches. Comparison between AWG/kcmil and metric sizes is given in Table 1 of IEC 60947-1:2007.

<sup>d</sup> Either of the two conductors specified for a given test current range may be used.

<sup>e</sup> When a dimension of a wire is not available, the next smallest available standard wire size shall be used.

<sup>f</sup> Minimum conductor length for testing is 1 400 mm .

NOTE This table is based on Table 10 of IEC 60947-1:2007.

**Table 4 – Test copper bars for test current above 400 A and up to 1 000 A inclusive dependent on the current carried by the terminal**

Current carried by the terminal <sup>a</sup> A		2 set copper bars <sup>b,c,d,e</sup>		
Above	Up to and including	Number	Dimension mm <sup>2</sup>	Dimension inches
400	500	2	30 × 5	1 × 0,250
500	630	2	40 × 5	1,25 × 0,250
630	800	2	50 × 5	1,5 × 0,250
800	1 000	2	60 × 5	2 × 0,250

<sup>a</sup> The value of test current shall be greater than the first value in the first column and less than or equal to the second value in that column

<sup>b</sup> For convenience of testing and with the manufacturer's consent, smaller conductors than those given for a stated test current may be used.

<sup>c</sup> Either of the two conductors specified for a given test current range may be used.

<sup>d</sup> Bars are assumed to be arranged with their long faces vertical. Arrangements with long faces horizontal may be used if specified by the manufacturer.

<sup>e</sup> Minimum conductor length for testing is 1 400 mm (including the length of flexible conductors).

<sup>f</sup> The tables give alternative sizes for bars in millimetres and inches.

NOTE This table is based on Table 11 of IEC 60947-1:2007.

## 9 Basic operating function

Clause 9 of IEC 61810-1:2015 is applicable.

## 10 Dielectric strength

Clause 10 of IEC 61810-1:2015 is applicable with the following changes/additions: Table 5 and Table 6 of this document replace Table 13 and Table 14 of IEC 61810-1:2015.

**Table 5 – Dielectric strength – AC**

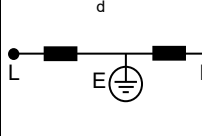
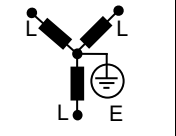
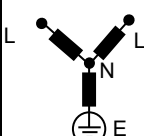
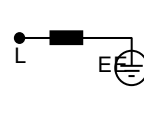
Insulation or disconnection to be tested <sup>g</sup>	Test voltage <sup>a b</sup> depending on the rated voltage of the circuit (RMS values)								
	<sup>c</sup> Up to and including 50 V	50 V to 120 V	100 V to 200 V 120 V to 240 V 125 V to 250 V	230 V / 400 V 277 V / 480 V	400 V / 400/ $\sqrt{3}$ V 480 V / 480/ $\sqrt{3}$ V	> 480 V			
									
	L – E	L – E	L – E	L – L	L – E	L – L	L – E	L – L	L – E
V	V	V		V		V			
Functional insulation <sup>h</sup>	500	1 300	1 300	1 500	1 500	1 700	1 700	1 700	$U_n + 1\,200\text{ V}$ (rounded)
Basic insulation <sup>i</sup>	500	1 300	1 300	---	1 500	---	1 700	---	$U_n + 1\,200\text{ V}$ (rounded)
Basic insulation (Test procedure B)	500	1 000 + 2 times rated voltage							
Supplementary insulation <sup>i</sup>	---	1 300	1 300	---	1 500	---	1 700	---	$U_n + 1\,200\text{ V}$ (rounded)
Reinforced or double insulation <sup>i</sup>	500	2 600	2 600	---	3 000	---	3 400	---	$2 \times (U_n + 1\,200\text{ V})$ (rounded)
Micro-disconnection <sup>j</sup>	400	400	400	500	500	700	700	700	$U_n + 250\text{ V}$
Full-disconnection	500	1 300	1 300	1 500	1 500	1 700	1 700	1 700	$U_n + 1\,200\text{ V}$ (rounded)

<sup>a</sup> The high-voltage transformer used for the test shall be designed so that, when the output terminals are short-circuited after the output voltage has been adjusted to the test voltage, the output current is at least 200 mA. The overcurrent relay shall not trip when the output current is less than 3 mA. Care shall be taken to ensure that the RMS value of the test voltage is measured within  $\pm 3\%$ .

<sup>b</sup> For functional, basic and supplementary insulation as well as for full disconnection, the values are derived from the formula  $U_n + 1\,200\text{ V}$  (rounded). The reinforced level from 50 V up is consequently two times higher.

For micro-disconnection, the values are derived from the formula  $U_n + 250\text{ V}$  (rounded), with  $U_n$  being the nominal voltage of the supply system.

<sup>c</sup> Up to and including 50 V: not to be connected direct to the supply mains. No temporary overvoltages in accordance with IEC 60364-4-44 are expected to occur.

<sup>d</sup> Single-phase system, mid-point earthed.

<sup>e</sup> Three-phase system, mid-point earthed.

<sup>f</sup> Three-phase system, one phase earthed.

<sup>g</sup> Special components which might render the test impractical such as light emitting diodes, free-running diodes, varistors are disconnected at one pole, or bridged, or removed, as appropriate to the insulation being tested.

<sup>h</sup> An example is the insulation between contacts necessary for proper function only.

<sup>i</sup> For the test of basic, supplementary and reinforced insulation, all live parts are connected together and care shall be taken to ensure that all moving parts are in the most unfavourable position.

<sup>j</sup> Contact gap ensuring proper function of the contact (covers also micro-interruption).

Table 6 – Dielectric strength – DC

Insulation or disconnection to be tested <sup>d</sup>	Test voltage <sup>a b</sup> depending on the rated voltage of the circuit						
	<sup>c</sup> Up to and including 50 V	Above 50 V up to including 120 V	120 V to 250 V 125 V to 250 V		240 V to 480 V		> 480V
	L – E	L – E	L – E	L – L	L – E	L – L	L – E
	V		V		V		
Functional insulation <sup>e</sup>	500	1 300	1 300	1 500	1 500	1 700	$U_n + 1\,200\text{ V}$ (rounded)
Basic insulation <sup>f</sup>	500	1 300	1 300	---	1 500	---	$U_n + 1\,200\text{ V}$ (rounded)
Basic insulation (Test procedure B)	500	1 000 + 2 times rated voltage					
Supplementary insulation <sup>f</sup>	---	1 300	1 300	---	1 500	---	$U_n + 1\,200\text{ V}$ (rounded)
Reinforced or double insulation <sup>f</sup>	500	2 600	2 600	---	3 000	---	$2 \times (U_n + 1\,200\text{ V})$ (rounded)
Micro-disconnection <sup>g</sup>	400	400	400	500	500	700	$U_n + 250\text{ V}$
Full-disconnection	500	1 300	1 300	1 500	1 500	1 700	$U_n + 1\,200\text{ V}$ (rounded)

<sup>a</sup> The high-voltage transformer used for the test shall be designed so that, when the output terminals are short-circuited after the output voltage has been adjusted to the test voltage, the output current is at least 200 mA. The overcurrent relay shall not trip when the output current is less than 3 mA. Care shall be taken that the value of the test voltage is measured within  $\pm 3\%$ .

<sup>b</sup> For functional, basic and supplementary insulation, as well as for full disconnection, the values are derived from the formula  $U_n + 1\,200\text{ V}$  (rounded). The reinforced level from 50 V up is consequently two times higher. For micro-disconnection, the values are derived from the formula  $U_n + 250\text{ V}$  (rounded), with  $U_n$  being the nominal voltage of the supply system.

<sup>c</sup> Up to and including 50 V: Not to be connected direct to the supply mains. No temporary overvoltages according to IEC 60364-4-44 are expected to occur.

<sup>d</sup> Special components which might render the test impractical such as light emitting diodes, free-running diodes, varistors are disconnected at one pole, or bridged, or removed, as appropriate to the insulation being tested.

<sup>e</sup> An example is the insulation between contacts necessary for proper function only.

<sup>f</sup> For the test of basic, supplementary and reinforced insulation, all live parts are connected together and care shall be taken to ensure that all moving parts are in the most unfavourable position.

<sup>g</sup> Contact gap ensuring proper function of the contact (covers also micro-interruption).

## 11 Electrical endurance

Clause 11 of IEC 61810-1:2015 is applicable with the following changes/additions.

### 11.1 General

If the relay has a defined polarity of a contact, the manufacturer shall specify an appropriate schematics for contact loading for the test, which may deviate from the schematics of Table 16 of IEC 61810-1:2015.

The heating test after the electrical endurance is mandatory if prescribed by the relevant product application annex of this document (e.g. Annex S for photovoltaic systems), or by application standards (e.g. IEC 60730-1 or IEC 60669-1).

### 11.2 Overload test

For the overload test, a number of cycles specified by the manufacturer is allowed.

### 11.3 Severity

The first detected temporary malfunction is defined as a failure (Severity A in accordance with 4.30.2 of IEC 61810-7:2006).

## 12 Mechanical endurance

Clause 12 of IEC 61810-1:2015 is applicable with Table 5 and Table 6.

## 13 Clearances, creepage distances and solid insulation

Clause 13 of IEC 61810-1:2015 is applicable with the following changes/additions.

### 13.1 General provisions

The first two sentences of this subclause of IEC 61810-1:2015 are deleted and replaced by:

The requirements and tests indicated in this clause are based on IEC 60664-1 and additionally allow the evaluation of the insulation evaluation as a system based on IEC 60060-1.

13.1.b) the third bullet point is changed as following:

- the partial discharge test under 5.8.5 of IEC 60664-3:2016 is required for peak voltages above 700 V;

### 13.2 Clearances and creepage distances

Table 18 of IEC 61810-1:2015 is replaced by the following Table 7.

**Table 7 – Minimum clearances in air for insulation coordination**

Impulse withstand voltage <sup>a</sup>	Minimum clearances up to 2 000 m above sea level <sup>c d</sup>		
	Pollution degree <sup>e</sup>		
	1	2	3
kV	mm	mm	mm
<b>0,33</b> <sup>b</sup>	0,01	0,2 <sup>c</sup>	0,8
0,40	0,02	0,2 <sup>c</sup>	0,8
<b>0,50</b> <sup>b</sup>	0,04	0,2 <sup>c</sup>	0,8
0,60	0,06	0,2	0,8
<b>0,80</b> <sup>b</sup>	0,10	0,2	0,8
1,0	0,15	0,2	0,8
1,2	0,25		0,8
<b>1,5</b> <sup>b</sup>	0,5		0,8
2,0	1,0		
<b>2,5</b> <sup>b</sup>	1,5		
3,0	2,0		
<b>4,0</b> <sup>b</sup>	3,0		
5,0	4,0		
<b>6,0</b> <sup>b</sup>	5,5		
<b>8,0</b> <sup>b</sup>	8,0		
10	11		
<b>12</b> <sup>b</sup>	14		
15 <sup>b</sup>	18		
18 <sup>b</sup>	22		
20 <sup>b</sup>	25		

- <sup>a</sup> This voltage is
- for basic insulation directly exposed to or significantly influenced by transient overvoltages from the low-voltage mains: the rated impulse voltage of the equipment;
  - for other basic insulation: the highest impulse voltage that can occur in the circuit;
  - for reinforced insulation, see footnotes a and b of Table 17 of IEC 61810-1:2015.
- In special cases, intermediate values derived by interpolation may be used for the dimensioning of clearances.
- <sup>b</sup> Preferred values for relating to the overvoltage category (see Annex G).
- <sup>c</sup> For printed wiring material, the values for pollution degree 1 apply except that the value shall not be less than 0,04 mm, as specified in Table 20 of IEC 61810-1:2015.
- <sup>d</sup> As the dimensions in Table 18 of IEC 61810-1:2015 are valid for altitudes up to and including 2 000 m above sea level, clearances for altitudes above 2 000 m are to be multiplied by the altitude correction factor specified in Table A.2 of IEC 60664-1:2007.
- <sup>e</sup> Details regarding pollution degrees are specified in Annex H of IEC 61810-1:2015.

### 13.3 Solid insulation

#### 13.3.1 General

Solid insulation shall be capable of durably withstanding electrical and mechanical stresses as well as thermal and environmental influences that may occur during the anticipated life of the relay.

The qualification of the solid insulation shall be verified by dielectric tests in accordance with 10.2 of IEC 61810-1:2015 based on the Tables 5 and 6, immediately after the preconditioning of 10.1 of IEC 61810-1:2015.

There is no dimensional requirement for the thickness of functional and basic insulation.

The basic insulation is always directly adjacent to the hazardous potential.

The distances through insulation for supplementary and reinforced insulation shall not be smaller than 1 mm.

NOTE The distance through insulation can however be reduced when the relevant IEC standard for specific equipment into which the relay is to be incorporated allows this.

Alternative to the solid insulation requirements above, supplementary or reinforced insulation could be realized with multilayer solutions and/or other minimum thicknesses as defined within other valid IEC standards (e.g. IEC 60065, IEC 60335, IEC 60730) and shall be described within the datasheet.

The requirement indicated above does not mean that the specified distance through insulation has to be achieved only by solid insulation. The insulation may comprise solid material and one or more air gaps.

This requirement, however, is not applicable where the insulation consists of thin layers, except for mica and similar scaling material, and if

- for supplementary insulation, the insulation consists of at least two layers, provided that each of the layers withstands the dielectric strength test of 10.2 of IEC 61810-1:2015 for supplementary insulation;
- for reinforced insulation, the insulation consists of at least three layers, provided that any two layers withstands the dielectric strength test of 10.2 of IEC 61810-1:2015 for reinforced insulation.

#### 13.3.2 Partial discharge

For components designed for more than 700 V peak the partial discharge can occur. The test in accordance with IEC 60664-1:2007, 6.1.3.5 shall be carried out to verify that no partial discharge occur. The test set-up shall be in accordance with C.1.2 of IEC 60664-1:2007. The factors  $F_1$  to  $F_4$  shall be applied, a partial discharge limit of 5pC shall be set,  $t_1$  shall be 5 s and  $t_2$  shall be 10s. The measurement shall be done with narrow banded test equipment in accordance with IEC 60270. If other conditions are applied on demand of the manufacturer, the deviations shall be noted in the test report.

The AC testing method is preferable. However, for specific DC dedicated designs with a polarized contact system, using the AC method can lead to wrong or failed results.

### 13.6 Insulation coordination evaluation as system

#### 13.6.1 General

Insulation systems where the IEC 60664 series does not or only partly apply, shall be evaluated in accordance with this clause. Typical example are gas-filled relays.

For such cases the evaluation shall be done in a manner similar to the statistic evaluation of IEC 60060-1.

### 13.6.2 Special procedure

The insulation coordination of gas-filled relays shall be evaluated according to the following. This procedure shall be applied for the evaluation of isolation between open contacts and can be applied for systems where insulation distances are composed of a part in air and another part where IEC 60664 does not apply.

In the case of compound insulation distances, at least one of the distances shall withstand the given insulation requirements. In cases where double or reinforced insulation is required, either one distance shall comply with the requirements of double or reinforced insulation, or each distance shall comply with the basic insulation requirement. In this case, the insulation system shall be evaluated in accordance with the requirements of 13.2 and 13.6, accordingly.

### 13.6.3 Condition

The principle conditions shall be given to apply this following procedure:

- the design shall be considered as partial-discharge free;
- the sealing has to be ensured for the product's lifetime;
- a possible flashover happens always between the contacts (clearance);
- the used test voltage shall be 1,2/50  $\mu$ s impulse voltage.

The dielectric strength of the complete design is defined with  $U_{50}^* - 3\sigma$  as the minimum dielectric strength of the system and shall be higher than the rated impulse withstand voltage in accordance with Table G.1. The altitude correction in accordance with Table F.5 of IEC 60664-1:2007 shall be used if applicable.

### 13.6.4 Test procedure

Evaluation of the fifty percent disruptive discharge voltage  $U_d^*$  shall be done in a manner similar to IEC 60060-1:2010, A.1.2.

- As the level of the first flashover is unknown in most cases, the increase method is recommended (see Figure 1 lower example).
- The increase or decrease of the pulse depends on the result of the previous shoot (see Figure 1 below, except that  $n = 1 \rightarrow$  voltage change after each shot). No breakdown of the solid insulation or via creepages are allowed.
- For each polarity, at least 100 shots (counter  $i$  is the number of accepted voltage levels, at least 2 voltage events shall be recorded to consider a voltage level as accepted) shall be carried out. For non-polarized contact systems, both directions have to be tested.

### 13.6.5 Data evaluation

The data evaluation follows IEC 60060-1:2010, A.3.2

The estimation of the calculated disruptive discharge voltage is calculated in accordance with

$$U_{50}^* = U_p^* = \sum_i \frac{k_i \times U_i}{m}$$

In accordance with IEC 60060-1:2010, Table A.1 and  $n = 1 \rightarrow p = 0,50$





## **16 Heat and fire resistance**

Clause 16 of IEC 61810-1 is applicable.

## **17 Special tests**

Special specifications for a relay for requirements requested by application standards or special applications are defined in Annex P, Annex R, Annex S and Annex T when specified by the manufacturer.

They state requirements where relays are specified by the manufacturer to perform their function under certain conditions different from normal service conditions as described in Clause 6.

Annex P states the test conditions and sequences and the results to be obtained when the manufacturer specifies increased strength requirements to terminals.

Annex R states the test conditions and sequences and the results to be obtained when the manufacturer specifies a short circuit capacity for the relay.

Annex S states applicable tests when the manufacturer specifies the relay as a relay for photovoltaic applications.

Annex T states applicable tests when the manufacturer specifies the relay as a relay for use in road vehicles.

As special tests, all these additional tests are not mandatory, and it is not required for a relay to satisfy any of these tests to conform to this document.

NOTE Specific requirements for such tests and further application driven requirements and consequently definitions are under investigation.

**Annex A**  
(normative)

**Explanations regarding relays**

Annex A of IEC 61810-1:2015 is applicable.

## Annex B (informative)

### Inductive contact loads

Annex B of IEC 61810-1:2015 is applicable, except the following amendments in Tables B.1, B.2 and B.3.

**Table B.1 – Verification of the making and breaking capacity (abnormal conditions)**

Classification	Making			Breaking			Number of cycles and frequency		
	$I/I_e$	$U/U_e$	$\cos \varphi$	$I/I_e$	$U/U_e$	$\cos \varphi$	Number of cycles	Frequency in cycles per minute	Duration of energization s
AC inductive load (contactor coil, solenoid valve)	10	1,1	0,3	10	1,1	0,3	10	6	0,04
	Total number of cycles						10		
	$I/I_e$	$U/U_e$	$T_{0,95}$	$I/I_e$	$U/U_e$	$T_{0,95}$	Number of cycles	Frequency in cycles per minute	Duration of energization
DC inductive load (contactor coil, solenoid valve)	1,1	1,1	$6 \times P^a$	1,1	1,1	$6 \times P^a$	10	6	$T_{0,95}$
	Total number of cycles						10		
	$I/I_e$	$U/U_e$	$T_{0,95}$	$I/I_e$	$U/U_e$	$T_{0,95}$	Number of cycles	Frequency in cycles per minute	Duration of energization
DC inductive load (shunt-motors, starting, plugging, inching, dynamic breaking of motors)	4	1,05	7,5 ms <sup>b</sup>	1,05	1,05	7,5 ms	1	6	0,2 s
	Total number of cycles						1		
$I_e$	Rated operating current					$I$	Switching current		
$U_e$	Rated operating voltage					$U$	Switching voltage		
$P = U_e \times I_e$	Steady-state power in W					$T_{0,95}$	Time to reach 95 % of the steady-state current in ms		
<sup>a</sup> The value " $6 \times P$ " is derived from an empirical relation appropriate for most of the DC inductive loads up to $P = 50$ W, where $6 \times P = 300$ ms. Loads with a rated power above 50 W comprise small loads in parallel. Therefore, 300 ms is an upper limit independent of the power value.									
<sup>b</sup> The inductive load in $P = U \times I > 50$ W and cannot do a typical classification, where $T_{0,95} = 7,5$ ms.									

**Table B.2 – Verification of the making and breaking capacity (normal conditions)**

Classification	Making			Breaking			Number of cycles and frequency		
	$I/I_e$	$U/U_e$	$\cos \varphi$	$I/I_e$	$U/U_e$	$\cos \varphi$	Number of cycles	Frequency in cycles per minute	Duration of energization s
AC inductive load (contactor coil, solenoid valve)	10	<sup>c</sup>	0,3	1	<sup>c</sup>	0,3	50	6	0,05
	10	1	0,3	1	1	0,3	10	> 60 <sup>b</sup>	0,05
	10	1	0,3	1	1	0,3	990	60	0,05
	10	1	0,3	1	1	0,3	5 000	6	0,05
	Total number of cycles						6 050		
	$I/I_e$	$U/U_e$	$T_{0,95}$	$I/I_e$	$U/U_e$	$T_{0,95}$	Number of cycles	Frequency in cycles per minute	Duration of energization
DC inductive load (contactor coil, solenoid valve)	1	<sup>c</sup>	$6 \times P^a$	1	<sup>c</sup>	$6 \times P^a$	50	6	$T_{0,95}$
	1	1	$6 \times P^a$	1	1	$6 \times P^a$	10	> 60 <sup>b</sup>	$T_{0,95}$
	1	1	$6 \times P^a$	1	1	$6 \times P^a$	990	60	$T_{0,95}$
	1	1	$6 \times P^a$	1	1	$6 \times P^a$	5 000	6	$T_{0,95}$
	Total number of cycles						6 050		
	$I/I_e$	$U/U_e$	$T_{0,95}$	$I/I_e$	$U/U_e$	$T_{0,95}$	Number of cycles	Frequency in cycles per minute	Duration of energization
DC inductive load (Shunt-motors, starting, plugging, inching, Dynamic breaking of motors)	4	1,05	7,5 ms <sup>d</sup>	1,5	1,05	7,5 ms <sup>d</sup>	As specified by the manufacturer	6	0,2 s
	4	1,05	7,5 ms <sup>d</sup>	1,05	1,05	7,5 ms <sup>d</sup>	As specified by the manufacturer	6	0,2 s
	Total number of cycles								
$I_e$	Rated operating current					$I$	Switching current		
$U_e$	Rated operating voltage					$U$	Switching voltage		
$P = U_e \times I_e$	Steady-state power in W					$T_{0,95}$	Time to reach 95 % of the steady-state current in ms		
<sup>a</sup> The value " $6 \times P$ " is derived from an empirical relation appropriate for most of the DC inductive loads up to $P = 50$ W, where $6 \times P = 300$ ms. Loads with a rated power above 50 W comprise small loads in parallel. Therefore, 300 ms is an upper limit independent of the power value. <sup>b</sup> With maximum permissible frequency (ensuring reliable making and breaking of the contacts). <sup>c</sup> The test is carried out at a voltage of $U_e \times 1,1$ , with the test current $I_e$ adjusted at $U_e$ . <sup>d</sup> The inductive load in $P = U \times I > 50$ W and cannot do a typical classification, where $T_{0,95} = 7,5$ ms.									

Table B.3 – Electrical endurance test

Current	Classification	Making			Breaking		
AC	inductive load (contactor coil, solenoid valve)	$I$	$U$	$\cos \varphi$	$I$	$U$	$\cos \varphi$
		$10 I_e$	$U_e$	$0,7^a$	$I_e$	$U_e$	$0,4^a$
DC <sup>b</sup>	inductive load (contactor coil, solenoid valve)	$I$	$U$	$T_{0,95}$	$I$	$U$	$T_{0,95}$
		$I_e$	$U_e$	$6 \times P^c$	$I_e$	$U_e$	$6 \times P^c$
DC <sup>b</sup>	inductive load (shunt-motors, starting, plugging, inching, dynamic breaking of motors)	$4 I_e$	$1,05 U_e$	$7,5 \text{ ms}^d$	$1,05 I_e$	$1,05 U_e$	$7,5 \text{ ms}^d$
$I_e$	Rated operating current			$I$	Switching current		
$U_e$	Rated operating voltage			$U$	Switching voltage		
$P = U_e \times I_e$	Steady-state power in W			$T_{0,95}$	Time to reach 95 % of the steady-state current in ms		
<p><sup>a</sup> The power factors indicated are conventional values and appear only in test circuits in which electrical characteristics of coils are simulated. Reference is made to the fact that for circuits with a power factor of 0,4 shunt resistors are used to simulate the damping effect due to eddy current losses.</p> <p><sup>b</sup> For DC inductive loads provided with a switching device to operate an economy resistor, the rated operating current shall be equal to at least the highest making current.</p> <p><sup>c</sup> The value "<math>6 \times P</math>" is derived from an empirical relation appropriate for most of the DC inductive loads up to <math>P = 50 \text{ W}</math>, where <math>6 \times P = 300 \text{ ms}</math>. Loads with a rated power above 50 W comprise small loads in parallel. Therefore, 300 ms is an upper limit independent of the power value.</p> <p><sup>d</sup> The inductive load in <math>P = U \times I &gt; 50 \text{ W}</math> and cannot do a typical classification, where <math>T_{0,95} = 7,5 \text{ ms}</math>.</p>							

**Annex C**  
(normative)

**Test set-up**

Annex C of IEC 61810-1:2015 is applicable.

**Annex D**  
(informative)

**Special loads**

Annex D of IEC 61810-1:2015 is applicable.



**Annex E**  
(normative)

**Heating test arrangement**

Annex E of IEC 61810-1:2015 is applicable.

**Annex F**  
(normative)

**Measurement of clearances and creepage distances**



Annex F of IEC 61810-1:2015 is applicable.

**Annex G**  
(normative)

**Relation between rated impulse voltage, nominal voltage and overvoltage category**

This Table G.1 replaces Table G.1 of IEC 61810-1:2015:

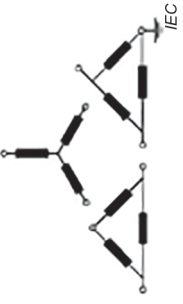
**Table G.1 – Correspondence between the nominal voltage of the supply system and the equipment rated impulse withstand voltage, in case of overvoltage protection by surge-arresters according to IEC 61810-1**

Maximum value of rated operational voltage to earth	Nominal voltage of the supply system <sup>a</sup> ( $\leq$ rated insulation voltage of the equipment)				Preferred values of rated impulse withstand voltage (1,2/50 $\mu$ s) at 2 000 m kV			
	 AC RMS V	 AC RMS V	 AC RMS or DC V	 AC RMS or DC V	Overvoltage category			
					IV Origin of installation (service entrance) level	III Distribution circuit level	II Load (appliance, equipment) level	I Specially protected level
50	–	–	12,5, 24, 25 30, 42, 48	60 to 30	1,5	0,8	0,5	0,33
100	66/115	66	60	–	2,5	1,5	0,8	0,5
150	120/208 127/220	115, 120 127	110, 120	220 to 110, 240 to 120	4	2,5	1,5	0,8
300	220/380, 230/400 240/415, 260/440 277/480	200, 220, 230 240, 260 277	220	440 to 220	6	4	2,5	1,5
600	347/600, 380/660 400/690, 415/720 480/830	347, 380, 400 415, 440, 480 500, 577, 600	480	960 to 480	8	6	4	2,5
1 250	–	660, 690, 720 830, 1 000	1 000	–	12	8	6	4
1 500					15	12	8	6
2 000					18	15	12	8
3 000 <sup>b</sup>					20	18	15	12

<p>Remark: The descriptions of overvoltage categories below are for information. The actual overvoltage category to be considered has to be taken from the product standard defining the application of the relay.</p>	
Overvoltage category I	Applies to equipment intended for connection to fixed installations of buildings, but where measures have been taken (either in the fixed installation or in the equipment) to limit transient overvoltages to the level indicated.
Overvoltage category II	Applies to equipment intended for connection to fixed installations of buildings.
Overvoltage category III	Applies to equipment in fixed installations, and for cases where a higher degree of availability of the equipment is expected.
Overvoltage category IV	Applies to equipment intended for use at or near the origin of the installation, from the main distributor towards the supply mains.
a	In accordance with IEC 60038.
b	For DC only.
c	For unearthed or impedance-earthed three-phase three-wire systems and single-phase two-wire systems, use the line-to-line voltage. For three-phase four-wire systems and for single-phase three-wire systems, use the line-to-neutral voltage. For a product or for equipment, use the rated insulation voltage when specified and otherwise the highest rated voltage. For an installation in a supply system, use the highest continuous voltage. If the highest continuous voltage is not more than 10 % higher than the nominal voltage, the nominal voltage may be used.

**Annex H**  
(normative)

**Pollution degrees**

Annex H of IEC 61810-1:2015 is applicable.

**Annex I**  
(normative)

**Proof tracking test**

Annex I of IEC 61810-1:2015 is applicable.

**Annex J**  
(informative)

**Schematic diagram of families of terminations**

Annex J of IEC 61810-1:2015 is applicable.

**Annex K**  
(normative)

**Glow-wire test**

Annex K of IEC 61810-1:2015 is applicable.



**Annex L**  
(normative)

**Ball pressure test**

Annex L of IEC 61810-1:2015 is applicable.

**Annex M**  
(informative)

**Needle flame test**

Annex M of IEC 61810-1:2015 is applicable.

**Annex N**  
(informative)

**Resistance for standard soldering processes**

Annex N of IEC 61810-1:2015 is applicable.

**Annex O**  
(informative)

**Risk assessment**

Annex O of IEC 61810-1:2015 is applicable.

## Annex P (informative)

### Mechanical properties of terminals

#### P.1 General

This annex on the testing of mechanical properties of terminals is based on IEC 60947-1. Terminals constructional requirements are as follows.

All parts of terminals that maintain contact and carry current shall be of metal having adequate mechanical strength.

Terminal connections shall be such that the conductors may be connected by means of screws, springs or other equivalent means so as to ensure that the necessary contact pressure is maintained.

Terminals shall be so constructed that the conductors can be clamped between suitable surfaces without any significant damage either to conductors or terminals. Terminals shall not allow the conductors to be displaced or be displaced themselves in a manner detrimental to the operation of equipment and the insulation voltage shall not be reduced below the rated values. If required by the application, terminals and conductors may be connected by means of cable lugs for copper conductors only.

NOTE 1 Examples of overall dimensions of terminal lugs suitable to be directly connected to the stud terminals of equipment are given in Annex P of IEC 60947-1.

Examples of terminals are given in Annex D of IEC 60947-1:2007. The requirements of this subclause shall be verified by the tests of P.2, P.3 and P.4, as applicable.

NOTE 2 North American countries have particular requirements for terminals suitable for aluminium conductors and marking to identify the use of aluminium conductors.

#### P.2 Mechanical strength of terminals

##### P.2.1 General

Unless otherwise stated by the manufacturer, each test shall be made on terminals in a clean and new condition. When tests are made with round copper conductors, these shall be of copper in accordance with IEC 60028. When tests are made with flat copper conductors, these shall have the following characteristics:

- minimum purity: 99,5 %;
- ultimate tensile strength: 200 N/mm<sup>2</sup> to 280 N/mm<sup>2</sup>;
- Vickers hardness: 40 to 65.

##### P.2.2 Procedure

Tests shall be made with the appropriate type of conductor having the maximum cross-sectional area. The conductor shall be connected and disconnected five times.

For screw-type terminals, the tightening torque shall be in accordance with Table P.1 or 110 % of the torque specified by the manufacturer, whichever is the greater. The test shall be conducted on two separate clamping units. Where a screw has a hexagonal head with means for tightening with a screwdriver and the values in columns II and III are different, the test is made twice, first applying to the hexagonal head the torque specified in column III, and then, on another set of samples, applying the torque specified in column II by means of a screwdriver. If the values in columns II and III are the same, only the test with the screwdriver

is made. Each time the clamping screw or nut is loosened, a new conductor shall be used for each tightening test.

**Table P.1 – Tightening torques for the verification of the mechanical strength of screw-type terminals**

Diameter of thread mm		Tightening torque N·m		
Metric standard values	Range of diameter	I	II	III
1,6	≤1,6	0,05	0,1	0,1
2,0	>1,6 up to and including 2,0	0,1	0,2	0,2
2,5	>2,0 up to and including 2,8	0,2	0,4	0,4
3,0	>2,8 up to and including 3,0	0,25	0,5	0,5
–	>3,0 up to and including 3,2	0,3	0,6	0,6
3,5	>3,2 up to and including 3,6	0,4	0,8	0,8
4,0	>3,6 up to and including 4,1	0,7	1,2	1,2
4,5	>4,1 up to and including 4,7	0,8	1,8	1,8
5	>4,7 up to and including 5,3	0,8	2,0	2,0
6	>5,3 up to and including 6,0	1,2	2,5	3,0
8	>6,0 up to and including 8,0	2,5	3,5	6,0
10	>8,0 up to and including 10,0	–	4,0	10,0
12	>10 up to and including 12	–	–	14,0
14	>12 up to and including 15	–	–	19,0
16	>15 up to and including 20	–	–	25,0
20	>20 up to and including 24	–	–	36,0
24	>24	–	–	50,0

Column I applies to screws without heads which, when tightened, do not protrude from the hole, and to other screws which cannot be tightened by means of a screwdriver with a blade wider than the root diameter of the screw.

Column II applies to nuts and screws which are tightened by means of a screwdriver.

Column III applies to nuts and screws which can be tightened by means other than a screwdriver.

### P.2.3 Requirements

During the test, clamping units and terminals shall not work loose and there shall be no damage, such as breakage of screws or damage to the head slots, threads, washers or stirrups that will impair the further use of the screwed connections.

## P.3 Flexion test (testing for damage to and accidental loosening of conductors)

### P.3.1 General

The test applies to terminals for the connection of unprepared round copper conductors, of number, cross-section and type (flexible and/or rigid (stranded and/or solid)), specified by the manufacturer.

NOTE An appropriate test for flat copper conductors can be made by agreement between the manufacturer and the user.

### P.3.2 Procedure

The following tests shall be carried out using two new samples with

- a) the maximum number of conductors of the smallest cross-section connected to the terminal;
- b) the maximum number of conductors of the largest cross-section connected to the terminal;
- c) the maximum number of conductors of the smallest and largest cross-sections connected to the terminal.

Terminals intended for connection of either flexible or rigid (solid and/or stranded) conductors shall be tested with each type of conductor with different sets of samples.

Terminals intended for connection of both flexible or rigid (solid and/or stranded) conductors simultaneously shall be tested as stated in c) above.

The test is to be carried out with suitable test equipment. The specified number of conductors shall be connected to the terminal. The length of the test conductors should be 75 mm longer than the height  $H$  specified in Table P.2. The clamping screws shall be tightened with a torque in accordance with Table P.1 or with the torque specified by the manufacturer. The device tested shall be secured as shown in Figure P.1.

**Table P.2 – Test values for flexion and pull-out tests  
for round copper conductors**

Conductor cross-section		Diameter of bushing hole <sup>a, b</sup>	Height $H^a$	Mass	Pulling force
mm <sup>2</sup>	AWG/kcmil				
		mm	mm	kg	N
0,2	24	6,5	260	0,2	10
0,34	22	6,5	260	0,2	15
0,5	20	6,5	260	0,3	20
0,75	18	6,5	260	0,4	30
1,0	—	6,5	260	0,4	35
1,5	16	6,5	260	0,4	40
2,5	14	9,5	280	0,7	50
4,0	12	9,5	280	0,9	60
6,0	10	9,5	280	1,4	80
10	8	9,5	280	2,0	90
16	6	13,0	300	2,9	100
25	4	13,0	300	4,5	135
—	3	14,5	320	5,9	156
35	2	14,5	320	6,8	190
—	1	15,9	343	8,6	236
50	0	15,9	343	9,5	236
70	00	19,1	368	10,4	285
95	000	19,1	406	14	351
—	0000	19,1	368	14	427
120	250 kcmil	22,2	406	14	427
150	300 kcmil	22,2	406	15	427
185	350 kcmil	25,4	432	16,8	503
—	400 kcmil	25,4	432	16,8	503
240	500 kcmil	28,6	464	20	578
300	600 kcmil	28,6	464	22,7	578

<sup>a</sup> Tolerances: for height  $H \pm 15$  mm, for diameter of the bushing hole  $\pm 2$  mm.

<sup>b</sup> If the bushing hole diameter is not large enough to accommodate the conductor without binding, a bushing having the next larger hole size may be used.



Dimensions in millimetres

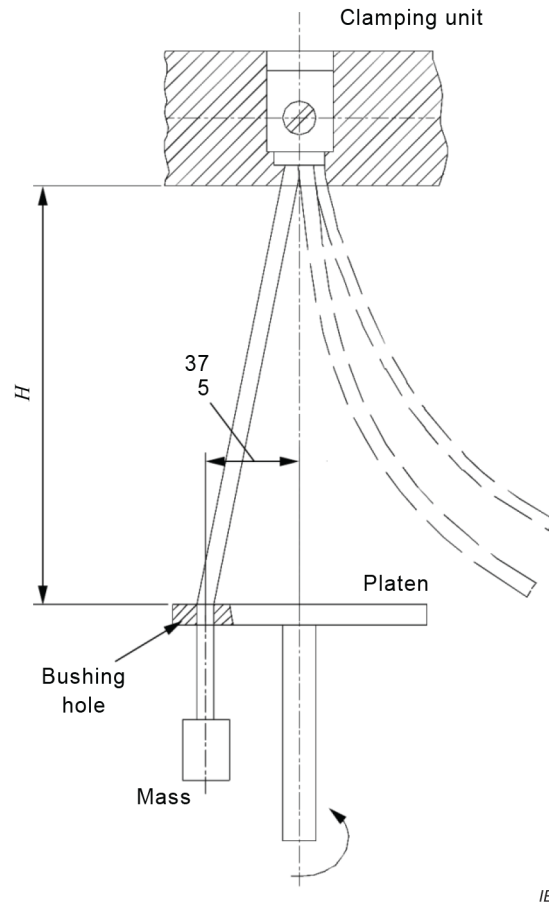

IEC

**Figure P.1 – Test equipment for flexion test**

Each conductor is subjected to circular motions in accordance with the following procedure:

The end of the conductor under test shall be passed through an appropriate size bushing in a platen positioned at a height  $H$  below the equipment terminal, as given in Table P.2. The other conductors shall be bent in order not to influence the result of the test. The bushing shall be positioned in the horizontal platen concentric with the conductor. The bushing shall be moved so that its centreline describes a circle of 75 mm diameter about its centre in the horizontal plane at  $10 \text{ r/min} \pm 2 \text{ r/min}$ . The distance between the mouth of the terminal and the upper surface of the bushing shall be within 15 mm of the height  $H$  in Table P.2. The bushing is to be lubricated to prevent binding, twisting or rotation of the insulated conductor. A mass as specified in Table P.2 is to be suspended from the end of the conductor. The test shall consist of 135 continuous revolutions.

### **P.3.3 Requirements**

During the test, the conductor shall neither slip out of the terminal nor break near the clamping unit.

Immediately after the flexion test, each conductor under test shall be submitted in the test equipment to the pull-out test.

## P.4 Pull-out test

### P.4.1 General

Immediately after the flexion test, each conductor under test shall be submitted in the test equipment to the pull-out test.

### P.4.2 Procedure

Following the rules of the flexion test, the pulling force given in Table P.2 for round copper conductors or Table P.3 for flat copper conductors shall be applied to the conductor tested in accordance with the flexion test.

The clamping screws shall not be tightened again for this test. The force shall be applied without jerks for 1 min.

**Table P.3 – Test values for pull-out test for flat copper conductors**

<b>Maximum width of flat conductors</b> mm	<b>Pulling force</b> N
12	100
14	120
16	160
20	180
25	220
30	280

### P.4.3 Requirements

During the test, the conductor shall neither slip out of the terminal nor break near the clamping unit.

## Annex Q (normative)

### Long-term stability of the sealing (leak rate evaluation)

#### Q.1 General

This test applies where the sealing is needed to ensure the proper functionality/safety and specified parameter.

NOTE This test applies where the operational properties of the relay depend on an internal gas chamber (e.g. contact chamber) with specific properties (e.g. evacuated volume, gas-filled volume).

The test shall be carried out for RT IV or RT V requirements. Where applicable, the relevant gas chamber shall be tested separately. The leaking test is based on IEC 60068-2-14 and Clause 15 of IEC 61810-1:2015.

#### Q.2 Procedure

##### Q.2.1 Pre-conditioning

The relays shall to be subjected to temperature cycling in accordance with IEC 60068-2-14, test Nb, consisting of 50 cycles, each cycle consisting of 1 hour ( $t_1$ ) at  $-40\text{ }^\circ\text{C}$  ( $T_A$ ) followed by 1 hour ( $t_1$ ) at  $+85\text{ }^\circ\text{C}$  ( $T_B$ ) as shown in Figure Q.1. Temperature change rate shall be 1 K/min.

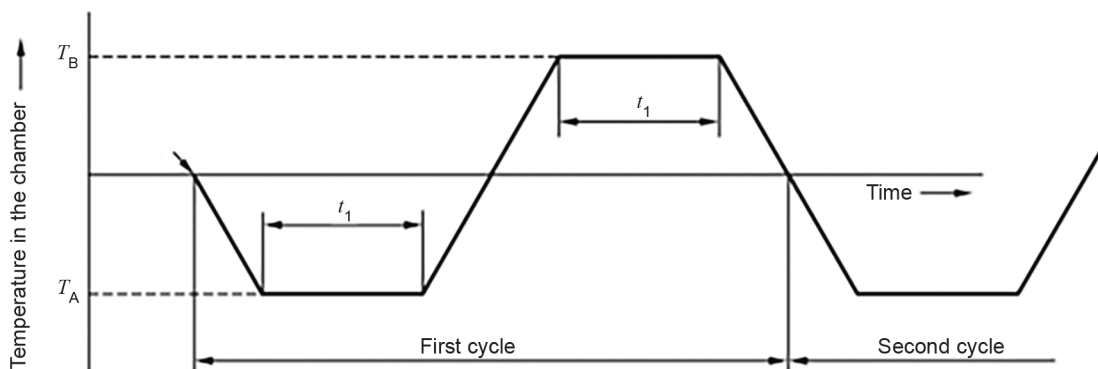

IEC

Figure Q.1 – Temperature cycle

A higher rate of change may be used if the temperature measured on relay terminals reaches  $-37\text{ }^\circ\text{C}$  at ambient  $-40\text{ }^\circ\text{C}$  or  $+82\text{ }^\circ\text{C}$  at ambient  $+85\text{ }^\circ\text{C}$  before the end of the one hour exposure time ( $t_1$ ).

At the conclusion of the 50 cycles, the relays shall be returned to room temperature of  $(25 \pm 5)\text{ }^\circ\text{C}$  for a minimum of 3 h.

##### Q.2.2 Evaluation

- Relay technology according to IEC 61810-1:2015 Table 2 shall be verified
- Visual inspection
- Verification of basic operating function in accordance with Clause 9.
- Heating test in accordance with Clause 8.

e) Dielectric strength in accordance with Clause 10.

NOTE Alternative procedure (electric arc discharge between contacts) is under consideration.

**Q.2.3 Requirements**

- a) The relay technology shall be as specified by the manufacturer
- b) No distortion or damage to parts that will affect normal operation and protection.
- c) The relay shall fulfill the requirements of Clause 5.3, 5.4 or 5.5 of IEC 61810-1:2015 as applicable
- d) The requirements of Clause 8 of IEC 61810-1: 2015 apply
- e) The requirements of Clause 10 of IEC 61810-1: 2015 apply

## Annex R (informative)

### Short-circuit capacity

#### R.1 General

The relay under test shall be in a new and clean condition, mounted as in service or specified by the manufacturer. The test arrangement is shown in Figure R.1. The details of the specified short-circuit protective device shall be stated by the manufacturer.

The test shall be performed under the reference conditions given in Clause 4 of IEC 61810-1.

The coil of the relay under test shall be energized at the nominal voltage, unless otherwise stated by the manufacturer.

The power source shall fulfil the following minimum requirements:

- $Z_s < \frac{1}{4} Z_L$  for AC
- $R_s < \frac{1}{4} R_L$  for DC

NOTE 1 The load impedance  $Z_L$  and the load resistance  $R_L$  includes the circuit wiring to the power supply terminals.

NOTE 2  $Z_s$  is the power source impedance;  $R_s$  is the power source resistance measured until the power supply terminals.

The wiring of the short circuit shall have at least the cross-section for the nominal current in accordance with Table 10 of IEC 61810-1:2015 and with Table 3 and Table 4 of this document. In the case that the resistance of the short circuit loop is too high to reach the requested short-circuit current, a higher cross-section shall be chosen.

The short-circuit protective device (SCPD) of the power source (including the primary and secondary protective devices) shall ensure that the short-circuit prospective current could flow uninfluenced at least four half waves for AC or 20 ms for DC for the calibration shot.

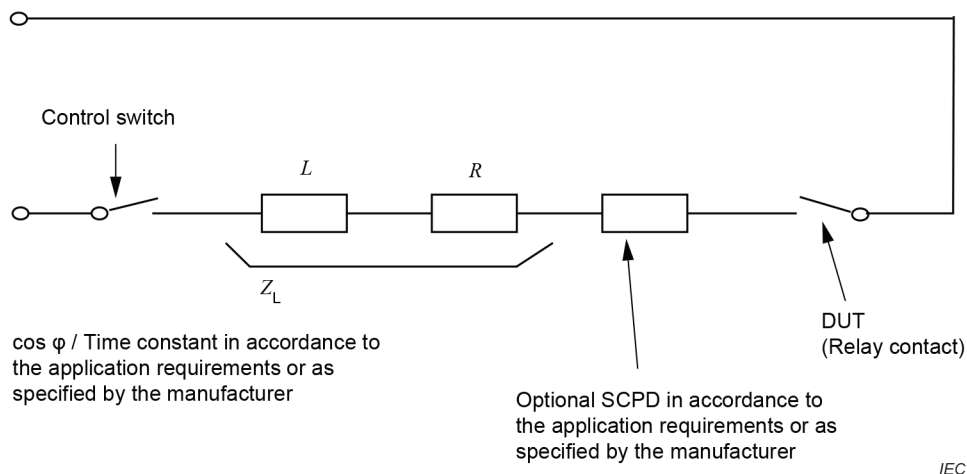

$Z_L$ : Impedance  
 $L$ : Inductance  
 $R$ : Resistance

The values shall be specified by the manufacturer.

NOTE 1 SCPD is short-circuit protective device (e.g. fuse). The cut-off could be more sensitive than the main SCPD (defined by the application or by the manufacturer).

NOTE 2 Measuring the arcing time could be helpful information for the relay manufacturer.

**Figure R.1 – Short-circuit capacity test circuit**

## R.2 Procedure

### R.2.1 General

The relay shall endure the stress generated from the short-circuit current under the conditions specified by the manufacturer.

### R.2.2 Preconditioning

The relay may be preconditioned several times (if any) before the test, at no load or at any current not exceeding the rated current. The preconditioning (if any) shall be mentioned in the test record.

### R.2.3 Test circuit calibration

For the circuit's calibration, the device under test (DUT) shall be bridged as close as possible to the DUT. However the bridge shall have the same length and cross-section as the bridged wiring path.

The current form has to be recorded and shall be part of the test record.

### R.2.4 Test procedure and/or sequence

The procedure and/or sequence shall be selected in accordance with the application. However the DUT shall be operated and monitored in accordance with Figure C.2 of IEC 61810-1:2015.

Examples for typical sequences:

- SCPD is used:
  - DUT make into fault condition, SCPD breaks

- DUT is closed, make is carried out by making switch, SCPD breaks
- No SCPD is present
  - DUT is closed, make and break is carried out by making switch for a specific time
  - DUT make into fault condition, break is carried out by making switch for a specific time
  - DUT is closed, make is carried out by making switch, break is carried out by DUT after a specific time
- DUT has SCPD functions
  - DUT make into and break fault condition
  - DUT is closed, make is carried out by making switch, DUT with SCPD function break

And maybe combinations of these.

Unless otherwise specified, the device shall withstand at least 3 times the requirement. For each test, a new sample could be used.

### **R.3 Requirements**

After the short-circuit capacity test, the relay shall satisfy the requirements stated by the manufacturer or the application standard:

If basic insulation is required, the dielectric test in accordance with 11.4 is required.

### **R.4 Test conditions**

The manufacturer specifies the following conditions:

- number of test samples;
- energization conditions: if other than the rated coil voltage;
- polarity of contact;
- test voltage;
- test current;
- short-circuit current time;
- failure criteria;
- test sequence;
- test set-up in general.

The test conditions shall be mentioned in the test record. If the test conditions are valid for all products/applications, then the test conditions shall be added to the datasheet/specification.

## **Annex S** (informative)

### **Special tests for applications – Photovoltaic systems**

#### **S.1 General**

This annex applies to electromechanical elementary relays intended for use with photovoltaic (PV) systems, and hereafter referred to as "PV relays".

PV relays used in PV systems are subjected to electrical, environmental and operational conditions that differ from the general conditions taken into account in the body of this document.

The requirements have thus been adapted to reflect these conditions of use.

The object of this annex is to state:

- the requirements for PV relays to be used on the DC side of PV applications and for disconnection on the AC side;
- the tests intended to verify the product performance when used under the environmental conditions expected in PV systems.

#### **S.2 Insulation coordination**

The rated impulse withstand voltage shall comply with the requirements for overvoltage category II in accordance with Annex G of IEC 61810-1.

In the case of requirement for full disconnection, the altitude of the PV system shall be considered in accordance with Table 7.

#### **S.3 Product marking**

Clause 7 applies with the following additions:

An elementary relay rated for use not only in PV applications shall have the ratings and short-circuit information in accordance with this annex clearly separated from the ratings in accordance with the body of this document.

A PV relay shall have method and diagram of series connection of poles (as necessary for each rating) marked under the conditions of item 3.h) of Table 2 and 5.e) of Table 6 of IEC 61810-1:2015.

#### **S.4 Performance requirements – Electrical endurance**

Clause 11 applies with the following two modifications:

Overload conditions do not arise in PV applications and could only result from short circuits. Therefore, no overload tests are required.

The heating test after the electrical endurance test shall be performed under the conditions of Clause 8.



## S.5 Type testing

### S.5.1 General

In general, Table 1 applies. The additional tests shown in Table S.1 shall be performed.

**Table S.1 – Special tests for photovoltaic system**

Test no.	Test	Reference standards of test conditions	Sample size	Acceptable number of failures	Performance requirements
S.5.2	Short circuit test	Annex R as informative with S.5.2 specifications	3	0	As specified by Manufacturer
S.5.3	Critical DC load current test	S.5.3	3	0	As specified by Manufacturer
S.5.4	Climatic test	IEC 60068-2-30, Test Db S.5.4	3	0	As specified by manufacturer
S.5.5	Special tests – salt mist, vibration and shock	IEC 60068-2-52, Test Kb IEC 60068-2-6, Test Fc IEC 60068-2-27, Test Ea	3	0	As specified by manufacturer

### S.5.2 Short-circuit test

The manufacturer shall specify the conditions for the short-circuit current limits. The test shall be carried out in accordance with Annex R.

After the short-circuit test, a heating test shall be performed under the conditions of Clause 8.

A visual inspection shall confirm that there is no distortion or damage to parts that will affect normal operation and protection.

The verification of basic operating function in accordance with Clause 9 shall be performed.

The dielectric withstand shall be verified in accordance with Clause 10.

### S.5.3 Critical DC load current test

This test applies to DC ratings only.

The test setup, comprising three samples, shall be in accordance with Clause 11 and with Annex C and Annex E of IEC 61810-1:2015.

The test shall be made at the maximum operational DC voltage and also with a battery fitted with a fault current protection device or without battery as defined by the manufacturer.

The PV relay shall be operated 10 times at each of the test currents listed below. If the direction of current flow is specified by the manufacturer (polarized relay), the test shall be carried out with the current flowing in the specified direction, as indicated by the polarity and line/load marking; if not, 5 operations shall be made in the forward direction, and 5 operations in the reverse direction.

During each operation cycle, the PV relay shall remain closed for a time sufficient to ensure that the full current is established, but not exceeding 2 s, unless otherwise specified by the manufacturer.

Unless otherwise specified by the manufacturer, the time constant of 1 ms shall be in accordance with Table 11 of IEC60947-2:2016 as for operational performance; at the discretion of the manufacturer, a higher value may be used, in which case this value shall be stated in the test report.

The number of operating cycles per hour shall be in accordance with Table S.2.

The arcing time during the test shall be recorded and shall not exceed 1 s.

The test current values shall be: 4 A, 8 A, 16 A, 32 A and 63 A DC, with  $\pm 10\%$  tolerance, but less than the rated current; the critical value is determined by taking the maximum mean arcing time, for each direction of current if applicable. The highest and lowest values of test current shall demonstrate shorter mean arcing times than the critical value; if necessary, the range of test currents shall be extended upwards or downwards by applying a 2 times ratio as many times as necessary, up to, but not exceeding, the rated current to find the critical value. If no critical value of current is found within these criteria, no further test in accordance with this subclause is required.

Following this test, the same sample shall be subjected to an operational performance verification of 50 operations, under the same conditions, at the current and in the direction corresponding to the critical value, if applicable 100 operations instead of 50, unless otherwise specified by the manufacturer.

After this test, the dielectric withstand shall be verified according to 11.4 of IEC 61810-1 with a corresponding DC test voltage.

**Table S.2 – Number of operating cycles**

Rated current <sup>a</sup>	Number of operating cycles per hour <sup>b</sup>	Number of operating cycles		
		Without current	With current <sup>c</sup>	Total
$I_n \leq 100$	120	9 700	300	10 000
$100 < I_n \leq 315$	120	7 800	200	8 000
$315 < I_n \leq 630$	60	4 800	200	5 000
$630 < I_n \leq 2 500$	20	2 900	100	3 000
$2 500 < I_n$	10	1 900	100	2 000

<sup>a</sup> This means the maximum rated current for a given frame size.

<sup>b</sup> Column 2 gives the minimum operating rate. This rate may be increased with the consent of the manufacturer; in this case, the rate used shall be stated in the test report.

<sup>c</sup> During each operating cycle, the PV relay shall remain closed for a sufficient time to ensure that the full current is flowing, but not exceeding 2 s.

#### **S.5.4 Climatic test**

The relays shall be subjected to the damp heat test in accordance with IEC 60068-2-30, test Db, 2 cycles at 40 °C, variant 2.

After the test, the samples shall be stored at standard atmospheric conditions for a minimum of 3 hours' recovery.

A visual inspection is carried out to confirm that there is no distortion or damage to parts that will affect normal operation and protection.

The verification of basic operating function in accordance with Clause 9 shall be performed.

The dielectric strength shall be verified in accordance with Clause 10 (excluding 10.1 of IEC 61810-1:2015).

At the discretion of the manufacturer, this test may be combined with the thermal cycling test (see Annex Q) and carried out on the same samples.

### **S.5.5 Special tests – Salt mist, vibration and shock**

The special tests of Table S.3 shall be made at the discretion of the manufacturer. As special tests, these additional tests are not mandatory, and it is not necessary for a relay to satisfy any of these tests to conform to this document.

**Table S.3 – Special tests**

<b>Test</b>	<b>Reference standards of test conditions</b>	<b>Performance requirements</b>
Salt mist	IEC 60068-2-52, Test Kb	As defined by the manufacturer including severity level
Vibration	IEC 60068-2-6, Test Fc	As defined by the manufacturer
Shock	IEC 60068-2-27, Test Ea	As defined by the manufacturer

## Annex T (informative)

### Special tests for applications – Road vehicles

#### T.1 General

These special tests are for the qualification of elementary relays in certain applications as listed here after. They are based on application-specific standards like ISO 16750-1:2018, ISO 16750-2:2012, IEC 60947-1:2007, or others.

For the tests of T.2.8 and T.2.9, the manufacturer shall define if such test is to be conducted on the relay itself or on the equipment where the relay is mounted.

#### T.2 Road vehicles

##### T.2.1 General

Table T.1 defines the applicable tests, test conditions, performance requirements, sample size and acceptable number of failures for the application in road vehicles.

**Table T.1 – Special test for road vehicles**

Test no.	Test	Reference standards of test conditions	Sample size	Acceptable number of failures	Performance requirements
T.2.2	Momentary drop in supply voltage	4.6.1 of ISO 16750-2:2012	1	0	Class B of ISO 16750-1:2018
T.2.3	Reset behaviour at coil voltage drop	4.6.2 of ISO 16750-2:2012	1	0	Class C of ISO 16750-1:2018
T.2.4	Coil overvoltage	4.3.1.1 and 4.3.2.1 of ISO 16750-2:2012	1	0	Class C of ISO 16750-1:2018
T.2.5	Slow decrease and increase of supply voltage	4.5 of ISO 16750-2:2012	1	0	Class D or Class C of ISO 16750-1:2006
T.2.6	Electrical endurance	Clause 11 of IEC 61810-1:2015	1	0	Clause 11 of IEC 61810-1:2015
T.2.7	Acoustic noise	4.44 of IEC 61810-7:2006	1	0	As specified by the manufacturer
T.2.8	Vibration	4.1.2.4 and 4.1.2.6 of ISO 16750-3:2012; 4.28 of IEC 61810-7:2006	1	0	Class A or Class C of ISO 16750-1:2006 for test according to ISO 16750-3 or T.2.8.1.3 T.2.8.2.3
T.2.9	Shock	4.1.2.2 of ISO 16750-3: 2012; 4.26 of IEC 61810-7:2006	1	0	Class A of ISO 16750-1:2006 for test according to ISO 16750-3 or T.2.9.4

NOTE Deviating sample sizes can be specified by the manufacturer.

Terms used in this annex:

- Momentary drop in supply voltage is the voltage drop in coil power supply of a relay.
- $U_N$ : nominal voltage is the value used to describe the electrical system of a vehicle's supply voltage.

- $U_S$ : supply voltage of the electrical system of a vehicle that varies with the system load and the operating condition of the generator.
- $U_{Smin}$ : supply voltage minimum is the lowest supply voltage of the specified supply voltage range of the device under test (DUT) at which the DUT achieves performance class A.
- $U_{Smax}$ : supply voltage maximum is highest supply voltage of the specified supply voltage range of the DUT at which the DUT achieves performance class A. Test voltage voltage(s) applied to the DUT during a test

EXAMPLE  $U_A$  and  $U_B$

- $T_{min}$ : minimum operating temperature is minimum value of the ambient temperature at which the system/components can be operated.
- $T_{max}$ : maximum operating temperature is maximum value of the ambient temperature at which the system/components can be operated.

Definitions related to functional status classification (for this annex):

- class A: all functions of the relays perform as designed during and after the test.
- class B: all functions of the relays perform as designed during and after the test. However, one or more of them may go beyond the specified tolerance during the test. All functions return automatically to within normal limits after the test. Memory functions achieve class A.

NOTE The manufacturer specifies which functions of the relay will perform as designed during the test and which functions can be beyond the specified tolerance.

- class C: one or more functions of the relays do not perform as designed during the test, but return automatically to normal operation after the test.
- class D: one or more functions of the relays do not perform as designed during the test and do not return to normal operation after the test until the device/system is reset by a simple "operate/use" action.
- class E: one or more functions of the relays do not perform as designed during and after the test and cannot be returned to proper operation without repairing or replacing the device/system.

## T.2.2 Momentary drop in supply voltage

### T.2.2.1 Purpose

This test simulates the effect when a conventional fuse element melts in another circuit.

### T.2.2.2 Test method

The influence due to an instantaneous voltage drop is checked by another circuit connected to the same power supply as the relay coil.

Apply the test pulse (see Figure T.1) simultaneously to all relevant inputs (connections) of the DUT. The rise time and fall time shall be not more than 10 ms.

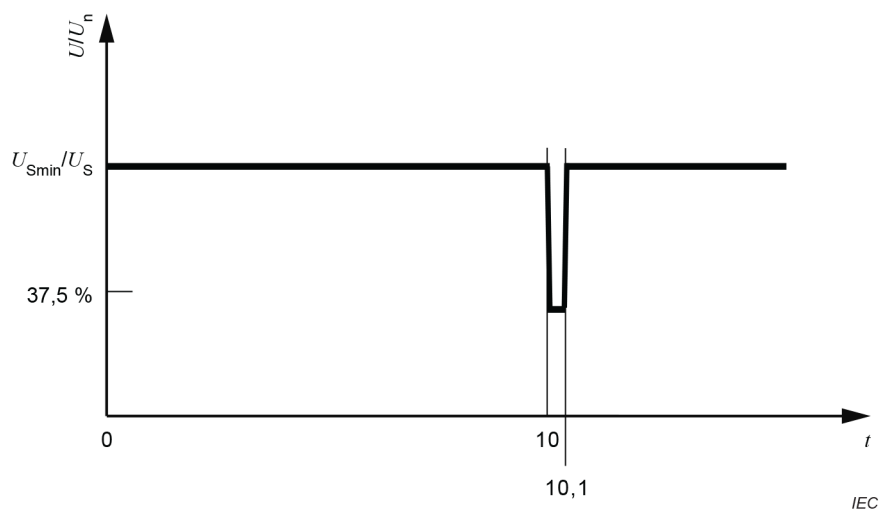

#### Key

$t$	time in seconds
$U$	test voltage in percentage
$U_n$	nominal voltage
$U_{Smin}$	minimum supply voltage

**Figure T.1 – Short voltage drop for system with nominal voltages**

#### T.2.2.3 Requirements

The functional status shall be minimum class B as specified in T.2.1. Reset is permitted upon specification of the manufacturer.

#### T.2.3 Reset behaviour at voltage drop

##### T.2.3.1 Purpose

This test verifies the reset behaviour of the DUT at different voltage drops. This test is applicable to equipment with reset function, for example, equipment containing microcontroller(s).

##### T.2.3.2 Test

Apply the test pulse simultaneously as shown in Figure T.2 to all relevant inputs (connections) and check the reset behaviour of the DUT.

Decrease the supply voltage by 5 % from the minimum supply voltage,  $U_{Smin}$ , to  $0,95 U_{Smin}$ . Hold this voltage for 5 s. Raise the voltage to  $U_{Smin}$ . Hold  $U_{Smin}$  for at least 10 s and perform a functional test. Then decrease the voltage to  $0,9 U_{Smin}$ . Continue with steps of 5 % of  $U_{Smin}$ , as shown in Figure T.2, until the lower value has reached 0 V. Then raise the voltage to  $U_{Smin}$  again.

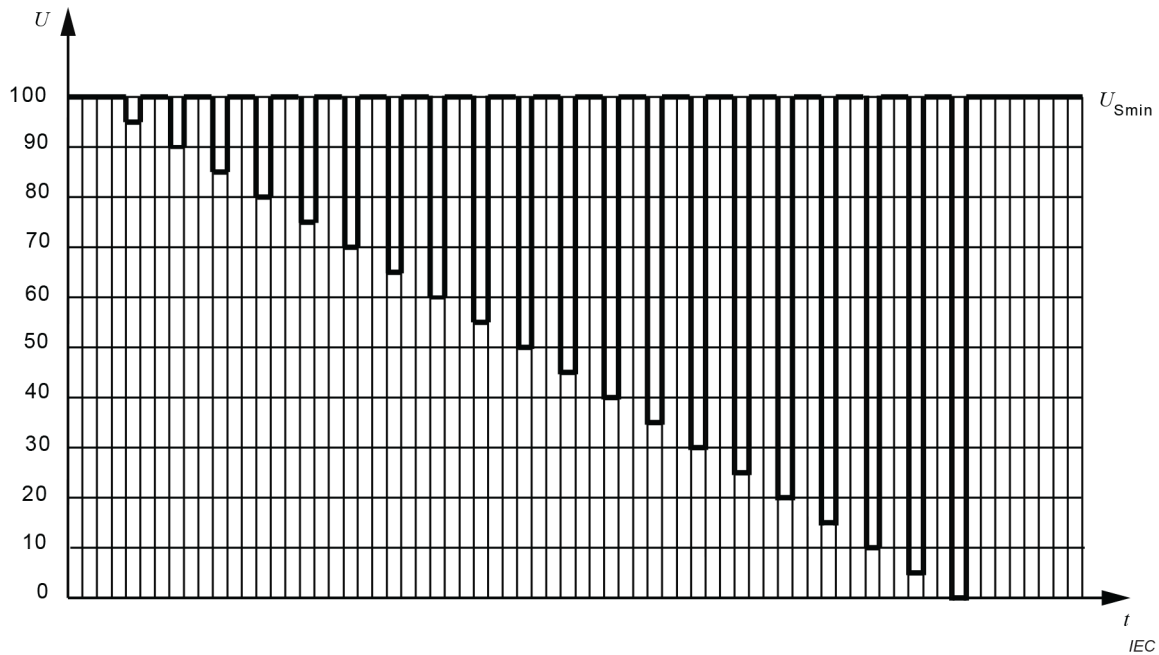

**Key**

- $t$  time in seconds
- $U$  test voltage measured as percentage of  $U_{Smin}$
- $U_{Smin}$  minimum supply voltage

**Figure T.2 – Supply voltage profile for the reset test**

**T.2.3.3 Requirements**

The functional status shall be at least class C as specified in T.2.1.

**T.2.4 Coil overvoltage**

**T.2.4.1 General**

In accordance with 4.3 of ISO 16750-2:2012, the tests of T.2.4.3 should be performed on systems with 12 V and 24 V nominal voltages.

**T.2.4.2 Purpose**

This test simulates the condition where the generator regulator fails, so that the output voltage of the generator rises above normal values.

**T.2.4.3 Test method**

Test at a temperature of  $T_{max} - 20$  °C.

Heat the DUT in an oven to a temperature that is 20 °C below the maximum operating temperature,  $T_{max}$ . Apply a voltage of  $(150 \% U_n \pm 0,2)$  V for 60 min  $\pm$  6 min to all relevant inputs of the DUT.

**T.2.4.4 Requirements**

The functional status for the DUT shall be at least class C as specified in T.2.1. Functional status shall be class A where more stringent requirements are necessary in accordance with ISO 16750-1.

## T.2.5 Slow decrease and increase of supply voltage

### T.2.5.1 General

In accordance with 4.5 of ISO 16750-2:2012, the test in T.2.5.3 should be performed on systems with 12 V and 24 V nominal voltages.

### T.2.5.2 Purpose

This test simulates a gradual discharge and recharge of the battery.

### T.2.5.3 Test

Apply the following test simultaneously to all applicable inputs (connections) of the DUT. Decrease the supply voltage from  $U_{Smin}$  to 0 V, then increase it from 0 V to  $U_{Smin}$ , applying a change rate of  $(0,5 \pm 0,1)$  V per minute.

### T.2.5.4 Requirements

The functional status inside the supply voltage range (Table T.2 or Table T.3) shall be as in 4.2.3 of ISO 16750-2:2012. Outside that range, it shall be at least class D as defined in ISO 16750-1. Functional status of class C may be specified where more stringent requirements are necessary.

**Table T.2 – Supply voltage for  $U_N = 12$  V system devices**

Code	Supply voltage (V)	
	$U_{Smin}$	$U_{Smax}$
A	6	16
B	8	16
C	9	16
D	10,5	16

**Table T.3 – Supply voltage for  $U_N = 24$  V system devices**

Code	Supply voltage (V)	
	$U_{Smin}$	$U_{Smax}$
E	10	32
F	16	32
G	22	32
H	18	32

## T.2.6 Electrical endurance

### T.2.6.1 Purpose

This test checks the electrical endurance of the relay contact when operating the relay repeatedly while carrying load current. The below conditions specify relevant tests for road vehicles. From the listed tests, product- and application-specific tests shall be selected for the qualification of the relay.

The test procedures are specified for:

- for continuous rated relays, e.g. relays intended for main charging of vehicles, and



- for short-time rated relays, e.g. for pre-charging applications.

The following terms are used for the purpose of this clause:

- the overload is the operating condition in an electrically undamaged circuit that causes an overcurrent (see 3.2.10);
- the capacity with reverse polarity interruption is the maximum current that a polarized contact block can break with reverse polarity interruption under specified conditions;
- the electrical endurance with rated current is the number of switching cycles under rated voltage and rated carrying current with load;
- the electrical endurance with maximum switching current is the number of breaking cycles at maximum switching current;
- the electrical endurance with overload interruption is the number of breaking cycles at maximum interruption current with DC overload;
- the electrical endurance with reverse polarity interruption is the number of breaking cycles at maximum interruption current with reverse polarity of DC load;
- the electrical endurance with inrush current is the number of switching cycles at rated inrush current.

#### **T.2.6.2 Test method**

The test procedures, the test conditions and the load conditions shall be selected in accordance with Clause 11.

The contacts shall be monitored to detect break and/or make malfunctions as well as unintended bridging.

The test set-up described in IEC 61810-1 shall be used.

The contacts are connected to the load(s) in accordance with Clause 11 of IEC 61810-1:2015 as specified by the manufacturer. If not otherwise specified by the manufacturer, the load shall be applied to both the make and break side of a change-over contact.

#### **T.2.6.3 Requirements**

Subclause 11.4 applies.

#### **T.2.7 Acoustic noise**

The test should be carried out in accordance with 4.44 of IEC 61810-7:2006 and as specified by the manufacturer in Table T.1.

#### **T.2.8 Vibration**

##### **T.2.8.1 General**

The test should be carried out in accordance with 4.28 of IEC 61810-7:2006 or another appropriate test method specified by manufacturer.

##### **T.2.8.2 Test I – Passenger car, sprung masses (vehicle body)**

###### **T.2.8.2.1 Purpose**

This test checks the DUT for malfunctions and breakage caused by vibration.

Vibration of the body is random vibration induced by rough-road driving. The main failure to be identified by this test is breakage due to fatigue.

NOTE Unless otherwise specified by the manufacturer, the following test conditions are only for the vehicle body.

**T.2.8.2.2 Test**

Perform the test in accordance with IEC 60068-2-64:2008, 8.4. Use a test duration of 8 h for each plane of the DUT. The RMS acceleration value shall be 27,1 m/s<sup>2</sup>. The PSD versus frequency is illustrated in Figure T.3 and Table T.4.

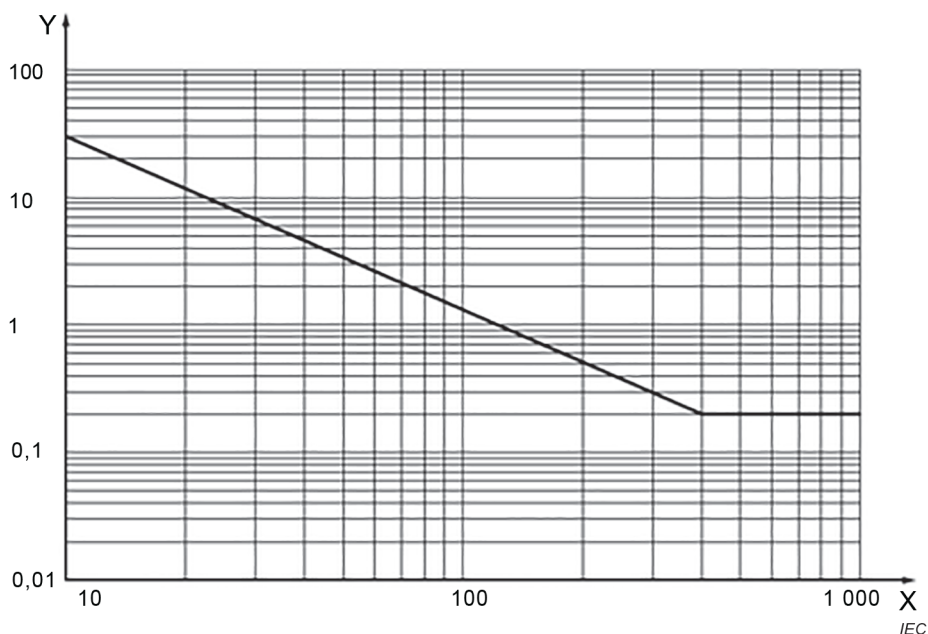

**Key**

- Y PSD [(m/s<sup>2</sup>)<sup>2</sup>/Hz]
- X Frequency (Hz)

**Figure T.3 – PSD of acceleration versus frequency**

**Table T.4 – Values for PSD and frequency**

Frequency (Hz)	PSD [(m/s <sup>2</sup> ) <sup>2</sup> /Hz]
10	30
400	0,2
1 000	0,2

**T.2.8.2.3 Requirements**

Breakage shall not occur.

As defined in ISO 16750-1, functional status class A is required during operating with electric operation and control in typical operating mode, and functional status class C during periods with other operating modes.

**T.2.8.3 Test II – Commercial vehicle, sprung masses**

**T.2.8.3.1 Purpose**

This test checks the DUT for malfunctions and breakage caused by vibration.

Vibration on sprung masses is random vibration induced by rough-road driving. The main failure to be identified by this test is breakage due to fatigue.

NOTE Unless otherwise specified by the manufacturer, the following test conditions are only for the vehicle body.

### T.2.8.3.2 Test

Perform the test in accordance with IEC 60068-2-64:2008, 8.4, using a test duration of 32 h for each plane of the DUT. The RMS acceleration value shall be 57,9 m/s<sup>2</sup>. The PSD versus frequency is illustrated to in Figure T.4 and Tables T.5 and T.6.

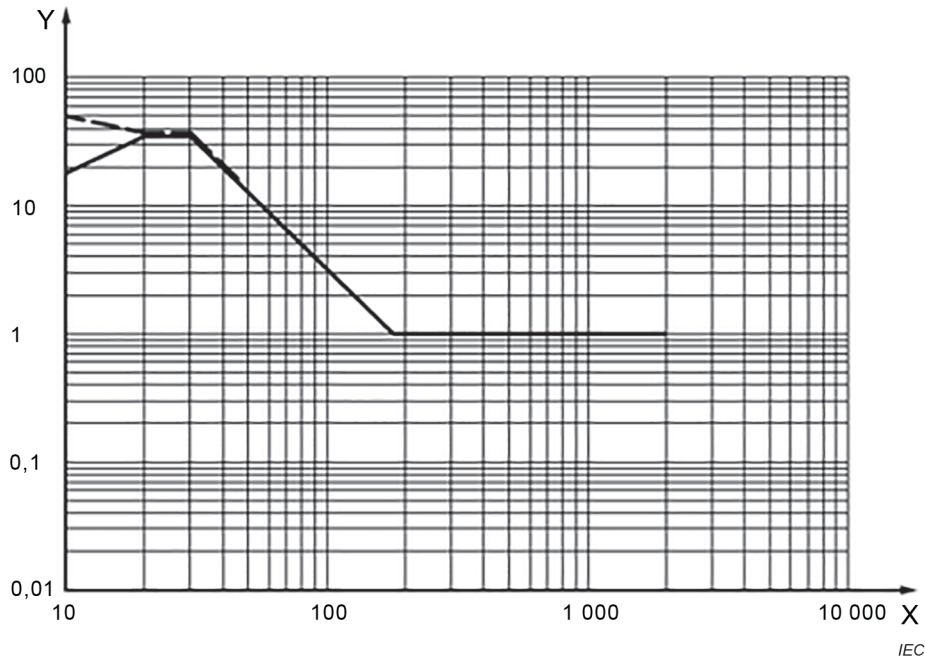

#### Key

Y PSD [(m/s<sup>2</sup>)<sup>2</sup>/Hz]

X Frequency (Hz)

— Standard random test profile

- - - Additional profile in case of  $f_n < 30$  Hz

Figure T.4 – PSD of acceleration versus frequency

Table T.5 – Values for PSD and frequency

Frequency (Hz)	PSD [(m/s <sup>2</sup> ) <sup>2</sup> /Hz]
10	18
20	36
30	36
180	1
2 000	1

NOTE RMS acceleration value = 57,9 m/s<sup>2</sup>

**Table T.6 – Values for PSD and frequency, additional test in case of natural frequencies,  $f_n$ , of DUT below 30 Hz**

Frequency (Hz)	PSD [(m/s <sup>2</sup> ) <sup>2</sup> /Hz]
10	50
20	36
30	36
45	16
NOTE RMS acceleration value = 33,7 m/s <sup>2</sup>	

### T.2.8.3.3 Requirements

Breakage shall not occur. As defined in ISO 16750-1, functional status class A is required during operating with electric operation and control in typical operating mode, and functional status class C during periods with other operating modes.

## T.2.9 Shock

### T.2.9.1 General

The test should be carried out in accordance with 4.26 of IEC 61810-7:2006 or another appropriate test method specified by the manufacturer.

### T.2.9.2 Purpose

This test checks the DUT for malfunctions and breakage caused by shock to body and frame.

The load occurs when driving over a curb stone at high speed, etc. Failure mode is mechanical damage (e.g. a detached capacitor inside the housing of an electronic control module due to the occurring high accelerations).

### T.2.9.3 Test

Perform the test in accordance with IEC 60068-2-27 using the following test parameters:

- operating mode of the DUT: with electric operation and control in typical operating mode;
- pulse shape: half-sinusoidal;
- acceleration: 500 m/s<sup>2</sup>;
- duration: 6 ms;
- number of shocks: 10 per test direction.

Acceleration due to the shock in the test shall be applied in the same direction that the acceleration of the shock occurs in the vehicle. If the direction of the effect is not known, the DUT shall be tested in each direction of three mutually perpendicular axes.

### T.2.9.4 Requirements

Breakage shall not occur. Functional status shall be class A as defined in ISO 16750-1.

## Bibliography

IEC 60038, *IEC standard voltages*

IEC 60050-441:1984, *International Electrotechnical Vocabulary (IEV) – Part 441: Switchgear, controlgear and fuses*

IEC 60060-1, *High-voltage test techniques – Part 1: General definitions and test requirements*

IEC 60068-2-20, *Environmental testing – Part 2-20: Tests – Test T: Test methods for solderability and resistance to soldering heat of devices with leads*

IEC 60085, *Electrical insulation – Thermal evaluation and designation*

IEC 60364-4-44, *Low-voltage electrical installations – Part 4-44: Protection for safety – Protection against voltage disturbances and electromagnetic disturbances*

IEC 60417, *Graphical symbols for use on equipment* (available at <http://www.graphical-symbols.info/equipment>)

IEC 60664 (all parts), *Insulation coordination for equipment within low-voltage systems*

IEC 60695-2-10, *Fire hazard testing – Part 2-10: Glowing/hot-wire based test methods – Glow-wire apparatus and common test procedure*

IEC 60947-2:2016, *Low-voltage switchgear and controlgear – Part 2: Circuit-breakers*

IEC 60947-5-1, *Low-voltage switchgear and controlgear – Part 5-1: Control circuit devices and switching elements – Electromechanical control circuit devices*

IEC 61210, *Connecting devices – Flat quick-connect terminations for electrical copper conductors – Safety requirements*

IEC 61810-7:2006, *Electromechanical elementary relays – Part 7: Test and measurement procedures*

IEC 61984, *Connectors – Safety requirements and tests*

ISO 16750-3:2012, *Road vehicles – Environmental conditions and testing for electrical and electronic equipment – Part 3: Mechanical loads*

---



(Continued from second cover)

International Standard	Corresponding Indian Standard	Degree of Equivalence
IEC 60664-1 : 2007 Insulation coordination for equipment within low-voltage systems — Part 1: Principles, requirements and tests	IS 15382 (Part 1) : 2022/ IEC 60644-1 : 2020 Insulation coordination for equipment within low-voltage systems: Part 1 Principles, requirements and tests ( <i>second revision</i> ) (Withdrawn) 	Identical with IEC 60664-1 : 2020
IEC 60664-3 : 2016 Insulation coordination for equipment within low-voltage systems — Part 3: Use of coating, potting or moulding for protection against pollution	IS 15382 (Part 3) : 2019/ IEC 60664-3 : 2016 Insulation coordination for equipment within low-voltage systems: Part 3 Use of coating, potting or moulding for protection against pollution ( <i>first revision</i> )	Identical with IEC 60664-3 : 2006
IEC 60947-1 : 2007 Low-voltage switchgear and controlgear — Part 1: General rules	IS/IEC 60947-1 : 2020 Low-voltage switchgear and controlgear: Part 1 General rules ( <i>second revision</i> )	Identical with IEC 60947-1 : 2020
IEC 61810-1 : 2015 Electromechanical elementary relays — Part 1: General and safety requirements	IS 17064 (Part 1) : 2018/ IEC 61810-1 : 2015 Electromechanical elementary relays: Part 1 General and safety requirements	Identical

The Committee has reviewed the provisions of the following international standards referred in this standard and decided that they are acceptable for use in conjunction with this standard.

<i>International Standard</i>	<i>Title</i>
ISO 16750-1 : 2018	Road vehicles — Environmental conditions and testing for electrical and electronic equipment — Part 1: General
ISO 16750-2 : 2012	Road vehicles — Environmental conditions and testing for electrical and electronic equipment — Part 2: Electrical loads
IEC 60068-2-14	Environmental testing — Part 2-14: Tests — Test N: Change of temperature
IEC 60068-2-64 : 2008	Environmental testing — Part 2-64: Tests — Test Fh: Vibration, broadband random and guidance
IEC 60999-1	Connecting devices — Electrical copper conductors — Safety requirements for screw-type and screwless-type clamping units — Part 1: General requirements and particular requirements for clamping units for conductors from 0,2 mm <sup>2</sup> up to 35 mm <sup>2</sup> (included)
IEC 60999-2	Connecting devices — Electrical copper conductors — Safety requirements for screw-type and screwless-type clamping units — Part 2: Particular requirements for clamping units for conductors above 35 mm <sup>2</sup> up to 300 mm <sup>2</sup> (included)

Only the English language text has been retained while adopting it in this Indian Standard, and as such, the page numbers given here are not the same as in the IEC publication.

For the purpose of deciding whether a particular requirement of this standard is complied with the final value, observed or calculated expressing the result of a test or analysis shall be rounded off in accordance with IS 2 : 2022 'Rules for rounding of numerical values (*second revision*)'. The number of significant places retained in the rounded off value should be the same as that of the specified value in this standard.

## Bureau of Indian Standards

BIS is a statutory institution established under the *Bureau of Indian Standards Act, 2016* to promote harmonious development of the activities of standardization, marking and quality certification of goods and attending to connected matters in the country.

### Copyright

BIS has the copyright of all its publications. No part of these publications may be reproduced in any form without the prior permission in writing of BIS. This does not preclude the free use, in the course of implementing the standard, of necessary details, such as symbols and sizes, type or grade designations. Enquiries relating to copyright be addressed to the Head (Publication & Sales), BIS.

### Review of Indian Standards

Amendments are issued to standards as the need arises on the basis of comments. Standards are also reviewed periodically; a standard along with amendments is reaffirmed when such review indicates that no changes are needed; if the review indicates that changes are needed, it is taken up for revision. Users of Indian Standards should ascertain that they are in possession of the latest amendments or edition by referring to the website-[www.bis.gov.in](http://www.bis.gov.in) or [www.standardsbis.in](http://www.standardsbis.in).

This Indian Standard has been developed from Doc No.: ETD 35 (24597).

### Amendments Issued Since Publication

Amend No.	Date of Issue	Text Affected

## BUREAU OF INDIAN STANDARDS

### Headquarters:

Manak Bhavan, 9 Bahadur Shah Zafar Marg, New Delhi 110002

Telephones: 2323 0131, 2323 3375, 2323 9402

Website: [www.bis.gov.in](http://www.bis.gov.in)

### Regional Offices:

Central : 601/A, Konnectus Tower -1, 6<sup>th</sup> Floor,  
DMRC Building, Bhavbhuti Marg, New  
Delhi 110002

Telephones

{ 2323 7617

Eastern : 8<sup>th</sup> Floor, Plot No 7/7 & 7/8, CP Block, Sector V,  
Salt Lake, Kolkata, West Bengal 700091

{ 2367 0012  
2320 9474

Northern : Plot No. 4-A, Sector 27-B, Madhya Marg,  
Chandigarh 160019

{ 265 9930

Southern : C.I.T. Campus, IV Cross Road, Taramani, Chennai 600113

{ 2254 1442  
2254 1216

Western : 5<sup>th</sup> Floor/MTNL CETTM, Technology Street, Hiranandani Gardens, Powai  
Mumbai 400076

{ 25700030  
25702715

**Branches :** AHMEDABAD, BENGALURU, BHOPAL, BHUBANESHWAR, CHANDIGARH, CHENNAI, COIMBATORE, DEHRADUN, DELHI, FARIDABAD, GHAZIABAD, GUWAHATI, HARYANA (CHANDIGARH), HUBLI, HYDERABAD, JAIPUR, JAMMU, JAMSHEDPUR, KOCHI, KOLKATA, LUCKNOW, MADURAI, MUMBAI, NAGPUR, NOIDA, PARWANOO, PATNA, PUNE, RAIPUR, RAJKOT, SURAT, VIJAYAWADA.