

विद्युत यांत्रिक प्राथमिक रिले
भाग 4 रीड रिले के लिए सामान्य एवं सुरक्षा
अपेक्षाएँ

**Electromechanical Elementary
Relays**
**Part 4 General and Safety Requirements
for Reed Relays**

ICS 29.120.70

© BIS 2024

© IEC 2020



भारतीय मानक ब्यूरो

BUREAU OF INDIAN STANDARDS

मानक भवन, 9 बहादुर शाह ज़फर मार्ग, नई दिल्ली - 110002

MANAK BHAVAN, 9 BAHADUR SHAH ZAFAR MARG
NEW DELHI - 110002

www.bis.gov.in www.standardsbis.in

NATIONAL FOREWORD

This Indian Standard (Part 4) which is identical to IEC 61810-4 : 2020 'Electromechanical elementary relays — Part 4: General and safety requirements for reed relays' issued by the International Electrotechnical Commission (IEC) was adopted by the Bureau of Indian Standards on the recommendation of the Power Systems Relays Sectional Committee and approval of the Electrotechnical Division Council.

This standard is published in several parts. The other parts in this series are:

- Part 1 General and safety requirements
- Part 2 Reliability
- Part 2/Sec 1 Procedure for the verification of b10 values
- Part 3 Relays with forcibly guided (mechanically linked) contacts
- Part 7 Test and measurement procedures

The text of the IEC standard has been approved as suitable for publication as an Indian Standard without deviations. Certain conventions are, however, not identical to those used in Indian Standards. Attention is particularly drawn to the following:

- a) Wherever the words 'International Standard' appears referring to this standard, they should be read as 'Indian Standard'; and
- b) Comma (,) has been used as a decimal marker, while in Indian Standards the current practice is to use a point (.) as the decimal marker.

In this standard, reference appears to International Standards for which Indian Standards also exists. The corresponding Indian Standards, which are to be substituted, are listed below along with their degree of equivalence for the editions indicated:

<i>International Standard</i>	<i>Corresponding Indian Standard</i>	<i>Degree of Equivalence</i>
IEC 60068-2-17 : 1994 Basic environmental testing procedures — Part 2-17: Tests — Test Q: Sealing	IS/IEC 60068-2-17 : 1994 Basic environmental testing procedures: Part 2 Tests, Section 17 Test Q: Sealing	Identical
IEC 61810-1 : 2015 Electromechanical elementary relays — Part 1: General and safety requirements IEC 61810-1 : 2015/AMD 1 : 2019	IS 17064 (Part 1) : 2018/ IEC 61810-1 : 2015 Electromechanical elementary relays: Part 1 General and safety requirements	Identical
IEC 61810-2 : 2017 Electromechanical elementary relays — Part 2: Reliability	IS 17064 (Part 2) : 2019/ IEC 61810-2 : 2017 Electromechanical elementary relays: Part 2 Reliability	Identical
IEC 61810-2-1 : 2017 Electromechanical elementary relays — Part 2-1: Reliability — Procedure for the verification of B ₁₀ values	IS 17064 (Part 2/Sec 1) : 2019/ IEC 61810-2-1 : 2017 Electromechanical elementary relays: Part 2 Reliability, Section 1 Procedure for the verification of B ₁₀ values	Identical
IEC 61810-7 : 2006 Electromechanical elementary relays — Part 7: Test and measurement procedures	IS/IEC 61810-7 : 2006 Electromechanical elementary relays — Part 7 Test and measurement procedures	Identical

(Continued on third cover)

CONTENTS

INTRODUCTION.....	v
1 Scope.....	1
2 Normative references	1
3 Terms and definitions	2
4 Influence quantities	4
5 Rated values	4
6 General provisions for testing.....	5
6.1 General.....	5
6.2 Type tests.....	5
6.3 Routine tests.....	6
6.4 Special tests	7
7 Documentation and marking	7
8 Heating.....	8
9 Basic operating function	8
10 Dielectric strength	9
11 Electrical endurance.....	10
12 Mechanical endurance.....	10
13 Clearances, creepage distances and solid insulation	10
13.1 General provisions.....	10
14 Terminations	10
15 Sealing	10
16 Heat and fire resistance.....	10
17 Short circuit capacity	11
18 Vibration.....	11
18.1 Procedure.....	11
18.2 Requirements	11
19 Shock.....	11
19.1 Procedure.....	11
19.2 Requirements	12
Annexes	13
Annex A (normative) Explanation regarding reed contacts of reed relays.....	14
Annex P (informative) High frequency characteristics test.....	15
P.1 General.....	15
P.2 Procedures	15
P.3 Requirements	16
Annex Q (informative) Special tests – Tests for environmental category	17
Q.1 General.....	17
Q.2 Classification of equipment	17
Q.3 Special tests for applications	17
Q.4 Railway applications – Rolling stock.....	17
Q.5 Tests and requirements	18
Bibliography.....	21

Figure 1 – Example of test arrangement for multi mounting.....	8
Figure A.1 – Example explaining terms relating to reed contacts of reed relay	14
Figure P.1 – Measurement circuit for scattering parameters measurement.....	16
Table 1 – Insulation resistance	4
Table 2 – Frequency range	5
Table 3 – Type testing	6
Table 4 – Routine tests	6
Table 5 – Special relays data.....	7
Table 6 – Dielectric voltage.....	9
Table 7 – Vibration test conditions	11
Table 8 – Shock test conditions	11
Table Q.1 – Special requirements for railway applications – rolling stock	18
Table Q.2 – Special tests for railway applications – rolling stock.....	18

INTRODUCTION

Reed relays have been used in wide fields such as household and similar appliances, security control systems for appliances, measuring instruments, medical equipment, semiconductor and chip test equipment, information and communication equipment, power distribution facilities and transit vehicles, etc.

IEC 61810-4 provides technical deviations/additions to IEC 61810-1 in order to specify general and safety requirements for reed relays, as a result of component safety standards for relevant systems.

The reed switches are used as the switching contacts of the reed relays, all the requirements for reed contacts (reed switches) within the reed relay are read in conjunction with IEC 62246 (all parts).

Indian Standard

ELECTROMECHANICAL ELEMENTARY RELAYS
PART 4 GENERAL AND SAFETY REQUIREMENTS FOR
REED RELAYS

1 Scope

This part of IEC 61810 applies to electromechanical elementary relays with reed switches (reed contacts) incorporated into general control circuits. It defines the basic functional and safety requirements in all areas of electrical engineering or electronics in accordance with the parts of IEC 61810 series and IEC 62246 series.

This document defines technical deviations/additions to IEC 61810-1. It specifies type tests, routine tests, special tests and environmental tests to confirm the service conditions for applications.

NOTE The terms reed switch(es) and reed contact(s) are both in use for the description of the contact set in reed relays.

2 Normative references

The following documents are referred to in the text in such a way that some or all of their content constitutes requirements of this document. For dated references, only the edition cited applies. For undated references, the latest edition of the referenced document (including any amendments) applies.

IEC 60068-2-17:1994, *Basic environmental testing procedures – Part 2-17: Tests – Test Q: Sealing*

IEC 60077-1:2017, *Railway applications – Electric equipment for rolling stock – Part 1: General service conditions and general rules*

IEC 60077-2:2017, *Railway applications – Electric equipment for rolling stock – Part 2: Electrotechnical components – General rules*

IEC 60571:2012, *Railway applications – Electric equipment used on rolling stock*

IEC 61373:2010, *Railway applications – Rolling stock equipment – Shock and vibration tests*

IEC 61810-1:2015, *Electromechanical elementary relays – Part 1: General and safety requirements*

IEC 61810-1:2015/AMD1:2019

IEC 61810-2:2017, *Electromechanical elementary relays – Part 2: Reliability*

IEC 61810-2-1:2017, *Electromechanical elementary relays – Part 2-1: Reliability – Procedure for the verification of B_{10} values*

IEC 61810-7:2006, *Electromechanical elementary relays – Part 7: Test and measurement procedures*

IEC 61810-10:2019, *Electromechanical elementary relays – Part 10: Additional functional aspects and safety requirements for high-capacity relays*

IEC 62246-1:2015, *Reed switches – Part 1: Generic specification*

IEC 62246-1-1:2018, *Reed switches – Part 1-1: Generic specification – Blank detail specification*

IEC 62497-1:2010, *Railway applications – Insulation coordination – Part 1: Basic requirements – Clearances and creepage distances for all electrical and electronic equipment*
IEC 62497-1:2010/AMD1:2013

IEC 62498-1:2010, *Railway applications – Environmental conditions for equipment – Part 1: Equipment on board rolling stock*

3 Terms and definitions

For the purposes of this document, the terms and definitions given in IEC 61810-1 and the following apply.

ISO and IEC maintain terminological databases for use in standardization at the following addresses:

- IEC Electropedia: available at <http://www.electropedia.org/>
- ISO Online browsing platform: available at <http://www.iso.org/obp>

3.2 Terms and definitions of relay types

3.2 of IEC 61810-1:2015 is applicable with the following addition:

3.2.7

reed relay

electromechanical control circuit devices with connecting terminals, consisting of reed switch sets (reed contact sets) and coil fitting with/without a housing which could be plastic or metal

Note 1 to entry: See Figure A.1.

3.4 Terms and definitions of operating values

3.4 of IEC 61810-1:2015 is applicable with the following addition:

3.4.7

magnetic interference

tendency of a relay to be influenced by the magnetic field from an adjacent energized relay or any other surrounding solenoid

Note 1 to entry: This influence can result in depression or elevation of the operate and release voltage of the affected relay, possibly causing them to fall outside their specification.

Note 2 to entry: Magnetic interference can be minimized by alternating the polarity of adjacent relay coils, by magnetic shielding, or by placing two relays at right angles to each other.

3.8 Terms and definitions related to high frequency characteristics

3.8.1

frequency range

<of an equipment> set of frequencies over which an equipment can be adjusted to operate satisfactorily

Note 1 to entry: The frequency range of a relay can be subdivided into switched subranges which may or may not be contiguous.

[SOURCE: IEC 60050-702:1992, 702-09-68, modified – “an equipment“ has been replaced with “a relay” in the “Note 1 to entry”]

3.8.2

capacitance

<between open contacts> ability to store an electric charge between contacts

3.8.3

capacitance

<between coil and contacts> ability to store an electric charge between contact and coil

Note 1 to entry: It can have adverse effects for use in high frequency signal transmission circuits of information and communication equipment.

3.8.4

impedance

<of a relay> quotient of a voltage by a current for a passive linear two-terminal element or two-terminal circuit with terminals A and B under sinusoidal conditions

[SOURCE: IEC 60050-131:2013, 131-12-43, modified – The definition has been replaced]

3.8.5

isolation

<of a relay> ratio of the power delivered to the output port of a relay, with open contacts, at a specific frequency, compared to the power emitted from the corresponding output port

3.8.6

insertion loss

resulting from the insertion of a network into a transmission system, the ratio of the power delivered to that part of the system following the network, before insertion of the network, to the power delivered to that same part after insertion of the network

Note 1 to entry: The insertion loss is generally expressed in decibels.

[SOURCE: IEC 60050-726:1982, 726-06-07]

3.8.7

return loss

modulus of the reciprocal of the reflection factor, generally expressed in decibels

Note 1 to entry: When impedances can be defined, the return loss is given by the formula:

$$-20\lg|r| = 20\lg\left|\frac{Z-Z'}{Z+Z'}\right|$$

where Z is the characteristic impedance of a transmission line ahead of a discontinuity, or the impedance of a source, and Z' is the impedance after the discontinuity or the load impedance seen from the junction between the source and the load.

[SOURCE: IEC 60050-702:1992, 702-07-25]

3.8.8

repeatability

<of results of measurements> closeness of agreement between the results of successive measurements of the same measurand, carried out under the same conditions of measurement, i.e.:

- by the same measurement procedure;

- by the same observer;
- with the same measuring instruments, used under the same conditions;
- in the same laboratory;
- at relatively short intervals of time.

[SOURCE: IEC 60050-311:2001, 311-06-06, modified – The Note has been omitted.]

4 Influence quantities

Clause 4 of IEC 61810-1:2015 is applicable.

5 Rated values

Clause 5 of IEC 61810-1:2015 is applicable with the following deviations/additions.

5.2 Rated coil voltage/rated coil voltage range

b) DC voltage, recommended values:

15 V; 32 V; 36 V; 50 V; 55 V; 64 V; 72 V; 87 V; 96 V.

5.8 Contact loads

a) Resistive loads, recommended values

Current: 0,1 A; 0,2 A; 0,3 A; 0,5 A; 1 A; 2 A; 3 A; 5 A; 6 A; 8 A; 10 A; 12 A; 16 A; 20 A; 25 A; 30 A and submultiples thereof.

Voltage: 1 V; 3 V; 4,5 V; 5 V; 12 V; 24 V; 36 V; 42 V; 48 V; 110 V; 125 V; 230 V; 250 V; 300 V; 400 V; 480 V; 500 V; 690 V; 1 000 V (AC/DC); 1 500 V DC, 2 000 V DC, 3 000 V DC, 5 000 V DC, 7 000 V DC, 8 000 V DC, 10 000 V DC, 12 000 V DC and submultiples thereof.

b) Recommended inductive loads: see Annex F of IEC 62246-1:2015.

NOTE 1 IEC 61810-4 considers values higher than 1 500 V DC which is the scope of IEC 61810-1.

NOTE 2 Special requirement on withstand voltage for blocking inductive surge can be applied.

NOTE 3 The voltage values are based on 4.4 of IEC 62246-1:2015.

5.12 Withstand voltage

Recommended withstand voltages: 30 V; 60 V; 125 V; 200 V; 330 V; 500 V; 800 V; 1 500 V; 2 500 V; 4 000 V; 7 000 V; 10 000 V; 15 000 V; 18 000 V.

NOTE The voltage values are based on 4.4 of IEC 62246-1:2015.

5.13 Insulation resistance

Recommended insulation resistance values are listed in Table 1.

Table 1 – Insulation resistance

Insulation resistance (Ω)							
$>10^8$	$> 10^9$	$> 10^{10}$	$> 10^{11}$	$> 10^{12}$	$> 10^{13}$	$> 10^{14}$	$> 10^{15}$

NOTE Test and measurement procedures for insulation resistance are accordance with 4.11 of IEC 61810-7:2006.

5.14 Frequency range

Recommended contact load frequency range can be specified according to Table 2.

Table 2 – Frequency range

Frequency range (Hz)								
3×10^5 to 3×10^6	3×10^6 to 30×10^6	30×10^6 to 300×10^6	DC to 1×10^8	DC to 2×10^9	DC to 4×10^9	DC to 7×10^9	DC to $1,5 \times 10^{10}$	DC to 2×10^{10}

6 General provisions for testing

Clause 6 of IEC 61810-1:2015 is applicable with the following additions:

6.1 General

Tests shall be made to prove compliance with the requirements laid down in this document.

Tests are as follows:

- type tests which shall be made on representative samples of each particular reed relays;
- routine tests which shall be made on each individual piece of reed relays manufactured to this document;
- special tests which shall be made following a technical specification, according to agreement between manufacturer and user;

6.2 Type tests

The specimens shall be grouped in 11 inspection lots, and the related tests shall be taken from Table 3 of this document.

Table 3 of this document replaces Table 3 of IEC 61810-1:2015.

Table 3 – Type testing

Inspection lot	Tests	Clause	Additional references
1	Documentation and marking	7	IEC 60417
	Heating (typical coil voltage)	8	IEC 60085
	Basic operating function (all coil voltages)	9	
2	Dielectric strength	10	
3	Electrical endurance (per contact load and contact material)	11	
4	Mechanical endurance	12	
5	Clearances, creepage distances and distances through solid insulation	13	IEC 60664-1
6	Terminations	14	
	Sealing (if applicable)	15	IEC 60068-2-17
7	Heat and fire resistance	16	IEC 60695-2-10
8	Short-circuit capacity (if applicable)	17	
9	Vibration test (if applicable)	18	IEC 60068-2-6
10	Shock test (if applicable)	19	IEC 60068-2-27
11	High frequency characteristics (if applicable)	Annex P	

In the relevant clauses, the requirements to be checked as well as the related tests are specified. The routine tests shall be taken from Table 4.

6.3 Routine tests

Table 4 of this document replaces Table 4 of IEC 61810-1:2015/AMD1:2019.

Table 4 – Routine tests

Inspection lot	Test	Clause	Additional references
all ^e	Marking and documentation	7	Table 6 of IEC 61810-1:2015, 1a; 1b; 1c
all ^e	Basic operating functions	9 ^a	Mode II applies ^b
all ^e	Sealing (option)	15 ^c	IEC 60068-2-17 or IEC 62246-1-1
all ^e	Dielectric strength	10.2 ^d	—

^a The preconditioning within Table 11 of IEC 61810-1:2015 for operate as well as release does not apply. For routine testing 9.2.2 of IEC 61810-1:2015 could be handled via 9.2.1 of IEC 61810-1:2015. As these tests is usually carried out at room temperature, the manufacturer has to specify an appropriate level for the operate or release voltage to ensure that the relay will work at the maximum (operate) and minimum (release) permissible ambient temperature within the defined values.

^b 9.3 of IEC 61810-1:2015 for bistable relays applies accordingly.

^c The manufacturer specifies the detail conditions.

^d Dielectric test for routine test could be carried out for duration of 1 s in accordance with IEC 61810-7:2006, 4.9. The test voltage shall not have any negative impact on the insulation (further use). Other parameters like current limit or specification of the high-voltage transformer shall be specified by the manufacturer at an appropriate value. 10.3 of IEC 61810-1:2015 may apply as alternate to 10.2 of IEC 61810-1:2015 especially for existing designs.

^e For routine tests by definition, all products are tested.

6.4 Special tests

6.4.1 General requirements

The conducting of special tests is at the discretion of the manufacturer.

The samples shall pass the type tests and routine tests which Table 3 and Table 4 specify accordingly.

6.4.2 Environmental tests

In cases where it is necessary to verify the behaviour of products under special environmental conditions (e.g. damp heat, salt mist, vibration and shock), the tests shall be conducted according to Annex Q.

7 Documentation and marking

Clause 7 of IEC 61810-1:2015 is applicable with the following deviations/additions.

Table 5 of this document adds to Table 6 of IEC 61810-1:2015.

Table 5 – Special relays data

N°	Data	Notes	Place of indication
2 Coil data			
2d	Category or class (Optional) Voltage changes Overvoltage	Values of the limits (see Q.5.1)	Relay or catalogue or instruction sheet
3 Contact data			
3h	Capacitance (Optional) (Between open contacts and between coil and contacts)	Value of the limits	Catalogue or instruction sheet
4 Insulation data			
4f	Withstand voltage (Optional) (Between open contacts and between coil and contacts)	Values of the limits or class (see 5.12)	Catalogue or instruction sheet
4g	Insulation resistance (Optional) (Between open contacts and between coil and contacts)	Values of the limits or class (see 5.13)	Catalogue or instruction sheet
5 General data			
5l	Vibration	Category or class (Optional, see Q.5.3)	Relay or catalogue or instruction sheet
5m	Shock	Category or class (Optional, see Q.5.3)	Relay or catalogue or instruction sheet
6 High frequency characteristics (Optional)			
6a	Frequency range	Values of the limits or class (see 5.13)	Catalogue or instruction sheet
6b	Isolation	Values of the limits	Catalogue or instruction sheet
6c	Insertion loss	Values of the limits	Catalogue or instruction sheet
6d	Return loss	Values of the limits	Catalogue or instruction sheet

NOTE 1 For special data, if typical applications (high frequency characteristic, etc.) are applicable, these relays data in Table 5 are added.

NOTE 2 For special data, if railway applications are applicable, these relays data for category or class (battery voltage, vibration and shock, etc.) in Table 5 are added.

8 Heating

Clause 8 of IEC 61810-1:2015 is applicable.

9 Basic operating function

Clause 9 of IEC 61810-1:2015 is applicable with the following additions:

9.4 Magnetic interference

The manufacturer shall declare different values for functional operate voltage and release voltage between single mounting and multi mounting (i.e. reed relays are mounted in array arrangement).

For multi mounting, the test is carried out in accordance with Method 2 of 4.37 of IEC 61810-7:2006 to check the values of functional performance of the relay subjected to the effects of external magnetic induction from other relays. The mounting grid pattern shall be specified by the manufacturer. See Figure 1 for example, all relevant details of the test arrangement (e.g., S_1 : horizontal mounting distance and S_2 : vertical mounting distance and coil polarity) are to be indicated in the test report.

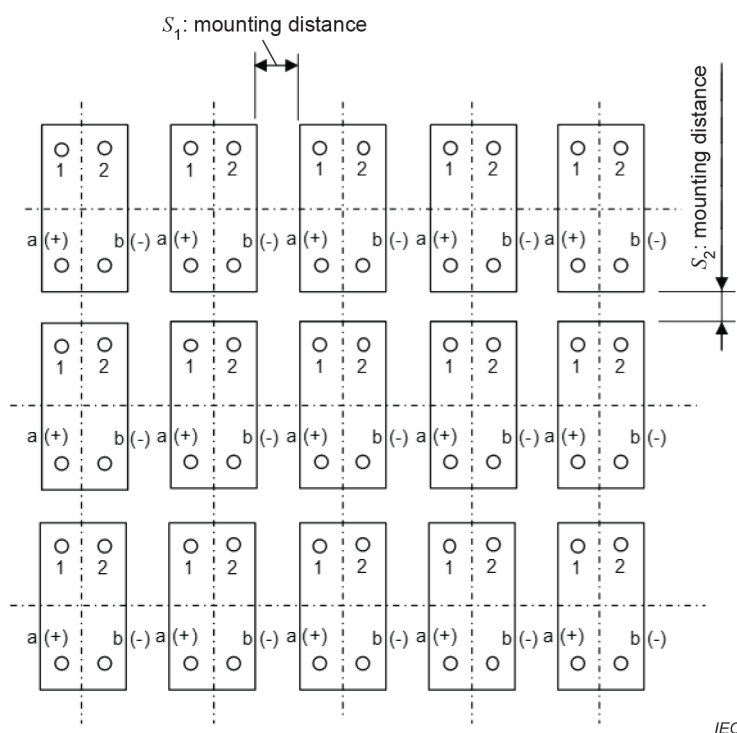

Where, 1, 2: contact terminals, a, b: coil terminals

S_1 : horizontal mounting distance between relays, S_2 : vertical mounting distance between relays

Figure 1 – Example of test arrangement for multi mounting

The manufacturer shall define in case for applications with additional influence from surrounding solenoid (like from filter or switching power supplies inductances) which additional magnetic influence testing shall be performed.

To cover this, the method 1 and/or 3 of 4.37 of IEC 61810-7:2006 is recommended.

9.5 Time parameters, contact resistance

The manufacturer shall test operating time, release time, bounce time and contact resistance at the routine tests, see Table 4.

NOTE Flywheel diode (omit if not applicable) are connected in parallel with the coils when measuring time parameters unless otherwise specified in the detail specification.

10 Dielectric strength

Clause 10 of IEC 61810-1:2015 is applicable with the following deviations/additions.

Addition to IEC 61810-1:2015:

Requirements for reed contacts (reed switches) within the reed relay are in conjunction with IEC 62246 (all parts).

10.2.1 Requirements

The leakage current through insulation between open contacts, between adjacent contacts and between coil and contacts, in Table 6, shall not exceed 3 mA for a specified duration (at least 60 s).

Table 6 – Dielectric voltage

Test place	Rated voltage U_n V	Test voltage ^a V
Between adjacent contacts, and between coil and contacts	$U_n < 30$	250
	$30 \leq U_n < 60$	500
	$60 \leq U_n < 125$	1 300
	$125 \leq U_n < 250$	1 500
	$250 \leq U_n < 330$	1 600
	$330 \leq U_n < 500$	1 700
	$500 \leq U_n < 800$	2 000
	$800 \leq U_n < 1 500$	2 700
	$1 500 \leq U_n < 2 500$	3 700
	$2 500 \leq U_n < 4 000$	5 200
	$4 000 \leq U_n < 7 000$	8 200
	$7 000 \leq U_n < 10 000$	11 200
$10 000 \leq U_n < 15 000$	16 200	
$15 000 \leq U_n < 18 000$	19 200	
Between open contacts	Test voltages are given in 6.8.1 of IEC 62246-1:2015.	
^a The values are derived from the formula $U_n + 1 200$ V (rounded).		

11 Electrical endurance

Clause 11 of IEC 61810-1:2015 is applicable with the following deviations/additions.

Overload and endurance test shall be selected by the manufacturer in accordance with 6.22 of IEC 62246-1:2015; however, the requirements related to the test coil defined in Annex A of IEC 62246-1:2015 and the ambient test environment are not applicable.

11.3 Failure and malfunction criteria

The last sentence of this subclause of IEC 61810-1:2015 is deleted and replaced by:

The category and criteria of temporary malfunction are specified according to 6.22.8 and 6.22.9 c) of IEC 62246-1:2015.

11.4 Final dielectric test

The fourth sentence of this subclause of IEC 61810-1:2015 is deleted.

12 Mechanical endurance

Clause 12 of IEC 61810-1:2015 is applicable.

13 Clearances, creepage distances and solid insulation

Clause 13 of IEC 61810-1:2015 is applicable with the following deviations/additions.

13.1 General provisions

Addition to IEC 61810-1:2015:

This document does not deal with distances between the reed contacts (reed switch) within the reed relay as insulation is guaranteed with withstand voltage as defined in 10.2.

14 Terminations

Clause 14 of IEC 61810-1:2015 is applicable.

15 Sealing

Clause 15 of IEC 61810-1:2015 is applicable with the following deviations/additions.

The sealing test is performed only with reed contacts (reed switches) within the reed relay.

The test shall be performed in conjunction with IEC 60068-2-17:1994 or IEC 62246-1-1:2018, 5.2.

16 Heat and fire resistance

Clause 16 of IEC 61810-1:2015 is applicable.

17 Short circuit capacity

IEC 61810-10:2019, Annex R is applicable.

18 Vibration

18.1 Procedure

Subclause 4.28, Procedure 1 of IEC 61810-7:2006 is applicable with the following additions.

This test is added in accordance with Table 7.

Table 7 – Vibration test conditions

Range of frequency (Hz)	10 to 55
Vibration double amplitude (mm)	1,5
Sweep rate	10 to 55 to 10 Hz, 1 sweep/min.
Directions and hours	Three mutually perpendicular axes, 2 hours each without coil voltage
How to change frequency	Logarithmic or linear approximation
Total test time (h)	6
NOTE No switching load between contacts.	

18.2 Requirements

During the test, no visible damage (e.g., glass broken of reed contacts) shall be observed. Immediately after the test, the reed relay shall meet the requirements of the following tests:

- visual inspection (4.6 of IEC 61810-7:2006);
- basic operating function (9.2.1 of IEC 61810-1:2015);
- sealing (Clause 15 of this document).

19 Shock

19.1 Procedure

Subclause 4.26, Method 1 of IEC 61810-7:2006 is applicable with the following deviations/additions.

This test is added in accordance with Table 8.

18 shocks in total shall be applied 3 times in each direction of three mutually perpendicular axes without coil voltage.

Table 8 – Shock test conditions

Peak acceleration m/s ²	Duration of pulse ms	Velocity change m/s
500	11	3,43
NOTE No switching load between contacts.		

19.2 Requirements

During the test, no visible damage (e.g., glass broken or reed contacts) shall be observed. Immediately after the test, the reed relay shall meet the requirements of the following tests:

- visual inspection (4.6 of IEC 61810-7:2006);
- basic operating function (9.2.1 of IEC 61810-1:2015);
- sealing (Clause 15 of this document).

Annexes

Addition to IEC 61810-1:2015:

All annexes of IEC 61810-1:2015 are applicable with the following deviations/additions.

Annex A (normative)

Explanation regarding reed contacts of reed relays

Replacement of Annex A of IEC 61810-1:2015:

For basic operating function, Figure A.1 of this document replaces Figure A.2 of IEC 61810-1:2015.

All requirements for reed contacts (reed switches) within the reed relay are in conjunction with IEC 62246 (all parts).

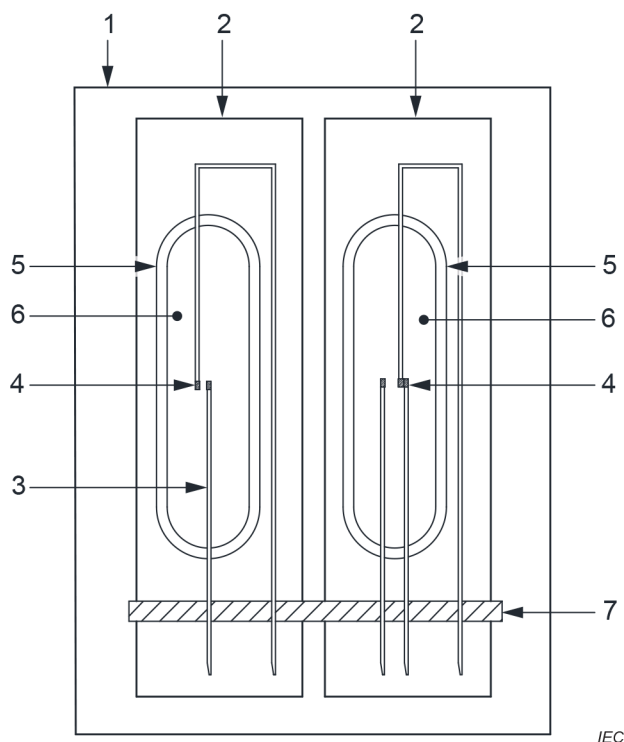

Key

- 1 Reed contact set
- 2 Reed contact (reed switch)
- 3 Contact blade
- 4 Contact point
- 5 Sealed glass
- 6 Inner gas or vacuum
- 7 Fixing

Figure A.1 – Example explaining terms relating to reed contacts of reed relay

Annex P (informative)

High frequency characteristics test

Addition to IEC 61810-1:2015:

P.1 General

High repeatability and durability of the RF characteristics to switch signals from DC to 3 GHz and above are required. This can be useful for switching signals between oscilloscopes, spectrum analysers, network analysers, and other RF test equipment.

In order to verify the requirements regarding high frequency characteristics for use in high frequency signal transmission circuits, the following tests shall be carried out by the manufacturer.

The high frequency characteristics of the reed relay are specified with the measurement results of an insertion loss, a return loss and isolation by using scattering parameters.

P.2 Procedures

The scattering parameters for isolation, insertion loss and return loss shall be measured by the test circuit given in Annex P, unless otherwise specified in the detail specification.

The following procedures shall be followed to measure high frequency characteristics:

- a) The coaxial communication cable should be used at connection length, less than 1 m with the wide frequency range (see Figure P.).
- b) The radio-frequency connector should be used with the wide frequency range and/or the low insertion loss.
- c) Substrate for measurement: In order to reduce the insertion loss, the design of the substrate is most important. Therefore, the manufacturer shall specify the measurement conditions for the substrate material of the testing PCB.
- d) The test for insulation should be measured up to 3 times of high frequency which manufacturer recommends when reed relay is OFF status.
- e) The tests for insertion loss and return loss should be measured up to 3 times of high frequency which is recommended by the manufacturer when the reed relay displays an ON status.
- f) The detailed repeatability evaluation procedure (e.g. repeatability is less than $\pm 0,1$ dB after 300 000 operations with no switching load) shall be used with agreement between the user and the manufacturer.

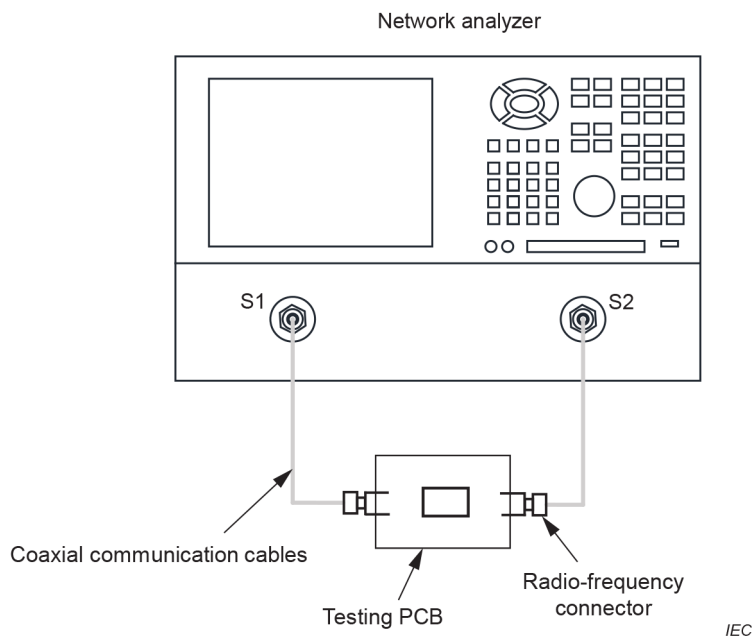

Figure P.1 – Measurement circuit for scattering parameters measurement

P.3 Requirements

For the measurement, the frequency band of the reed relay should be defined as a frequency lower than the maximum frequency value at which the insertion loss is -3 dB in power ratio. In that case, the conditions for return loss and insertion loss should be specified by the manufacturer.

The scattering parameters should be measured in both forward and reverse directions.

Unless otherwise prescribed in the detail specification, there shall be a correctly matched impedance for a reed relay to function as an efficient component in a 50Ω transmission line.

Annex Q (informative)

Special tests – Tests for environmental category

Addition to IEC 61810-1:2015:

Q.1 General

The purpose of this annex is to define the requirements allowing to assess the ability of a reed relay to perform its function where intended to be used under certain climatic conditions different from the type tests as defined in Table 3.

This annex states the service conditions and sequences and the results to be obtained.

The following special tests shall be made either at the discretion of the manufacturer or according to an agreement between the manufacturer and the user. As special tests, these additional tests are not mandatory, and it is necessary for a reed relay to satisfy any of these tests to conform to this document.

Q.2 Classification of equipment

The equipment classification is defined according to the relevant application documents.

These documents specify the different parameter classes (voltage changes of power supply, ambient temperature, vibration, shock, environments, etc.).

Q.3 Special tests for applications

It is necessary to choose the appropriate level of severity of the special tests for applications and to harmonize between the relevant standards.

Q.4 Railway applications – Rolling stock

The railway market requests reliability data including the expected useful life and the maintenance procedures. When using reed relays to equipment on rolling stock, the system designer measures and verifies the safety requirements in accordance with the typical following railway publications by IEC TC 9:

Table Q.1 and Table Q.2 describe special tests that shall be used for rolling stock.

The number of samples is specified by the manufacturers.

Table Q.1 – Special requirements for railway applications – rolling stock

Item no.	Requirements	Reference standards
Q.5.1.1	Basic operating function (all coil voltages)	IEC 60571:2012 IEC 60077-1:2017
Q.5.1.2	Operating ambient temperature (all coil voltages)	IEC 60077-1:2017, Table 1 IEC 60571:2012, 5.1.2
Q.5.1.3	Coil fluctuation range (all coil voltages)	IEC 60571:2012, 4.1.2
Q.5.1.4	Interruptions of voltage supply (all coil voltages)	IEC 60571:2012, 5.1.1.3
Q.5.1.5	Overvoltage category: OV1 to OV4 (all coil voltages)	IEC 62497-1:2013, 8.2
Q.5.2	Fire safety performance (if applicable)	Standards or national practices required in the destination of products

Table Q.2 – Special tests for railway applications – rolling stock

Test no.	Tests and requirements	Reference standards of test conditions
Q.5.3	Functional random vibration test	IEC 61373:2010, Table 1 and Table 2
	Simulated long-life testing at increased random vibration levels	
	Shock test	IEC 61373:2010, Table 3
Q.5.4	Environmental tests	IEC 60077-2:2017, Table 9 IEC 60571:2012, Table 2 IEC 62498-1
Q.5.5	Reliability tests	IEC 61810-2:2017 IEC 61810-2-1:2017 IEC 62246-1:2015, 6.28

Q.5 Tests and requirements

Q.5.1 Basic operating function

Q.5.1.1 General

Clause 9 of this document is applicable for the function check under test of a reed relay.

Q.5.1.2 Operating ambient temperature

The operating ambient temperature is designed according to IEC 60571:2012, 4.1.2 and/or IEC 60077-1:2017 depending on class, which is assigned by the location of the device.

The manufacturer declares the applicable classes or the temperature ranges.

Regarding temperatures other than those prescribed, there should be an agreement with the user.

Q.5.1.3 Coil fluctuation range

The coil fluctuation range is designed according to IEC 60077-1:2017, Table 1 and IEC 60571:2012, 4.1.2.

The manufacturer declares the applicable classifications or voltage changes.

Regarding coil fluctuation range other than prescribed, agreement with the user is taken.

Q.5.1.4 Interruptions of voltage supply

The interruptions of voltage supply are designed according to IEC 60571:2012, 5.1.1.3.

The manufacturer declares the applicable classes.

Regarding time values other than those prescribed, there should be an agreement with the user.

Q.5.1.5 Overvoltage category: OV1 to OV4

The manufacturer shall declare the applicable overvoltage categories according to 8.2 of IEC 62497-1:2013.

Q.5.2 Fire safety performance (if applicable)

The requirements of fire safety performance are different in countries and regions. Then national practices for fire safety required in the destination of the products should be confirmed and verified.

Q.5.3 Shock and vibration tests

Shock and vibration tests for railway applications are completely different from IEC 60068 (all parts).

- 1) Functional random vibration tests for severities are carried out according to IEC 61373:2010, Table 1 and simulated long-life tests at increased random vibration levels are carried out according to IEC 61373:2010, Table 2 depending on class, which is assigned by the location of the device.

Clause 18 of this document is applicable for the function check under test of the reed relay. The mounting method under test of the reed relay is agreed with the user.

The applicable categories and classes are declared by the manufacturer.

- 2) Shock tests are carried out according to IEC 61373:2010, Table 3 depending on class, which is assigned by the location of the device.

Clause 19 of this document is applicable for the function check under test of the reed relay. The mounting method of the reed relay under test is agreed with the user.

The applicable categories and classes are declared by the manufacturer.

Q.5.4 Environmental tests

The reed relay can be exposed throughout its life to various environmental conditions (e.g. cold, dry heat, damp heat, salt mist, etc.) as defined in IEC 60077-2:2017, Table 9 and/or IEC 60571:2012, Table 2.

The environmental tests are carried out in accordance with methods to be agreed between the user and the manufacturer.

After tests, reed relays are capable of performing the functional operation tests (see 6.3).

Q.5.5 Reliability tests

The reliability tests are carried out in accordance with IEC 61810-2 and IEC 61810-2-1 for B_{10} values and IEC 62246-1:2015, 6.28 for random failure. The reliability level on switching load should be agreed between the user and the manufacturer.

The required performances (e.g., reliability target, maintenance cycle and/or safety target) for the specific application are based on IEC 62278 and/or IEC 62425.

NOTE Please note that when reliability values for components are used, that also other factors like diagnostic coverage of the component in the system are taken into account.

Bibliography

This clause of IEC 61810-1:2015 is applicable with the following deviations/additions.

IEC 60050-131:2002, *International Electrotechnical Vocabulary (IEV) – Part 131: Circuit theory*
IEC 60050-131:2002/AMD1:2008
IEC 60050-131:2002/AMD2:2013
IEC 60050-131:2002/AMD3:2019

IEC 60050-300:2001, *International Electrotechnical Vocabulary (IEV) – Part 300: Electrical and electronic measurements and measuring instruments – Part 311: General terms relating to measurements – Part 312: General terms relating to electrical measurements – Part 313: Types of electrical measuring instruments – Part 314: Specific terms according to the type of instrument*

IEC 60050-726:1982, *International Electrotechnical Vocabulary (IEV) – Part 726: Transmission lines and waveguides*

IEC 60068 (all parts), *Environmental testing*

IEC 60068-2-6, *Environmental testing – Part 2-6: Tests – Test Fc: Vibration (sinusoidal)*

IEC 60068-2-27, *Environmental testing – Part 2-27: Tests – Test Ea and guidance: Shock*

IEC 60529:1989, *Degrees of protection provided by enclosures (IP Code)*
IEC 60529:1989/AMD1:1999
IEC 60529:1989/AMD2:2013

IEC 60721-3-3:2019, *Classification of environmental conditions – Part 3-3: Classification of groups of environmental parameters and their severities – Stationary use at weatherprotected locations*

IEC 60870-2-2:1996, *Telecontrol equipment and systems – Part 2: Operating conditions – Section 2: Environmental conditions (climatic, mechanical and other non electrical influences)*

IEC 60947-1:2020, *Low-voltage switchgear and controlgear – Part 1: General rules*

IEC 61643-21:2000, *Low voltage surge protective devices – Part 21: Surge protective devices connected to telecommunications and signalling networks – Performance requirements and testing methods*
IEC 61643-21:2000/AMD1:2008
IEC 61643-21:2000/AMD2:2012

IEC 61810 (all parts), *Electromechanical elementary relays*

IEC TR 62246 (all parts), *Reed switches*

IEC TR 62246-3:2018, *Reed switches – Part 3: Reliability data for reed switch-devices in typical safety applications*

IEC 62278, *Railway applications – Specification and demonstration of reliability, availability, maintainability and safety (RAMS)*

IEC 62425, *Railway applications – Communication, signalling and processing systems – Safety related electronic systems for signalling*

IEC 62498-3:2010, *Railway applications – Environmental conditions for equipment – Part 3: Equipment for signalling and telecommunications*

IEC Guide 104:2019, *The preparation of safety publications and the use of basic safety publications and group safety publications*

ISO IEC Guide 51:2014, *Safety aspects – Guidelines for their inclusion in standards*

ISO 4589-2:2017, *Plastics – Determination of burning behaviour by oxygen index – Part 2: Ambient-temperature test*

ISO 5659-2:2017, *Plastics – Smoke generation – Part 2: Determination of optical density by a single-chamber test*

<i>International Standard</i>	<i>Corresponding Indian Standard</i>	<i>Degree of Equivalence</i>
IEC 61810-10 : 2019 Electromechanical elementary relays — Part 10: Additional functional aspects and safety requirements for high-capacity relays	IS 17064 (Part 10) : 2024/ IEC 61810-10 : 2019 Electromechanical elementary relays: Part 10 Additional functional aspects and safety requirements for high-capacity relays	Identical
IEC 62246-1 : 2015 Reed switches — Part 1: Generic specification	IS 17066 (Part 1) : 2018/ IEC 62246-1 : 2015 Reed switches: Part 1 Generic specification	Identical
IEC 62246-1-1 : 2018 Reed switches — Part 1-1: Generic specification — Blank detail specification	IS/IEC 62246-1-1 : 2018 Reed switches: Part 1 Generic specification, Section 1 Blank detail specification (<i>first revision</i>)	Identical

The Committee has reviewed the provisions of the following international standards referred in this standard and decided that they are acceptable for use in conjunction with this standard.

<i>International Standard</i>	<i>Title</i>
IEC 60077-1 : 2017	Railway applications — Electric equipment for rolling stock — Part 1: General service conditions and general rules
IEC 60077-2 : 2017	Railway applications — Electric equipment for rolling stock — Part 2: Electrotechnical components — General rules
IEC 60571 : 2012	Railway applications — Electric equipment used on rolling stock
IEC 61373 : 2010	Railway applications — Rolling stock equipment — Shock and vibration tests
IEC 62497-1 : 2010 IEC 62497-1 : 2010/ AMD 1 : 2013	Railway applications — Insulation coordination — Part 1: Basic requirements — Clearances and creepage distances for all electrical and electronic equipment
IEC 62498-1 : 2010	Railway applications — Environmental conditions for equipment — Part 1: Equipment on board rolling stock

Only the English language text has been retained while adopting it in this Indian Standard, and as such, the page numbers given here are not the same as in the IEC publication.

For the purpose of deciding whether a particular requirement of this standard is complied with the final value, observed or calculated expressing the result of a test or analysis shall be rounded off in accordance with IS 2 : 2022 'Rules for rounding of numerical values (*second revision*)'. The number of significant places retained in the rounded off value should be the same as that of the specified value in this standard.

Bureau of Indian Standards

BIS is a statutory institution established under the *Bureau of Indian Standards Act, 2016* to promote harmonious development of the activities of standardization, marking and quality certification of goods and attending to connected matters in the country.

Copyright

BIS has the copyright of all its publications. No part of these publications may be reproduced in any form without the prior permission in writing of BIS. This does not preclude the free use, in the course of implementing the standard, of necessary details, such as symbols and sizes, type or grade designations. Enquiries relating to copyright be addressed to the Head (Publication & Sales), BIS.

Review of Indian Standards

Amendments are issued to standards as the need arises on the basis of comments. Standards are also reviewed periodically; a standard along with amendments is reaffirmed when such review indicates that no changes are needed; if the review indicates that changes are needed, it is taken up for revision. Users of Indian Standards should ascertain that they are in possession of the latest amendments or edition by referring to the website-www.bis.gov.in or www.standardsbis.in.

This Indian Standard has been developed from Doc No.: ETD 35 (24590).

Amendments Issued Since Publication

Amend No.	Date of Issue	Text Affected

BUREAU OF INDIAN STANDARDS

Headquarters:

Manak Bhavan, 9 Bahadur Shah Zafar Marg, New Delhi 110002

Telephones: 2323 0131, 2323 3375, 2323 9402

Website: www.bis.gov.in

Regional Offices:

	Telephones
Central : 601/A, Konnectus Tower -1, 6 th Floor, DMRC Building, Bhavbhuti Marg, New Delhi 110002	{ 2323 7617
Eastern : 8 th Floor, Plot No 7/7 & 7/8, CP Block, Sector V, Salt Lake, Kolkata, West Bengal 700091	{ 2367 0012 2320 9474
Northern : Plot No. 4-A, Sector 27-B, Madhya Marg, Chandigarh 160019	{ 265 9930
Southern : C.I.T. Campus, IV Cross Road, Taramani, Chennai 600113	{ 2254 1442 2254 1216
Western : 5 th Floor/MTNL CETTM, Technology Street, Hiranandani Gardens, Powai Mumbai 400076	{ 25700030 25702715

Branches : AHMEDABAD, BENGALURU, BHOPAL, BHUBANESHWAR, CHANDIGARH, CHENNAI, COIMBATORE, DEHRADUN, DELHI, FARIDABAD, GHAZIABAD, GUWAHATI, HARYANA (CHANDIGARH), HUBLI, HYDERABAD, JAIPUR, JAMMU, JAMSHEDPUR, KOCHI, KOLKATA, LUCKNOW, MADURAI, MUMBAI, NAGPUR, NOIDA, PARWANOO, PATNA, PUNE, RAIPUR, RAJKOT, SURAT, VIJAYAWADA.