

विसफोटी पर्यावरण

भाग 47 2-तार वाले आंतरिक रूप से सुरक्षित
ईथरनेट अवधारणा द्वारा उपकरण सुरक्षा

Explosive Atmospheres

Part 47 Equipment Protection by
2-Wire Intrinsically Safe Ethernet
Concept (2-WISE)

ICS 29.260.20

© BIS 2024

© IEC 2021



भारतीय मानक ब्यूरो

BUREAU OF INDIAN STANDARDS

मानक भवन, 9 बहादुर शाह ज़फर मार्ग, नई दिल्ली - 110002

MANAK BHAVAN, 9 BAHADUR SHAH ZAFAR MARG
NEW DELHI - 110002

www.bis.gov.in www.standardsbis.in

NATIONAL FOREWORD

This Indian Standard which is identical to IEC TS 60079-47 'Explosive atmospheres — Part 47: Equipment protection by 2-wire intrinsically safe ethernet concept (2-wise)' issued by the International Electrotechnical Commission (IEC) was adopted by the Bureau of Indian Standards on the recommendation of the Electrical Apparatus For Explosive Atmosphere Sectional Committee had been approved by the Electrotechnical Division Council.

The text of IEC standard has been approved as suitable for publication as an Indian Standard without deviations. Certain terminologies and conventions are, however, not identical to those used in Indian Standards. Attention is particularly drawn to the following:

- a) Wherever the words 'International Standard' appear referring to this standard, they should be read as 'Indian Standard'; and
- b) Comma (,) has been used as a decimal marker, while in Indian Standards the current practice is to use a point (.) as the decimal marker.

In this standard, reference appears to International Standards for which Indian Standards also exists. The corresponding Indian Standards, which are to be substituted, are listed below along with their degree of equivalence for the edition indicated:

| <i>International Standard</i> | <i>Corresponding Indian Standard</i> | <i>Degree of Equivalence</i> |
|--|--|---------------------------------|
| IEC 60079-0 Explosive atmospheres — Part 0: Equipment — General requirements | IS/IEC 60079-0 : 2017 Explosive Atmospheres: Part 0 Equipment — General requirements (<i>third revision</i>) | Identical |
| IEC 60079-11 Explosive atmospheres — Part 11: Equipment protection by intrinsic safety "i" | IS/IEC 60079 (Part 11) : 2023 Explosive atmospheres: Part 11 Equipment protection by intrinsic safety "i" (<i>second revision</i>) | Identical |
| IEC 60079-14 Explosive atmospheres —Part 14: Electrical installations design, selection and erection | IS 16724 : 2018 Explosive atmospheres — Electrical installations design, selection and erection | Modified/Technically Equivalent |
| IEC 60079-25 Explosive atmospheres — Part 25: Intrinsically safe electrical systems | IS/IEC 60079-25 : 2020 Explosive atmospheres: Part 25 Intrinsically safe electrical systems (<i>second revision</i>) | Identical |

Only the English language text has been retained while adopting it in this Indian Standard, and as such, the page numbers given here are not the same as in the IEC Publication.

For the purpose of deciding whether a particular requirement of this standard is complied with the final value, observed or calculated expressing the result of a test or analysis shall be rounded off in accordance with IS 2 : 2022 'Rules for rounding of numerical values (*second revision*)'. The number of significant places retained in the rounded off value should be the same as that of the specified value in this standard.

CONTENTS

| | | |
|-----|--|----|
| 1 | Scope | 5 |
| 2 | Normative references | 5 |
| 3 | Terms and definitions | 5 |
| 4 | Requirements for 2-WISE devices | 6 |
| 4.1 | General..... | 6 |
| 4.2 | 2-WISE power source ports | 7 |
| 4.3 | 2-WISE power load ports and 2-WISE auxiliary device ports | 7 |
| 4.4 | 2-WISE communication only ports..... | 8 |
| 4.5 | Simple apparatus | 8 |
| 5 | Requirements for 2-WISE systems | 8 |
| 5.1 | General..... | 8 |
| 5.2 | Wiring systems | 9 |
| 5.3 | Powered 2-WISE systems | 9 |
| 5.4 | Communication only 2-WISE systems | 9 |
| 5.5 | Descriptive system document..... | 10 |
| 6 | Schedule drawings and instructions for 2-WISE devices | 10 |
| 7 | Marking | 11 |
| 7.1 | General..... | 11 |
| 7.2 | Examples of marking..... | 11 |
| | Bibliography..... | 14 |
| | Figure 1 – DC-powered 2-WISE system | 9 |
| | Figure 2 – Communication only 2-WISE system | 10 |
| | Table 1 – Intrinsically safe parameters for 2-WISE Power load ports and auxiliary device ports | 7 |
| | Table 2 – Intrinsically safe parameters for 2-WISE communication only ports | 8 |

*Indian Standard***EXPLOSIVE ATMOSPHERES
PART 47 EQUIPMENT PROTECTION BY 2-WIRE INTRINSICALLY
SAFE ETHERNET CONCEPT (2-WISE)****1 Scope**

This part of IEC 60079, which is a technical specification, specifies requirements for the construction, marking and documenting of apparatus, systems and installations for use with the 2-Wire Intrinsically Safe Ethernet concept (2-WISE), such as the physical layer specification for 2-Wire Ethernet 10BASE-T1L as defined in IEEE 802.3cg.

2-WISE is a concept for an advanced physical layer (APL), designed to simplify the examination process for intrinsic safety parameters of components and cabling within APL segments. This is achieved by defining universal intrinsic safety parameter limits for APL ports, according to the specific hazardous area requirements and listing a concise set of rules for the segment setup.

The requirements for construction and installation of 2-WISE devices and systems are included in IEC 60079-11, IEC 60079-14, and IEC 60079-25, except as modified by this document. Parts of a 2-WISE device can be protected by any Type of Protection listed in IEC 60079-0 appropriate to the EPL for the intended hazardous area. In these circumstances, the requirements of this technical specification apply only to intrinsically safe circuits of the apparatus.

Where a requirement of this document conflicts with a requirement of IEC 60079-0, IEC 60079-11, IEC 60079-14 or IEC 60079-25, the requirements of this document take precedence.

2 Normative references

The following documents are referred to in the text in such a way that some or all of their content constitutes requirements of this document. For dated references, only the edition cited applies. For undated references, the latest edition of the referenced document (including any amendments) applies.

IEC 60079-0, *Explosive atmospheres - Part 0: Equipment - General requirements*

IEC 60079-11, *Explosive atmospheres - Part 11: Equipment protection by intrinsic safety "i"*

IEC 60079-14, *Explosive atmospheres - Part 14: Electrical installations design, selection and erection*

IEC 60079-25, *Explosive atmospheres - Part 25: Intrinsically safe electrical systems*

3 Terms and definitions

For the purposes of this document, the terms and definitions given in IEC 60079-0, IEC 60079-11, IEC 60079-14, IEC 60079-25 and the following apply.

ISO and IEC maintain terminological databases for use in standardization at the following addresses:

- IEC Electropedia: available at <http://www.electropedia.org/>
- ISO Online browsing platform: available at <http://www.iso.org/obp>

3.1

10BASE-T1L

physical layer standard for 10 Mb/s Ethernet communication over a single balanced twisted-pair copper cabling with optional provision of power

Note 1 to entry: This is standardized in IEEE 802.3cg.

3.2

Advanced Physical Layer

APL

physical layer based on 10BASE-T1L

3.3

2-Wire Intrinsically Safe Ethernet

2-WISE

intrinsically safe electrical devices and system based on APL with standardized limits for intrinsic safety parameters at each port

3.4

2-WISE device

electrical equipment, either intrinsically safe apparatus or associated apparatus, that provides at least one 2-WISE compliant port

3.5

2-WISE system

assembly of interconnected items of 2-WISE devices, described in a descriptive system document, in which the circuits or parts of the circuits, intended to be used in an explosive atmosphere, are intrinsically safe circuits

3.6

Ports

3.6.1

power source port

port which in addition to communication feeds DC power into an APL segment

3.6.2

power load port

port which in addition to communication consumes DC power from an APL segment

3.6.3

communication only port

port which provides communication only and does not feed or consume significant power in normal operation

3.6.4

auxiliary device port

port of a 2-WISE device that provides functions other than communication

Note 1 to entry: 2-WISE devices with an auxiliary port can comprise a power load or introduce communication signal insertion losses. A surge protector is such a device.

3.7

APL segment

interconnection of a power source port and a power load port or, alternatively, two communication only ports within a 2-WISE system

4 Requirements for 2-WISE devices

4.1 General

2-WISE devices shall conform to the relevant requirements of IEC 60079-11, except as modified by this document. 2-WISE devices shall be suitable for use in a 2-WISE system in accordance with this document.

Each port shall conform to the requirements of 4.2, 4.3 or 4.4.

If a termination network is present inside a 2-WISE power source port, power load port or communication only port, which is additional to the specified maximum output values allowed for 2-WISE, presenting a capacitance at the port connection facilities, the effective value of the capacitance shall not exceed 2,2 μF when the capacitance is protected by a series resistor of minimum value 90 Ω . Other equivalent combinations of capacitance and resistance may also be selected according to the permitted reduction of effective capacitance when protected by a series resistance requirements of IEC 60079-11.

NOTE The dielectric strength requirements for the insulation between the terminals of 2-WISE ports and the frame of the 2-WISE device or parts which are earthed are identical to those required in IEC 60079-11 between an intrinsically safe circuit and the frame of the electrical equipment or parts which are earthed.

4.2 2-WISE power source ports

Each 2-WISE power source port may have a linear or a non-linear output characteristic. The maximum output voltage U_o shall be in the range of 14 V to 17,5 V under the conditions specified in IEC 60079-11 for the respective Level of Protection.

The maximum voltage U_o is the sum of the DC supply voltage and the communication voltage. The maximum internal capacitance C_i and inductance L_i shall be not greater than 5 nF and 10 μH , respectively.

The maximum output current I_o for any 2-WISE power source port shall be determined in accordance with IEC 60079-11 and shall not exceed 380 mA.

The maximum output power P_o shall not exceed 5,32 W.

NOTE 1 Voltage and current limits for 2-WISE power source ports with a rectangular output characteristic can be found in IEC 60079-11 for the Fieldbus Intrinsically Safe Concept (FISCO) – apparatus requirements.

NOTE 2 Possible opening, shorting and earthing of field wiring connected to the port is also taken into account for the determination of the electrical parameters of a 2-WISE power source port.

4.3 2-WISE power load ports and 2-WISE auxiliary device ports

The following requirements apply to 2-WISE power load ports and 2-WISE auxiliary device ports connected to an intrinsically safe system whether installed inside or outside the hazardous area, in addition to the relevant clauses of IEC 60079-11.

The electrical parameters for 2-WISE power load ports and 2-WISE auxiliary device ports shall meet the values given in Table 1.

Table 1 – Intrinsically safe parameters for 2-WISE Power load ports and auxiliary device ports

| | | 2-WISE power load port | 2-WISE auxiliary device port |
|--|-------|------------------------|------------------------------|
| Maximum input voltage | U_i | 17,5 V | 17,5 V |
| Maximum input current | I_i | 380 mA | 380 mA |
| Maximum input power | P_i | 5,32 W | 5,32 W |
| Maximum internal capacitance | C_i | 5 nF | 5 nF |
| Maximum internal inductance | L_i | 10 μH | 200 nH |
| Maximum leakage current | | 1 mA | 50 μA |
| The values given above apply for all equipment groups. | | | |

Under normal or fault conditions as specified in IEC 60079-11 for the respective Level of Protection, the connection facilities of 2-WISE load and auxiliary device ports shall not be a source of energy to the system except for a leakage current not exceeding the values given in Table 1.

4.4 2-WISE communication only ports

2-WISE communication only ports shall have a linear output characteristic.

The electrical parameters for 2-WISE communication only ports, connected to an intrinsically safe system, shall meet the values given in Table 2.

Table 2 – Intrinsically safe parameters for 2-WISE communication only ports

| | | |
|---|-------|------------|
| Maximum output voltage | U_o | 9 V |
| Maximum output current | I_o | 112,5 mA |
| Maximum output power | P_o | 254 mW |
| Maximum input voltage | U_i | 17,5 V |
| Maximum input current | I_i | 380 mA |
| Maximum input power | P_i | 5,32 W |
| Maximum internal capacitance | C_i | 5 nF |
| Maximum internal inductance | L_i | 10 μ H |
| NOTE The values of U_i , I_i and P_i are designed to prevent unintentional damage of an communication only port, if it is accidentally connected to a powered port. | | |

4.5 Simple apparatus

The internal inductance L_i and internal capacitance C_i of each simple apparatus connected to a 2-WISE system shall be less than 1 μ H and 1 nF respectively.

With the exception of the marking requirements found in Clause 7, simple apparatus shall comply with all relevant requirements of this document and of IEC 60079-11.

5 Requirements for 2-WISE systems

5.1 General

A typical 2-WISE system comprises two 2-WISE ports connected to the opposite ends of a cable, with a maximum of two 2-WISE devices with 2-WISE auxiliary device ports in between.

There are two different types of 2-WISE systems:

- the communication only system; and
- the powered system.

The common function is communication. The powered system provides additional supply power in the following manner:

- the power source port supplies DC power to the system, and the power load port consumes DC power from the system. Auxiliary device ports may also consume DC power from the system.
- in an communication only system no DC power is provided to the system via the 2-WISE connection and in this case 2-WISE devices are always separately powered. A communication only port shall not be connected to a power source port.

Simple apparatus according to 4.5 may be added to a 2-WISE system without modifying the safety assessment of the system.

The total inductance and capacitance of all simple apparatus connected to a 2-WISE system shall not exceed 10 μ H and 5 nF respectively.

NOTE 1 2-WISE connection facilities or electromechanical switches are considered as simple apparatus according to 4.5 but do not contribute to the total inductance and capacitance.

NOTE 2 For functional reasons, the cable (stubs) for connecting 2-WISE devices with auxiliary device ports in parallel to the 2-WISE system, will be less than 1 m, and are not considered to be part of the total cable length of the 2-WISE system.

5.2 Wiring systems

The cable used in a 2-WISE system shall comply with the following parameters:

- cable resistance R_C : 15 Ω /km to 150 Ω /km;
- cable inductance L_C : 0,4 mH/km to 1 mH/km;
- cable capacitance C_C : 45 nF/km to 200 nF/km;

NOTE 1 The installation and constructional requirements of individual cables and multi-circuit cables carrying more than one intrinsically safe circuit are contained in IEC 60079-25.

NOTE 2 For the determination of cable parameters see IEC 60079-25.

5.3 Powered 2-WISE systems

A DC-powered 2-WISE system shall be considered intrinsically safe if one 2-WISE source port, one 2-WISE power load port and up to two 2-WISE auxiliary device ports are connected with a cable of maximum length 200 m, according to the above specification and as shown in Figure 1.

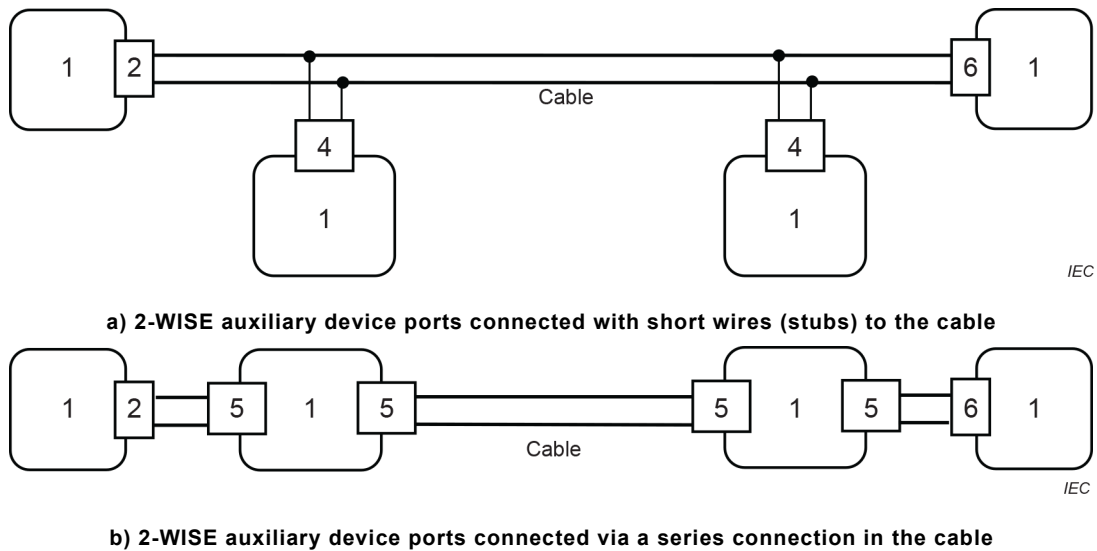

Key

- 1 2-WISE device
- 2 2-WISE power source port
- 4 2-WISE auxiliary device port
- 5 2-WISE auxiliary device port that is physically split into two termination facilities, but electrically connected through and therefore counted as one 2-WISE auxiliary device port per 2-WISE device
- 6 2-WISE power load port

Figure 1 – DC-powered 2-WISE system

5.4 Communication only 2-WISE systems

A communication only 2-WISE system shall be considered intrinsically safe if two 2-WISE communication only ports and up to two 2-WISE auxiliary device ports are connected with a cable of maximum length 1 000 m, according to 5.2 and as shown in Figure 2.

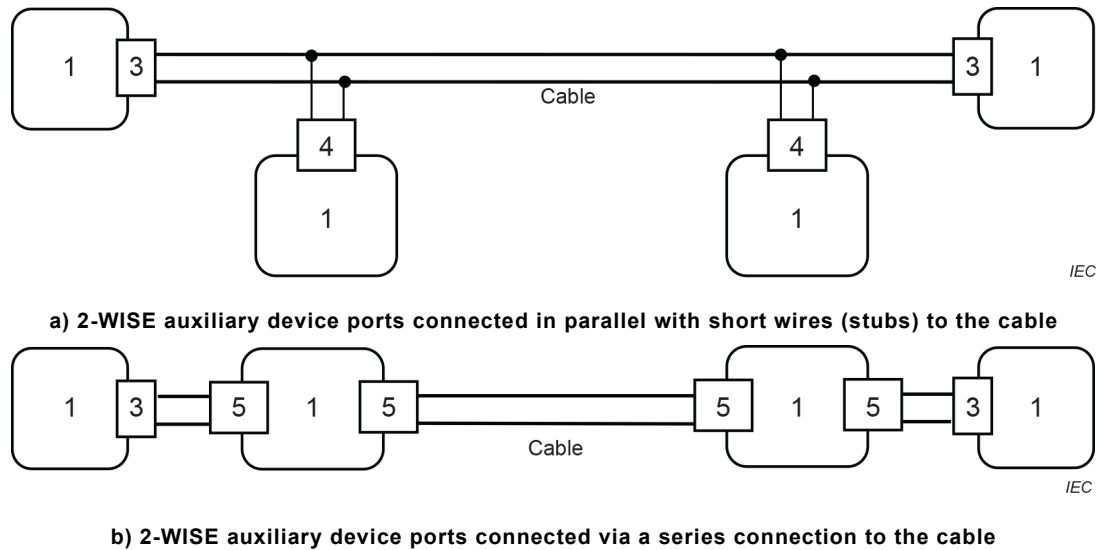

Key

- 1 2-WISE device
- 3 2-WISE communication only port
- 4 2-WISE auxiliary device port
- 5 2-WISE auxiliary device port that is physically split in two termination facilities but electrically connected through and therefore counted as one 2-WISE auxiliary device port per 2-WISE device

Figure 2 – Communication only 2-WISE system

5.5 Descriptive system document

Each interconnection of 2-WISE ports in a 2-WISE system shall be allocated a Level of Protection (for example "ia", "ib" or "ic") determined by the 2-WISE port with the lowest Level of Protection and be allocated an equipment group (for example I, IIA, IIB, IIC, IIIA, IIIB or IIIC) determined by the 2-WISE port with the least onerous equipment group. This shall be documented in the descriptive system document.

The descriptive system document shall contain the confirmation that the permitted maximum ambient temperature of each 2-WISE device is suitable for the intended use.

The temperature class of each 2-WISE device shall be determined and recorded in the descriptive system document, if applicable.

The descriptive system document shall include the parameters of the cable (see 5.2) to be connected to a 2-WISE port.

NOTE IEC 60079-25 provides an example of a descriptive system document.

6 Schedule drawings and instructions for 2-WISE devices

These requirements supplement and modify the schedule drawings and instructions requirements of IEC 60079-0 and IEC 60079-11.

The schedule drawings shall confirm that each 2-WISE device is suitable for use in a 2-WISE system in accordance with this technical specification.

The intrinsic safety parameters need not be included in the certificate or in the instructions for the 2-WISE ports.

Instructions shall contain information indicating that a marked "2-WISE communication only port" shall not be connected to a "2-WISE power source port".

Instructions shall provide the necessary information to produce the descriptive system document.

7 Marking

7.1 General

These requirements supplement and modify the marking requirements of IEC 60079-0 and IEC 60079-11.

Each 2-WISE device shall be marked "2-WISE".

The type of each port shall be clearly marked, as:

- "2-WISE power source"
- "2-WISE power load"
- "2-WISE auxiliary device"
- "2-WISE communication only"

2-WISE ports need not be marked with the intrinsic safety parameters U_i , I_i , C_i , L_i , P_i , U_o , I_o , C_o , L_o or P_o .

7.2 Examples of marking

a) 2-WISE device with power source port:

Model 123 APL switch
 ABC Company
 2-WISE
 Ex ec [ia Ga] IIC T4 Gc
 Ex tc [ia Da] IIIC T130°C Dc
 2-WISE power source
 $-55\text{ °C} \leq T_a \leq +100\text{ °C}$
 Serial No. 12345
 N.A. 20.1111

b) 2-WISE device with power load port:

Model 456
 ABC Company
 2-WISE
 Ex ib IIC T4 Gb
 Ex ib IIIC T130°C Db
 2-WISE power load
 $-20\text{ °C} \leq T_a \leq +60\text{ °C}$
 Serial No. 5432
 N.A. 20.2222

c) 2-WISE device with auxiliary device port:

Model 789
 ABC Company
 2-WISE
 Ex ic IIA T1 Gc

Ex ic IIIA T450°C Dc
2-WISE auxiliary device
-40 °C ≤ Ta ≤ +100 °C
Serial No. TW342
N.A. 20.3333

.....
.....

d) 2-WISE device with communication only port:

Model 1000
ABC Company
2-WISE
Ex ec [ia Ga] IIC T4 Gc
Ex tc [ia Da] IIIC T130°C Dc
2-WISE communication only
- 55 °C ≤ Ta ≤ +85 °C
Serial No. AB567
N.A. 20.4444

.....
.....

e) 2-WISE apparatus with multiple 2-WISE ports:

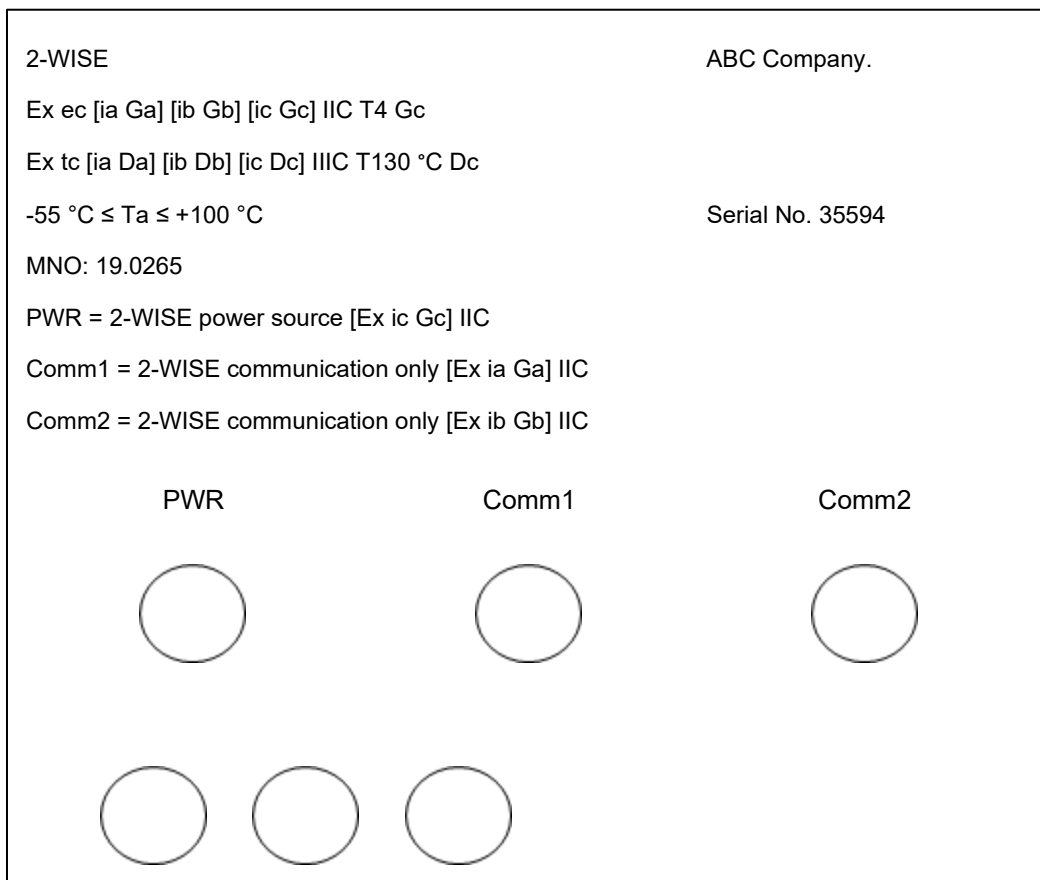

f) 2-WISE device with 2-WISE auxiliary device ports and a power load port

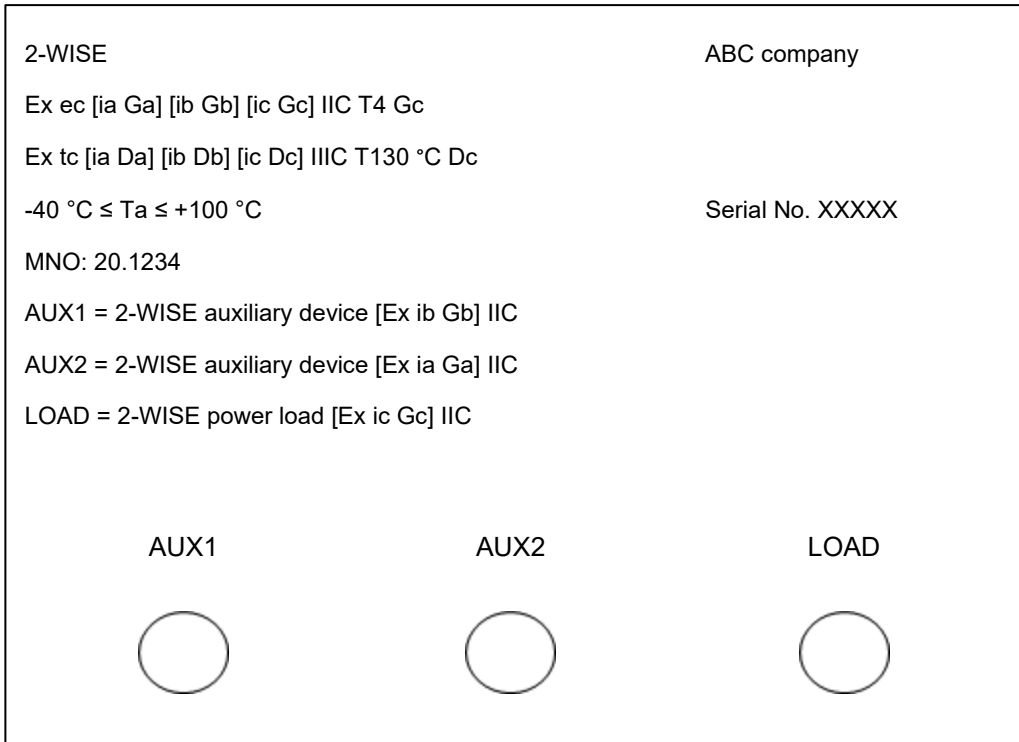

Bibliography

IEEE 802.3cg, *IEEE Standard for Ethernet – Amendment 5: Physical Layer Specifications and Management Parameters for 10 Mb/s Operation and Associated Power Delivery over a Single Balanced Pair of Conductors*

IEC 60050-426, *International Electrotechnical Vocabulary (IEV) – Part 426: Explosive atmospheres*

Bureau of Indian Standards

BIS is a statutory institution established under the *Bureau of Indian Standards Act, 2016* to promote harmonious development of the activities of standardization, marking and quality certification of goods and attending to connected matters in the country.

Copyright

BIS has the copyright of all its publications. No part of these publications may be reproduced in any form without the prior permission in writing of BIS. This does not preclude the free use, in the course of implementing the standard, of necessary details, such as symbols and sizes, type or grade designations. Enquiries relating to copyright be addressed to the Head (Publication & Sales), BIS.

Review of Indian Standards

Amendments are issued to standards as the need arises on the basis of comments. Standards are also reviewed periodically; a standard along with amendments is reaffirmed when such review indicates that no changes are needed; if the review indicates that changes are needed, it is taken up for revision. Users of Indian Standards should ascertain that they are in possession of the latest amendments or edition by referring to the website-www.bis.gov.in or www.standardsbis.in.

This Indian Standard has been developed from Doc No.: ETD 22 (24724).

Amendments Issued Since Publication

| Amend No. | Date of Issue | Text Affected |
|-----------|---------------|---------------|
| | | |
| | | |
| | | |
| | | |

BUREAU OF INDIAN STANDARDS

Headquarters:

Manak Bhavan, 9 Bahadur Shah Zafar Marg, New Delhi 110002

Telephones: 2323 0131, 2323 3375, 2323 9402

Website: www.bis.gov.in

Regional Offices:

Central : 601/A, Konnectus Tower -1, 6th Floor,
DMRC Building, Bhavbhuti Marg, New
Delhi 110002

Telephones

{ 2323 7617

Eastern : 8th Floor, Plot No 7/7 & 7/8, CP Block, Sector V,
Salt Lake, Kolkata, West Bengal 700091

{ 2367 0012
2320 9474

Northern : Plot No. 4-A, Sector 27-B, Madhya Marg,
Chandigarh 160019

{ 265 9930

Southern : C.I.T. Campus, IV Cross Road, Taramani, Chennai 600113

{ 2254 1442
2254 1216

Western : Manakalya, 4th Floor, NTH Complex (W Sector), F-10, MIDC, Andheri
(East), Mumbai 400093

{ 283 25838

Branches : AHMEDABAD, BENGALURU, BHOPAL, BHUBANESHWAR, CHANDIGARH, CHENNAI, COIMBATORE, DEHRADUN, DELHI, FARIDABAD, GHAZIABAD, GUWAHATI, HARYNA, HUBLI, HYDERABAD, JAIPUR, JAMMU & KASHMIR, JAMSHEDPUR, KOCHI, KOLKATA, LUCKNOW, MADURAI, MUMBAI, NAGPUR, NOIDA, PARWANOO, PATNA, PUNE, RAIPUR, RAJKOT, SURAT, VIJAYAWADA.