

कागज़ और लुगदी आधारित पैकेजिंग  
सामग्री — परीक्षण पद्धतियाँ

भाग 2 गंध, प्लाई पृथक्करण, पंचर और  
रिड्यूसिबल सल्फर  
( दूसरा पुनरीक्षण )

**Paper and Pulp Based Packaging  
Materials — Methods of Test**  
**Part 2 Odour, Ply Separation, Puncture,  
and Reducible Sulphur**  
( *Second Revision* )

ICS 85.080

© BIS 2024



भारतीय मानक ब्यूरो  
BUREAU OF INDIAN STANDARDS  
मानक भवन, 9 बहादुर शाह ज़फर मार्ग, नई दिल्ली - 110002  
MANAK BHAVAN, 9 BAHADUR SHAH ZAFAR MARG  
NEW DELHI - 110002

[www.bis.gov.in](http://www.bis.gov.in) [www.standardsbis.in](http://www.standardsbis.in)

## FOREWORD

This Indian Standard (Part 2) (Second Revision) was adopted by the Bureau of Indian Standards after the draft finalized by the Paper Based Packaging Materials Sectional Committee, had been approved by the Chemical Division Council.

The packaging materials used in the industry are many and varied. They are paper and paper products, textiles, metal and metal foils, plastics and a variety of laminates, wood, glass and ceramics, cushioning materials, strapping and hooping materials, nails, etc. Among these paper and paper products are of major importance.

This standard is (Part 2) of IS 4006 series of standards which cover methods of tests which are carried out for paper and pulp based packaging materials to evaluate their quality. Other Parts of IS 4006 series are:

- Part 1 Flexural resistance and deflection, waterproofness, water penetration, grease resistance, abrasion loss, blocking resistance, compression resistance, rigidity, stiffness and softness; and air permeance (*second revision*)
- Part 3 Arsenic, total copper, total iron, water soluble copper and water soluble iron (*second revision*)

In first revision, the procedure for measuring the flat crushing resistance was deleted since that method applies only to corrugated boards and was incorporated in IS 7063 (Part 2). Spectrophotometric method for the determination of reducible sulphur was incorporated to serve as a referee method.

This revision has been brought out to bring the standard in the latest style and format of Indian Standards. References have been updated too.

The composition of Committee responsible for formulation of this standard is given in [Annex B](#).

For the purpose of deciding whether a particular requirement of this standard is complied with, the final value, observed or calculated, expressing the result of a test or analysis, shall be rounded off in accordance with IS 2 : 2022 'Rules for rounding off numerical values (*second revision*)'. The number of significant places retained in the rounded off value should be the same as that of the specified value in this standard.

*Indian Standard*

**PAPER AND PULP BASED PACKAGING  
MATERIALS — METHODS OF TEST  
PART 2 ODOUR, PLY SEPARATION, PUNCTURE,  
AND REDUCIBLE SULPHUR**  
( *Second Revision* )

**1 SCOPE**

**1.1** This standard prescribes methods for the following tests for paper and pulp based packaging materials:

- a) Odour;
- b) Ply separation;
- c) Puncture; and
- d) Reducible sulphur.

**1.2** If there is any inconsistency between the requirements of this standard and those of the standard for an individual material, the later shall prevail.

**2 REFERENCES**

The standards listed in [Annex A](#) contain provisions, which through reference in this text, constitute provisions of this standard. At the time of publication, the editions indicated were valid. All standards are subject to revision and parties to agreements based on this standard are encouraged to investigate the possibility of applying the most recent edition of these standards.

**3 TERMINOLOGY**

For the purpose of this standard, the definitions given in IS 4261 shall apply.

**4 SAMPLING**

Representative samples for test shall be drawn as prescribed in IS 1060 (Part 1).

**5 CONDITIONING OF TEST SPECIMENS**

Unless specified otherwise in the individual test methods, all the test specimens shall be conditioned according to IS 1060 (Part 1).

**6 QUALITY OF REAGENTS**

Unless otherwise specified, pure chemicals and distilled water (*see* IS 1070) freshly boiled and cooled, shall be employed in the tests.

NOTE — 'Pure chemicals' shall mean chemicals that do not contain impurities which affect the results of analysis.

**7 ODOUR****7.1 General**

This procedure specifies the methods that may be employed in assessing the risk of odour from packaging materials causing complaint with packaged foods, drugs, etc. The combined sensations of smell and taste are generally described by the term 'flavour' and whenever a food possesses an 'off flavour' due to acquiring adventitious substances it may be described as 'tainted'. The detection methods prescribed here are concerned with odour and flavour derived from volatile constituents contained in packaging materials. Taint can also be caused by other means, such as the extraction of non-volatile constituents from packaging materials by direct contact with the food but these procedures are not concerned with any form of taint other than that produced by odorous volatile constituents in packaging materials. The recognition of odour or taint is subjective process occurring within the brain of an individual. Hence they are not objective qualities and cannot be assessed without the judgement of a human observer.

**7.2 Test Panel**

It is desirable to organize a test panel, which may consist of four to eight members, selected carefully from those who have demonstrated an acute and discerning sense of smell. The senses of taste and odour are closely allied and members of the panel should also be tested thoroughly for taste sensitivity and differentiation. Taste is a useful method of detecting odours as described under [7.6](#).

**7.3 Sample Containers and Testing Room****7.3.1 Sample Containers**

Vapour proof containers may be necessary for sampling, storage and holding test pieces for the development of maximum intensity of odour. Containers shall be clean, dry and free from odour. Aluminium foil or cellulose film shall be substituted for any rubber gaskets or stoppers. Samples may also be wrapped directly in foil, cellulose film or vegetable parchment.

### **7.3.2 Testing Room**

Shall be free from plant or industrial odours. Extremes of temperatures should be avoided, except in special cases and all distracting influences should be minimized.

## **7.4 Materials**

### **7.4.1 Standard Samples**

In some instances, standard samples, representing satisfactory and maximum permissible levels of odour, may be set up. Maintenance of the samples is a serious problem, since age and other factors may alter odour drastically. In all cases, it is desirable to have some type of reference sample available.

### **7.4.2 Water (Odour Free)**

Moisture is commonly used to intensify odours, or develop potential odours. Normally, tap water is satisfactory, except where residual odour or a chlorine smell is present. Distilled water is not always odourless. Each portion of water shall be smelled and tasted before acceptance.

### **7.4.3 Fatty Materials**

A range of substances containing oil or fat may be used to pick up certain types of odours, with identification and degree of odour determined both by smell and taste. Common materials are mineral oil, milk chocolate, cream, and fresh unsalted butter.

## **7.5 Test Specimen**

The preparation of the test sample for presentation to the panel is very important. No one standard method of doing this is sufficient, since the type of materials under test and the possible odours present, allow a wide range of possibilities. A few of the methods which have been used are given in [7.5.1](#) to [7.5.3](#) as a guide; others may be devised as necessary. Each laboratory should develop and record the detailed preparation procedure found satisfactory for specific products.

### **7.5.1 Direct Testing**

Cut or tear representative samples of the packaging materials to a convenient size. It is often desirable to open up fresh surfaces at the instant of smelling (tearing paperboard, scraping wax with a knife, breaking open glue joint, etc).

### **7.5.2 Moistening**

Water brings out some types of odours by various mechanisms, and especially when the product may be subjected to moisture, try one of the following.

### **7.5.2.1 Breathing on the sample**

The tester exhales on the test piece, then smells it.

### **7.5.2.2 Dampening**

Sprinkle the sample lightly with water, then smell. Time is sometimes required to develop an odour. Normally, the test piece is dampened, at 21 °C to 27 °C and stored at 38 °C, in an odourless glass jar for 24 h and then tested.

### **7.5.2.3 Soaking**

Saturate or submerge the test piece in water for a period of time and at a temperature judge a suitable for each case. Test by smelling both the water and the test piece.

## **7.5.3 Transfer to Oily Product**

**7.5.3.1** Place the test piece in a covered glass dish adjacent but not in contact with mineral oil for 4 h to 24 h at room temperature. Oil soluble materials, such as printing ink, kerosine, etc, can be detected by smelling the oil.

**7.5.3.2** Prepare three sandwiches with a part of unsalted butter between two pieces of test piece and overwrap with parchment, cellulose film or foil. Hold for 1 day, 2 day and 3 day, respectively, at room temperature; refrigerate for 30 min; then taste and smell the butter. Reference samples may be prepared using odour free parchment.

**7.5.3.3** Place the folded sample in a watertight tray and add 3 cm depth of coffee cream (18 percent butter fat). Cover with aluminium foil, hold at 7 °C for 24 h, then taste the cream. This procedure is used widely for printing ink odours and is very sensitive. As an alternative, strips of material may be placed in a dish or flask and covered with cream. Run a blank test on cream in a glass bottle with a foil cap.

**7.5.3.4** Place the test piece in a covered glass dish adjacent to a piece of plain milk chocolate, and hold at room temperature for 1 day to 2 day. Taste the chocolate and compare with a control.

**7.5.3.5** Prepare a package by wrapping same commercial product, known to be sensitive to odour, with the test piece materials. Hold for the desired time and temperature, then smell and taste the product in comparison with a control.

## **7.6 Procedure**

Samples shall be identified only by code numbers, including the control, and tests should be given only the minimum amount of information prior to the test. Each member shall be given a set of test pieces and

a report form, and they shall work independently. [Table 1](#) may serve as a procedural guide.

### 7.7 Report

Each individual panel member shall report independently. Complete agreement by the panel may be expected but the group report serves as valuable data.

#### 7.7.1 Unknown Odour

Type, its chemical nature and origin (if possible).

#### 7.7.2 Known Odour — Rated as:

- a) essentially none (pleasant);
- b) slight but not objectionable (neutral);
- c) moderate, objectionable (unpleasant); and
- d) strong (offensive).

#### 7.7.3 Taste as Odour Index

The same reporting system shall be used as for smelling.

## 8 PLY SEPARATION OF COMBINED CONTAINER BOARD

### 8.1 General

This method evaluates the resistance to ply separation of laminated solid fibre or combined corrugated board fabricated with water resistant adhesives.

### 8.2 Apparatus

**8.2.1 Water Tank** — of corrosion-resisting metal. Suggested minimum dimensions are 40 cm length, 30 cm breadth and 25 cm height. Rods for holding the test pieces 25 mm under the surface of the water are attached 20 cm from the bottom of the tank and 5 cm from each of the 40 cm sides. Some means for keeping the test pieces separated from each other and from the side walls of the tank should be provided.

**8.2.2** The tank shall be thoroughly washed for each test. Soap shall not be used for washing since any residue will seriously affect the test.

**Table 1 Common Packing Materials, Odours and Detection Methods**

(Clause [7.6](#))

SI No.	Material	Type of Odour	Methods of Tests, Ref to
(1)	(2)	(3)	(4)
i)	Synthetic film	Inherent solvent Plasticizer Monomer, etc	<a href="#">7.5.1</a> (24 h at 38 °C) <a href="#">7.5.3.1</a> <a href="#">7.5.3.5</a>
ii)	Paper and board	Inherent kraft Musty or mouldy Chlorinated phenol Sour	<a href="#">7.5.1</a> , <a href="#">7.5.2.1</a> and <a href="#">7.5.2.2</a> <a href="#">7.5.1</a> , <a href="#">7.5.2.1</a> and <a href="#">7.5.2.2</a> <a href="#">7.5.1</a> and <a href="#">7.5.2.3</a> <a href="#">7.5.1</a> and <a href="#">7.5.2</a>
iii)	Paper, coated	Volatile additives, casein decomposition	<a href="#">7.5.1</a>
iv)	Glassine, coated	Inherent in coating	<a href="#">7.5.1</a> (24 h at 38 °C), <a href="#">7.5.3.1</a> and <a href="#">7.5.3.5</a>
v)	Ink and varnish	Oxidizing oils, plasticizer, solvent	<a href="#">7.5.1</a> and <a href="#">7.5.3.3</a>
vi)	Adhesive joints (after thorough drying)	Solvents, sour, starch added perfume	<a href="#">7.5.1</a> (fresh and after 24 h at 38°C)
vii)	Wax	Oil, residual oxidized solvent	<a href="#">7.5.1</a> (fresh shavings at room temperature in small containers); and <a href="#">7.5.3.5</a> (Cheese, for example)

### 8.3 Materials

#### 8.3.1 Water

Potable tap water at a temperature of  $(27 \pm 2)$  °C. It shall have a pH value between 6.5 to 7.5 and shall be drawn fresh for each batch of test pieces. Care shall be exercised to eliminate air in the water.

### 8.4 Test Specimens

**8.4.1** The test Specimens shall preferably be 15 cm × 25 cm in size. At least four test pieces of each sample shall be tested.

**8.4.2** The sample shall be allowed to cure in an atmosphere of  $(65 \pm 2)$  percent relative humidity at a temperature of  $(27 \pm 2)$  °C for at least one week from the time of manufacture before test. For control purposes, at the time of manufacture a quick test of board may be made by accelerated curing in an oven for 10 min to 20 min at a temperature of 105 °C prior to placing the test pieces in water.

### 8.5 Procedure

Submerge the test pieces vertically within 25 cm edges horizontal and the top edge 25 mm below the surface of the water. Support the test pieces so that the water has free access to all surfaces and ply separation is not restricted. After immersion for  $(24 \pm 0.25)$  h, remove the test pieces from the tank and soak off excess surface water by suitable means, such as blotters or paper towels. Examine the test pieces immediately for ply separation and satisfactory bonding. Should some separation of the component plies appear at the edge of the board, such separation shall not extend more than 6 mm from the edge when flexed by pressure from the thumb. The plies must not be forced apart. They should be flicked lightly at the edge with the thumb. All other areas shall be satisfactorily bonded.

### 8.6 Report

The report shall include the following:

- a) Number of test pieces tested;
- b) Number of test pieces which failed; and
- c) Dimensions of the test pieces.

## 9 PUNCTURE TEST

### 9.1 General

This method covers the procedure for puncture test of paper board, corrugated and solid fibreboard. The test is a measure of the energy required to force a puncture head of designated size and shape

completely through a sample of fibreboard. The measured value is dependent upon the resistance to puncture at the stiffness of the board.

### 9.2 Apparatus

Beach puncture test apparatus, consisting of the parts given in [9.2.1](#) to [9.2.9](#).

#### 9.2.1 Pendulum

Incorporating an arm in the form of an arch of 90°.

#### 9.2.2 Puncture Point

Affixed to the end of the arm and having the shape of a right angled triangular pyramid 25 mm in height, base edges left sharp with round leading edges and point honed to  $(1.57 \pm 0.05)$  mm radius.

#### 9.2.3 Puncture Point Collar

Loose fitting around the base of the puncture point to eliminate friction that would result if the punctured material rubbed against the puncture arm.

#### 9.2.4 Trigger or Latch

To hold the pendulum in the horizontal position.

#### 9.2.5 Clamping Plates

Spring actuated, for holding the test piece rigidly at the level of axis of the pendulum.

#### 9.2.6 Pointer and Scale

To indicate the arc through which the pendulum travels after penetrating through the test piece.

#### 9.2.7 Weights

Which when attached, give a maximum scale value of at least 1 300 units of energy when the pendulum is in the horizontal position and scale graduations to correspond to the weights used.

#### 9.2.8 Loose Plate

Inserted between the clamping plates when testing the material for the purpose of defining the test area. This plate shall be removed when checking the zero reading of the apparatus.

#### 9.2.9 Adjustable Screw

Bearing against the pointer assembly during the measuring half of the pendulum swing, which permits adjustment of the full scale position of the pointer.

### 9.3 Adjustment for Calibration of Apparatus

**9.3.1** Place the apparatus on a rigid heavy foundation of convenient height and level it in both the horizontal directions.

**9.3.2** Before starting calibration of the apparatus it is important that the entire clamping assembly should be unbolted and moved away from the path of pendulum.

**9.3.3** To check the zero reading, remove the weights and the stud that supports the weight. Set the pointer at full scale position before releasing the pendulum from the cocked position. After the pendulum has completed its swing, the pointer should not be more than 3.2 mm above the zero position. An error of more than 3.2 mm indicates excessive friction which can be adjusted by relieving the spring pressure between the pointer collar and the shaft. The pressure is governed by the positions of the screw in the stud projecting from the pointer hub.

**9.3.4** Check the friction of the pointer by the latching the bare pendulum, without the weights or weight

stud, and with the collar attached to the puncture head. Set the pointer at full scale position before releasing the pendulum from the cocked position. After the pendulum has completed its swing, the pointer should not be more than 3.2 mm above the zero position. An error of more than 3.2 mm indicates excessive friction which can be adjusted by relieving the spring pressure between the pointer collar and the shaft. The pressure is governed by the positions of the screw in the stud projecting from the pointer hub.

**9.3.5** The puncture point collar is held in place on the base of the puncture head by a pin containing a small ball under spring pressure. The position of this pin in the puncture head base is adjustable and can be locked by means of a set screw. The position of this pin and ball should be such that the loose sleeve is very lightly held on the base of the puncture head, and can be removed with a minimum of energy. One of the three possible positions of collar on the base is chosen and marked on the side for use of collar always in the same position.

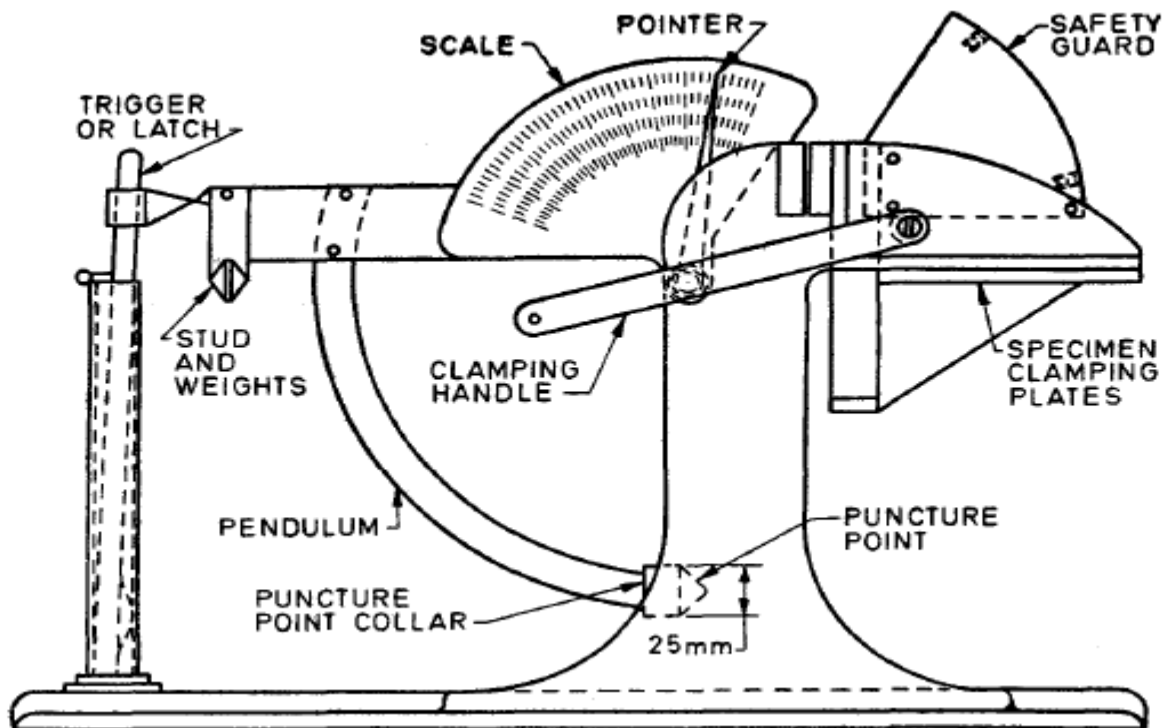

FIG. 1 PUNCTURE TESTER

## 9.4 Procedure

**9.4.1** Place the conditioned test piece between the clamping plates. Before making each test, place the puncture point collar on the base of the puncture head and set the pointer about 25 mm above the expected reading. Raise the pendulum to the horizontal position. Release by pushing the latch handle to the left. Note the reading on the proper scale after the pendulum has completed its swing. This reading should be made to the nearest one-half division of the scale used. It is not advisable to make tests giving values within 25 percent of the upper or lower end of the scale. In such cases use another suitable scale.

**9.4.2** Orient the test pieces in such a manner that the edge of the puncture point, which is in the plane of the puncture arm, is perpendicular to the corrugations of combined corrugated, or grain direction of the uncombined sheets, in half the number of test pieces. Make equal number of tests with either surface of the board facing up. On uncombined board or single face corrugated board, make all tests with smooth surface down.

## 9.5 Report

The report for puncture test shall include the following:

- a) Room temperature and relative humidity;
- b) Scale used;
- c) Number of tests made each way of material;
- d) Average results for test made each way of the material;
- e) Total average results, accurate to 2 kgf.cm if the average value is more than 100 kgf.cm, accurate to 1 kgf.cm, if the average value is between 50 and 100 and to nearest 0.5 kgf.cm, if the average value is less than 50 kgf.cm; and
- f) Maximum and minimum values obtained.

NOTE — 1 beach unit = 0.305 cm kg.

## 10 REDUCIBLE SULPHUR

### 10.1 General

This method describes a quantitative and a semi-quantitative procedure for the determination of reducible sulphur in paper and paper board. The semi-quantitative test indicates the general level of reducible sulphur with limited accuracy while the quantitative procedure yields results of much greater accuracy.

**10.1.1** The methods outlined are not necessarily a measure of how much a given test material will tarnish polished metals. When tested by this method, paper which has less than 0.000 8 percent reducible sulphur may be assumed to be non-tarnishing as far as sulphur is concerned, but if more than 0.000 8 percent, this does not necessarily mean tarnishing will occur, because sulphur compounds which may not cause staining are reduced by the treatment with the subsequent evolution of hydrogen sulphide.

**10.1.2** If the pH of the paper is low, that is, 4 to 4.5 (cold extraction), as little as 0.000 2 percent of reducible sulphur may cause tarnishing of initiation gold bronze prints; whereas, if the pH were higher, for example, on brush-coated art paper, a much higher quantity of sulphur might be tolerated.

**10.1.3** The procedures described do not give the total sulphur content, nor the total reducible sulphur content, nor are they intended to. They are limited to the reducible sulphur content determined under the conditions of the test (for instance a fairly mild reduction system). Those forms of sulphur believed to be 'reducible' under the test condition are (a) sulphide (released by the acid, not actually reduced), (b) elemental sulphur, (c) thiosulphate, (d) other polythionates or polysulphides, (e) perhaps sulphide. Sulphate is excluded.

**10.1.4** Great care shall be taken to avoid possible contamination of the reagents and test pieces by contact with the bare fingers or minute quantities of sulphur compounds being absorbed from the atmosphere. It is advisable to run a blank test using the same apparatus and reagents to ascertain that they do not contain, nor have acquired any appreciable quantity of sulphur.

### 10.2 Quantitative Method

#### 10.2.1 Apparatus

##### 10.2.1.1 Reaction apparatus

Consisting of a 500 ml round bottomed three necked flask, equipped with a gas inlet tube adapter with perforated bulb, a 60 ml pear-shaped funnel (dropping funnel), a 200 mm condenser with a side-arm adapter. A heating mantle with variable power supply forms part of the reaction apparatus.

**10.2.1.2 Absorption apparatus** — Consisting of a 100 ml amber or low actinic flask in a suitable ice bath.

**10.2.1.3 Colorimeter or spectrophotometer** — To read at 660 nm to 670 nm equipped with 20 mm to 50 mm cuvettes.



**10.2.1.4 Pipettes** — 1 ml, 2 ml, 5 ml, 10 ml serological or bacteriological (blow out)

**10.2.1.5 Disintegrator** — A blender or other such rotating blade device

**10.2.1.6 Water bath** — At 100 °C or steam bath

## 10.2.2 Reagents

**10.2.2.1 Aluminium foil** — Not over 0.25 mm thick, sulphur free

**10.2.2.2 Phosphoric acid** — 85 percent, sulphur free

### 10.2.2.3 Cadmium hydroxide absorption suspension

Dissolve 4.3 g of cadmium sulphate ( $3\text{Cd}\cdot\text{SO}_4\cdot 8\text{H}_2\text{O}$ ) in water; add 0.3 g of sodium hydroxide, dissolved in water and 10 g of arabinogalactan; dilute to 1 000 ml and stir well. This is a saturated solution of cadmium hydroxide; the suspension is swirled before pouring off an aliquot.

### 10.2.2.4 Ferric chloride solution

Dissolve 100 g of ferric chloride hexa hydrate ( $\text{FeCl}_3\cdot 6\text{H}_2\text{O}$ ) in water and dilute to 100 ml.

### 10.2.2.5 Amine Solution:

- a) *Stock amine solution* — Dissolve 25 g of P-amino-dimethylaniline sulphate (that is N, N-dimethyl-P-phenylene diamine sulphate) in 75 ml of cold (1 : 1) sulphuric acid and dilute to 100 ml with the (1 : 1) acid; and
- b) *Dilute amine solution* — Pipette 2.5 ml of the stock solution into a 100 ml volumetric flask and dilute to the mark with (1 : 1) sulphuric acid.

### 10.2.2.6 Sodium sulphide standard solution:

- a) *Stock solution* — Dissolve 0.4 g sodium sulphide nona hydrate ( $\text{Na}_2\text{S}\cdot 9\text{H}_2\text{O}$ ) (use large crystals which appear dry) in water deaerated with nitrogen. Dilute to 250 ml with the deaerated water. After the solution has been diluted to the volume, add 5 ml to 10 ml of cyclohexane to protect the solution from air oxidation. The solution is likely to be stable for one month; and
- b) *Working solution* — (to be prepared daily). Pipette 10.0 ml of stock solution into a 1 000 ml volumetric flask and dilute to the mark with the deaerated water. One ml of this solution contains 2 µg of sulphur.

NOTE — This solution or the stock solution may be standardized by potentiometric titration with silver nitrate solution using a sulphide specific electrode; the sulphide standard should be at least 90 percent pure.

### 10.2.2.7 Nitrogen gas, sulphur free

## 10.2.3 Test Specimen

A minimum of 6 g of sample is required to provide triplicate test specimens. From each test unit of the sample, cut and weigh 2 g to the nearest milligram for each test specimen. Determine the average moisture content of the paper.

## 10.2.4 Procedure

**10.2.4.1** Disintegrate the sample in the blender with 75 ml of water and transfer the test specimen from the disintegrator quantitatively to the 500 ml reaction flask using additional aliquots of 5 ml of water to assist in the transfer. Add 2 g of aluminium foil which has been cut into 13 mm square and complete the assembly of the reaction apparatus.

### 10.2.4.2 Precipitation of cadmium sulphide

Measure 10 ml of the phosphoric acid into the dropping funnel and 75 ml of the cadmium hydroxide absorption suspension (which is swirled before pouring and should include some solids) into the darkened 100 ml volumetric collecting flask. Start bubbling the nitrogen at the rate of about 5 bubbles per second, taking care to ensure that there are no leaks. Use top quality sulphur-free stop cock grease at the joints and if necessary tie the joints with clamp or rubber bands. After the nitrogen has been adjusted, submerge the delivery tube into the absorption suspension in the 100 ml volumetric flask and put the ice bath in place, taking care to ensure that the tip is to the bottom of the flask that is, submerged as deeply as possible. Add the 10 ml of phosphoric acid from the dropping funnel. Leave a small amount of acid in the tip. Close the stop cock on the funnel, and start heating the mixture to a boil. Take care that the absorption solution does not back up in the delivery tube while the mixture is getting heated. It may be necessary to adjust the nitrogen flow to prevent this. Discontinue heating after 45 min, remove the volumetric flask together with the side-arm adapter by dislodging it at the condenser, and stop the nitrogen flow. Keep the adaptor together with the flask until the amine reagent is added in the colour development step because the cadmium sulphide often hangs up in the tube tip. The sample should not be stored in this manner for more than one hour.

### 10.2.4.3 Preparation of calibration standard

(To be prepared each time the analysis is performed.) Add 75 ml of the cadmium hydroxide absorption suspension to each of five 100 ml darkened volumetric flasks and place in the constant temperature bath (20 °C to 25 °C). Pipette 1 ml, 2 ml, 5 ml and 10 ml respectively of the sodium

sulphide standard working solution into four of the volumetric flasks. The standards contain 2 µg, 4 µg, 10 µg and 20 µg of sulphide per 100 ml. The flask containing no sulphide is the reagent blank.

NOTE — The blow-out pipettes are used to pipette the sodium sulphide working solutions aliquots. They are immersed into the absorption solutions and allowed to drain slowly while the tips are below the surface. When drainage is complete, gently blow out the last drops while still immersed and then remove from the flasks.

#### 10.2.4.4 Colour development and read out

To the test solution reagent blank and calibration, standards in 100 ml volumetric flasks, add 2 ml of the diamine solution. Allow the dense amine solution to flow down the side of the flask to the bottom of the absorption solution. Stopper the flask and swirl gently but adequately a few minutes without shaking. Immediately add 10 drops of the ferric chloride solution and shake vigorously to react any hydrogen sulphide which may have come out of solution. Dilute each solution to the mark with water, mix well, and allow to stand for at least 20 min. The colour development should be conducted in the dark and if possible at 20 °C to 25 °C by means of the constant temperature bath. Read the maximum absorbance at the peak or near 670 nm, using water as the reference. Subtract the absorbance of the reaction blank (as the correction) from the calibration standards and the test specimens. Plot the corrected absorbance of the calibration standards against µg of sulphur present and draw the best straight line passing through zero. (The slope should be about 0.005 to 0.01 absorbance units per µg of sulphur per 10 nm of path length). Read the amount of reducible sulphur, in micrograms, in each specimen directly from the chart based on its net absorbance.

#### 10.2.5 Calculation

##### 10.2.5.1 Percentage reducible sulphur

$$= \frac{(\mu\text{g reducible sulphur from chart}) \times 0.0001}{\text{Mass of specimen in grams}}$$

### 10.3 Semi-Quantitative Method

#### 10.3.1 Apparatus

##### 10.3.1.1 Reaction apparatus

Consisting of a 100 ml flask carrying a short, water-cooled condenser as shown in [Fig. 2](#). A flanged head containing a disc of filter paper impregnated with lead acetate is placed over the condenser. The condenser prevents water vapour from condensing on the test paper which would cause an uneven development of the spots.

**10.3.1.2 Pipettes** — 1 ml graduated in 0.01 ml divisions and 10 ml graduated in 0.1 ml.

**10.3.1.3 Water bath** — At 100 °C, or steam bath

#### 10.3.2 Reagents

**10.3.2.1 Aluminium foil** — not over 0.25 mm thick, sulphur free

##### 10.3.2.2 Standard sodium thiosulphate solution

Dissolve 0.097 0 g of fresh, clean crystals of sodium Sodium thiosulphate pentahydrate ( $\text{Na}_2\text{S}_2\text{O}_3 \cdot 5\text{H}_2\text{O}$ ) in a little water in a 100 ml volumetric flask, dilute to mark and mix thoroughly. Dilute 10 ml of this solution to 1 litre and mix thoroughly. One ml is equivalent to 0.002 5 mg of sulphur.

**10.3.2.3 Lead acetate solution** — 20 percent

##### 10.3.2.4 Test paper

Rapid filtering grade of filter paper untouched with bare fingers and freshly impregnated with the lead acetate solution, dried and cut into 25 mm diameter discs stored in an air-tight container.

**10.3.2.5 Phosphoric acid** — 85 percent, sulphur free

#### 10.3.3 Test Specimen

Cut pieces of paper about 6 mm square from representative sample sheets and weigh the equivalent of  $0.25 \pm 0.005$  g of moisture free paper. Determine the average moisture content of the paper if it is not known to be within 1 percent. For papers which are low in sulphur, increase the weight of specimen preferably to 0.5, 0.75 or to a maximum of one gram. The sample for test and the test pieces shall be handled only with clean forceps.

#### 10.3.4 Procedure

Transfer the weighed test piece to the flask by means of forceps. Add a few millilitres of water and macerate the paper by a clean glass stirring rod until it is thoroughly soaked and at least partially disintegrated. Wash down the glass rod with a few millilitres of water until the total volume in the flask is about 20 ml. Add 2 g of aluminium foil cut into small pieces. Fit the funnel and the condenser to the flask. Insert in the neck of the condenser a loose wad of surgical cotton. Attach the head containing the disc of lead acetate paper, moistened with a minimum amount of water over the condenser. Through the dropping funnel add 10 ml of the phosphoric acid and close the cock. Provide arrangements for the introduction of stream of inert gas in the flask to remove the evolved hydrogen

sulphide gas. Heat the flask on the water bath for 45 min. Remove the apparatus and take out the lead acetate disc. Compare it with the set of discs stained with known amounts of sulphur prepared as described below and estimate the amount of sulphur evolved by the test piece. The set of stained discs shall be prepared using the same chemicals and procedure except that in place of the test piece measured amounts of the standard sodium thiosulphate solution, such as 0.1 ml, 0.2 ml, 0.4 ml,

0.6 ml, 0.8 ml and 1.0 ml respectively are added. This will give a range suitable for most papers. One millilitre of the solution contains the equivalent of 0.001 percent sulphur in a 0.25 g test piece.

### 10.3.5 Report

The amount of reducible sulphur shall be reported as a percentage by mass of the air-dry paper.

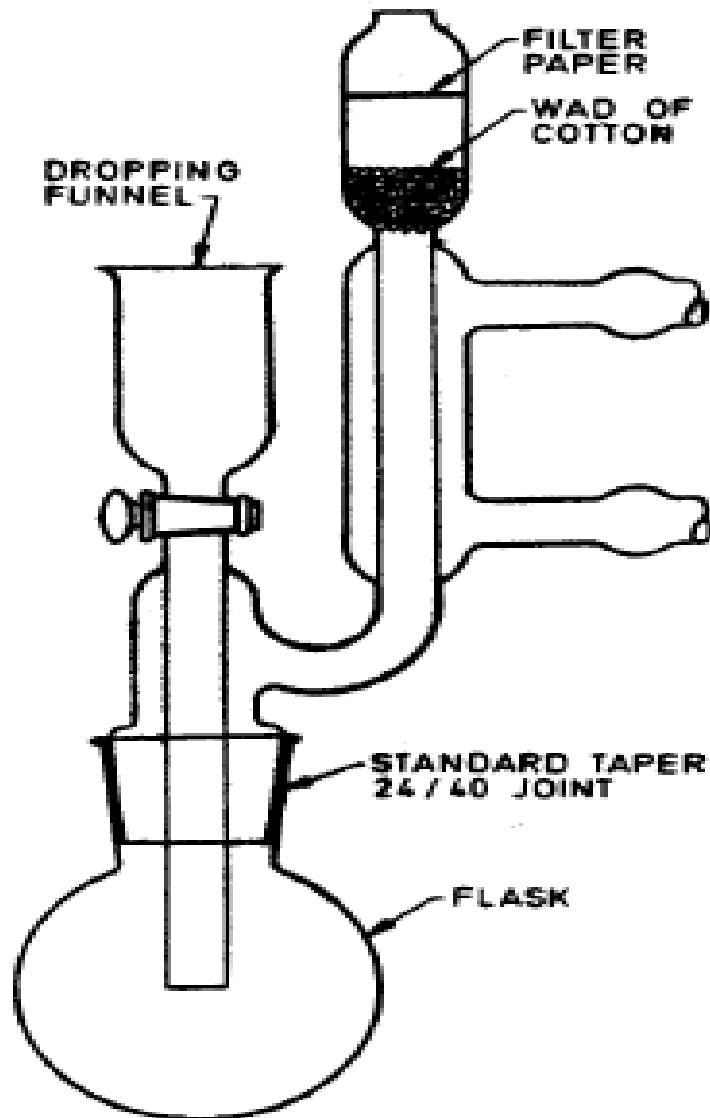

FIG. 2 REACTION APPARATUS

## 11 METHODS OF TEST FOR PAPER AND PULP BASED PACKAGING MATERIALS

<i>Sl No.</i>	<i>Methods of test for</i>	<i>IS No.</i>
(1)	(2)	(3)
i)	Abrasion loss	IS 4006 (Part 1)
ii)	Air permeance	IS 4006 (Part 1)
iii)	Alkali staining number	IS 1060 (Part 3)
iv)	Alkalinity	IS 1060 (Part 3)
v)	Alpha cellulose content	IS 1060 (Part 2)
vi)	Ash	IS 1060 (Part 4/Sec 2) and IS 1060 (Part 4/Sec 3)
vii)	Bending test	IS 1060 (Part 2)
viii)	Benzene of soluble matter, estimation of	IS 1060 (Part 2)
ix)	Bleeding resistance	IS 1060 (Part 2)
x)	Blocking resistance	IS 4006 (Part 1)
xi)	Breaking length	IS 1060 (Part 5/Sec 6)
xii)	Brightness	IS 1060 (Part 4/Sec 13)
xiii)	Bulk	IS 1060 (Part 5/Sec 3)
xiv)	Bursting strength	IS 1060 (Part 6/Sec 2)
xv)	Bursting strength, wet	IS 1060 (Part 2)
xvi)	Water-soluble Chlorides	IS 1060 (Part 4/Sec 8)
xvii)	Cobb test	IS 1060 (Part 5/Sec 4)
xviii)	Compression resistance, (ring crush)	IS 4006 (Part 1)
xix)	Copper number	IS 1060 (Part 3)
xx)	Cupping test	IS 1060 (Part 2)
xxi)	Matter soluble in ether	IS 1060 (Part 2)
xxii)	Exudation test	IS 1060 (Part 2)
xxiii)	Fastness to light	IS 1060 (Part 2)
xxiv)	Fatty and/or rosin acid extractable by ether	IS 1060 (Part 2)
xxv)	Fibre composition	IS 1060 (Part 1)
xxvi)	Flexural resistance and deflection	IS 4006 (Part 1)
xxvii)	Folding endurance	IS 1060 (Part 6/Sec 3)
xxviii)	Gloss	IS 1060 (Part 5/Sec 12)
xxix)	Grease resistance	IS 4006 (Part 1)
xxx)	Lead and lead compounds	IS 1060 (Part 2)
xxxi)	Moisture content	IS 1060 (Part 5/Sec 2)
xxxii)	Oil absorption	IS 1060 (Part 1)
xxxiii)	Opacity	IS/ISO 2471
xxxiv)	pH value	IS 1060 (Part 4/Sec 7)

<i>Sl No.</i>	<i>Methods of test for</i>	<i>IS No.</i>
(1)	(2)	(3)
xxxv)	Rigidity, stiffness and softness	IS 4006 (Part 1)
xxxvi)	Stiffness	IS 1060 (Part 3)
xxxvii)	Substance	IS 1060 (Part 5/Sec 5)
xxxviii)	Water-soluble Sulphates	IS 1060 (Part 4/Sec 9)
xxxix)	Surface pH	IS 1060 (Part 4/Sec 7)
xl)	Tearing resistance	IS 1060 (Part 6/Sec 1)
xli)	Tensile strength and stretch	IS 1060 (Part 5/Sec 6)
xl ii)	Tensile strength, wet	IS 1060 (Part 2)
xl iii)	Thickness	IS 1060 (Part 5/Sec 3)
xl iv)	Water absorbency	IS 1060 (Part 1)
xl v)	Water penetration	IS 1060 (Part 3) and IS 4006 (Part 1)
xl vi)	Water proofness	IS 4006 (Part 1)
xl vii)	Water vapour permeability	IS 1060 (Part 2)
xl viii)	Wax absorptiveness	IS 1060 (Part 3)
xl ix)	Wax pick number	IS 1060 (Part 3)

## ANNEX A

(Clause 2)

## LIST OF REFERRED STANDARDS

IS No.	Title	IS No.	Title
1060 (Part 1) : 2022	Methods of sampling and test for paper and allied products: Part 1 Test methods for general purpose ( <i>second revision</i> )	(Sec 4) : 2024/ ISO 535 : 2023	Determination of water absorptiveness — Cobb method ( <i>first revision</i> )
(Part 2) : 1960	Methods of sampling and test for paper and allied products: Part 2	(Sec 5) : 2021/ ISO 536 : 2019	Determination of grammage ( <i>first revision</i> )
(Part 3) : 1969	Methods of sampling and test for paper and allied products: Part 3	(Sec 6) : 2014/ ISO 1924-2 : 2008	Determination of tensile properties — Constant rate of elongation method (20 mm/min)
(Part 4)	Methods of test for paper, board and pulp,	(Sec 12) : 2021/ ISO 8254-1 : 2009	Measurement of specular gloss — 75 degree gloss with a converging beam, TAPPI method ( <i>first revision</i> )
(Sec 2) : 2018/ ISO 1762 : 2015	Determination of residue (ash) on ignition at 525 °C	(Part 6)	Methods of test for paper,
(Sec 3) : 2018/ ISO 2144 : 2015	Determination of residue (ash) on ignition at 900 °C	(Sec 1) : 2014/ ISO 1947 : 2012	Determination of tearing resistance — Elmendorf method
(Sec 7) : 2024 /ISO 6588-2 : 2021	Determination of pH of aqueous extracts — Hot extraction method ( <i>first revision</i> )	(Sec 2) : 2024/ ISO 2758 : 2014	Determination of bursting strength of paper ( <i>first revision</i> )
(Sec 8) : 2024/ ISO 9197 : 2016	Determination of water-soluble chlorides ( <i>first revision</i> )	(Sec 3) : 2015/ ISO 5626 : 1993	Determination of folding endurance of paper
(Sec 9) : 2024/ ISO 9198 : 2016	Determination of water-soluble sulfates ( <i>first revision</i> )	IS/ISO 2471 : 2008	Paper and Board — Determination of Opacity (Paper backing) — Diffuse reflectance method
(Sec 13) : 2020/ ISO 2470-1 : 2016	Measurement of diffuse blue reflectance factor — Indoor daylight conditions (ISO brightness) ( <i>first revision</i> )	IS 4006 (Part 1) : 1985	Methods of test for paper and pulp based packaging materials: Part 1 Flexural resistance and deflection, waterproofness, water penetration, grease resistance, abrasion loss, blocking resistance, compression resistance, rigidity, stiffness and softness; and air permeance ( <i>second revision</i> )
(Part 5)	Methods of test for paper and board,	IS 4261 : 2001	Glossary of terms relating to paper and pulp based packaging materials ( <i>first revision</i> )
(Sec 2) : 2021/ ISO 287 : 2017	Determination of moisture content of a lot — Oven-drying method ( <i>first revision</i> )		
(Sec 3) : 2014/ ISO 534 : 2011	Determination of thickness, density and specific volume		

To access Indian Standards click on the link below:

[https://www.services.bis.gov.in/php/BIS\\_2.0/bisconnect/knowyourstandards/Indian\\_standards/isdetails/](https://www.services.bis.gov.in/php/BIS_2.0/bisconnect/knowyourstandards/Indian_standards/isdetails/)

## ANNEX B

*(Foreword)*

## COMMITTEE COMPOSITION

Paper Based Packaging Materials Sectional Committee, CHD 16

<i>Organization</i>	<i>Representative(s)</i>
Indian Institute of Packaging, Mumbai	DR TANWEER ALAM ( <b><i>Chairperson</i></b> )
B & A Packaging(I) Ltd Kolkata	SHRI AMAL KUMAR MOHANTY SHRI TAPAN KR. CHAND ( <i>Alternate</i> )
Century Pulp & Paper Limited	SHRI SANJAY KUMAR YADAV SHRI SUNESH YADAV ( <i>Alternate</i> )
CPPRI, Saharanpur	DR M. K. GUPTA DR SANJAY TYAGI ( <i>Alternate</i> )
Dr Reddy laboratories	SHRI AVINASH TALWAR SHRI VINAY KR SINGH ( <i>Alternate</i> )
Federation of Corrugated Box Manufacturers of India, Mumbai	SHRI SATISH TYAGI SHRI K. P. SINGH ( <i>Alternate</i> )
Federation of paper convertors of India	SHRI MUKESH GUPTA SHRI SUSHIL KUMAR SINGH ( <i>Alternate</i> )
Hersheys India Pvt Ltd	MS DEEPA MANDAR NAIK
Indian Agro & Recycled Paper Mills Association, New Delhi	DR B. P. THAPLIYAL DR ANIL NAITHANI ( <i>Alternate</i> )
Indian Institute of Packaging	SHRI MADHAB CHAKRABORTY
Indian Institute of Technology, Roorkee	DR DHARM DUTT DR KIRTIRAJ K. GAIKWAD ( <i>Alternate I</i> ) DR VIBHOR KUMAR RASTOGI ( <i>Alternate II</i> )
Indian Paper Manufacturers Association, New Delhi	SHRI BISWARANJAN DASH SHRI ROHIT PANDIT ( <i>Alternate</i> )
ITC, Bhadrachalam	SHRI CHIDAMBARA VINAYAGAM SHRI P. N. SRIDHARR ( <i>Alternate</i> )
ITC Life Sciences, Bangalore	SHRI AJITH KUMAR DR KAMAL ( <i>Alternate</i> )
J K Paper	SHRI UMAKANT PATIL SHRI AAYUSH RAJ SRIVASTAVA ( <i>Alternate</i> )
Nestle India Ltd	SHRI BARUN BANERJEE SHRI DEEPAK SINGH ( <i>Alternate</i> )
Package Design Research and Test Lab, Moradabad	SHRI L.M. GUPTA SHRI MAYANK GUPTA ( <i>Alternate</i> )
Parksons Packaging	SHRI SRIKANTH RAMAMURTHY SHRI PAWAN KUMAR SINGH ( <i>Alternate</i> )

**IS 4006 (Part 2) : 2024**

<i>Organization</i>	<i>Representative(s)</i>
Prem Industries	SHRI ALOK GOEL SHRI H. P. SINGH ( <i>Alternate</i> )
Safepack Industries Limited	SHRI RAJENDRA TAPADIA SHRI ANAND TAPADI ( <i>Alternate</i> )
Siegwerk	SHRI JATIN THAKKAR PRIYANKA BAWEJA ( <i>Alternate</i> )
Stora Enso	SHRI SANJEEV KHANDELWAL
Tetra Pak India Pvt Ltd	SHRI SHARAD SHARMA SHRI JAIDEEP GOKHALE ( <i>Alternate</i> )
Uflex Limited	SHRI ASHVANI SHARMA SHRI RAKESH SHARMA ( <i>Alternate</i> )
BIS Directorate General	SHRI AJAY KUMAR LAL, SCIENTIST 'F'/SENIOR DIRECTOR AND HEAD (CHEMICAL) [REPRESENTING DIRECTOR GENERAL ( <i>Ex-officio</i> )]

*Member Secretary*  
SHRISHTI DIXIT  
SCIENTIST D/JOINT DIRECTOR  
(CHEMICAL), BIS





## Bureau of Indian Standards

BIS is a statutory institution established under the *Bureau of Indian Standards Act, 2016* to promote harmonious development of the activities of standardization, marking and quality certification of goods and attending to connected matters in the country.

### Copyright

BIS has the copyright of all its publications. No part of these publications may be reproduced in any form without the prior permission in writing of BIS. This does not preclude the free use, in the course of implementing the standard, of necessary details, such as symbols and sizes, type or grade designations. Enquiries relating to copyright be addressed to the Head (Publication & Sales), BIS.

### Review of Indian Standards

Amendments are issued to standards as the need arises on the basis of comments. Standards are also reviewed periodically; a standard along with amendments is reaffirmed when such review indicates that no changes are needed; if the review indicates that changes are needed, it is taken up for revision. Users of Indian Standards should ascertain that they are in possession of the latest amendments or edition by referring to the website-[www.bis.gov.in](http://www.bis.gov.in) or [www.standardsbis.in](http://www.standardsbis.in).

This Indian Standard has been developed from Doc No.: CHD 16 (20531).

### Amendments Issued Since Publication

Amend No.	Date of Issue	Text Affected

## BUREAU OF INDIAN STANDARDS

### Headquarters:

Manak Bhavan, 9 Bahadur Shah Zafar Marg, New Delhi 110002

Telephones: 2323 0131, 2323 3375, 2323 9402

Website: [www.bis.gov.in](http://www.bis.gov.in)

### Regional Offices:

Central : 601/A, Konnectus Tower -1, 6<sup>th</sup> Floor,  
DMRC Building, Bhavbhuti Marg, New  
Delhi 110002

Telephones

{ 2323 7617

Eastern : 8<sup>th</sup> Floor, Plot No 7/7 & 7/8, CP Block, Sector V,  
Salt Lake, Kolkata, West Bengal 700091

{ 2367 0012  
{ 2320 9474

Northern : Plot No. 4-A, Sector 27-B, Madhya Marg,  
Chandigarh 160019

{ 265 9930

Southern : C.I.T. Campus, IV Cross Road, Taramani, Chennai 600113

{ 2254 1442  
{ 2254 1216

Western : 5<sup>th</sup> Floor/MTNL CETTM, Technology Street, Hiranandani Gardens, Powai  
Mumbai 400076

{ 25700030  
{ 25702715

**Branches :** AHMEDABAD, BENGALURU, BHOPAL, BHUBANESHWAR, CHANDIGARH, CHENNAI, COIMBATORE, DEHRADUN, DELHI, FARIDABAD, GHAZIABAD, GUWAHATI, HARYANA (CHANDIGARH), HUBLI, HYDERABAD, JAIPUR, JAMMU, JAMSHEDPUR, KOCHI, KOLKATA, LUCKNOW, MADURAI, MUMBAI, NAGPUR, NOIDA, PARWANOO, PATNA, PUNE, RAIPUR, RAJKOT, SURAT, VIJAYAWADA.