प्रयोगशाला के लिए प्लास्टिक का सामान —
बीकर
(पहला पुनरीक्षण)

Plastics Laboratory Ware — Beakers
(First Revision)

ICS 17.060

© BIS 2024

© ISO 1981



भारतीय मानक ब्यूरो

BUREAU OF INDIAN STANDARDS

मानक भवन, 9 बहादुर शाह ज़फर मार्ग, नई दिल्ली - 110002

MANAK BHAVAN, 9 BAHADUR SHAH ZAFAR MARG

NEW DELHI - 110002

www.bis.gov.in www.standardsbis.in

August 2024

Price Group 5

NATIONAL FOREWORD

The Indian Standard (First Revision) which is identical to ISO 7056 : 1981 'Plastics laboratory ware — Beakers' issued by the International Organization for Standardization (ISO) was adopted by the Bureau of Indian Standards on the recommendation of the Glass, Glassware and Laboratoryware Sectional Committee and approval of the Chemical Division Council.

This standard prescribes requirements and methods of sampling and test for plastics graduated and ungraduated beakers for laboratory use. It is applicable to beakers having a tapered or a non-tapered form. The non-tapered form may, however, have a slight taper to facilitate mould release during manufacture.

The standard was first published in 1982. The first revision of the standard has been undertaken to align it with the ISO 7056 : 1981.

The text of ISO standard has been approved as suitable for publication as an Indian Standard without deviations. Certain conventions are, however, not identical to those used in Indian Standards. Attention is particularly drawn to the following:

- a) Wherever the words 'International Standard' appears referring to this standard, they should be read as 'Indian Standard'; and
- b) Comma (,) has been used as a decimal marker, while in Indian Standards, the current practice is to use a point (.) as the decimal marker.

In this adopted standard, reference appears to certain International Standards for which Indian Standards also exist. The corresponding Indian Standards, which is to be substituted in its place, is listed below along with its degree of equivalence for edition indicated:

<i>International Standard</i>	<i>Corresponding Indian Standard</i>	<i>Degree of Equivalence</i>
IEC 60335-1 : 2020 Household and similar electrical appliances — Safety — Part 1: General requirements	IS 302 (Part 1) : 2008/Safety of household and similar electrical appliances: Part 1 general requirements (<i>sixth revision</i>)	Modified/Technically Equivalent

This standard also makes a reference to the BIS Certification Marking of the product, details of which is given in [National Annex A](#).

For the purpose of deciding whether a particular requirement of this standard is complied with, the final value, observed or calculated expressing the result of a test or analysis, shall be rounded off in accordance with IS 2 : 2022 'Rules for rounding off numerical values (*second revision*)'. The number of significant places retained in the rounded off value should be the same as that of the specified value in this standard.

Indian Standard
PLASTICS LABORATORY WARE — BEAKERS
(*First Revision*)

1 Scope and field of application

This International Standard specifies requirements for a series of squat-form plastics beakers for laboratory use. It is applicable to beakers having a tapered or a non-tapered form. The non-tapered form may, however, have a slight taper to facilitate mould release during manufacture.

2 Reference

IEC Publication 335-1, *Safety of household and similar electrical appliances/Part 1 : General requirements.*

3 Sizes

The beakers covered by this International Standard have the following nominal capacities :

25 — 50 — 100 — 250 — 500 — 1 000 — 2 000 and 5 000 ml.

4 Graduation and figuring

Provided that the beaker is not opaque, it shall be graduated and figured on the outside as follows.

4.1 General

The graduation lines, figuring and inscriptions shall be clearly and durably marked.

4.2 Graduation lines

The graduation lines shall be of uniform thickness and shall lie in a plane perpendicular to the axis of the beaker. Each beaker shall bear figured graduation lines at intervals depending on the nominal capacity of the beaker, as defined in the table 1.

Table 1

Nominal capacity, ml	25	50	100	250	500	1 000	2 000	5 000
Figured intervals, ml	5	10	20	50	100	200	400	1 000

The highest graduation line shall indicate the nominal capacity of the beaker (see clause 5). The lowest graduation line shall indicate 20 % of the nominal capacity. Shorter, non-figured, intermediate graduation lines shall indicate intervals of 1, 2 or 5 ml, or decimal multiples thereof.

The figured graduated lines shall extend at least one-fifteenth of the way round the mean circumference of the beaker, but in any case shall be not less than 8 mm long.

The ends of the figured graduation lines shall lie on a line coplanar with the axis of the beaker; this line may be marked.

4.3 Figuring

The position of the figuring shall be such as to enable the value corresponding to each graduation line to be readily identified.

The figures indicating the nominal capacity of the beaker shall be adjacent to the top graduation line, shall be more prominent than the other figures, and shall be followed by the inscription "ml".

4.4 Tolerances

The errors in graduation shall not exceed $\pm 10\%$ of the indicated values.

5 Capacity

The brimful capacity of a beaker shall be not less than 1,3 times the nominal capacity of the beaker for sizes up to 500 ml, and not less than 1,2 times the nominal capacity for larger sizes.

6 Material

6.1 General

Beakers shall be rigidly constructed of generally non-brittle plastics material of suitable chemical and physical properties and shall be as free as possible from moulding defects and stress.

6.2 Resistance to extraction of ionic material by water at 60 °C

When tested by the method specified in annex A, the beaker shall give an aqueous extract free of suspended matter, and the difference between its conductivity and that of the original water used for the extraction shall not exceed the values given in table 2.

NOTE — The conductivity of water containing approximately 1 mg/l of sodium chloride is 200 $\mu\text{S}/\text{m}$.

Table 2

Nominal capacity ml	Difference in conductivity $\mu\text{S}/\text{m}$
25	1 000
50	800
100	700
250	500
500	400
1 000	300
2 000	250
5 000	150

7 Details of construction

7.1 Base

The base shall be such that the beaker stands vertically on a plane, horizontal surface without any tendency to spin or rock. The inside surface of the base shall be flat and free from moulding residues.

7.2 Brim

The diameter of the brim shall be not less than 10 % greater than the average external diameter of the body. The edge of the brim shall be finished in a plane parallel to that of the base. The inside surface of the beaker shall have a smooth contour.

7.3 Spout

The spout shall be so shaped that, when the beaker is filled to its nominal capacity with water, the water may be poured in a regular stream clear of the side of the beaker. The spout shall be at 90° to the radius drawn from the midpoint of the graduation lines and shall be on the left-hand side when the graduation lines face the user. The spout shall not extend above the plane of the brim of the beaker.

7.4 Shape

The ratio of overall height to maximum body diameter shall lie between 1,0 and 1,4.

If the sides of the beaker are not parallel, the body shall form a right frustum of a cone, the apex angle of which shall lie below the base of the beaker. This angle (defined as the angle included between the sides) may be the minimum required to en-

sure mould release in the manufacture of nominally non-tapered beakers, and shall not exceed 10° in the case of tapered beakers.

7.5 Radius at base

The internal radius at the junction between the base and the side of the beaker shall be not less than 3 mm.

7.6 Wall thickness

The wall thickness and brim design shall be such that, when the beaker is tested by the method specified in annex B, the outside diameter of the brim shall not decrease by more than 10 %.

The wall thickness shall be uniform, and the base thickness shall be not less than the wall thickness.

Substantial local irregularities shall be avoided.

7.7 Dimensions

Recommended nominal dimensions are given in table 3.

Table 3

Nominal capacity ml	Overall height, h mm	Average outside body diameter mm	Wall thickness mm min.
25	40	35	1,5
50	45	45	1,5
100	70	50	1,5
250	80	75	2
500	115	90	2
1 000	130	110	2
2 000	175	140	2
5 000	220	195	2,5

7.8 Surface finish

The inside and outside surfaces shall have a smooth contour.

8 Inscriptions

The following inscriptions shall be durably and legibly marked on all beakers :

- the words "approximate volumes", or a suitable abbreviation (on graduated beakers);
- the maker's and/or vendor's name or readily identifiable mark;
- the name of the material from which the beaker is made, for example "polypropylene" or the symbol "PP"¹⁾,

1) See ISO 1043, *Plastics — Symbols*.

and the manufacturer's recommended safe maximum temperature for short-term use (several hours) in contact with materials that do not attack the plastic; for example, for polypropylene : PP 135 °C max.

NOTE — The temperature in the example is merely intended to indicate an inscription and does not represent any particular grade of plastics material.

d) the pictogram shown in figure 1, or the words "no flame" (the former is preferred);

NOTE — The pictogram indicates that the beaker is not suitable for heating by flame or other heat sources (for example, on a hot plate) that raise the surface temperature above the manufacturer's recommended safe temperature for short-term use.

e) the number of the International Standard, or corresponding national standard.

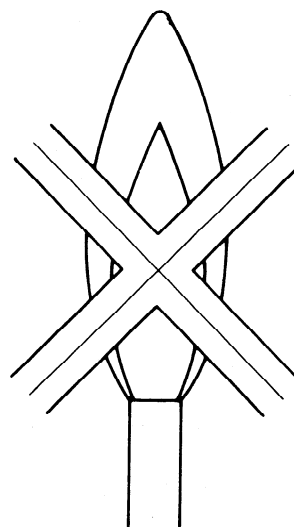

Figure 1 — Pictogram to be inscribed on the beaker

Annex A

Verification of resistance to extraction of ionic material by water at 60 °C

(Forms part of the Standard.)

A.1 Apparatus and materials

A.1.1 Watch glasses, made of borosilicate glass, and of sizes appropriate to the beakers under test.

A.1.2 Water bath, maintained at 60 ± 2 °C.

A.1.3 Conductivity meter, suitable for measurement of the electrical conductivity of water.

A.1.4 De-ionized water, having a conductivity of less than 200 $\mu\text{S}/\text{m}$.

The conductivity at 20 °C shall be determined before use.

A.1.5 Detergent solution.

A.2 Procedure

Thoroughly clean each beaker with hot water and the detergent solution (A.1.5), then rinse well with hot water followed by cold water and finally with liberal quantities of the de-ionized water (A.1.4).

Fill each beaker to its nominal capacity with the de-ionized water (A.1.4) and place in the water bath (A.1.2) maintained at 60 ± 2 °C to the depth of the water level in the beaker. Cover each beaker with a clean watch glass (A.1.1) and allow to stand for 3 h.

Remove each beaker from the water bath and allow the contents to cool to 20 °C. Measure the electrical conductivity of the water in each beaker by means of the conductivity meter (A.1.3), and record the difference in conductivity, in microsiemens per meter, of the water before and after the test.

Annex B

Flexibility test

(Forms part of the Standard.)

B.1 Apparatus

NOTE — The general arrangement of the apparatus is shown in figure 2.

B.1.1 Square wooden blocks, up to 15 in number, each 19 mm thick, from which a square of up to 110 mm side but not exceeding one-quarter of the original block, has been cut from one corner.

B.1.2 Test pin, complying with the requirements of IEC Publication 335-1.

B.1.3 Test pin guide, consisting of a stiff plate having a 13 mm hole, suitably mounted so that it is adjustable in distance (from 65 to 275 mm) from the inside corner of the blocks, and adjustable in height (from 25 to 220 mm).

B.1.4 Thermometer, reading from 0 to 100 °C and graduated at every 1 °C.

B.1.5 Calipers, for measurement of external diameters, opening up to 250 mm.

B.1.6 G-clamp.

B.2 Procedure

B.2.1 Stack a sufficient number of the wooden blocks (B.1.1) to bring the highest one just below the brim of the beaker to be tested. Adjust the blocks so that each touches the beaker at two points and clamp the stack to the working sur-

face. Adjust the brackets bearing the test pin guide (B.1.3) such that the test pin (B.1.2), when inserted through the hole, will touch the beaker at a height equal to three-quarters of the total height of the beaker. Further adjust the brackets bearing the guide such that the guide is perpendicular to the plane of the axis of the beaker and the inside corners of the blocks and is fixed 20 mm from the beaker.

B.2.2 Using the calipers, measure the outside diameter (d_1) of the brim of the beaker in the direction the force is to be applied by the test pin.

B.2.3 Fill the beaker to its nominal capacity with water at 60 ± 2 °C. Insert the test pin through the guide and apply a steady force of 30 N, as shown by the force indicator of the test pin, horizontally and towards the axis of the beaker.

After approximately 1 min, and while maintaining the force, again measure the outside diameter (d_2) as described in B.2.2. Remove the test pin. Check the temperature of the water; if it is different from 60 ± 2 °C, reject the readings and repeat the procedures in B.2.2 and B.2.3.

B.2.4 Rotate the beaker 90° and repeat the procedures in B.2.2 and B.2.3.

B.3 Express the result as the percentage change in diameter, as given by the formula

$$\left(1 - \frac{d_2}{d_1}\right) \times 100$$

Report the higher of the values obtained in the two determinations (i.e. the value obtained in B.2.3, or that obtained in B.2.4).

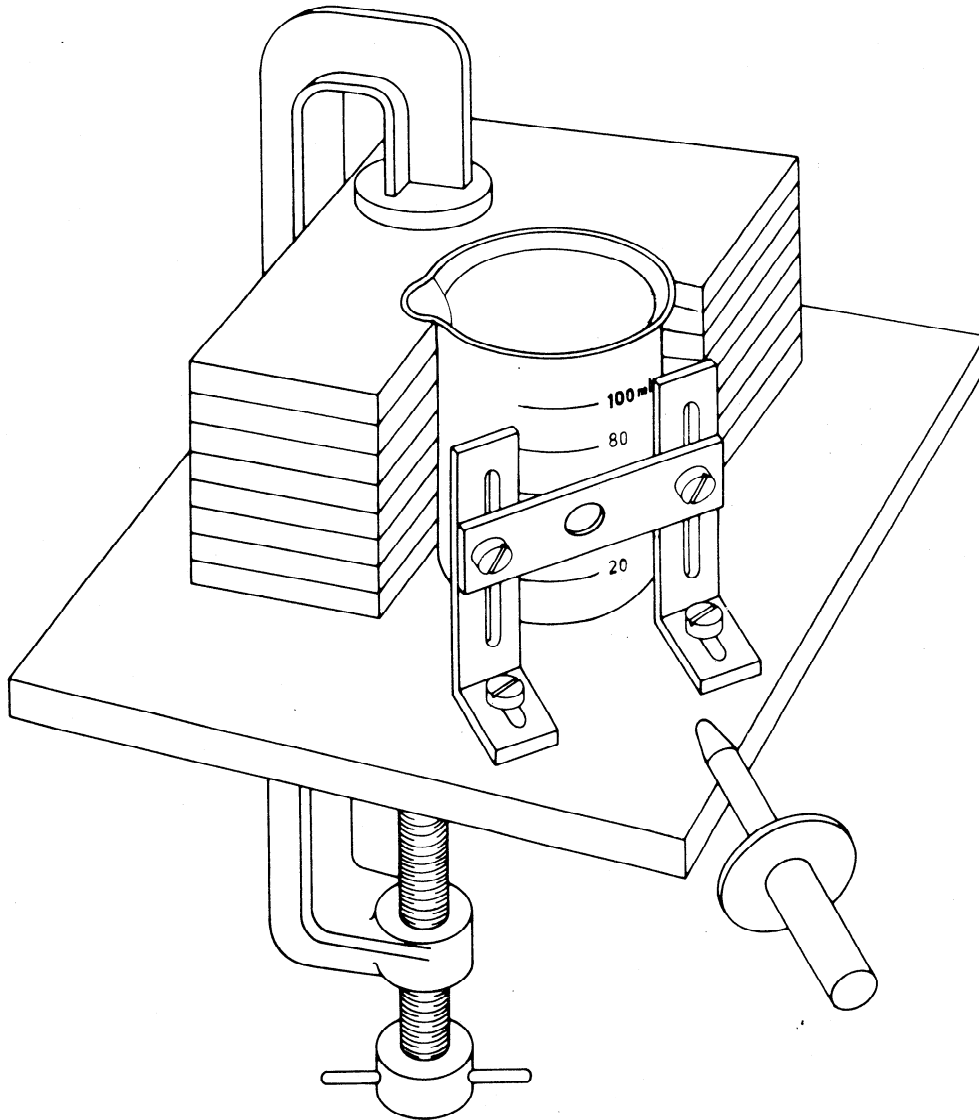

Figure 2 — Apparatus for flexibility test for plastics beakers

NATIONAL ANNEX A
(National Foreword)

A-1 BIS CERTIFICATION MARKING

The product(s) conforming to the requirements of this standard may be certified as per the conformity assessment schemes under the provisions of the *Act of Indian Standards Act 2016* and the Rules and Regulations framed thereunder, and the product(s) may be marked with the Standard Mark.

Bureau of Indian Standards

BIS is a statutory institution established under the *Bureau of Indian Standards Act, 2016* to promote harmonious development of the activities of standardization, marking and quality certification of goods and attending to connected matters in the country.

Copyright

BIS has the copyright of all its publications. No part of these publications may be reproduced in any form without the prior permission in writing of BIS. This does not preclude the free use, in the course of implementing the standard, of necessary details, such as symbols and sizes, type or grade designations. Enquiries relating to copyright be addressed to the Head (Publication & Sales), BIS.

Review of Indian Standards

Amendments are issued to standards as the need arises on the basis of comments. Standards are also reviewed periodically; a standard along with amendments is reaffirmed when such review indicates that no changes are needed; if the review indicates that changes are needed, it is taken up for revision. Users of Indian Standards should ascertain that they are in possession of the latest amendments or edition by referring to the website-www.bis.gov.in or www.standardsbis.in.

This Indian Standard has been developed from Doc No.: CHD 10 (21576).

Amendments Issued Since Publication

Amend No.	Date of Issue	Text Affected

BUREAU OF INDIAN STANDARDS

Headquarters:

Manak Bhavan, 9 Bahadur Shah Zafar Marg, New Delhi 110002

Telephones: 2323 0131, 2323 3375, 2323 9402

Website: www.bis.gov.in

Regional Offices:

Central : 601/A, Konnectus Tower -1, 6th Floor,
DMRC Building, Bhavbhuti Marg, New
Delhi 110002

Telephones

{ 2323 7617

Eastern : 8th Floor, Plot No 7/7 & 7/8, CP Block, Sector V,
Salt Lake, Kolkata, West Bengal 700091

{ 2367 0012
2320 9474

Northern : Plot No. 4-A, Sector 27-B, Madhya Marg,
Chandigarh 160019

{ 265 9930

Southern : C.I.T. Campus, IV Cross Road, Taramani, Chennai 600113

{ 2254 1442
2254 1216

Western : Manakalya, 5th Floor/MTNL CETTM, Technology Street, Hiranandani Gardens, Powai
Mumbai 400076

{ 25700030
25702715

Branches : AHMEDABAD, BENGALURU, BHOPAL, BHUBANESHWAR, CHANDIGARH, CHENNAI, COIMBATORE, DEHRADUN, DELHI, FARIDABAD, GHAZIABAD, GUWAHATI, HARYANA (CHANDIGARH), HUBLI, HYDERABAD, JAIPUR, JAMMU, JAMSHEDPUR, KOCHI, KOLKATA, LUCKNOW, MADURAI, MUMBAI, NAGPUR, NOIDA, PARWANOO, PATNA, PUNE, RAIPUR, RAJKOT, SURAT, VIJAYAWADA.