

बोरवेल/नलकूप के लिए असुघटियत  
पॉलीविनायल क्लोराइड (पीवीसी-यू) के  
चूड़ीदार कॉलम पाइप — विशिष्टि

Unplasticized Polyvinyl Chloride  
(PVC-U) Threaded Column Pipes for  
Borewells/Tubewells — Specification

ICS 23.040.20

© BIS 2023



भारतीय मानक ब्यूरो  
BUREAU OF INDIAN STANDARDS  
मानक भवन, 9 बहादुर शाह ज़फर मार्ग, नई दिल्ली - 110002  
MANAK BHAVAN, 9 BAHADUR SHAH ZAFAR MARG  
NEW DELHI - 110002  
[www.bis.gov.in](http://www.bis.gov.in) [www.standardsbis.in](http://www.standardsbis.in)

## FOREWORD

This Indian Standard was adopted by the Bureau of Indian Standards, after the draft finalized by the Plastic Piping System Sectional Committee had been approved by the Civil Engineering Division Council.

This standard has been formulated to cover requirements and test methods for unplasticized polyvinyl chloride (PVC-U) threaded column pipes for use with jet and submersible pumps in borewells/tubewells.

It is the responsibility of the purchaser or the supplier to make the appropriate selection of pipes taking into account their particular requirements and any relevant national guidelines or regulations. Relevant guidelines for installation practices should be followed.

The composition of the Committee responsible for the formulation of this standard is given in Annex D.

For the purpose of deciding whether a particular requirement of the standard is complied with, the final value observed or calculated, expressing the result of a test or analysis, shall be rounded off in accordance with IS 2 : 2022 'Rules for rounding off numerical values (*second revision*)'. The number of significant places retained in the rounded off value should be the same as that of the specified value in this standard.

*Indian Standard*

# UNPLASTICIZED POLYVINYL CHLORIDE (PVC-U) THREADED COLUMN PIPES FOR BOREWELLS/ TUBEWELLS — SPECIFICATION

**1 SCOPE**

**1.1** This standard covers the requirements of unplasticized polyvinyl chloride (PVC-U) threaded column pipes of the following types and sizes, for use with jet or submersible pumps in borewells/tubewells for water supply:

- a) Bell ended (socketed) type with external thread at spigot end and internal thread at bell (socket) end, of nominal sizes 25 mm, 32 mm and 40 mm; and
- b) Coupler joint type with external threads at both ends, connected with coupler, of nominal sizes 25 mm to 150 mm.

**1.2** These pipes are recommended for water temperatures ranging from 1 °C to 45 °C.

**2 REFERENCES**

The standards listed in Annex A contain provisions which, through reference in this standard, constitute provisions of this standard. At the time of publication, the editions indicated were valid. All standards are subject to revision, and parties to agreements based on this standard are encouraged to investigate the possibility of applying the most recent editions of these standards.

**3 TERMINOLOGY**

For the purpose of this standard, the following definitions shall apply:

**3.1 Column Pipes** — Pipes with external threads at both ends, or with external thread at one end and internal thread at the other end, for carrying out ground water with jet/submersible pump from borewell/tubewell.

**3.2 Column Pipe Couplers** — Cut piece of pipe with internal threads at both ends to assemble/join the column pipes.

**3.3 Bell End Column Pipes** — Column pipes with bell and spigot end, in which female (internal) thread is provided at bell end and male (external) thread at spigot end for connection of pipes.

**3.4 Nominal Size (DN)** — The numerical designation for the size of the pipe other than a pipe designated by thread size, which is a convenient round number approximately equal to the manufactured dimension, in mm.

**3.5 Nominal Outer Diameter ( $d_o$ )** — The specified outside diameter, in mm, assigned to a nominal size.

**3.6 Mean Outer Diameter ( $d_{em}$ )** — The quotient of the outer circumference of a pipe and 3.142 ( $\pi$ ) in any cross-section, rounded off to the next higher 0.1 mm.

**3.7 Minimum Mean Outer Diameter ( $d_{em, Min}$ )** — The minimum value for the mean outside diameter as specified for a given nominal size.

**3.8 Maximum Mean Outer Diameter ( $d_{em, Max}$ )** — The maximum value for the mean outside diameter as specified for a given nominal size.

**3.9 Outer Diameter at Any Point ( $d_e$ )** — The value of the measurement of the outer diameter of a pipe through its cross-section at any point of the pipe, rounded off to next higher 0.1 mm.

**3.10 Out-of-Roundness (Ovality)** — The difference between the measured maximum and the measured minimum outside diameter in the same cross-section of the pipe.

**3.11 Nominal Wall Thickness ( $e_{ne}$  and  $e_{nb}$ )** — A numerical designation of the wall thickness of a component which is a convenient round number, approximately equal to the manufacturing dimensions, in mm.

NOTE —  $e_{nb}$  and  $e_{ne}$  are nominal wall thickness of barrel (thin portion) and end side (thick portion), respectively.

**3.12 Wall Thickness at any Point ( $e_e$  and  $e_b$ )** — The value of the measurement of the wall thickness at any point around the circumference of the pipe, rounded off to the next higher 0.1 mm.

NOTE —  $e_b$  and  $e_e$  are wall thickness at any point of barrel (thin portion) and end side (thick portion), respectively.

**3.13 Mean Wall Thickness ( $e_{me}$  and  $e_{mb}$ )** — The arithmetical mean of at least four measurements

regularly spaced around the circumference and in the same cross-section of the pipe, including the measured minimum and the measured maximum values of the wall thickness in that cross-section, rounded off to the next higher 0.1 mm.

NOTE —  $e_{mb}$  and  $e_{me}$  are mean wall thickness of barrel (thin portion) and end side (thick portion), respectively.

**3.14 Tolerance** — The permitted variation of the specified value of a quantity, expressed as the difference between the permitted maximum and the permitted minimum value.

**3.15 Working Pressure (PN)** — The numerical designation of a pipe related to the mechanical characteristics of that pipe used for reference purposes. For plastic piping systems, it corresponds to the allowable operating pressure, in MPa, conveying water at 27 °C.

**3.16 Allowable Operating Pressure (PFA)** — The maximum hydrostatic pressure excluding surge which is allowed in continuous use with water within the temperature range concerned. It is calculated using the following equation:

$$PFA = f_T \times PN$$

where

$f_T$  = derating factor depending on water temperature; and  
 $PN$  = working pressure.

NOTE — In cases where a further derating (or uprating) factor depending on the application is required,

$$PFA = f_A \times f_T \times PN$$

where

$f_A$  = factor depending on the application.

**3.17 Hydrostatic Stress ( $\sigma$ )** — The stress induced in the wall of a pipe when a pressure is applied using water as a medium. The hydrostatic stress is related to the applied pressure,  $P$ , the wall thickness of thin portion at any point,  $e_b$ , and the mean outside diameter,  $d_{em}$ , of a pipe and calculated using the following approximation equation:

$$\sigma = \frac{P(d_{em} - e_b)}{2e_b}$$

where  $\sigma$  and  $P$  are in same units.

**3.18 Virgin Material** — Material in such form as granules or powder that has not been subjected to use or processing other than that required for its manufacture and to which no reprocessible or recyclable material(s) have been added.

**3.19 Own Rework Material** — Material prepared from rejected unused pipes, including trimmings from the production of pipes, that will be reprocessed in a manufacturer's plant by a process such as extrusion and for which the complete formulation is known.

## 4 COMPOSITION

**4.1** The material from which the pipe is produced shall consist substantially of unplasticized polyvinyl chloride to which may be added only those additives that are needed to facilitate production of sound and durable pipe of good surface finish and mechanical strength under conditions of use. None of these additives shall be used, separately or together, in quantities sufficient to constitute a toxic, organoleptic or microbial growth hazard or to materially impair the fabrication or welding properties of the pipe, or to impair the chemical, physical or mechanical properties (in particular long-term mechanical strength and impact strength) as defined in this standard. The additives to be used shall be selected from IS 10148 and shall be uniformly dispersed.

**4.1.1** The monomer content (VCM content) in the resin shall be within the limits specified in **4.4.1** of IS 10151, when tested as per Annex B of IS 10151.

**4.1.2** The composition shall be based on PVC resin having a K-value of 64 or greater, when tested in accordance with IS 4669.

**4.1.3** A test report or certificate of conformity may be obtained from the manufacturer for the VCM content (*see 4.1.1*) and K-value (*see 4.1.2*) of the resin being used, unless the same is tested in an independent laboratory. The frequency of this test report or certificate of conformity shall be once in every three months.

**4.2** The addition of not more than 5 percent of the manufacturer's own rework material conforming to this standard is permissible. No other rework material shall be used.

## 5 COLOUR

The pipe and coupler shall be of regular ivory white colour throughout. Slight colour deviation is permissible.

## 6 CLASSIFICATION

The pipes shall be classified by pressure ratings (working pressures) at 27 °C as per Table 1. The maximum permissible hydraulic head of different classes of column pipes shall be as given in Table 1.

The maximum safe working stress considered is 14 MPa at 27 °C.

**Table 1 Classification of Column Pipes**  
(Clause 6)

| SI No. | Class   | Working Pressure, (PN) | Maximum Permissible Hydraulic Head<br>m |
|--------|---------|------------------------|---|
| (1)    | (2)     | (3)                    | (4)                                     |
| i)     | Class 1 | 1.0                    | 100                                     |
| ii)    | Class 2 | 1.25                   | 125                                     |
| iii)   | Class 3 | 1.5                    | 150                                     |
| iv)    | Class 4 | 2.0                    | 200                                     |
| v)     | Class 5 | 2.5                    | 250                                     |
| vi)    | Class 6 | 3.5                    | 350                                     |
| vii)   | Class 7 | 4.0                    | 400                                     |

NOTE — 1 MPa = 10 kg/cm<sup>2</sup>.

## 7 DIMENSIONS

**7.1** The diameters and wall thicknesses of unthreaded column pipes with thick-end portion shall be as given in Table 2 and Table 3 read with Fig. 1A and threaded column pipe with thick/thin portion is shown in Fig. 1B. The dimensional details of unthreaded column pipe couplers shall be as given in Table 4 read with Fig. 1C. The (design indicated as c and d in Fig. 1C) and number of ribs shall be as agreed between the manufacturer and the purchaser so as to ensure proper gripping during installation. The square threads on column pipes and column pipe couplers shall be as shown in Fig. 1D and Fig. 1E, respectively read with Tables 5 and 6. However, the assembly/jointing design (sealing ring/groove) shown in these figures are typical. The dimensional details of bell-ended pipes shall be as given in Table 7 read with Fig. 2. Belling dimensions of pipe

shall be as per manufacturer's design or as per the mutual agreement between the manufacturer and the purchaser.

**7.2** Mean outer diameter and outer diameter at any point of unthreaded column pipes shall be measured according to IS 12235 (Part 1). The pipe diameter shall be measured at the thick end portion of the pipe.

**7.3** Wall thickness of unthreaded column pipes shall be measured in accordance with the method given in IS 12235 (Part 1).

**7.4** Nominal effective length of column pipe shall be minimum 3 000 mm. The pipes may be supplied in other lengths where so agreed upon between the manufacturer and the purchaser.

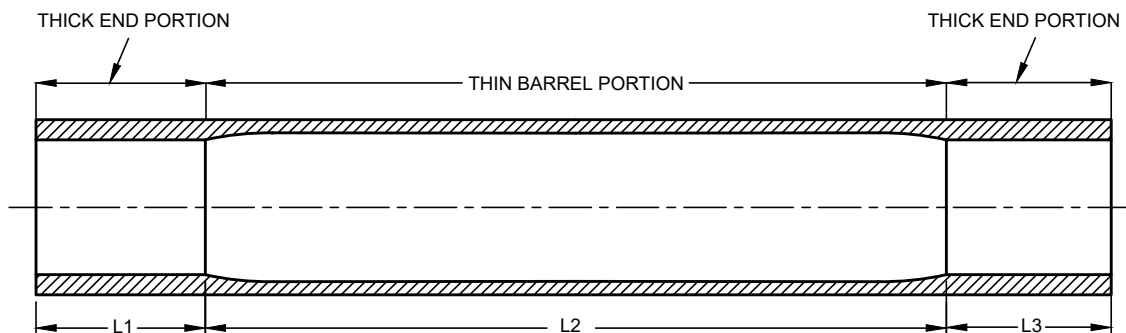

1A UNTHREADED PIPE

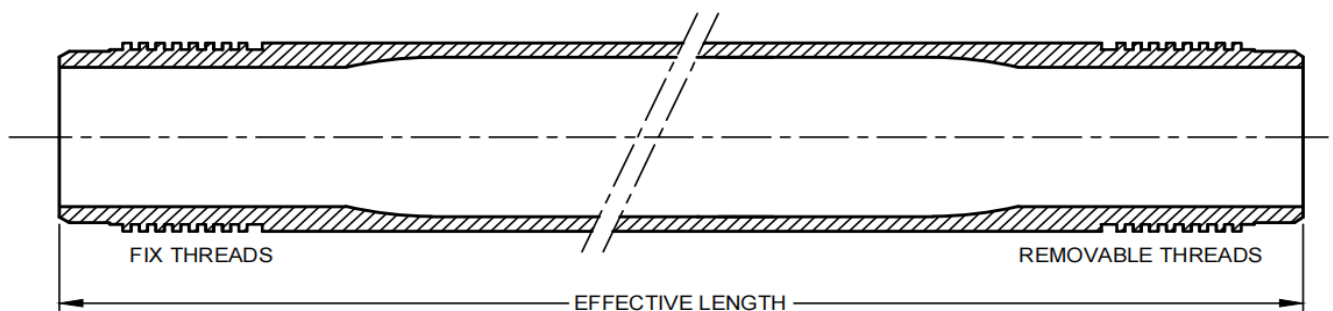

1B THREADED PIPE

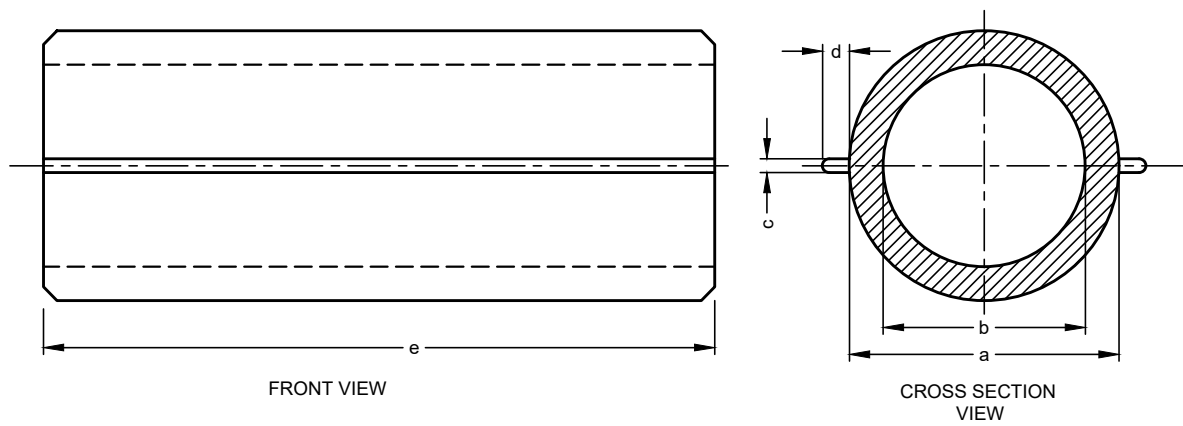

1C RIBBED COUPLER BEFORE THREADING

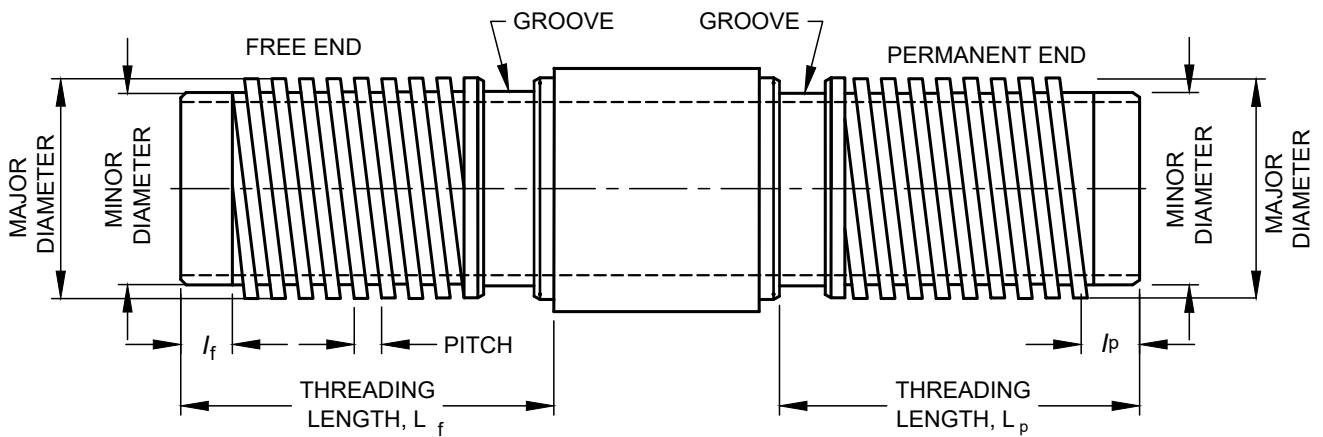

NOTE — The assembly/jointing design shown in figure is typical.

1D THREADS PROFILE OF COLUMN PIPE

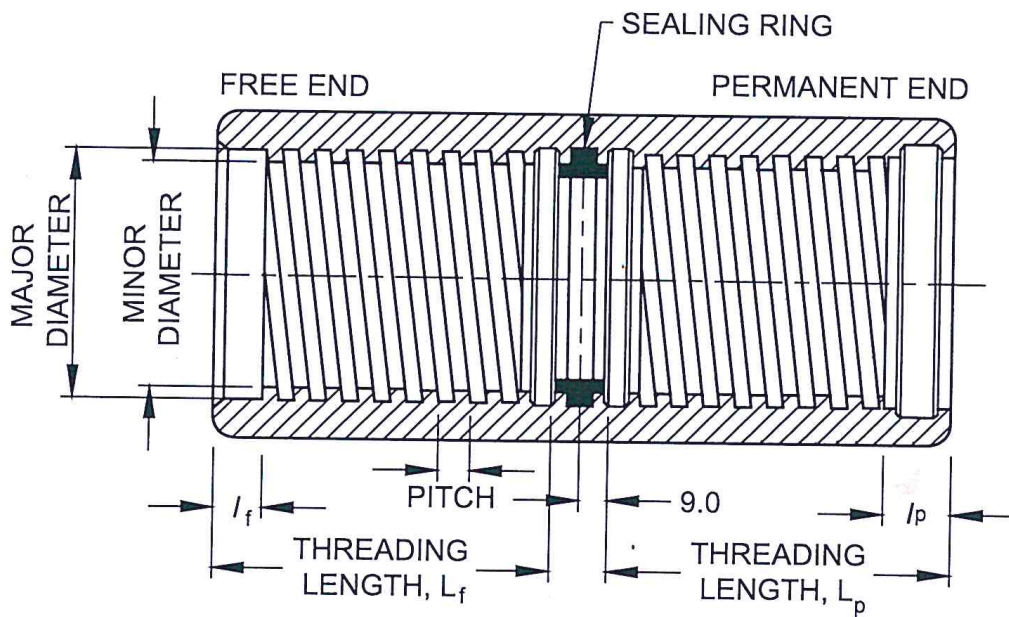

All dimensions in millimetres

NOTE — The assembly/jointing design shown in the figure is typical.

1E THREADS OF COLUMN PIPE COUPLER

FIG. 1 COUPLER JOINTED THREADED COLUMN PIPES

**Table 2 Outer Diameter of Unthreaded Column Pipes**

(Clause 7.1)

All dimensions in millimetres.

| SI No. | Nominal Size, $DN$ | Mean Outer Diameter of Pipe, $d_{em}$ |            | Outer Diameter at any Point, $d_e$ |            |
|--------|--------------------|---------------------------------------|------------|------------------------------------|------------|
|        |                    | <i>Min</i>                            | <i>Max</i> | <i>Min</i>                         | <i>Max</i> |
| (1)    | (2)                | (3)                                   | (4)        | (5)                                | (6)        |
| i)     | 25                 | 33.0                                  | 33.3       | 32.8                               | 33.5       |
| ii)    | 32                 | 42.0                                  | 42.3       | 41.8                               | 42.5       |
| iii)   | 40                 | 48.0                                  | 48.3       | 47.8                               | 48.5       |
| iv)    | 50                 | 60.0                                  | 60.3       | 59.8                               | 60.5       |
| v)     | 65                 | 75.0                                  | 75.3       | 74.8                               | 75.6       |
| vi)    | 80                 | 88.0                                  | 88.4       | 87.8                               | 88.6       |
| vii)   | 100                | 113.0                                 | 113.4      | 112.8                              | 113.6      |
| viii)  | 125                | 140.0                                 | 140.4      | 139.8                              | 140.6      |
| ix)    | 150                | 165.0                                 | 165.4      | 164.8                              | 165.6      |

## 8 THREADING OF COLUMN PIPES AND COUPLERS

### 8.1 Column Pipes

Pipes with external threads at both ends shall be used with couplers. Bell end pipes shall have external threads at one end and internal threads at the other end.

### 8.2 Column Couplers

Column couplers shall have internal threads at both ends.

**8.3** Pipes shall have basic thread dimensions as given in Table 5 read with Fig. 1D. Couplers shall have basic thread dimensions as given in Table 6 read with Fig. 1E.

**8.4** Sealing rings and elements made of elastomeric material such as EPDM, and of appropriate dimensions ensuring secure fit, shall be used to seal the joint. These sealing materials shall be of hardness class 60 IRHD as per IS 5382. The design of the profile of the sealing ring is left to the manufacturer as long as the pipe with sealing ring meets the requirements of the standard and ensures leak free installation.

**8.4.1** A test report or conformity certificate shall be obtained from the manufacturer of the sealing ring for conformity to IS 5382. The frequency of this test report or conformity certificate shall be once in three months.

**8.5** The design for the locking of permanent end pipe with coupler is left to the manufacturer as long as the pipe and coupler assembly meets the requirements of the standard and ensures leak free installation.

**8.5.1** The manufacture should declare regarding the use of adhesive/solvent if any. Such material, when used, shall not have any detrimental effect on the quality of water for its intended use.

## 9 TESTS

### 9.1 Visual Appearance

The internal and external surfaces of the pipe shall be smooth, clean and free from other defects. Slight shallow longitudinal grooves or irregularities in the wall thickness shall be permissible provided the pipe dimensions remain within permissible limits. The ends shall be clean, smoothly cut and reasonably square to the axis of the pipe.

### 9.2 Resistance to External Blows at 0 °C

When tested by the method described in IS 12235 (Part 9), the pipe shall have a true impact rate of not more than 10 percent. The total mass of the striker and height of free fall shall correspond to the values given in Table 8.

### 9.3 Flattening Test

Flatten the specimens of pipe of at least 50 mm length, taken from both end (thick) and barrel (thin) portion of the pipe and from the column pipe coupler, between parallel plates in a suitable press until the distance between the plates is 40 percent of the outside diameter of the pipe or the inner walls of the pipe touch, whichever occurs first. This test shall be carried out in accordance with the method given in IS 12235 (Part 19). The rate of the loading shall be uniform and such that the compression is completed within 2 min to 5 min. On removal of load, examine the specimen for evidence of splitting, cracking or breaking.

**Table 3 Wall Thickness of Different Classes of Unthreaded Column Pipes with Thick-Thin Portion**  
(Clause 7.1)

| SI No. | Nominal Size, <i>DN</i> | Class of Pipe | Both End (Thick) Portion |            | Barrel (Thin) Portion |            | Length of Thick Portion at Both Side ( <i>L1</i> and <i>L3</i> ),<br><i>Min</i> | Induced Stress, <i>Min</i> |
|--------|-------------------------|---------------|--------------------------|------------|-----------------------|------------|---|----------------------------|
|        |                         |               | <i>Min</i>               | <i>Max</i> | <i>Min</i>            | <i>Max</i> |   |                            |
| (1)    | mm<br>(2)               | mm<br>(3)     | mm<br>(4)                | mm<br>(5)  | mm<br>(6)             | mm<br>(7)  | mm<br>(8)   | MPa<br>(9)                 |
| i)     | 25                      | Class 1       | 2.9                      | 3.30       | 1.50                  | 1.80       | 150   | 12                         |
|        |                         | Class 2       | 3.3                      | 3.80       | 1.70                  | 2.00       | 150   | 12                         |
|        |                         | Class 3       | 3.8                      | 4.40       | 1.90                  | 2.20       | 150   | 13                         |
|        |                         | Class 4       | 4.6                      | 5.30       | 2.40                  | 2.80       | 150   | 13                         |
| ii)    | 32                      | Class 1       | 3.3                      | 3.80       | 1.50                  | 1.80       | 180   | 14                         |
|        |                         | Class 2       | 3.7                      | 4.30       | 1.80                  | 2.10       | 180   | 14                         |
|        |                         | Class 3       | 4.3                      | 5.00       | 2.20                  | 2.50       | 180   | 14                         |
|        |                         | Class 4       | 5.40                     | 6.20       | 2.80                  | 3.20       | 180   | 14                         |
|        |                         | Class 5       | 6.50                     | 7.50       | 3.50                  | 4.00       | 180   | 14                         |
|        |                         | Class 6       | 8.30                     | 9.60       | 4.70                  | 5.40       | 180   | 14                         |
|        |                         | Class 7       | 8.50                     | 9.80       | 5.80                  | 6.70       | 200   | 14                         |
| iii)   | 40                      | Class 1       | 3.50                     | 4.00       | 1.70                  | 2.00       | 180   | 14                         |
|        |                         | Class 2       | 4.10                     | 4.70       | 2.10                  | 2.40       | 180   | 14                         |
|        |                         | Class 3       | 4.90                     | 5.70       | 2.50                  | 2.90       | 180   | 14                         |
|        |                         | Class 4       | 5.90                     | 6.80       | 3.20                  | 3.70       | 180   | 14                         |
|        |                         | Class 5       | 7.20                     | 8.30       | 4.00                  | 4.60       | 180   | 14                         |
|        |                         | Class 6       | 9.30                     | 10.70      | 5.40                  | 6.20       | 180   | 14                         |
|        |                         | Class 7       | 9.60                     | 11.00      | 6.50                  | 7.50       | 200   | 14                         |
| iv)    | 50                      | Class 1       | 4.20                     | 4.90       | 2.10                  | 2.40       | 180   | 14                         |
|        |                         | Class 2       | 4.90                     | 5.60       | 2.60                  | 3.00       | 180   | 14                         |
|        |                         | Class 3       | 5.90                     | 6.80       | 3.10                  | 3.60       | 180   | 14                         |
|        |                         | Class 4       | 7.20                     | 8.30       | 4.00                  | 4.60       | 200   | 14                         |
|        |                         | Class 5       | 8.80                     | 10.10      | 5.00                  | 5.80       | 200   | 14                         |
|        |                         | Class 6       | 11.10                    | 12.80      | 6.70                  | 7.70       | 200   | 14                         |
|        |                         | Class 7       | 11.30                    | 13.00      | 8.20                  | 9.20       | 200   | 14                         |
| v)     | 65                      | Class 1       | 5.00                     | 5.80       | 2.60                  | 3.00       | 180   | 14                         |
|        |                         | Class 2       | 6.00                     | 6.90       | 3.30                  | 3.80       | 180   | 14                         |
|        |                         | Class 3       | 7.00                     | 8.10       | 3.90                  | 4.50       | 180   | 14                         |
|        |                         | Class 4       | 8.60                     | 9.90       | 5.00                  | 5.80       | 200   | 14                         |
|        |                         | Class 5       | 10.40                    | 12.00      | 6.20                  | 7.10       | 200   | 14                         |
|        |                         | Class 6       | 13.50                    | 15.50      | 8.40                  | 9.70       | 200   | 14                         |
| vi)    | 80                      | Class 1       | 5.60                     | 6.40       | 3.10                  | 3.60       | 180   | 14                         |
|        |                         | Class 2       | 6.50                     | 7.50       | 3.80                  | 4.40       | 180   | 14                         |
|        |                         | Class 3       | 7.90                     | 9.10       | 4.50                  | 5.20       | 180   | 14                         |
|        |                         | Class 4       | 9.70                     | 11.20      | 5.90                  | 6.80       | 200   | 14                         |
|        |                         | Class 5       | 11.60                    | 13.30      | 7.30                  | 8.40       | 200   | 14                         |
|        |                         | Class 6       | 15.20                    | 17.50      | 9.80                  | 11.30      | 200   | 14                         |
| vii)   | 100                     | Class 1       | 6.80                     | 7.80       | 3.90                  | 4.50       | 180   | 14                         |
|        |                         | Class 2       | 8.20                     | 9.40       | 4.90                  | 5.70       | 180   | 14                         |
|        |                         | Class 3       | 9.60                     | 11.00      | 5.80                  | 6.70       | 180   | 14                         |
|        |                         | Class 4       | 11.90                    | 13.70      | 7.60                  | 8.60       | 200   | 14                         |
|        |                         | Class 5       | 14.30                    | 16.50      | 9.30                  | 10.70      | 200   | 14                         |
|        |                         | Class 6       | 19.00                    | 21.90      | 12.60                 | 14.50      | 200   | 14                         |
| viii)  | 125                     | Class 1       | 8.20                     | 9.40       | 4.90                  | 5.60       | 230   | 14                         |
|        |                         | Class 2       | 9.70                     | 11.20      | 6.00                  | 6.90       | 230   | 14                         |
|        |                         | Class 3       | 11.50                    | 13.20      | 7.20                  | 8.30       | 230   | 14                         |
|        |                         | Class 4       | 14.40                    | 16.60      | 9.40                  | 10.80      | 250   | 14                         |
|        |                         | Class 5       | 17.30                    | 19.90      | 11.50                 | 13.20      | 250   | 14                         |
|        |                         | Class 6       | 23.00                    | 26.50      | 15.60                 | 18.00      | 250   | 14                         |



Table 3 (Concluded)

| SI No. | Nominal Size, DN | Class of Pipe | Both End (Thick) Portion |       | Barrel (Thin) Portion |       | Length of Thick Portion at Both Side (L1 and L3), Min | Induced Stress, Min |
|--------|------------------|---------------|--------------------------|-------|-----------------------|-------|---|---------------------|
|        |                  |               | Min                      | Max   | Min                   | Max   |   |                     |
| (1)    | mm               | mm            | mm                       | mm    | mm                    | mm    | mm  | MPa                 |
|        | (2)              | (3)           | (4)                      | (5)   | (6)                   | (7)   | (8)   | (9)                 |
| ix)    | 150              | Class 1       | 9.30                     | 10.70 | 5.70                  | 6.60  | 230   | 14                  |
|        |                  | Class 2       | 11.20                    | 12.90 | 7.10                  | 8.20  | 230   | 14                  |
|        |                  | Class 3       | 13.10                    | 15.10 | 8.40                  | 9.70  | 230   | 14                  |
|        |                  | Class 4       | 16.60                    | 19.10 | 11.00                 | 12.70 | 250   | 14                  |
|        |                  | Class 5       | 20.10                    | 23.10 | 13.60                 | 15.70 | 250   | 14                  |
|        |                  | Class 6       | 26.90                    | 31.00 | 18.40                 | 21.20 | 250   | 14                  |

NOTE — Length of thick portion (L1 and L3) at both ends of the pipe is required for thread operation for joining the pipes with each other with couplers.

Table 4 Dimensional Details of Column Pipe Couplers

(Clause 7.1)

All dimensions in millimetres.

| SI No. | Nominal Size, DN | Mean Outer Diameter of Column Pipe Coupler, <i>a</i> , Min |                    | Internal Diameter of Column Pipe Coupler, <i>b</i> , Max |
|--------|------------------|--|--------------------|--|
|        |                  | For Classes 1 to 3   | For Classes 4 to 7 |  |
| (1)    | (2)              | (3)  | (4)                | (5)  |
| i)     | 25               | 45.0   | 51.0               | 29.0   |
| ii)    | 32               | 55.0   | 60.0               | 38.0   |
| iii)   | 40               | 62.0   | 72.0               | 44.0   |
| iv)    | 50               | 80.0   | 86.0               | 55.0   |
| v)     | 65               | 92.0   | 99.0               | 70.0   |
| vi)    | 80               | 108.0  | 115.0              | 83.0   |
| vii)   | 100              | 136  | 145.0              | 108.0  |
| viii)  | 125              | 165  | 175.0              | 134.0  |
| ix)    | 150              | 190  | 205.0              | 159.0  |

Table 5 Thread Dimensions for Both Male Ends of Column Pipe

(Clauses 7.1 and 8.3)

All dimensions in millimetres.

| SI No. | Nominal Size, DN | Male End (Tolerance $\begin{smallmatrix} +0.0 \\ -0.3 \end{smallmatrix}$ ) |                | Free End Side Length, Min |       | Permanent End Side Length, Min |       | Pitch |
|--------|------------------|--|----------------|---------------------------|-------|--------------------------------|-------|-------|
|        |                  | Major Diameter   | Minor Diameter | $L_f$                     | $l_f$ | $L_p$                          | $l_p$ |       |
| (1)    | (2)              | (3)  | (4)            | (5)                       | (6)   | (7)                            | (8)   | (9)   |
| i)     | 25               | 32.80  | 30.80          | 56.0                      | 3.0   | 60.0                           | 12    | 3.0   |
| ii)    | 32               | 41.50  | 39.50          | 56.0                      | 3.0   | 60.0                           | 12    | 3.0   |
| iii)   | 40               | 47.50  | 45.50          | 56.0                      | 3.0   | 60.0                           | 12    | 3.0   |
| iv)    | 50               | 59.50  | 56.50          | 64.0                      | 3.5   | 80.0                           | 12    | 4.0   |
| v)     | 65               | 74.50  | 71.50          | 64.0                      | 3.5   | 80.0                           | 12    | 4.0   |
| vi)    | 80               | 87.50  | 84.30          | 64.0                      | 3.5   | 85.0                           | 14    | 4.0   |
| vii)   | 100              | 112.50   | 109.10         | 74.0                      | 5.0   | 85.0                           | 14    | 6.0   |
| viii)  | 125              | 139.50   | 135.50         | 84.0                      | 5.0   | 104.0                          | 14    | 6.0   |
| ix)    | 150              | 164.50   | 160.50         | 84.0                      | 5.0   | 104.0                          | 14    | 6.0   |

**Table 6 Thread Dimensions for Both Female Ends of Column Pipe Coupler**

(Clauses 7.1 and 8.3)

All dimensions in millimetres.

| Sl No. | Nominal Size,<br><i>DN</i> | Female End<br>(Tolerance $^{+0.3}_{0.0}$ ) |                   | Free End Side<br>Length, <i>Min</i> |       | Permanent End<br>Side Length, <i>Min</i> |       | Pitch |
|--------|----------------------------|--|-------------------|-------------------------------------|-------|--|-------|-------|
|        |                            | Major<br>Diameter                          | Minor<br>Diameter | $L_f$                               | $l_f$ | $L_p$                                    | $l_p$ |       |
| (1)    | (2)                        | (3)  | (4)               | (5)                                 | (6)   | (7)                                      | (8)   | (9)   |
| i)     | 25                         | 33.20                                      | 31.20             | 60.0                                | 15    | 51.0                                     | 14    | 3.0   |
| ii)    | 32                         | 41.90                                      | 39.90             | 60.6                                | 15    | 51.0                                     | 14    | 3.0   |
| iii)   | 40                         | 47.90                                      | 45.90             | 60.6                                | 15    | 51.6                                     | 14    | 3.0   |
| iv)    | 50                         | 60.00                                      | 57.00             | 66.3                                | 15    | 72.3                                     | 14    | 4.0   |
| v)     | 65                         | 75.00                                      | 72.00             | 66.3                                | 15    | 72.3                                     | 14    | 4.0   |
| vi)    | 80                         | 88.20                                      | 85.00             | 66.3                                | 15    | 77.3                                     | 14    | 4.0   |
| vii)   | 100                        | 113.30                                     | 109.90            | 76.8                                | 15    | 77.8                                     | 14    | 6.0   |
| viii)  | 125                        | 140.30                                     | 136.30            | 86.8                                | 15    | 95.8                                     | 14    | 6.0   |
| ix)    | 150                        | 165.30                                     | 161.30            | 86.8                                | 15    | 95.8                                     | 14    | 6.0   |

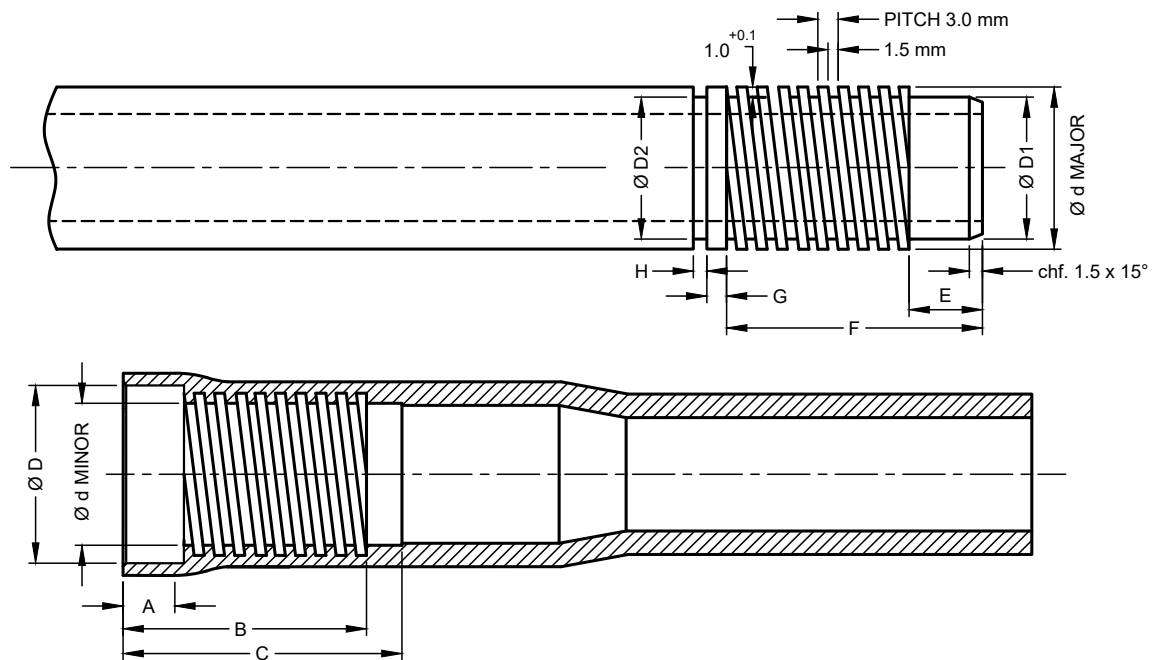

All dimensions in millimetres.

**FIG. 2 BELL ENDED COLUMN PIPES WITH INTERNAL THREADS AT ONE END AND SPIGOT AT ANOTHER END WITH EXTERNAL THREADS**

**Table 7 Dimensions of Bell-Ended Pipes***(Clause 7.1)*

All dimensions in millimetres.

| Sl No. | Nominal Size, DN | $D_{-0.0}^{+0.2}$ | $D_{1-0.2}^{+0.0}$ | $D_{2-0.2}^{+0.0}$ | Major $d_{-0.2}^{+0.0}$ | Minor $d_{-0.0}^{+0.2}$ | $A_{-0.0}^{+2.0}$ | $B_{-0.0}^{+2.0}$ | $C_{-0.0}^{+2.0}$ | $E_{-0.2}^{+0.0}$ | $F_{-0.2}^{+0.0}$ | $G_{-0.0}^{+0.1}$ | $H_{-0.2}^{+0.0}$ | Thread Depth | Pitch |
|--------|------------------|-------------------|--------------------|--------------------|-------------------------|-------------------------|-------------------|-------------------|-------------------|-------------------|-------------------|-------------------|-------------------|--------------|-------|
| (1)    | (2)              | (3)               | (4)                | (5)                | (6)                     | (7)                     | (8)               | (9)               | (10)              | (11)              | (12)              | (13)              | (14)              | (15)         | (16)  |
| i)     | 25               | 35.2              | 30.6               | 31.1               | 32.8                    | 31.2                    | 8                 | 51                | 60                | 12                | 48                | 2.5               | 3.0               | 1.0          | 3.0   |
| ii)    | 32               | 43.4              | 39.3               | 39.8               | 41.5                    | 39.9                    | 8                 | 51                | 60                | 12                | 48                | 2.5               | 3.0               | 1.0          | 3.0   |
| iii)   | 40               | 49.4              | 45.3               | 45.8               | 47.5                    | 45.9                    | 8                 | 51                | 60                | 12                | 48                | 2.5               | 3.0               | 1.0          | 3.0   |

#### 9.4 Tensile Strength and Elongation at Break

When tested by the method described in IS 12235 (Part 13), the average tensile strength of three test specimens cut longitudinally from barrel (thin) portion of the same pipe at maximum load shall not be less than 45 MPa and the elongation at break shall not be less than 30 percent.

The specimen for the test shall be prepared from a section of the pipe. The specimens shall be cut or machined from lengths of pipe in the longitudinal direction, that is, along the pipe axis.

#### 9.5 Ultimate Breaking load

Ultimate breaking load shall be checked at both sides of the threaded assembly of column socketed pipe or cut piece of thick end portion of pipe with coupler. Threaded assembly shall be fitted in suitable end fixtures. End fixtures shall then be mounted on the universal testing machine (UTM) of adequate capacity. The test temperature and test speed shall be  $(27 \pm 2)$  °C and 10 mm/min, respectively. The jaws of the UTM shall be pulled until the assembly breaks. The pick load shall be noted. Minimum pick load shall be as per Table 9 for all size and class of pipes. A typical ultimate breaking load assembly is shown in Fig. 3 for reference.

#### 9.6 Izod Impact Strength Test

When tested in accordance with the method described in Annex B, the notch izod-impact strength shall not be less than 60 J/m.

#### 9.7 Resistance to Dichloromethane Test

When tested in accordance with the method described in IS 12235 (Part 11), there shall be no attack observed on any part of the surface of test piece taken from pipe and coupler.

#### 9.8 Density

When tested by the method described in IS 12235 (Part 14), the density of the material of the pipe and coupler shall be between 1.40 g/cm<sup>3</sup> and 1.44 g/cm<sup>3</sup>.

#### 9.9 Vicat Softening Temperature

The vicat softening temperature shall not be less than 80 °C when tested by the method described in IS 12235 (Part 2) for both pipe and coupler. The test may be done on a test piece cut from a sample of the pipe used for some other test (such as density or resistance to external blows) as long as that sample has not been subjected to conditions that could influence the Vicat softening temperature.

**Table 8 Total Mass of Striker and Height of Free Fall for Resistance to External Blows Test**

(Clause 9.2)

| SI No. | Nominal Size, DN | Total Mass of Striker<br>kg | Height of Free Fall<br>mm | Number of Equidistant Lines to be Drawn |
|--------|------------------|-----------------------------|---------------------------|---|
| (1)    | (2)              | (3)                         | (4)                       | (5)                                     |
| i)     | 25               | 0.25 ± 0.5 %                | 1 000 ± 10                | 1                                       |
| ii)    | 32               | 0.25 ± 0.5 %                | 1 000 ± 10                | 1                                       |
| iii)   | 40               | 0.25 ± 0.5 %                | 1 000 ± 10                | 3                                       |
| iv)    | 50               | 0.25 ± 0.5 %                | 2 000 ± 10                | 3                                       |
| v)     | 65               | 0.25 ± 0.5 %                | 2 000 ± 10                | 4                                       |
| vi)    | 80               | 0.50 ± 0.5 %                | 2 000 ± 10                | 4                                       |
| vii)   | 100              | 0.50 ± 0.5 %                | 2 000 ± 10                | 6                                       |
| viii)  | 125              | 1.00 ± 0.5 %                | 2 000 ± 10                | 8                                       |
| ix)    | 150              | 1.00 ± 0.5 %                | 2 000 ± 10                | 8                                       |

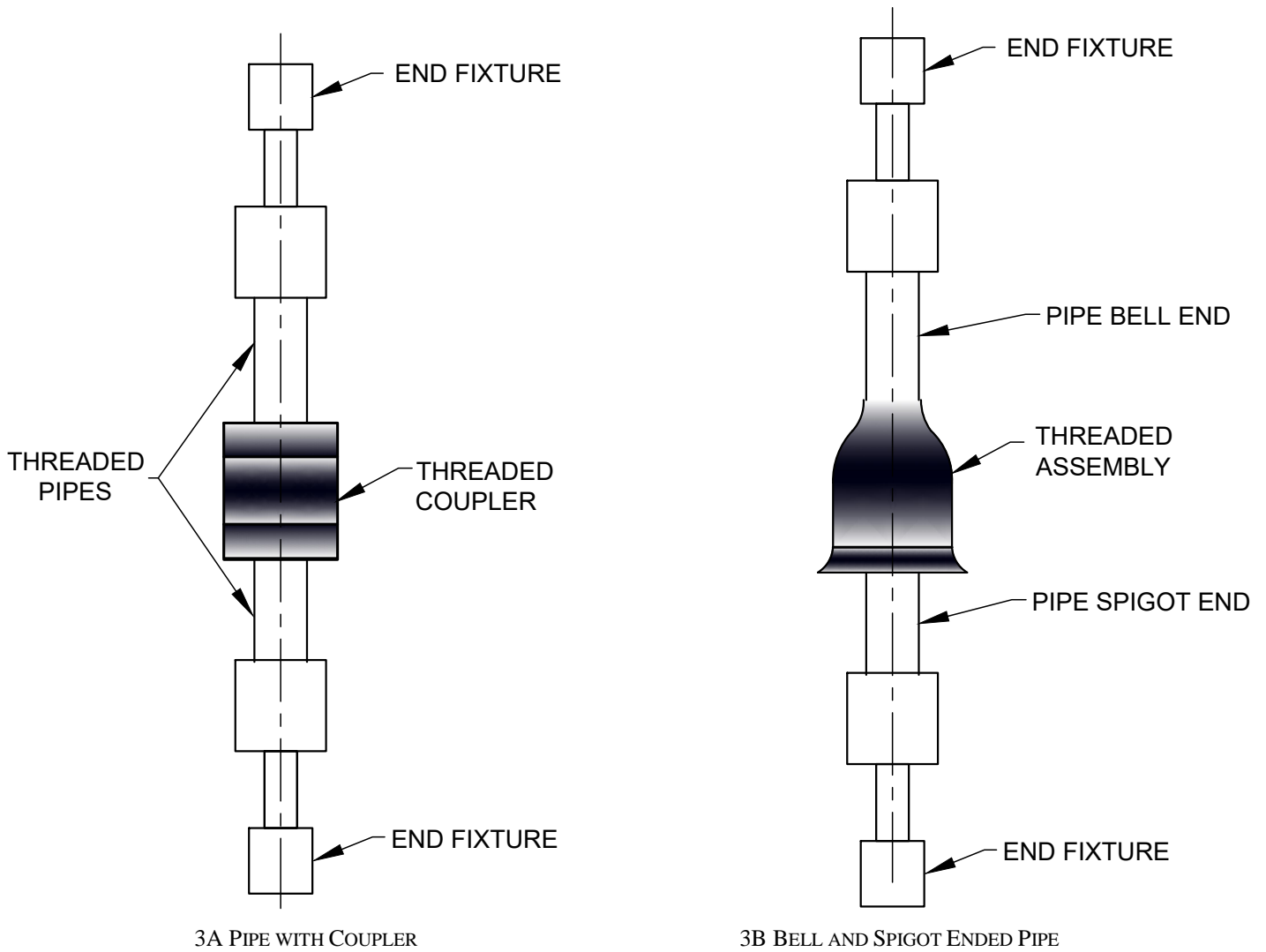

FIG. 3 TYPICAL ULTIMATE BREAKING LOAD ASSEMBLY

**Table 9 Ultimate Breaking Load**

(Clause 9.5)

| SI No. | Nominal Diameter, <i>DN</i> | Class of Pipe | Ultimate Breaking Load, <i>Min</i><br>kg<br>(4) |
|--------|-----------------------------|---------------|---|
| (1)    | (2)                         | (3)           | (4)   |
| i)     | 25                          | Class 1       | 588   |
|        |                             | Class 2       | 717   |
|        |                             | Class 3       | 802   |
|        |                             | Class 4       | 1 008   |
| ii)    | 32                          | Class 1       | 859   |
|        |                             | Class 2       | 1 023   |
|        |                             | Class 3       | 1 238   |
|        |                             | Class 4       | 1 552   |
|        |                             | Class 5       | 1 906   |
|        |                             | Class 6       | 2 479   |
|        |                             | Class 7       | 2 669   |

Table 9 (Concluded)

| SI No. | Nominal Diameter, <i>DN</i> | Class of Pipe | Ultimate Breaking Load, <i>Min</i><br>kg |
|--------|-----------------------------|---------------|--|
| (1)    | (2)                         | (3)           | (4)                                      |
| iii)   | 40                          | Class 1       | 1 113                                    |
|        |                             | Class 2       | 1 363                                    |
|        |                             | Class 3       | 1 609                                    |
|        |                             | Class 4       | 2 027                                    |
|        |                             | Class 5       | 2 489                                    |
|        |                             | Class 6       | 3 253                                    |
|        |                             | Class 7       | 3 815                                    |
| iv)    | 50                          | Class 1       | 1 720                                    |
|        |                             | Class 2       | 2 111                                    |
|        |                             | Class 3       | 2 495                                    |
|        |                             | Class 4       | 3 168                                    |
|        |                             | Class 5       | 3 889                                    |
|        |                             | Class 6       | 5 050                                    |
|        |                             | Class 7       | 6 007                                    |
| v)     | 65                          | Class 1       | 2 662                                    |
|        |                             | Class 2       | 3 346                                    |
|        |                             | Class 3       | 3 922                                    |
|        |                             | Class 4       | 4 950                                    |
|        |                             | Class 5       | 6 033                                    |
|        |                             | Class 6       | 7 912                                    |
| vi)    | 80                          | Class 1       | 3 722                                    |
|        |                             | Class 2       | 4 525                                    |
|        |                             | Class 3       | 5 314                                    |
|        |                             | Class 4       | 6 851                                    |
|        |                             | Class 5       | 8 332                                    |
|        |                             | Class 6       | 10 838                                   |
| vii)   | 100                         | Class 1       | 6 018                                    |
|        |                             | Class 2       | 7 491                                    |
|        |                             | Class 3       | 8 793                                    |
|        |                             | Class 4       | 11 329                                   |
|        |                             | Class 5       | 13 639                                   |
|        |                             | Class 6       | 17 891                                   |
| viii)  | 125                         | Class 1       | 9 362                                    |
|        |                             | Class 2       | 11 371                                   |
|        |                             | Class 3       | 13 523                                   |
|        |                             | Class 4       | 17 362                                   |
|        |                             | Class 5       | 20 899                                   |
|        |                             | Class 6       | 27 446                                   |
| ix)    | 150                         | Class 1       | 12 842                                   |
|        |                             | Class 2       | 15 855                                   |
|        |                             | Class 3       | 18 604                                   |
|        |                             | Class 4       | 23 905                                   |
|        |                             | Class 5       | 29 120                                   |
|        |                             | Class 6       | 38 149                                   |

### 9.10 Effect on Water

The pipes shall not have any detrimental effect on the composition of water flowing through them. When tested in accordance with the method described in IS 12235 (Part 4) and IS 12235 (Part 10), the quantities of lead, dialkyl tin C4 and higher homologues (measured as tin) and any other toxic substances extracted from the internal walls of the pipes shall not exceed the concentrations as specified in 10.3 of IS 4985 and meet the other requirements given in 10.3.1 of IS 4985.

NOTE — Implementation of the phase-out programme of the Government of India for use of lead stabilizers in PVC pipe and fitting manufacturing shall be borne in mind.

### 9.11 Hydrostatic Pressure Test

When subjected to internal hydrostatic pressure test in accordance with the procedure given in IS 12235 (Part 8/Sec 1), the pipe shall not fail during the prescribed test duration. The temperature and duration of the test shall conform to the requirement given in Table 10. The test shall be carried out not earlier than 24 h after the pipes have been manufactured. This test should be performed on thin barrel portion.

### 9.12 Joint Leak Pressure Test

When subjected to internal hydrostatic pressure test in accordance with the procedure given in Annex C, the representative assembly of pipe and coupler or bell end side and spigot end side of pipe sample shall withstand for 1 h without rupture, separation or leakage with an internal hydrostatic pressure of 1.5 times the working pressure ( $PN$ ) at room temperature.

## 10 SAMPLING AND CRITERIA FOR CONFORMITY

### 10.1 Acceptance Tests

10.1.1 The scale of sampling and criteria for conformity of a lot for acceptance tests specified in 7, 8 and 9.1 to 9.3 shall be as given in 10.1.5 and 10.1.6 read along with Table 11 and for those specified in 9.4, 9.5, 9.7, 9.8, 9.9, 9.11 and 9.12 shall be as given under 10.1.7.

10.1.2 All pipes, in a single consignment, of the same type, same size and same class, manufactured under essentially similar conditions, shall constitute a lot.

10.1.3 For ascertaining conformity of the lot to the requirements of the specification, samples shall be tested from each lot separately.

10.1.4 The pipes shall be selected at random from the lots in order to ensure randomness of selection, a random number table shall be used. For guidance on the use of random number tables, IS 4905 may be referred to. In the absence of a random number table, the following procedure may be adopted:

Starting from any pipe in the lot, count them as 1, 2, 3, etc, up to  $r$  and so on; where  $r$  is the integral part of  $N/n$ ,  $N$  being the number of pipes in the lot and  $n$  the number of pipes in the sample. Every ' $r$  th' pipe so counted shall be withdrawn so as to constitute the required sample size.

10.1.5 The number of samples given for the first sample in col (5) of Table 11 shall be taken from the lot and examined for requirements given in 7, 8 and 9.1. A pipe failing to satisfy any of these requirements shall be considered as defective. The lot shall be deemed to have satisfied the requirements if the number of defectives found in the first sample is less than or equal to the corresponding acceptance number given in col (7). The lot shall be deemed not to have met these requirements, if the number of defectives found in the first sample is greater than or equal to the corresponding rejection number given in col (8). If, however, the number of defectives found in the first sample lies between the corresponding acceptance and rejection numbers given in col (7) and (8), a second sample of the size given in col (5) shall be taken and examined for these requirements. The lot shall be considered to have satisfied these requirements if the number of defectives found in the cumulative sample is less than or equal to the corresponding acceptance number given in col (7), otherwise not.

**Table 10 Test Parameters for Internal Hydrostatic Pressure Test**

(Clause 9.11)

| Sl No. | Test            | Test Temperature,<br><i>Min</i> | Test Duration<br>(Minimum Holding<br>Time) | Test Pressure, <i>Min</i> |
|--------|-----------------|---------------------------------|--|---------------------------|
| (1)    | (2)             | °C<br>(3)                       | h<br>(4)                                   | MPa<br>(5)                |
| i)     | Acceptance Test | 27 ± 2                          | 1  | 2.5 × PN                  |

**10.1.6** The lot, having satisfied the requirements under **10.1.5** shall be tested for the requirements in **9.2** and **9.3**. For this purpose, a sub-sample from those tested under **10.1.5** shall be drawn as given in col (10) of Table 11 for the first/second sample size. The lot shall be deemed to have met the requirements given in the standard, if the number of defectives found in the first sample is less than or equal to the corresponding acceptance number given in col (12). The lot shall be deemed not to have met these requirements, if the number of defectives found in the first sample is greater than or equal to the corresponding rejection number given in col (13). If, however, the number of defectives found in the first sample lies between the corresponding acceptance and rejection numbers given in col (12) and (13), a second sample of the size given in col (10) shall be taken and tested for the requirement, the lot shall be deemed to have satisfied the requirements, if the number of defectives found in the cumulative sample is less than or equal to the corresponding acceptance number given in col (12), otherwise not.

**10.1.7** The lot, having satisfied the requirements under **10.1.5** and **10.1.6**, shall be tested for **9.4, 9.5, 9.7, 9.8, 9.9, 9.11** and **9.12**. For this, a sub-sample of 3 pipes from each lot irrespective of the lot size shall be selected from those tested under **10.1.5** and **10.1.6**. All pipes in the sub-sample shall be tested for requirements as specified in **9.4, 9.5, 9.7, 9.8, 9.9, 9.11** and **9.12**. The lot shall be considered to have passed only if no failure is reported.

## **10.2 Type Tests**

These tests are intended to prove the suitability and performance of pipes whenever there is a change in the composition, size and type of pipe as well as in the method/technique in the manufacturing process. Tests specified in **9.6** and **9.10** shall be taken as type test.

### **10.2.1 Izod Impact Strength Test**

**10.2.1.1** For this type test, the manufacturer or the supplier shall furnish to the testing authority three samples of pipes of different diameters and different classes of the same type (selected preferably from a regular production lot).

**10.2.1.2** Three samples so selected shall be tested for compliance with the requirements of type test as given in **9.6**.

**10.2.1.3** If all the three samples pass the requirements of the izod impact strength test, the type test of the pipe under consideration shall be considered to be eligible for approval, which shall be normally valid for a period of one year.

**10.2.1.4** In case any of the samples fails in this test, the testing authority, at its discretion, may call for fresh samples not exceeding the original number, and subject them to the test for izod impact strength test. If, in the repeat test, no single failure occurs, the type of pipe under consideration shall be considered eligible for type approval. If any of the samples fails in the repeat test, the type of pipe shall not be approved. The manufacturer or the supplier may be asked to improve the design and resubmit the product for type approval.

**10.2.1.5** At the end of the validity period (normally one year) or earlier, if necessary, the testing authority may call for fresh samples for izod impact strength test for the purpose of type approval.



Table 11 Sampling and Acceptance Criteria

(Clauses 10.1.1, 10.1.5 and 10.1.6)

| SI No. | Number of Pipes in the Lot | Nominal Size, <i>DN</i><br>mm | For Tests under 7, 8 and 9.1 |      |                        |                   |                  | For Tests under 9.2 and 9.3 |      |                        |                   |                  |
|--------|----------------------------|-------------------------------|------------------------------|------|------------------------|-------------------|------------------|-----------------------------|------|------------------------|-------------------|------------------|
|        |                            |                               | Sample                       |      | Cumulative Sample Size | Acceptance Number | Rejection Number | Sub-Sample                  |      | Cumulative Sample Size | Acceptance Number | Rejection Number |
|        |                            |                               | No.                          | Size |                        |                   |                  | No.                         | Size |                        |                   |                  |
| (1)    | (2)                        | (3)                           | (4)                          | (5)  | (6)                    | (7)               | (8)              | (9)                         | (10) | (11)                   | (12)              | (13)             |
| i)     | Up to<br>1 000             | ≤ 100                         | 1st                          | 13   | 13                     | 0                 | 2                | 1st                         | 3    | 3                      | 0                 | 2                |
|        |                            |                               | 2nd                          | 13   | 26                     | 1                 | 2                | 2nd                         | 3    | 6                      | 1                 | 2                |
|        |                            | > 100                         | 1st                          | 5    | 5                      | 0                 | 2                | 1st                         | 3    | 3                      | 0                 | 2                |
|        |                            |                               | 2nd                          | 5    | 10                     | 1                 | 2                | 2nd                         | 3    | 6                      | 1                 | 2                |
| ii)    | 1 001 -<br>3 000           | ≤ 100                         | 1st                          | 20   | 20                     | 0                 | 3                | 1st                         | 3    | 3                      | 0                 | 2                |
|        |                            |                               | 2nd                          | 20   | 40                     | 3                 | 4                | 2nd                         | 3    | 6                      | 1                 | 2                |
|        |                            | > 100                         | 1st                          | 8    | 8                      | 0                 | 2                | 1st                         | 3    | 3                      | 0                 | 2                |
|        |                            |                               | 2nd                          | 8    | 16                     | 1                 | 2                | 2nd                         | 3    | 6                      | 1                 | 2                |
| iii)   | 3 001-<br>10 000           | ≤ 100                         | 1st                          | 32   | 32                     | 0                 | 3                | 1st                         | 3    | 3                      | 0                 | 2                |
|        |                            |                               | 2nd                          | 32   | 64                     | 3                 | 4                | 2nd                         | 3    | 6                      | 1                 | 2                |
|        |                            | > 100                         | 1st                          | 13   | 13                     | 0                 | 3                | 1st                         | 3    | 3                      | 0                 | 2                |
|        |                            |                               | 2nd                          | 13   | 26                     | 3                 | 4                | 2nd                         | 3    | 6                      | 1                 | 2                |
| iv)    | 10 001<br>and<br>above     | ≤ 100                         | 1st                          | 50   | 50                     | 2                 | 5                | 1st                         | 6    | 6                      | 0                 | 2                |
|        |                            |                               | 2nd                          | 50   | 100                    | 6                 | 7                | 2nd                         | 6    | 12                     | 2                 | 3                |
|        |                            | > 100                         | 1st                          | 20   | 20                     | 1                 | 4                | 1st                         | 4    | 4                      | 0                 | 2                |
|        |                            |                               | 2nd                          | 20   | 40                     | 4                 | 5                | 2nd                         | 4    | 8                      | 1                 | 2                |

NOTE — For test under 9.2, the numbers mentioned in col (10) to col (13) represent the number of times the test is to be carried out. They do not represent the number of pipe samples nor the number of blows nor the number of failures.

**10.2.2 Test for Effect on Water**

**10.2.2.1** For this type test, the manufacturer or the supplier shall furnish to the testing authority three samples of the smallest size of pipe taken from each machine (selected preferably from a regular production lot).

**10.2.2.2** Three samples so selected shall be tested for compliance with the requirements for effect on water as given in **9.10**.

**10.2.2.3** If all three samples pass the requirements for effect on water, the type test of the pipe under consideration shall be considered to be eligible for approval, which shall be normally valid for a period of one year.

**10.2.2.4** In case any of the samples fails in this test, the testing authority, at its discretion, may call for fresh samples not exceeding the original number, and subject them to the test for effect on water. If, in the repeat test, no single failure occurs, the type of pipe under consideration shall be considered eligible for type approval. If any of the samples fails in the repeat test, the type of pipe shall not be approved. The manufacturer or the supplier may be asked to improve the design and resubmit the product for type approval.

**10.2.2.5** At the end of the validity period (normally one year) or earlier, if necessary, the testing authority may call for fresh samples for effect on water test for the purpose of type approval.

**11 MARKING**

**11.1** Each pipe shall be clearly and indelibly marked in ink/paint at intervals of not more than 1 metre, and strip in colour as indicated in **11.2**. The markings shall show the following:

- a) Manufacturer's name or trade-mark;

- b) Nominal size (*DN*);  
 c) Class of pipe and working pressure rating;  
 d) The phrase 'column pipe'; and  
 e) Lot number/Batch number containing information of date of manufacture.

The lot number/batch number shall include the details of production in the following manner:

| <i>Year</i> | <i>Month</i> | <i>Day</i> | <i>Machine No.</i> | <i>Shift</i> |
|-------------|--------------|------------|--------------------|--------------|
| XXXX        | XX           | XX         | XXX                | X            |

**11.2** The information according to **11.1** shall be marked in black colour and a strip of minimum 3 mm width of colour as indicated below for different classes of pipes shall be provided. Alternatively, the information to be marked/painted can be printed in colour as given below without any strip.

| <i>Sl No.</i> | <i>Class</i> | <i>Colour of Marking/Strip</i> |
|---------------|--------------|--------------------------------|
| (1)           | (2)          | (3)                            |
| i)            | Class 1      | Red                            |
| ii)           | Class 2      | Blue                           |
| iii)          | Class 3      | Green                          |
| iv)           | Class 4      | Brown                          |
| v)            | Class 5      | Yellow                         |
| vi)           | Class 6      | Black                          |
| vii)          | Class 7      | Pink                           |

**11.3 BIS Certification Marking**

Each column pipe and coupler conforming to the requirements of this standard may be certified as per the conformity assessment schemes under the provisions of the *Bureau of Indian Standards Act, 2016* and the Rules and Regulations framed thereunder, and the pipe may be marked with the Standard Mark.

## ANNEX A

(Clause 2)

## LIST OF REFERRED STANDARDS

| <i>IS No.</i>                       | <i>Title</i>  | <i>IS No.</i>            | <i>Title</i>   |
|-------------------------------------|---|--------------------------|--|
| IS 4669 : 1968                      | Methods of tests for polyvinyl chloride resins  | IS 12235                 | Thermoplastics pipes and fittings — Methods of test ( <i>first revision</i> )  |
| IS 4905 : 2015/<br>ISO 24153 : 2009 | Random sampling and randomization procedures ( <i>first revision</i> )  | (Part 1) : 2004          | Measurement of dimensions  |
| IS 4985 : 2021                      | Unplasticized PVC pipes for water supplies — Specification ( <i>fourth revision</i> )   | (Part 2) : 2004          | Determination of vicat softening temperature   |
| IS 5382 : 2018/<br>ISO 4633 : 2015  | Rubber seals — Joint rings for water supply, drainage and sewerage pipelines — Specification for materials ( <i>second revision</i> )                                 | (Part 4) : 2004          | Determining the detrimental effect on the composition of water   |
| IS 10148 : 2023                     | Positive list of constituents of polyvinyl chloride (PVC) and its copolymers in contact with foodstuffs, pharmaceuticals and drinking water ( <i>first revision</i> ) | (Part 8/Sec 1) :<br>2004 | Resistance to internal hydrostatic pressure, Section 1 Resistance to internal hydrostatic pressure at constant internal water pressure |
| IS 10151 : 2019                     | Polyvinyl chloride (PVC) and its copolymers for its safe use in contact with foodstuffs, pharmaceuticals and drinking water — Specification ( <i>first revision</i> ) | (Part 9) : 2004          | Resistance to external blows (impact resistance) at 0 °C (round the-clock method)  |
|                                     |   | (Part 10) : 2004         | Determination of organotin as tin aqueous solution   |
|                                     |   | (Part 11) : 2004         | Resistance to dichloromethane at specified temperature   |
|                                     |   | (Part 13) : 2004         | Determination of tensile strength and elongation   |
|                                     |   | (Part 14) : 2004         | Determination of density/relative density (specific gravity)   |
|                                     |   | (Part 19) : 2004         | Flattening test  |

## ANNEX B

(Clauses 4.1.1 and 9.6)

## METHOD OF TEST FOR DETERMINATION OF IZOD IMPACT STRENGTH

**B-1 GENERAL**

Izod impact strength is the striking energy absorbed by a notched test specimen relative to the cross-sectional area. This test is used to assess toughness or brittleness of the test specimen.

**B-2 APPARATUS**

Apparatus required for the test are:

- a) V-Notch cutting Machine; and
- b) Impact testing machine as per the requirements given below;
  - 1) The striker of the pendulum shall be hardened steel and shall be a cylindrical surface having a radius of curvature of  $(0.80 \pm 0.20)$  mm with its axis horizontal and perpendicular to the plane of swing of the pendulum.
  - 2) The position of the pendulum holding and releasing mechanism shall be such that the vertical height of fall of the striker shall be  $(610 \pm 2)$  mm. This will produce a velocity of the striker at the moment of impact of approximately 3.5 m/s.

**B-3 TEST SPECIMEN****B-3.1 Shape and Size**

Test specimen shall be as per Fig. 4.

**B-3.2 Preparation**

The specimen after cutting and grinding to the specified size as above, shall be subjected to

conditioning at temperature of  $(23 \pm 2)$  °C and  $(50 \pm 5)$  percent relative humidity in the environmental test chamber for a minimum duration of 16 h. Five test specimens shall be prepared for the test from each pipe sample.

**B-4 PROCEDURE**

**B-4.1** The test shall be conducted in the same atmosphere as that used for conditioning, unless otherwise agreed upon by the interested parties, for example for testing at high or low temperature. The test piece shall be mounted on the pendulum impact testing machine as shown in Fig. 5 and the hammer shall be released to strike on the front side of the notch of the test specimen. Striking energy absorbed by the test specimen in joule shall be indicated on the scale of the impact testing machine.

**B-4.2** The test piece shall be kept in vertical position while testing the impact, and before striking the specimen, the dissipation energy shall be noted by releasing the hammer without test specimen. This dissipation energy shall be subtracted from the energy absorbed by specimen during the test and the reading shall be noted as  $G_0$ , in joule.

Izod impact strength of the specimen shall be calculated as:

$$H_n = \frac{G_0 \times 1000}{F} \text{ J/m}$$

where

$H_n$  = Izod impact strength;

$G_0$  = Noted energy; and

$F$  = Actual thickness of the specimen.

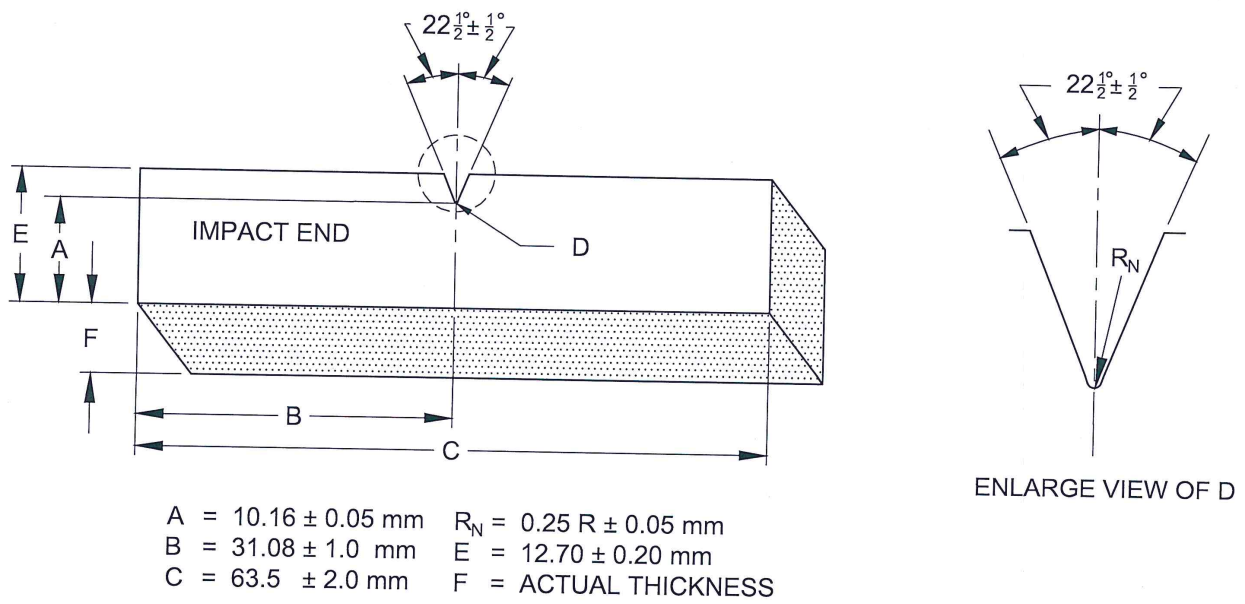

FIG.4 DIMENSIONS OF IZOD IMPACT TEST SPECIMEN

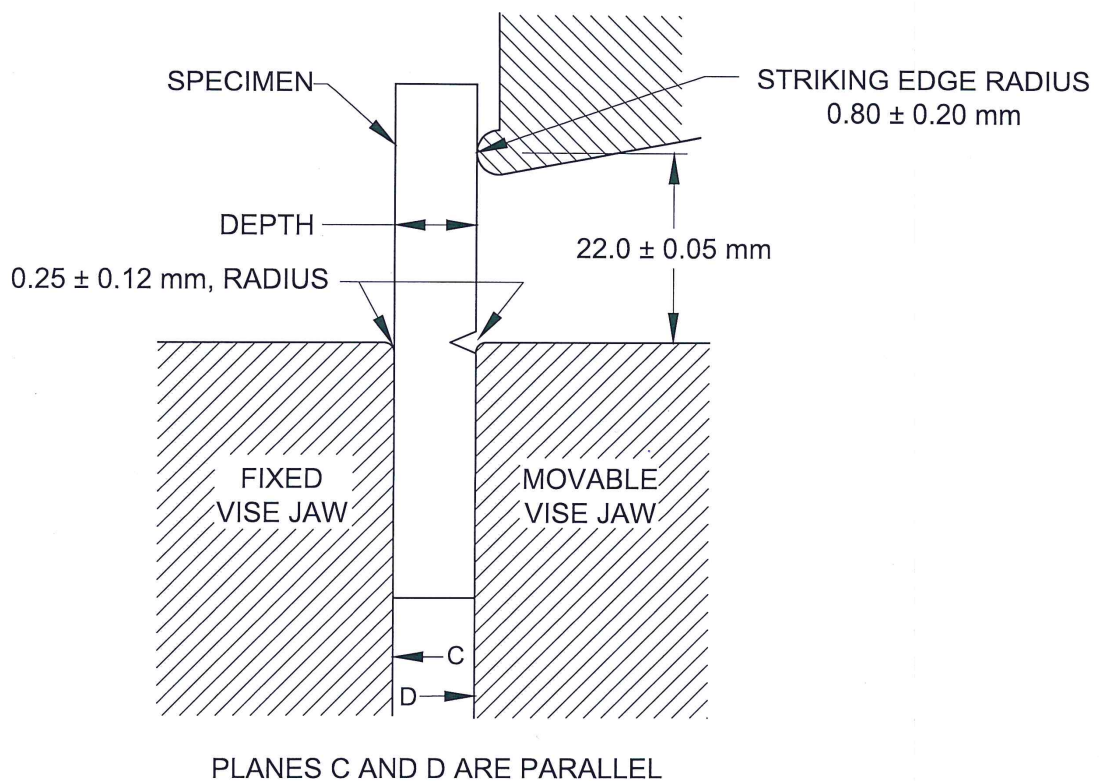

FIG. 5 RELATIONSHIP OF VISE, SPECIMEN AND STRIKING EDGE

## ANNEX C

(Clause 9.12)

## JOINT LEAK PRESSURE TEST

## C-1 SCOPE

**C-1.1** This Annex specifies the method for joint leak pressure test for the assembly of threaded pipe and coupler and that of threaded bell end socket and threaded spigot pipe.

## C-2 TEST PIECES

**C-2.1** Typical assembly of specimen for joint leak pressure test is shown in Fig. 6.

**C-2.2** For the assembly of coupler type threaded column pipe, take 2 numbers of 300 mm long cut piece of one side threaded column pipe and 1 number of threaded coupler. Assemble 2 numbers of pipe cut piece at both end of the coupler, that is, at its permanent and temporary side, as shown in Fig. 6A. Seal the joint of pipe and coupler with a sealing ring as per the standard design of manufacturer for practical use.

**C-2.3** For the assembly of bell end pipe, take one

number of 300 mm long pipe having threaded bell end (female thread) at one side and other side plain and 1 number of 300 mm long pipe having spigot end (male thread) at one side and other side plain. Assemble spigot end pipe into the bell end socket as shown in Fig. 6B. Seal the joint with a sealing ring as per the standard design of manufacturer for practical use.

## C-3 TEST METHOD

After assembly, close both end of the pipe with suitable metal end caps. Fill the water into the assembly. This test should be performed at the floor and all precautions shall be taken for ensuring human safety. Attach assembly with hydrostatic pressure testing machine. Apply the hydrostatic pressure of 1.5 times the pressure rating ( $PN$ ) for a period of 1 h. During the testing, monitor for any leakage from the coupler and pipe junction or pipe and bell end junction.

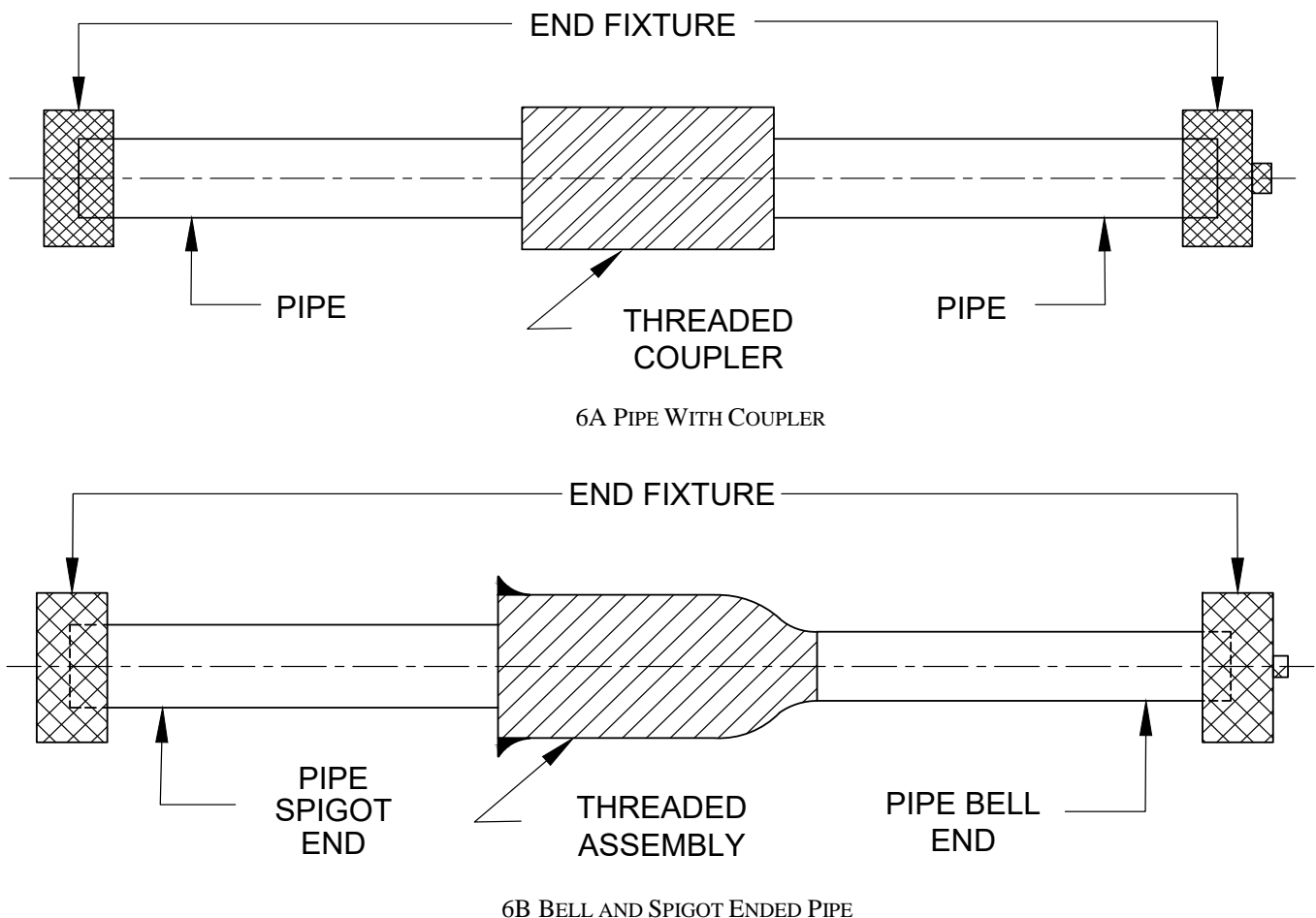

FIG. 6 TYPICAL ASSEMBLY OF SPECIMEN FOR JOINT LEAK PRESSURE TEST

## ANNEX D

(Foreword)

## COMMITTEE COMPOSITION

Plastic Piping System Sectional Committee, CED 50

| <i>Organization</i>   | <i>Representative(s)</i>   |
|---|--|
| In Personal Capacity ( <i>Vice Chancellor, Ravenshaw University, Cuttack - 753003</i> ) | DR S. K. NAYAK ( <i>Chairperson</i> )  |
| Borouge India Pvt Ltd, Mumbai   | SHRI PRASHANT D. NIKHADE   |
| Brihan Mumbai Licensed Plumbers Association, Mumbai                                     | SHRI KISHOR V. MERCHANT<br>SHRI BIJAL M. SHAH ( <i>Alternate</i> )   |
| Central Institute of Plastic Engineering and Technology, Chennai                        | DR S. N. YADAV<br>SHRI D. ANJANEYA SHARMA ( <i>Alternate</i> )   |
| Central Public Health Environmental Engineering Organization, New Delhi                 | DR RAMAKANT<br>SHRI VIPIN KUMAR PATEL ( <i>Alternate</i> )   |
| Central Public Works Department, New Delhi  | SHRI M. K. MALLICK<br>SHRI DIVAKAR AGRAWAL ( <i>Alternate</i> )  |
| Chennai Metropolitan Water Supply & Sewerage Board, Chennai                             | ENGINEERING DIRECTOR<br>SUPERINTENDING ENGINEER (P&D) ( <i>Alternate</i> )                                     |
| CSIR - Central Building Research Institute, Roorkee                                     | DR B. SINGH<br>SHRI RAJIV KUMAR ( <i>Alternate</i> )   |
| CSIR - National Environmental Engineering Research Institute, Nagpur                    | DR (SHRIMATI) ABHA SARGONKAR<br>DR RITESH VIJAY ( <i>Alternate</i> )   |
| Delhi Development Authority, New Delhi  | SUPERINTENDING ENGINEER (D)<br>EXECUTIVE ENGINEER (R&D) ( <i>Alternate</i> )                                   |
| Delhi Jal Board, New Delhi  | SHRI Y. K. SHARMA<br>SHRI S. L. MEENA ( <i>Alternate</i> )   |
| Department of Chemical & Petrochemicals Govt of India, New Delhi                        | JOINT INDUSTRIAL ADVISOR   |
| Finolex Industries Limited, Pune  | SHRI ARUN SONAWANE<br>SHRI D. J. SALUNKE ( <i>Alternate</i> )  |
| GAIL India Limited, New Delhi   | SHRI MANISH KHANDELWAL<br>SHRI KULDEEP NEGI ( <i>Alternate I</i> )<br>SHRI NITIN GUPTA ( <i>Alternate II</i> ) |
| Haldia Petrochemicals Ltd, Kolkata  | SHRI RAJ K. DATTA<br>SHRI AMARTYA MAITY ( <i>Alternate</i> )   |
| HPCL - Mittal Energy Ltd, Noida   | SHRI VINEET KUMAR GUPTA<br>SHRI ALAKESH GHOSH ( <i>Alternate</i> )   |

| <i>Organization</i>  | <i>Representative(s)</i>   |
|--|--|
| HSIL Ltd (Pipe Division), Hyderabad  | SHRI TUSHAR LOKARE<br>SHRI VINOY KUMAR ( <i>Alternate</i> )  |
| Indian Oil Corporation Ltd, Panipat  | SHRI SUMIT BASU<br>SHRI RAJA PODDAR ( <i>Alternate I</i> )<br>SHRI NAVEEN GARG ( <i>Alternate II</i> ) |
| Jain Irrigation System Limited, Jalgaon  | SHRI S. NARAYANASWAMI<br>SHRI P. H. CHAUDHARI ( <i>Alternate</i> )                                     |
| Mahindra EPC Irrigation Ltd, Nashik  | SHRI SANKAR KUMAR MAITI<br>SHRI ASHISH KUMAR ( <i>Alternate</i> )                                      |
| Military Engineer Services, Engineer-in-Chief's Branch, Integrated HQ of MoD (Army), New Delhi | SHRI N. K. GOEL<br>SHRI RAJIV KHARE ( <i>Alternate</i> )   |
| Ministry of Drinking Water and Sanitation, New Delhi   | SHRI DINESH CHAND<br>SHRI SUMIT PRIYADARSHI ( <i>Alternate</i> )                                       |
| NSF Safety and Certification India Pvt Ltd, Gurugram   | SHRI B. B. SINGH<br>SHRI NASRIN KASHEFI ( <i>Alternate</i> )   |
| Panchayati Raj and Drinking Water Department, Govt. of Odisha, Bhubaneswar                     | CHIEF ENGINEER   |
| Plastindia Foundation, Mumbai  | SHRI RAJIV J. RAVAL<br>DR E. SUNDARESAN ( <i>Alternate</i> )   |
| Public Health Engineering Department, Government of Rajasthan, Jaipur                          | SUPERINTENDING ENGINEER (D&S)<br>EXECUTIVE ENGINEER (D&S) ( <i>Alternate</i> )                         |
| Reliance Industries Limited, Mumbai  | SHRI S. V. RAJU<br>SHRI SAURABH BAGHAL ( <i>Alternate</i> )  |
| RITES Limited, New Delhi   | SHRI PANKAJ AGGARWAL<br>SHRI MUKESH SINHA ( <i>Alternate</i> )   |
| Shaktiman Extrusions Pvt Ltd, Perumbavoor  | SHRI N. SURESH<br>SHRI T. S. MANOJ ( <i>Alternate</i> )  |
| Supreme Industries Limited, Mumbai   | SHRI G. K. SAXENA<br>SHRI ANUP MANDAL ( <i>Alternate</i> )   |
| Tamil Nadu Water Supply & Drainage Board, Chennai  | ENGINEERING DIRECTOR<br>JOINT CHIEF ENGINEER (COM) ( <i>Alternate</i> )                                |
| Tata Consulting Engineers Ltd, Mumbai  | REPRESENTATIVE   |
| In Personal Capacity (A-59, Sector 35, Noida - 201301)   | SHRI KANWAR A. SINGH   |
| In Personal Capacity (L-202 Metrozone, Anna Nagar West, Chennai - 600040)                      | SHRI G. K. SRINIVASAN  |



| <i>Organization</i>     | <i>Representative(s)</i>   |
|-------------------------|--|
| BIS Directorate General | SHRI ARUNKUMAR S., SCIENTIST 'E'/<br>DIRECTOR AND HEAD (CIVIL<br>ENGINEERING) REPRESENTING DIRECTOR<br>GENERAL ( <i>Ex-officio</i> ) |

*Member Secretary*  
SHRIMATI MADHURIMA MADHAV  
SCIENTIST 'D'/JOINT DIRECTOR  
(CIVIL ENGINEERING), BIS

Composition of Polyolefins and GRP Piping System Subcommittee, CED 50 : 1

| <i>Organization</i>  | <i>Representative(s)</i>   |
|--|--|
| In Personal Capacity (A-59, Sector 35, Noida - 201301)               | SHRI KANWAR A. SINGH ( <i>Convener</i> )   |
| Alom Poly Extrusion Ltd, Kolkata                                     | SHRI ARNAV JHUNJHUNWALA<br>SHRI ANIK KUMAR CHOWDHURY ( <i>Alternate</i> )                                    |
| Assam Gas Company Limited, Dibrugarh                                 | SHRI SURJAYA TAMULIK<br>SHRI AHJIT BARUAH ( <i>Alternate</i> )   |
| Bhimrajka Impex Limited, Mumbai                                      | SHRI V. K. SHARMA<br>SHRI VINOD BHIMRAJKA ( <i>Alternate</i> )   |
| Central Ground Water Board, Faridabad                                | SHRI D. N. ARUN<br>SHRI K. R. BISWAS ( <i>Alternate</i> )  |
| Central Institute of Plastics Engineering & Technology, Chennai      | DR K. PRAKALATHAN<br>DR A. K. MOHAPATRA ( <i>Alternate</i> )   |
| Central Public Works Department, New Delhi                           | SHRI M. K. SHARMA (CSQ)<br>SHRI AMAR SINGH ( <i>Alternate</i> )  |
| CSIR - National Environmental Engineering Research Institute, Nagpur | DR (SHRIMATI) ABHA SARGAONKAR<br>DR RITESH VIJAY ( <i>Alternate</i> )  |
| Chennai Water Supply & Sewerage Board, Chennai                       | ENGINEERING DIRECTOR<br>CHIEF ENGINEER (O&M) ( <i>Alternate</i> )  |
| Delhi Jal Board, New Delhi   | SHRI Y. K. SHARMA<br>SHRI S. L. MEENA ( <i>Alternate</i> )   |
| Duraline India Pvt Ltd, Mumbai                                       | SHRI RAJEEV CHATURVEDI<br>SHRI SUNIL SAXENA ( <i>Alternate</i> )   |
| Engineers India Ltd, New Delhi                                       | SHRI N. KAUL<br>SHRI R. B. BHUTDA ( <i>Alternate</i> )   |
| EPP Composite Pipes, Rajkot  | SHRI JAYRAJ SHAH<br>SHRIMATI SEEMA VAIDYA ( <i>Alternate</i> )   |
| GAIL India Limited, New Delhi  | DR DEBASISH ROY<br>SHRI MANISH KHANDELWAL ( <i>Alternate I</i> )<br>SHRI NITIN GUPTA ( <i>Alternate II</i> ) |

|   |   |
|---|---|
| Godavari Polymers Pvt Limited, Secunderabad   | SHRI C. VENKATESHWAR RAO<br>SHRI G. SRIDHAR RAO ( <i>Alternate</i> )  |
| Government E-Marketplace, New Delhi   | REPRESENTATIVE  |
| Indraprastha Gas Limited, New Delhi   | REPRESENTATIVE  |
| Industrial Toxicology Research Centre, Lucknow  | DR V. P. SHARMA<br>DR VIRENDRA MISRA ( <i>Alternate</i> )   |
| Jain Irrigation Systems Limited, Jalgaon  | SHRI M. R. KHARUL<br>SHRI M. D. CHAUDHARI ( <i>Alternate</i> )  |
| Kimplas Piping Systems Ltd, Nashik  | SHRI KIRAN SARODE<br>SHRI SANTOSH KUMAR ( <i>Alternate</i> )  |
| KITEC Industries India Limited, Mumbai  | SHRI DALIP V. KOLHE<br>SHRI MANORANJAN G. CHOUDHARY ( <i>Alternate</i> )                                    |
| Mahanagar Gas Limited, Mumbai   | SHRI K. VENUGOPAL<br>SHRIMATI NEHA KHARYA ( <i>Alternate</i> )  |
| Mahanagar Telephone Nigam Limited, New Delhi  | CHIEF ENGINEER (BW)   |
| Maruthi Tubes Pvt Ltd, Secunderabad   | SHRI MANCHAALA RAGHAVENDRA<br>SHRI M. NAGESH KUMAR ( <i>Alternate</i> )                                     |
| Military Engineer Services, Engineer- in-Chief's<br>Branch, Integrated HQ of MoD (Army),<br>New Delhi | SHRI A. K. DUBEY<br>SHRI R. K. CHAUHAN ( <i>Alternate</i> )   |
| National Test House, Kolkata  | SHRI S. P. KALIA<br>SHRI M. M. PABALKAR ( <i>Alternate</i> )  |
| Ori-Plast Limited, Kolkata  | SHRI ASHISH AGARWAL<br>SHRI SOMNATH MUKHERJEE ( <i>Alternate</i> )  |
| Public Health & Municipal Engineering Department,<br>Hyderabad  | SHRI K. SURESH KUMAR<br>SHRI CH. MALLIKARJUNUDU ( <i>Alternate</i> )  |
| Reliance Industries Limited, Mumbai   | SHRI S. V. RAJU<br>SHRI SAURABH BAGHAL ( <i>Alternate I</i> )<br>SHRI TUSHAR DONGRE ( <i>Alternate II</i> ) |
| Sangir Plastics Pvt Ltd, Mumbai   | SHRI PRASHANT TRIVEDI<br>SHRI K. V. C. DORA ( <i>Alternate</i> )  |
| In Personal Capacity ( <i>Panchjyot CHS; H-23/01<br/>Sector 29, Vashi, Navi Mumbai - 400703</i> )     | SHRI V. K. SHARMA   |

Composition of PVC and ABS Piping System Subcommittee, CED 50 : 2

| <i>Organization</i>  | <i>Representative(s)</i>                  |
|--|---|
| In Personal Capacity ( <i>L-202 Metrozone, Anna<br/>Nagar West, Chennai - 600040</i> ) | SHRI G. K. SRINIVASAN ( <b>Convener</b> ) |

| <i>Organization</i>   | <i>Representative(s)</i>   |
|---|--|
| Ashirvad Pipes Pvt Ltd, Bengaluru   | SHRI MOHAMMAD NOUFAL<br>SHRI MILIND B. MAGAR ( <i>Alternate</i> )  |
| Astral Poly Technik Ltd, Ahmedabad  | SHRI SANDEEP ENGINEER<br>SHRI LALIT TRIVEDI ( <i>Alternate</i> )   |
| Baerlocher India Additives Pvt Ltd, Mumbai  | DR SHREEKANT DIWAN<br>SHRI SACHIN BIDKAR ( <i>Alternate</i> )  |
| Central Ground Water Board, Faridabad   | SHRI D. N. ARUN<br>SHRI K. R. BISWAS ( <i>Alternate</i> )  |
| Central Institute of Plastic Engineering & Technology, Chennai                        | SHRI M. NAVANEETHAN  |
| Central Public Works Department, New Delhi  | CHIEF ENGINEER (CSQ)<br>EXECUTIVE ENGINEER (S&S) ( <i>Alternate</i> )  |
| Delhi Jal Board, New Delhi  | SHRI Y. K. SHARMA<br>SHRI S. L. MEENA ( <i>Alternate</i> )   |
| Department of Telecommunications Ministry of Communications, Govt of India, New Delhi | SHRI V. L. VENKATARAMAN<br>SHRI P. ADINARAYANA ( <i>Alternate</i> )  |
| Finolex Industries Limited, Pune  | SHRI ARUN SONAWANE<br>SHRI D. J. SALUNKE ( <i>Alternate</i> )  |
| Government E-marketplace, New Delhi   | REPRESENTATIVE   |
| Jain Irrigation Systems Limited, Jalgaon  | SHRI NARAYANASWAMI<br>SHRI M. R. KHARUL ( <i>Alternate</i> )   |
| Kimplas Piping Systems Ltd, Nashik  | REPRESENTATIVE   |
| Mahanagar Telephone Nigam Limited, New Delhi  | SUPERINTENDING ENGINEER (CIVIL)<br>SHRI M. K. SINGHAL ( <i>Alternate</i> )                                   |
| National Test House, Kolkata  | SHRI D. SARKAR<br>DR NISHI SRIVASTAVA ( <i>Alternate</i> )   |
| Optiflux Pipe Industries, Jodhpur   | SHRI PRAVEEN PARIHAR<br>SHRI AMIT BORANA ( <i>Alternate</i> )  |
| Reliance Industries Limited, Mumbai   | SHRI S. V. RAJU<br>SHRIMATI ARUNA KUMARI ( <i>Alternate I</i> )<br>SHRI JAYESH DESAI ( <i>Alternate II</i> ) |
| Rex Polyextrusion Limited, Sangli   | SHRI SHASHANK PARGAONKAR<br>SHRI C. B. DANDEKAR ( <i>Alternate</i> )   |
| RITES Limited, New Delhi  | SHRI PANKAJ AGGARWAL<br>SHRI MUKESH SINHA ( <i>Alternate</i> )   |
| Rural Water Supply & Sanitation Department, Govt of Orissa, Bhubaneswar               | CHIEF ENGINEER   |
| Supreme Industries Limited, Jalgaon   | SHRI G. K. SAXENA<br>SHRI P. L. BAJAJ ( <i>Alternate</i> )   |

| <i>Organization</i>   | <i>Representative(s)</i>  |
|---|---|
| Tamil Nadu Water Supply & Drainage Board,<br>Chennai                | ENGINEERING DIRECTOR<br>JOINT CHIEF ENGINEER (COM) ( <i>Alternate</i> ) |
| In Personal Capacity ( <i>A-59, Sector 35, Noida -<br/>201301</i> ) | SHRI KANWAR A. SINGH  |

Composition of the Working Group for UPVC Column Pipes, CED 50/WG2

| <i>Organization</i>   | <i>Representative(s)</i>   |
|---|--|
| Central Institute of Plastic Engineering and<br>Technology, Chennai | SHRI M. NAVANEETHAN ( <i>Coordinator</i> )                           |
| Ashirvad Pipes Pvt Ltd, Bengaluru                                   | SHRI MOHAMMAD NOUFAL<br>SHRIMATI SWATI SARALAYA ( <i>Alternate</i> ) |
| Astral Polytechnik Ltd, Ahmedabad                                   | SHRI RITESH PATEL  |
| Duke Pipes Pvt Ltd, Palanpur  | SHRI GIRISH A. PATEL   |
| Finolex Industries Ltd, Pune  | SHRI D. J. SALUNKE<br>SHRI CHUNILAL PARVANI ( <i>Alternate</i> )     |
| Jain Irrigation System Ltd, Jalgaon                                 | SHRI M. R. KHARUL  |
| Supreme Industries Ltd, Jalgaon                                     | SHRI G. K. SAXENA<br>SHRI ANUP MANDAL ( <i>Alternate</i> )           |
| In Personal Capacity ( <i>Church Lane, Balasore -<br/>756001</i> )  | SHRI SANJAY KUMAR MOHAPATRA  |
| In Personal Capacity ( <i>A-59, Sector 35, Noida -<br/>201301</i> ) | SHRI KANWAR A. SINGH   |



## Bureau of Indian Standards

BIS is a statutory institution established under the *Bureau of Indian Standards Act, 2016* to promote harmonious development of the activities of standardization, marking and quality certification of goods and attending to connected matters in the country.

### Copyright

BIS has the copyright of all its publications. No part of these publications may be reproduced in any form without the prior permission in writing of BIS. This does not preclude the free use, in the course of implementing the standard, of necessary details, such as symbols and sizes, type or grade designations. Enquiries relating to copyright be addressed to the Head (Publication & Sales), BIS.

### Review of Indian Standards

Amendments are issued to standards as the need arises on the basis of comments. Standards are also reviewed periodically; a standard along with amendments is reaffirmed when such review indicates that no changes are needed; if the review indicates that changes are needed, it is taken up for revision. Users of Indian Standards should ascertain that they are in possession of the latest amendments or edition by referring to the website-[www.bis.gov.in](http://www.bis.gov.in) or [www.standardsbis.in](http://www.standardsbis.in).

This Indian Standard has been developed from Doc No.: CED 50 (15770).

### Amendments Issued Since Publication

| Amend No. | Date of Issue | Text Affected |
|-----------|---------------|---------------|
|           |               |               |
|           |               |               |
|           |               |               |
|           |               |               |

## BUREAU OF INDIAN STANDARDS

### Headquarters:

Manak Bhavan, 9 Bahadur Shah Zafar Marg, New Delhi 110002

Telephones: 2323 0131, 2323 3375, 2323 9402

Website: [www.bis.gov.in](http://www.bis.gov.in)

### Regional Offices:

|   | Telephones               |
|---|--------------------------|
| Central : 601/A, Konnectus Tower -1, 6 <sup>th</sup> Floor,<br>DMRC Building, Bhavbhuti Marg, New<br>Delhi 110002 | { 2323 7617              |
| Eastern : 8 <sup>th</sup> Floor, Plot No 7/7 & 7/8, CP Block, Sector V,<br>Salt Lake, Kolkata, West Bengal 700091 | { 2367 0012<br>2320 9474 |
| Northern : Plot No. 4-A, Sector 27-B, Madhya Marg,<br>Chandigarh 160019   | { 265 9930               |
| Southern : C.I.T. Campus, IV Cross Road, Taramani, Chennai 600113   | { 2254 1442<br>2254 1216 |
| Western : Plot No. E-9, Road No.-8, MIDC, Andheri<br>(East), Mumbai 400093  | { 2821 8093              |

**Branches :** AHMEDABAD. BENGALURU. BHOPAL. BHUBANESHWAR. CHANDIGARH. CHENNAI. COIMBATORE. DEHRADUN. DELHI. FARIDABAD. GHAZIABAD. GUWAHATI. HIMACHAL PRADESH. HUBLI. HYDERABAD. JAIPUR. JAMMU & KASHMIR. JAMSHEDPUR. KOCHI. KOLKATA. LUCKNOW. MADURAI. MUMBAI. NAGPUR. NOIDA. PANIPAT. PATNA. PUNE. RAIPUR. RAJKOT. SURAT. VISAKHAPATNAM.