

साइकिल, स्केटबोर्ड और रोलर स्केट्स के
उपयोगकर्ताओं के लिए संरक्षी हेलमेट —
विशिष्टि

Protective Helmet for Users of
Bicycles, Skateboards and Roller
Skates — Specification

ICS 13.340.20

© BIS 2024



भारतीय मानक ब्यूरो
BUREAU OF INDIAN STANDARDS
मानक भवन, 9 बहादुर शाह ज़फर मार्ग, नई दिल्ली - 110002
MANAK BHAVAN, 9 BAHADUR SHAH ZAFAR MARG
NEW DELHI - 110002

www.bis.gov.in www.standardsbis.in

FOREWORD

This Indian Standard was adopted by the Bureau of Indian Standards, after the draft finalized by the Fire Fighting Sectional Committee had been approved by the Civil Engineering Division Council.

Helmet is one of the most important items of personal protective equipment used by the users of bicycle, skateboards, and roller skates for protection against the hazards connected. This standard has been framed to cover provisions of protective helmets for everyday use by the bicycle riders and for other recreational activities.

A proportion of the energy of an impact is absorbed by the helmet, thereby reducing the force of the blow sustained by the head. The structure of the helmet may be damaged in absorbing this energy and any helmet that sustains a severe blow needs to be replaced even if damage is not apparent.

Wearing a helmet cannot always prevent death or permanent disability because the level of protection it provides depends on the specifics of the accident.

It is of importance for the wearer's comfort and psychrometric performance that a helmet is ventilated. Manufacturers of helmets are urged to design their helmets to encourage a flow of air over the wearer's head.

IS 4151 : 2015 'Protective helmet for two wheeler riders — Specification (*fourth revision*)' provides the requirements for the protective helmets with or without lower face cover for everyday use by two-wheeler riders. The standard IS 4151 provides apart from others two prominent sizes of the headforms namely 500 and 520 which suits the children.

The helmets, having headform size below 500, conforming to this standard may be used as 'crash helmet' for the children particularly below the age of 4 years while they are riding on pillion of two-wheeler, wherein speed shall not exceed 40 km/h. This standard is thus formulated to address the Gazette Notification dated 15 February 2022 issued by the Ministry of Road Transport and Highways (MoRTH) on the above subject. Considering the usability, the Committee observed that the mass of crash helmets which conform to this standard be as low as possible.

Bicycle riders' helmets and helmets for users of skateboards and roller skates are fitted with a retention system to retain the helmet on the head. However, there may be a foreseeable risk that helmets of young children could become trapped and thereby cause a risk of strangulation of the child. In such cases an impact protection helmet for young children shall be used under expert guidance.

In the formulation of this standard considerable assistance was taken from the:

EN 1078 : 2012 'Helmets for pedal cyclists and for users of skateboards and roller skates'.

This standard contributes to the United Nations 'Sustainable Development Goal 3, SDG 3: 'Good Health and Wellbeing'.

The composition of the Committee responsible for the formulation of this standard is given in [Annex B](#).

For the purpose of deciding whether a particular requirement of this standard is complied with the final value, observed or calculated, expressing the result of a test or analysis shall be rounded off in accordance with IS 2 : 2022 'Rules for rounding off numerical values (*second revision*)'. The number of significant places retained in the rounded off value should be same as that of the specified value in this standard.

Indian Standard

PROTECTIVE HELMET FOR USERS OF BICYCLES, SKATEBOARDS AND ROLLER SKATES — SPECIFICATION

1 SCOPE

1.1 This standard covers the requirements regarding the material, construction, workmanship, finish, mass, and performance for helmets worn by the users of bicycles, skateboards, and roller skates.

1.2 The helmets covered in this standard can also be used when children are accompanied by adult while traveling on motorcycle at speeds not exceeding 40 km/h.

1.3 This standard covers the requirements and corresponding methods of test as follows:

- a) Construction, including field of vision;
- b) Shock absorbing properties;
- c) Retention system properties, including chin strap and fastening devices; and
- d) Marking information.

2 REFERENCES

The standards given below contain provisions which through reference in this text, constitute provisions of this standard. At the time of publication, the editions indicated were valid. All standards are subject to revision and parties to agreements based on this standard are encouraged to investigate the possibility of applying the most recent edition of these standards:

<i>IS No.</i>	<i>Title</i>
 692 : 1993	Headforms for testing of helmets — Specification (first revision)
IS 17863	Plastics — Methods of exposure to laboratory light sources
(Part 1) : 2022/ ISO 4892-1 : 2016	General guidance
(Part 2) : 2022/ ISO 4892-2 : 2013	Xenon-arc lamps
(Part 3) : 2022/ ISO 4892-3 : 2016	Fluorescent UV lamps

3 TERMINOLOGY

For the purposes of this document, the following terms and definitions apply:

3.1 Basic Plane of the Human Head — A plane at the level of the external ear opening (external auditory meatus) and the lower edge of the eye sockets (orbits).

3.2 Basic Plane of a Headform — A plane relative to the headform that corresponds to the basic plane of the human head.

3.3 Chin-Strap — A part of the retention system consisting of a strap that passes under the wearer's jaw to keep the helmet in position.

3.4 Helmet Type — Category of helmets which does not differ in such essential respects as the materials or dimensions or construction of the helmet, of the retention system or of the protective padding.

3.5 Padding

3.5.1 Protective Padding — A material used to absorb impact energy.

3.5.2 Comfort Padding — A lining material provided for the wearer's comfort.

3.5.3 Sizing Padding — A lining material used to adjust the size of helmet.

3.6 Protective Helmet (Crash Helmet) — Item that is worn on the head and is designed to absorb impact energy to lessen the risk of head injury and brain damage.

3.7 Reference Plane — A construction plane parallel to the basic plane of the headform at a distance from it which is a function of the size of the headform.

3.8 Retention System — The complete assembly by means of which the helmet is maintained in position on the head including any devices for adjustment of the system or to enhance the wearer's comfort.

3.9 Test Area — Area of the helmet in which impact tests may be conducted which corresponds to the minimum protected area of the human head.

To access Indian Standards click on the link below:

https://www.services.bis.gov.in/php/BIS_2.0/bisconnect/knownyourstandards/Indian_standards/isdetails/

4 REQUIREMENTS

4.1 Materials

For those parts of the helmet coming into contact with the skin, the material shall be known not to undergo considerable change from contact with sweat or with compounds expected to be found in toiletries. Materials that are known to cause skin conditions shall not be used.

4.2 Construction

The typical helmet has a way of absorbing impact force and a way of keeping the helmet on the head during an accident.

The helmet should be durable and withstand handling. The helmet shall be so designed and shaped that the parts of it (visor, rivets, ventilators, edges, fastening device and the like) are not likely to injure the user in normal use.

NOTE — Helmets should:

- a) have low weight;
- b) be ventilating;
- c) be easy to put on and take off;
- d) be usable with spectacles; and
- e) not significantly interfere with the ability of the user to hear traffic noise.

4.3 Field of Vision

When tested in accordance with [5.7](#) there shall be no occultation in the field of vision bounded by angles as follows (see [Fig. 1](#)), (see also IS 7692):

- a) Horizontally — *Min* 105° from the longitudinal vertical median plane to the left- and right-hand sides;
- b) Upwards — *Min* 25° from the reference plane; and
- c) Downwards — *Min* 45° from the basic plane.

4.4 Shock Absorbing Capacity

The helmet shall give protection to the forehead, rear, sides, temples, and crown of the head. When tested in accordance with [5.3](#) and [5.4](#), the peak acceleration shall not, for each impact, exceed 250 g for the velocity of $5.42 \frac{+0.1}{-0}$ m/s on the flat anvil, and $4.57 \frac{+0.1}{-0}$ m/s on the kerbstone anvil.

NOTE — These are theoretically equivalent to 1 497 mm and 1 064 mm drop heights, respectively.

4.5 Durability

After testing, the helmet shall not have any damage that could seriously hurt the wearer (sharp edges, points).

4.6 Retention System

4.6.1 General

Means shall be provided for retaining the helmet on the wearer's head. All parts of the retention system shall be securely attached to the helmet.

4.6.2 Chin Strap

The chin strap shall not include a chin cup. Any chin strap shall be no less than 15 mm wide. Chin straps may be fitted with means of enhancing comfort for the wearer.

4.6.3 Fastening Device

Any retention system shall be fitted with a device to adjust and maintain tension in the system. The device shall be capable of adjustment so that the buckle does not sit on the jawbone.

4.6.4 Colour

No part of the retention system shall be coloured green.

NOTE — It is recommended that the opening mechanism be marked with red or orange colour.

4.6.5 Strength

When tested in accordance with [5.5](#), the dynamic extension of the retention system shall not exceed 35 mm and the residual extension shall not exceed 25 mm. For this purpose, extension includes slippage of the fastening device.

Damage to the retention system shall be accepted provided that the above requirements are met.

NOTE — In this test, slippage of the fastening device can be measured and recorded separately from other contributions to the extension, but this is for information only and is not subject to a separate requirement.

4.6.6 Effectiveness

When tested in accordance with [5.6](#) the helmet shall not come off the headform.

4.6.7 Ease of Release

Following the strength test in accordance with [5.5](#) and with the load still applied, it shall be possible to open the release system with one hand.

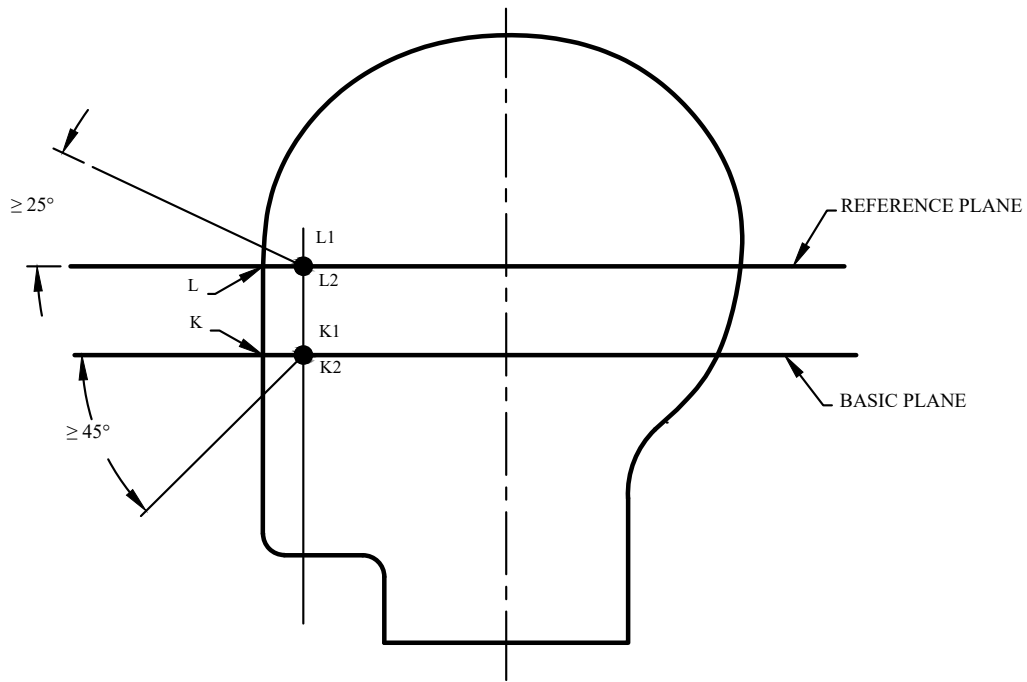

1A SECTION OF HEADFORM IN LONGITUDINAL VERTICAL PLANE

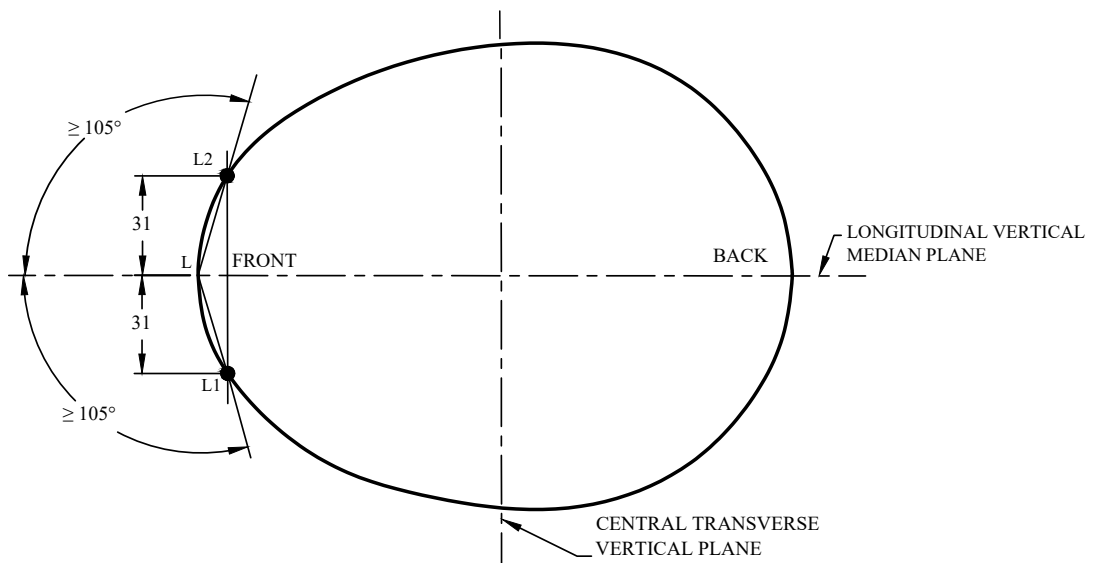

1B SECTION OF HEADFORM IN REFERENCE PLANE

NOTES

- 1 Longitudinal vertical median plane (see 2.12 of IS 7692).
- 2 Central transverse vertical plane (see 2.13 of IS 7692).

All dimensions in millimetres.

FIG. 1 FIELD OF VISIONS

5 TESTING

5.1 Headforms

The headforms used shall comply with IS 7692. The sizes in [Table 1](#) shall be used, except for determination of shock absorbing capacity, for which only size designations 495, 535, 575, 605 and 625 shall be used.

For determination of retention system strength and ease of release, the headforms used shall comply with IS 7692 at least down from the basic plane.

Table 1 Sizes of Headforms

(Clause [5.1](#))

SI No.	Size Designation	Inside Circumference of Helmet mm
(1)	(2)	(3)
i)	455	460
ii)	465	470
iii)	475	480
iv)	485	490
v)	495 (A)	500
vi)	515 (C)	520
vii)	535 (E)	540
viii)	555 (G)	560
ix)	575 (J)	570
x)	585 (K)	580
xi)	605 (M)	600
xii)	625 (O)	620

5.2 Inspection and Determination of Mass

Inspect the helmet to ascertain whether it is suitable for its intended purpose and fulfils the general requirements in [4.2](#). Determine the mass of the helmets of the same size submitted for testing. Calculate and record the mean value in g rounded off to the nearest 10 g, stating the size of the helmet.

5.3 Number of Samples and Sequence of Tests

For each helmet type, four helmets for each headform size that fits within the manufacturers' claimed head size range shall be submitted for testing.

The sequence of tests performed on each helmet size and the tests performed on the same sample are given in [Table 2](#).

The fourth sample is reserved as a reference sample, which can be used by the test laboratory in case of doubt about any of the performance requirements.

5.4 Determination of Shock Absorbing Capacity

5.4.1 Test Area

- Take a headform of appropriate size designation and mark a point B, midway between point A' (the point where the AA' plane, as defined in IS 7692, exits the back of the headform) and point F (see [Fig. 1](#) and [Fig. 2](#)).
- Place the helmet on the headform. Apply a vertical load of 50 N on the crown of the helmet in order to stabilize the helmet on the headform. Position the front edge of the helmet to meet the upwards field of vision specified in [4.3](#) or to the manufacturer's normal wearing position if this is detailed by the manufacturer and results in greater than the specified upwards vision.
- Draw the AA'' line (in the AA' plane) on the helmet.
- Draw a line on the helmet, parallel to and approximately 20 mm above the AA'' line (for use as an angular measurement datum line).
- Mark the helmet at points B₁ and B₂. These points are the sideways horizontal projection of point B on to the outer surface of the helmet.
- Draw a line RR' on the helmet passing through B₁ and B₂, the line being angled 10° upwards toward the front of the helmet relative to the datum line drawn in (d).

The area above the line drawn in (f) is the test area for impacts on to the flat anvil. The area above the line RWA'' is the test area for impacts on to the kerbstone anvil, point W being the intersection of the lines marked in accordance with (c) and (f) above.

5.4.2 Conditioning

5.4.2.1 High temperature conditioning

The helmet shall be exposed to a temperature of 50 °C ± 2 °C for not less than 4 h and not more than 6 h.

5.4.2.2 Low temperature conditioning

The helmet shall be exposed to a temperature of -20 °C ± 2 °C for not less than 4 h and not more than 6 h.

5.4.2.3 Artificial ageing

The outer surface of the protective helmet shall be exposed successively to:

- a) Ultraviolet irradiation by a 125 W xenon-filled quartz lamp for 48 h at a range of 250 mm;
- b) Spraying for 4 h to 6 h with water at ambient temperature at the rate of 1 l/min.

NOTE — A method for artificial ageing is described in Annex A. This method may be used as an alternative to the conditioning according to 5.4.2.3.

5.4.3 Apparatus

5.4.3.1 Description

The test apparatus shall comprise:

- a) an anvil rigidly fixed to a base;
- b) a free fall guidance system;

- c) a mobile system supporting the helmeted headform;
- d) a metal headform fitted with a tri-directional accelerometer;
- e) an accelerometer output recording and conditioning system; and
- f) a system by which the point of impact can be brought into correspondence with the centre of the anvil.

The principle is shown in Fig. 3.

5.4.3.2 Base

The base shall be monolithic and made of steel or concrete or a combination of these materials and have a mass of at least 500 kg. No part of the base or anvil shall have a resonant frequency liable to affect the measurements.

Table 2 Sequence of Test and Tests Per Sample

(Clause 5.3)

SI No.	Performance Test	Sequence of Test	Sample Number		
			(4)	(5)	(6)
(1)	(2)	(3)	(4)	(5)	(6)
i)	Retention system effectiveness (5.6)	First	1	–	–
ii)	Shock absorbing capacity (5.4)	Second	1	2	3
iii)	Retention system strength (5.5)	Third	–	2	3

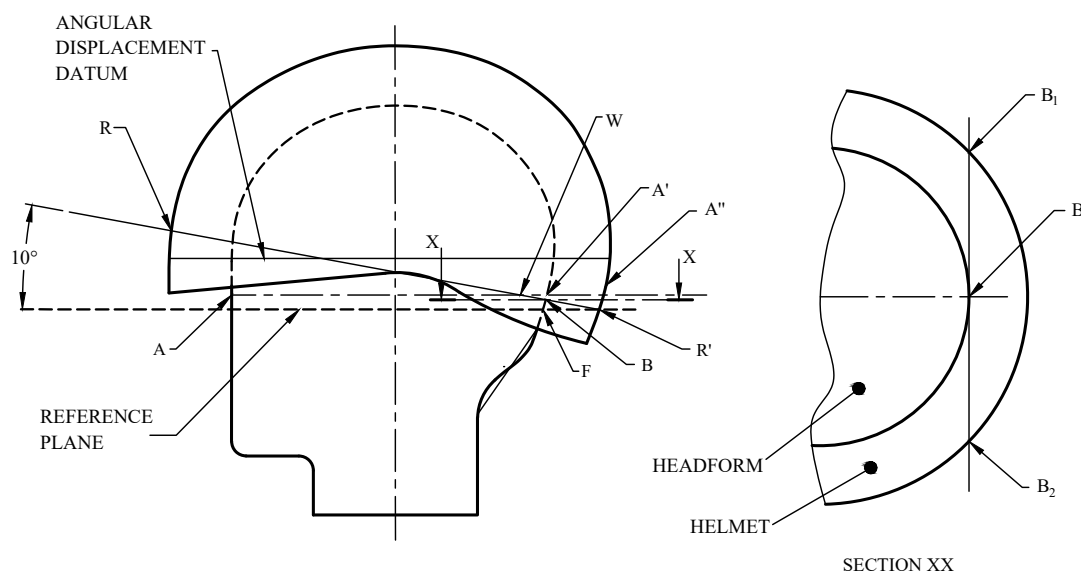

FIG. 2 DEFINITION OF TEST AREA

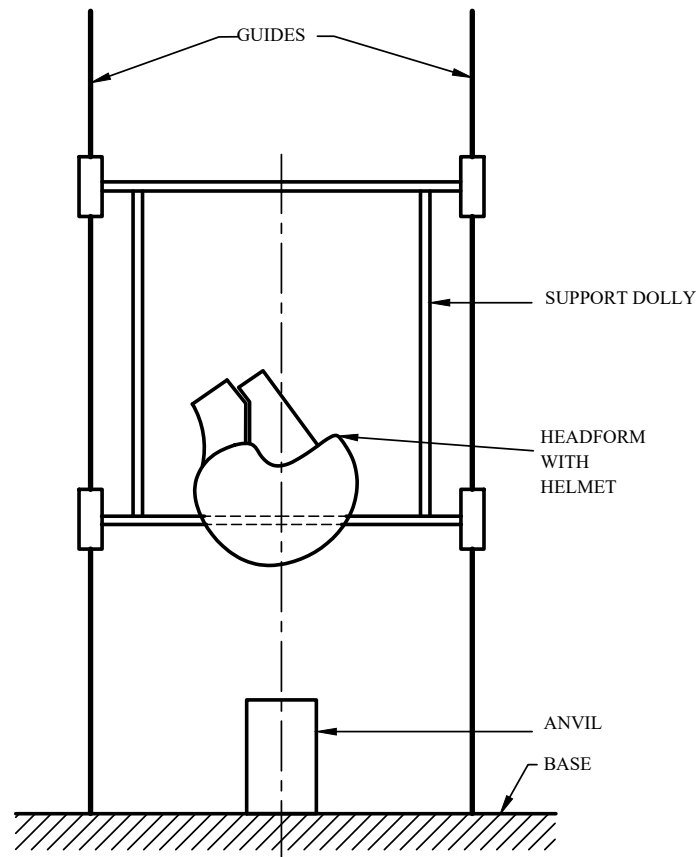

FIG. 3 PRINCIPLE OF APPARATUS FOR DETERMINATION OF SHOCK ABSORBING CAPACITY

5.4.3.3 Anvil

A flat steel anvil having a circular impact face of $130 \text{ mm} \pm 3 \text{ mm}$ diameter. A steel anvil simulating a kerbstone and having two faces each inclined at $52.5^\circ \pm 2.5^\circ$ to the vertical and meeting along a striking edge with a radius of $15 \text{ mm} \pm 0.5 \text{ mm}$. The height shall not be less than 50 mm and the length not less than 125 mm.

5.4.3.4 Mobile system and guides

The mobile system supporting the headform shall be such that its characteristics do not affect the measurement of acceleration at the centre of gravity of the headform. It shall also be such that any point in the test area can be positioned vertically above the centre of the anvil.

5.4.3.5 Accelerometer and measuring assembly

The tri-directional accelerometer shall be capable of measuring and recording accelerations up to 2 000 g and its maximum mass shall be 50 g.

The measuring system, including the drop assembly, shall have a frequency response in accordance with channel frequency class (CFC) 1 000 (see ISO 6487).

The measuring system shall include equipment to record the velocity of the headform.

5.4.3.6 Headforms

The headforms to be used shall comply with IS 7692 (see 5.1).

5.4.4 Procedure

The testing for shock absorption capacity shall be carried out in accordance with Table 3.

Make the first impact within 1 min and all further impacts within 3 min from removal of the helmet from the conditioning chamber.

Impact the helmets on sites selected by the test laboratory to present worst case conditions. Use the kerbstone anvil without any restriction on its orientation. In each series of tests on a model, conduct impacts on each perceived weak area (that is, ventilation features, retention anchorages or webbing supports) which fall within the test area. The impact sites on each sample shall be separated by a minimum distance of 150 mm along the chord. The impact site shall be centred over the centre of the anvil.

Table 3 Test Parameters

(Clause 5.4.4)

Sl No.	Sample Number	Conditioning	Anvil
(1)	(2)	(3)	(4)
i)	1	High temperature	Kerbstone
		No reconditioning	Flat
ii)	2	Low temperature	Flat
		No reconditioning	Kerbstone
iii)	3	Artificial ageing	Kerbstone
		No reconditioning	Flat

The headform shall never be turned so that the vertical axis comes below the horizontal plane even if the test area allows (see Fig. 3).

In the event of there being no helmet material at the impact site, then the adjacent material shall manage the energy of such an impact. In the case where anvil/headform contact can be made at the setting up stage for an impact, the result shall be deemed a failure, without conducting the test.

Measure the velocity of the helmeted headform at a distance not exceeding 60 mm prior to impact to an accuracy of 1 percent.

5.5 Determination of Retention System Strength and Ease of Release

5.5.1 Apparatus

5.5.1.1 Description

The test apparatus shall comprise:

- a means to hold the helmet with headform and loads;
- a headform equipped with a loading device comprising a guide, an arrest device, and a drop weight; and
- a retention system extension measuring system.

A suitable apparatus is shown in Fig. 4.

5.5.1.2 Headform

The headform to be used shall comply, at least down to the basic plane, with IS 7692 (see 5.1).

5.5.1.3 Loadbearing device

The load bearing device shall consist of a chin strap stirrup with a round or square guide bar. The bar shall have a steel end stop. The chin strap stirrup shall consist of two metal bars each with a diameter

of 12.5 mm \pm 0.5 mm that have a centre distance of 76 mm \pm 1 mm. The guide bar shall be provided with a cylindrical weight having a mass of 4 kg \pm 0.2 kg and allow for a drop of the weight of 600 mm \pm 5 mm. The mass of the entire loading apparatus excluding the 4 kg weight shall be 5 kg \pm 0.5 kg.

5.5.1.4 Measuring device

A device to measure the vertical displacement of the chin strap fixture shall be included.

5.5.1.5 Procedure

Place the helmet on the headform. Fasten the chin strap under the stirrup bars so that the entire test apparatus hangs freely on the retention system. Place a preload ballast of 5 kg \pm 0.5 kg on the helmet. Then raise the drop weight and allow it to fall and impact the end stop. During the test, measure the dynamic displacement of the chin strap stirrup. After 2 min, measure the residual displacement with the drop weight still on the end stop. Ascertain whether or not the system can be released by one hand.

5.6 Determination of Retention System Effectiveness

5.6.1 Apparatus

The apparatus shall comprise:

- a drop weight with a mass of 10.0 kg \pm 0.1 kg;
- a guiding system with a total mass of 3.0 kg \pm 0.1 kg allowing the drop weight to drop in a guided free fall;
- a flexible strap and a hook attached to the guiding system running over a pulley with a diameter of 100 mm. The extension of the strap shall be less than 18 mm/m under a load of 1 000 N;

- d) headforms according to IS 7692 (see 5.1); and
- e) a base to hold the headforms.

Fig. 5 shows the principle of the apparatus.

5.6.2 Procedure

Fit the helmet according to the manufacturer’s instructions to the appropriate headform which shall be the smallest and the largest and intermediate sizes measured for the helmet type.

Adjust the retention system to be as tight as possible. Hook the strap to the rear of the helmet.

Release the drop weight and allow it to fall through a distance of 175 mm ± 5 mm. Observe whether or

not the helmet comes off.

5.7 Determination of Field of Vision

To carry out the test, the test laboratory shall select the size it considers likely to yield the least favourable result for the helmet type.

Place the helmet on a headform of appropriate size. Apply a load of 50 N on the crown of the helmet in order to stabilize the helmet on the headform. Ascertain that the vertical median plane of the helmet coincides with the vertical median plane of the headform.

Adjust the helmet on the headform according to the manufacturer’s instructions, if supplied. In that position, determine if the helmet complies with the requirements for field of vision in 4.3.

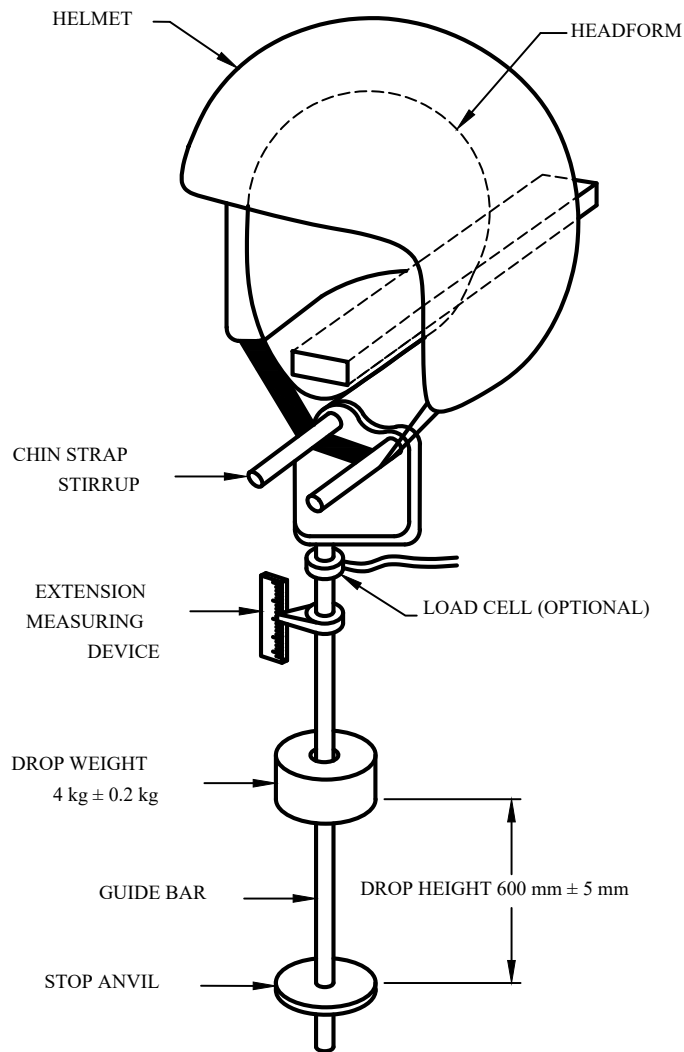
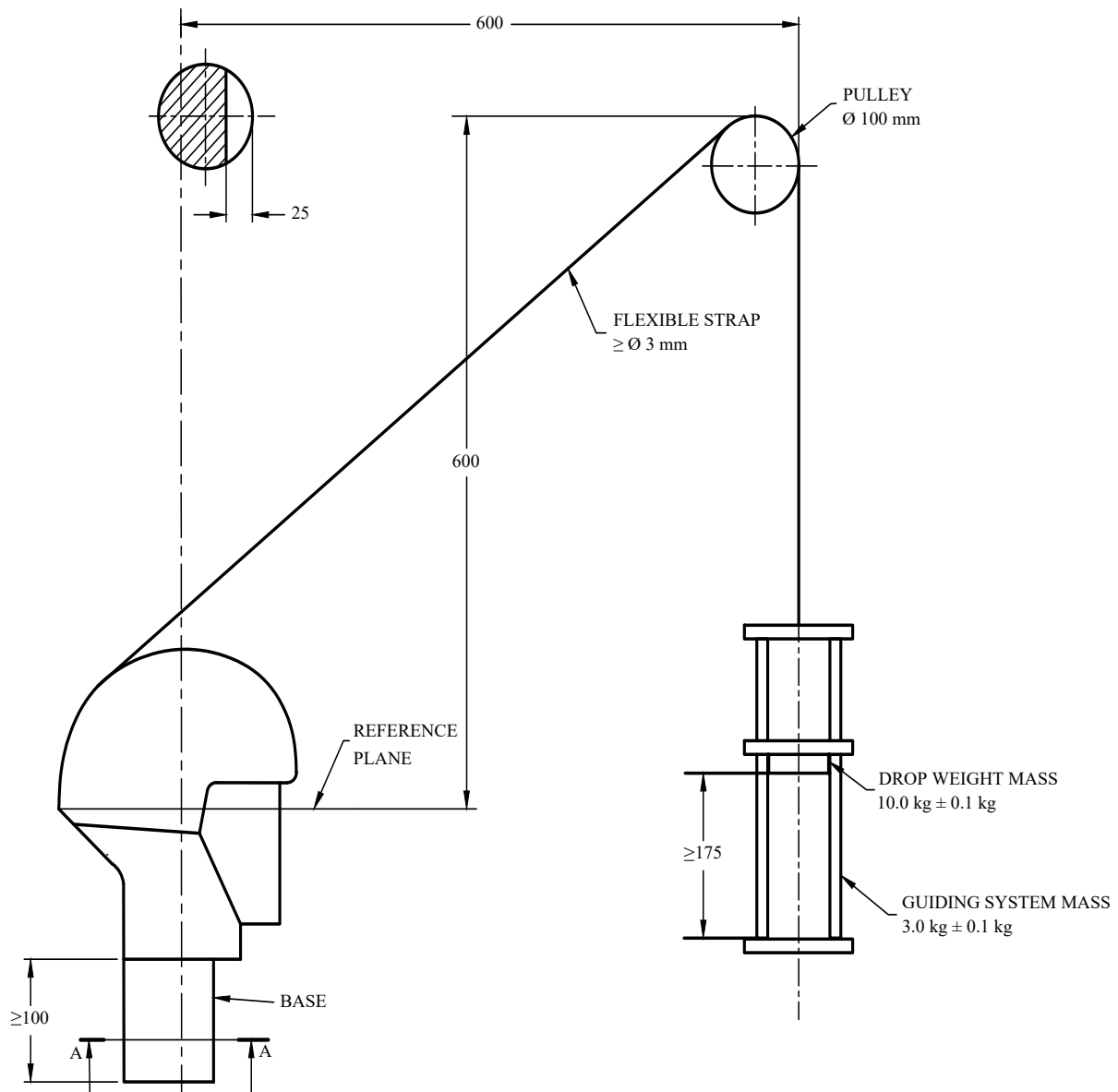

FIG. 4 EXAMPLE OF AN APPARATUS FOR TESTING OF RETENTION SYSTEM STRENGTH



All dimensions in millimetres.

FIG. 5 APPARATUS FOR TESTING OF THE RETENTION SYSTEM EFFECTIVENESS

5.8 Test Report

The test report shall contain at least the following information:

- Identification details of the helmets including range of sizes;
- Results of the test in accordance with 5.2 to 5.7;
- Date of testing; and
- Name of the test laboratory.

6 MARKING

6.1 Each helmet shall be marked in such a way that the following information is easily legible by the

user and is likely to remain legible throughout the life of the helmet:

- Name or trademark of the manufacturer;
- Designation of the model;
- Designation, which shall be one or more of the following: helmet for pedal cyclists, skateboards, or roller skaters;
- Size or size range of the helmet, quoted as the circumference (in centimetres) of the head which the helmet is intended to fit;
- Weight of the helmet (the average mass in grams determined according to 5.2);
- Year and month of manufacture;

g) Following text:

“**WARNING** — This helmet should not be used by children while climbing or doing other activities when there is a risk of strangulation/hanging if the child gets trapped with the helmet.”

6.2 In addition, if the helmet has components made of material which are known to be adversely affected by contact with hydrocarbons, cleaning fluids, paints, transfers or other extraneous additions, the helmet shall carry an appropriate warning.

6.3 If there is a consumer sales packaging, the information specified in (a), (c) and (g) shall also be given on that package. The text shall be of minimum font size 12.

6.2 Information to be Supplied by the Manufacturer

With every packing to the helmet, the following clear information, preferably in English and local language, shall be given:

- a) That the helmet can only protect if it fits well, and that the buyer should try different sizes and choose the size which feels secure and comfortable on the head;
- b) That the helmet should be adjusted to fit the user, for example, the straps positioned so that they do not cover the ears, the

buckle positioned away from the jawbone and the straps and buckle adjusted to be both comfortable and firm;

- c) How the helmet should be positioned on the head to ensure the intended protection is provided (for example, that it should be placed so as to protect the forehead and not be pushed too far over the back of the head);
- d) That a helmet cannot always protect against injury;
- e) That a helmet subjected to a severe impact should be discarded and destroyed; and
- f) A statement of the danger of modifying or removing any of the original component parts of the helmet other than as recommended by the manufacturer, and that helmets should not be adapted for the purpose of fitting accessories in a way not recommended by the manufacturer.

6.3 BIS Certification Marking

The product(s) conforming to the requirements of this standard may be certified as per the conformity assessment schemes under the provisions of the *Bureau of Indian Standards Act, 2016* and the Rules and Regulations framed thereunder, and the product may be marked with the Standard Mark.

ANNEX A

[Clause 5.4.2.3, SI No. (b) (Note)]

ALTERNATIVE PROCEDURE FOR ARTIFICIAL AGEING

A-1 The helmet submitted to artificial ageing should be exposed to the radiation of a xenon arc lamp. The radiant energy of the lamp should be filtered to provide a spectral power distribution that closely approximates that of terrestrial daylight.

The helmet should be fixed on a cylindrical holder concentric to the lamp and which rotates at a speed of 1/min to 5/min around its axis.

Each helmet which will subsequently be tested for shock absorption should be orientated so that the area of test should be directed towards the lamp. The plane tangential to the shell at this point should be normal to a radius of the cylindrical holder.

The radiant energy incident in the plane of the test areas should be either measured or calculated from information provided by the manufacturer of the test apparatus. The exposure interval should be adjusted so that the exposed samples should receive a total energy of 1 GJ/m² over the wavelength range 280 nm to 800 nm.

The samples should be sprayed with distilled or demineralized water (having a conductivity below 5 µS/cm) intermittently with a cycle of 18 min

spraying and 102 min without spraying. During the latter periods, the measured relative humidity should be 50 percent ± 5 percent.

The temperature within the test chamber should be measured with a black standard thermometer placed at the same distance from the lamp as the exposed test areas of the helmets. The temperature should be maintained at 70 °C ± 3 °C.

All other test and calibration conditions for the apparatus should be in accordance with Method A of IS 17863 (Part 1), IS 17863 (Part 2) and IS 17863 (Part 3).

NOTES

1 Not all available test apparatus, otherwise meeting the requirements of IS 17863 (Part 1), IS 17863 (Part 2), and IS 17863 (Part 3), will incorporate sample holder frames of diameter sufficient to accommodate complete helmets.

2 The position of the water sprays may require adjustment in order to avoid interference with the test samples.

3 The energy output of the xenon arc should be capable of being reduced below normal operational levels so as to maintain acceptable intensities in the sample surface plane required by this procedure.

ANNEX B

(Foreword)

COMMITTEE COMPOSITION

Fire Fighting Sectional Committee, CED 22

<i>Organization</i>	<i>Representative(s)</i>
In Personal Capacity (<i>House No. 1933, Sector-4, Urban Estate, Gurugram</i>)	DR K. C WADHWA (Chairperson)
Advance Firetec and Research Lab Private Limited, New Delhi	SHRI SUBIR K. NANDI
Agni Controls, Chennai	SHRI D. BALACHANDRAN SHRI ARUN KUMAR BALACHANDRAN (<i>Alternate</i>)
Airports Authority of India, New Delhi	SHRI ARVIND KUMAR SHRI P. K. DESHMUKH (<i>Alternate</i>)
Central Industrial Security Force, New Delhi	SHRI SUDHIR KUMAR
Central Public Works Department, New Delhi	SHRI CHAITANYA KUMAR VERMA SHRI PREM MOHAN (<i>Alternate</i>)
Centre for Fire and Explosive Environment Safety, Defence Institute of Fire Research, Delhi	SHRI PANKAJ CHAWLA
CSIR - Central Building Research Institute, Roorkee	DR HARPAL SINGH SHRI SHORAB JAIN (<i>Alternate</i>)
Directorate General of Quality Assurance, New Delhi	CONTROLLER JT CONTROLLER (<i>Alternate</i>)
Engineers India Limited, New Delhi	SHRI AMITABH KISHORE SHRI GYASUDDIN (<i>Alternate I</i>) SHRI AKASH DEEP PATEL (<i>Alternate II</i>)
Fire and Emergency Services, Kolkata	SHRI ABHIJIT PANDEY SHRI KAMAL NANDY (<i>Alternate</i>)
Fire and Security Association of India, Chennai	SHRI ANAS RIZVI
F. M. Engineering International India Branch, Bengaluru	SHRI SRIKANTH YAJJALA SHRI YASSAR NABEEL MOHAMED (<i>Alternate</i>)
Gunnebo India Private Limited, Thane	SHRI JOHNSON MATHEW SHRI SAMIR MISRI (<i>Alternate I</i>) SHRI YOGESH JADHAV (<i>Alternate II</i>)
H. D. Fire Protect Private Limited, Thane	SHRI HARISH N. DHARAMSHI SHRI K. T. CHAUDHARI (<i>Alternate I</i>) SHRI ANIK N. DHARAMSHI (<i>Alternate II</i>)
Indian Oil Corporation Limited, New Delhi	SHRI SAMIR V. SATHE
Institute of Fire Engineers India, New Delhi	PRESIDENT SHRI U. S. CHHILLAR (<i>Alternate I</i>) SHRI PRADEEP KUMAR (<i>Alternate II</i>)
Johnson Controls, Bengaluru	SHRI SANTHOSH MUZUMDAR SHRI NITIN RASTOGI (<i>Alternate</i>)

<i>Organization</i>	<i>Representative(s)</i>
K. V. Fire Chemicals India Private Limited, Navi Mumbai	SHRI RAJESH SABADRA SHRI UDAY K. SHROFF (<i>Alternate</i>)
Maharashtra Fire Services, Mumbai	SHRI SANTOSH S. WARICK SHRI KIRAN HATYAL (<i>Alternate</i>)
Ministry of Home Affairs, New Delhi	SHRI PRASHANT LONKAR SHRI MORESHWAR KUDKILWAR (<i>Alternate</i>)
National Association of Fire Officers, Mumbai	SHRI M. V. DESHMUKH PRESIDENT (<i>Alternate</i>)
Nohmi Bosai India Private Limited, Gurugram	SHRI ISWAR IYER SHRI NEERAJ SEHGAL (<i>Alternate</i>)
Oil Industry Safety Directorate, Noida	SHRI MURARI MOHAN PRASAD SHRI N. K. PANDEY (<i>Alternate</i>)
Proion Consultants, New Delhi	SHRI SANDEEP GOEL
Reliance India Limited, Mumbai	SHRI UMESH KHANDALKAR SHRI MUKESH CHANDRA KUMAR (<i>Alternate</i>)
RESQ Technologies, Aabad	SHRI ROHIT V. SHAH
Safex Fire Services Limited, Mumbai	SHRI JITENDRA SHAH SHRI SANDIP SHAH (<i>Alternate</i>)
Shah Bhogilal Jethalal & Bros., Ahmedabad	SHRI MUKESH M. SHAH
State Bank of India, Mumbai	SHRI MAYANK YADAV
Swastik Synergy Engineering Private Limited, Mumbai	SHRI MUKESH D. SHAH SHRI KUNAL ZATAKIA (<i>Alternate I</i>) SHRI VARUN SHAH (<i>Alternate II</i>)
TTS Consultant, Kolkata	SHRI TARAK CHAKRABORTY
Uttar Pradesh Fire Service, Government of Uttar Pradesh, Lucknow	SHRI AMAN SHARMA
In Personal Capacity (<i>K-33-A, Green Park, First Floor, New Delhi</i>)	SHRI S. K. DHERI
In Personal Capacity (<i>27A, Tapovan Senior Citizens Foundation, Coimbatore</i>)	SHRI T. R. A. KRISHNAN
In Personal Capacity (<i>Bldg. No.8/S/3, Kamat Classic, Phase 4, Caranzalem, Panaji</i>)	SHRI ASHOK MENON
In Personal Capacity (<i>Gheekanta Road, Near Madhuram Cinema, Ahmedabad</i>)	SHRI ABHAY D. PURANDARE
In Personal Capacity (<i>D-317, 2nd Floor, Nirman Vihar, New Delhi</i>)	SHRI R. C. SHARMA
BIS Directorate General	SHRI DWAIPAYAN BHADRA, SCIENTIST 'E'/DIRECTOR AND HEAD (CIVIL ENGINEERING) [REPRESENTING DIRECTOR GENERAL (<i>Ex-officio</i>)]

Member Secretary
SHRI RAJESH CHOUDHARY
SCIENTIST 'B'/ASSISTANT DIRECTOR
(CIVIL ENGINEERING), BIS

Helmet Subcommittee, CED 22 : 5

<i>Organization</i>	<i>Representative(s)</i>
In Personal Capacity (<i>Bldg. No.8/S/3, Kamat Classic, Phase 4, Caranzalem, Panaji</i>)	SHRI ASHOK MENON (<i>Convener</i>)
3M India Limited, Bengaluru	SHRI VINAY PATHAK SHRI BIDYUT CHETIA (<i>Alternate</i>)
All India Helmets Manufacturers Association, Faridabad	SHRI MADHU BHUSHAN KHURANA
All India Two Wheeler's Helmet Manufacturers Association, Delhi	SHRI GOVIND PARSAD DABRAL SHRI BHARAT BHUSHAN (<i>Alternate</i>)
Automotive Research Association of India, Pune	SHRI B. S. YAMGAR
Bureau of Police Research and Development, New Delhi	PRINCIPAL SCIENTIFIC OFFICER DR M. M. GOSAL (<i>Alternate</i>)
Coal India Limited, Dhanbad	SHRI G. C. SHARMA SHRI A. B. W. HUSSAIN (<i>Alternate</i>)
Concert Trust, Consumers Association of India, Chennai	SHRI M. R. KRISHNAN SHRI M. SOMASUNDARAM (<i>Alternate</i>)
Concord Arai Private Limited, Chennai	SHRI R. RAM KRISHANAN SHRI A. R. D. RAMACHANDRA RAJA (<i>Alternate</i>)
CSIR - Central Institute for Mining and Fuel Research, Dhanbad	DR HARENDRA SINGH
Defence Bio-Engineering and Electromedical Laboratory, Ministry of Defence, Bengaluru	DR R. INDUSHEKAR SHRI TAPAN KHILARIWAL (<i>Alternate</i>)
Defence Materials and Stores Research and Development Establishment, Kanpur	DR R. K. TIWARI SHRI ARUN KUMAR SINGH (<i>Alternate</i>)
Directorate General of Mines Safety, Dhanbad	SHRI C. B. PRASAD SHRI N. P. DEORI (<i>Alternate</i>)
Hero Motocorp Limited, New Delhi	SHRI HARJEET SINGH SHRI PIYUSH CHOWDHRY (<i>Alternate</i>)
Honeywell International India Private Limited, Gurugram	SHRI RAVI AVUPATI
Indian Institute of Technology Delhi, New Delhi	DR SANJEEV SANGI DR PUNEET MAHAJAN (<i>Alternate</i>)
Mines Safety Appliances Limited, Kolkata	SHRI K. SANYAL SHRI S. BHATTACHARYA (<i>Alternate</i>)
Ministry of Home Affairs, New Delhi	SHRI PRASHANT LONKAR SHRI MORESHWAR KUDKILWAR (<i>Alternate</i>)
Ministry of Road Transport and Highways, New Delhi	SHRI S. P. GUPTA SHRI K. C. SHARMA (<i>Alternate</i>)
Society of Indian Automobile Manufacturers (SIAM), Delhi	SHRI PRASHANT KUMAR BANERJEE ASSISTANT DIRECTOR (<i>Alternate</i>)

<i>Organization</i>	<i>Representative(s)</i>
Steelbird Hi-Tech India Limited, Solan	SHRI RAJEEV KAPUR SHRI ARUN KUMAR (<i>Alternate</i>)
STUDDS Accessories Limited, Faridabad	SHRI SIDHARTHA KHURANA
Voluntary Organisation in Interest of Consumer Education (VOICE), New Delhi	SHRI M. A. U. KHAN SHRI RAJIV JHA (<i>Alternate</i>)
In Personal Capacity (<i>D-317, 2nd Floor, Nirman Vihar, New Delhi</i>)	SHRI R. C. SHARMA

Bureau of Indian Standards

BIS is a statutory institution established under the *Bureau of Indian Standards Act, 2016* to promote harmonious development of the activities of standardization, marking and quality certification of goods and attending to connected matters in the country.

Copyright

BIS has the copyright of all its publications. No part of these publications may be reproduced in any form without the prior permission in writing of BIS. This does not preclude the free use, in the course of implementing the standard, of necessary details, such as symbols and sizes, type or grade designations. Enquiries relating to copyright be addressed to the Head (Publication & Sales), BIS.

Review of Indian Standards

Amendments are issued to standards as the need arises on the basis of comments. Standards are also reviewed periodically; a standard along with amendments is reaffirmed when such review indicates that no changes are needed; if the review indicates that changes are needed, it is taken up for revision. Users of Indian Standards should ascertain that they are in possession of the latest amendments or edition by referring to the website-www.bis.gov.in or www.standardsbis.in.

This Indian Standard has been developed from Doc No.: CED 22 (22809).

Amendments Issued Since Publication

Amend No.	Date of Issue	Text Affected

BUREAU OF INDIAN STANDARDS

Headquarters:

Manak Bhavan, 9 Bahadur Shah Zafar Marg, New Delhi 110002

Telephones: 2323 0131, 2323 3375, 2323 9402

Website: www.bis.gov.in

Regional Offices:

	Telephones
Central : 601/A, Konnectus Tower -1, 6 th Floor, DMRC Building, Bhavbhuti Marg, New Delhi 110002	{ 2323 7617
Eastern : 8 th Floor, Plot No 7/7 & 7/8, CP Block, Sector V, Salt Lake, Kolkata, West Bengal 700091	{ 2367 0012 2320 9474
Northern : Plot No. 4-A, Sector 27-B, Madhya Marg, Chandigarh 160019	{ 265 9930
Southern : C.I.T. Campus, IV Cross Road, Taramani, Chennai 600113	{ 2254 1442 2254 1216
Western : 5 th Floor/MTNL CETTM Technology Street, Hiranandani Gardens, Powai, Mumbai - 400076	{ 283 25838

Branches : AHMEDABAD, BENGALURU, BHOPAL, BHUBANESHWAR, CHANDIGARH, CHENNAI, COIMBATORE, DEHRADUN, DELHI, FARIDABAD, GHAZIABAD, GUWAHATI, HARYANA (CHANDIGARH), HUBLI, HYDERABAD, JAIPUR, JAMMU, JAMSHEDPUR, KOCHI, KOLKATA, LUCKNOW, MADURAI, MUMBAI, NAGPUR, NOIDA, PARWANOO, PATNA, PUNE, RAIPUR, RAJKOT, SURAT, VIJAYAWADA.