

भारतीय मानक

IS 3908 : 2024

Indian Standard

(Amalgamating IS 3909, IS 3921 and
IS 5384)

एल्युमिनियम बीम, चैनल और कोण
अनुभाग — आयाम और गुण

(दूसरा पुनरीक्षण)

Aluminium Beam, Channel and
Angle Sections — Dimensions and
Properties

(Second Revision)

ICS 77.150.10

© BIS 2024



भारतीय मानक ब्यूरो
BUREAU OF INDIAN STANDARDS
मानक भवन, 9 बहादुर शाह ज़फर मार्ग, नई दिल्ली - 110002
MANAK BHAVAN, 9 BAHADUR SHAH ZAFAR MARG
NEW DELHI - 110002

www.bis.gov.in www.standardsbis.in

November 2024

Price Group 10

FOREWORD

This Indian Standard (Second Revision) was adopted by the Bureau of Indian Standards, after the draft finalized by the Structural Engineering and Structural Sections Sectional Committee had been approved by the Civil Engineering Division Council.

Aluminium, because of its lightness, strength and better resistance to atmospheric corrosion, has gained popularity in structures especially for use in hilly area and in defence establishments.

A large number of variety of aluminium sections are being produced in the country. In order to standardize these sections for their economic production, the Committee had formulated Indian Standard series covering angles, channels, beams and tee sections for structural use and other applications.

Bureau of Indian Standards had first published IS 3908 for aluminium equal leg angles in 1966, IS 3909 for aluminium unequal leg angles in 1966, IS 3921 for aluminium channels in 1966 and IS 5384 for aluminium 'I' beams in 1969. Their first revisions were published as follows:

IS 3908 : 1986 Specification for aluminium equal leg angles (*first revision*)

IS 3909 : 1986 Specification for aluminium unequal leg angles (*first revision*)

IS 3921 : 1985 Specification for aluminium channels (*first revision*)

IS 5384 : 1985 Specification for aluminium I-beams (*first revision*)

In this revision, in view of the recent developments that have taken place, the Committee viewed that these standards be revised and amalgamated into one standard, that is, IS 3908. The amalgamation will facilitate better access of the sectional details under one resource document. The following additional modifications have been effected in this revision:

- a) Cross reference have been updated; and
- b) Tables for aluminium sections have been updated.

A code of practice for use of aluminium alloys in structure namely IS 8147 : 1976 'Code of practice for use of aluminium alloys in structures' was published which covers provisions for the design of structures (except bridges and pressure vessels) using aluminium alloys.

In the formulation of this standard, assistance has been derived from:

BS 1161 : 1977 'Specification for aluminium alloy sections for structural purposes'.

The composition of the Committee responsible for the formulation of this standard is given in [Annex A](#).

For the purpose of deciding whether a particular requirement of this standard is complied with, the final value, observed or calculated, expressing the result of a test or analysis shall be rounded off in accordance with IS 2 : 2022 'Rules for rounding off numerical values (*second revision*)'. The number of significant places retained in the rounded off value should be the same as that of the specified value in this standard.

Indian Standard

ALUMINIUM BEAM, CHANNEL AND ANGLE SECTIONS —
DIMENSIONS AND PROPERTIES

(Second Revision)

1 SCOPE

This standard covers the material, dimensions and sectional properties of aluminium equal leg angle, unequal leg angle, channel and 'I' beam sections for structural use and other applications.

2 REFERENCES

The standards given below contain provisions, which through reference in this text constitute provisions of this standard. At the time of publication, the editions indicated were valid. All standards are subject to revision and parties to agreement based on this standard are encouraged to investigate the possibility of applying the most recent edition of these standards:

IS No.	Title
IS 733 : 1983	Specification for wrought aluminium and aluminium alloy bars, rods and sections (for general engineering purposes) (<i>third revision</i>)
IS 3965 : 1981	Dimensions for wrought aluminium and aluminium alloys, bar, rod and section (<i>first revision</i>)

3 TERMINOLOGY

For the purpose of this standard the following definitions shall apply.

3.1 Moment of Inertia — The quantity expressed by the section resisting angular acceleration which is the sum of the product of the mass of every particle with its square of a distance from the axis of rotation.

3.2 Radii of Gyration — As a measure of the way in which the mass of a rotating rigid body is distributed about the axis of rotation.

3.3 U-U and V-V Axes — Lines passing through the centre of gravity of the profile of the section, representing the principal axes of angle sections, where U-U is a major axis (when it does not coincide with Z-Z axis) and V-V axis is a minor axis (when it does not coincide with Y-Y axis).

3.4 X-X Axis — A line along the member passing through the centre of gravity of the sections profile.

3.5 Y-Y Axis — A line perpendicular to the flanges (in case of beams and channels) or perpendicular to the smaller leg (in case of an angle section) and passing through the centre of gravity of the sections profile.

3.6 Z-Z Axis — A line parallel to the flanges (in case of beams and channels) or parallel to the smaller leg (in case of an angle section) and passing through the centre of gravity of the sections profile.

4 SYMBOLS

4.1 Letter symbols used in this standard have been indicated in the Fig. 1 to Fig. 4. The letter symbols used in Table 1 to Table 4 shall have the meaning indicated against each as given below:

a	Sectional area
e_Y	Distance of extreme fibre from the Y-Y axis, $(B - C_Y)$
e_Z	Distance of extreme fibre from the Z-Z axis, $(A - C_Z)$
I_U	Moment of inertia (<i>Max</i>) about the U-U axis
I_V	Moment of inertia (<i>Min</i>) about the V-V axis
I_Y	Moment of inertia about the Y-Y axis
I_Z	Moment of inertia about the Z-Z axis
K	Torsional constant
M	Mass of the section per unit length
$r_u = \sqrt{\frac{I_u}{a}}$	Radius of gyration about the U-U axis
$r_v = \sqrt{\frac{I_v}{a}}$	Radius of gyration about the V-V axis
$r_y = \sqrt{\frac{I_y}{a}}$	Radius of gyration about the Y-Y axis

To access Indian Standards click on the link below:

https://www.services.bis.gov.in/php/BIS_2.0/bisconnect/knownyourstandards/Indian_standards/isdetails/

$$r_z = \sqrt{\frac{I_z}{a}}$$

Radius of gyration about the Z-Z axis

$$Z_z = \frac{I_z}{e_z}$$

Modulus of section about the Z-Z axis

$$Z_y = \frac{I_y}{e_y}$$

Modulus of section about the Y-Y axis

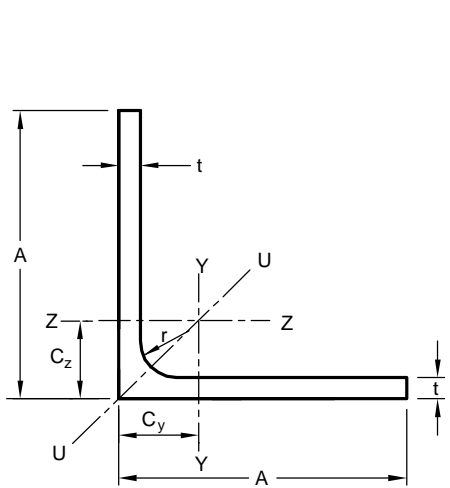

FIG. 1 ALUMINIUM EQUAL LEG ANGLES

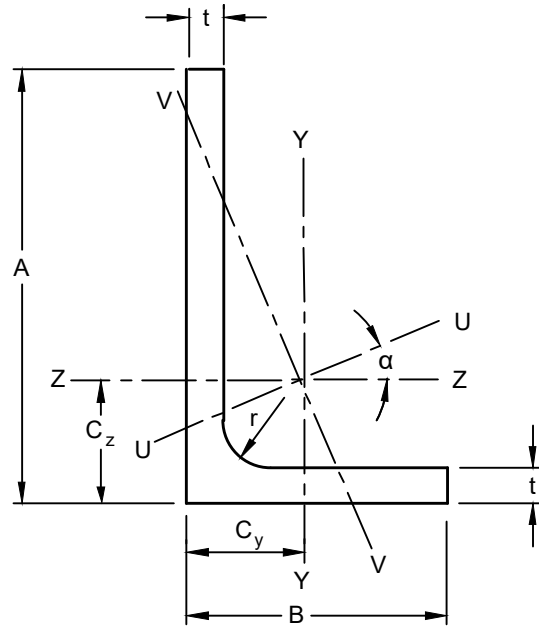

FIG. 2 ALUMINIUM UNEQUAL LEG ANGLE

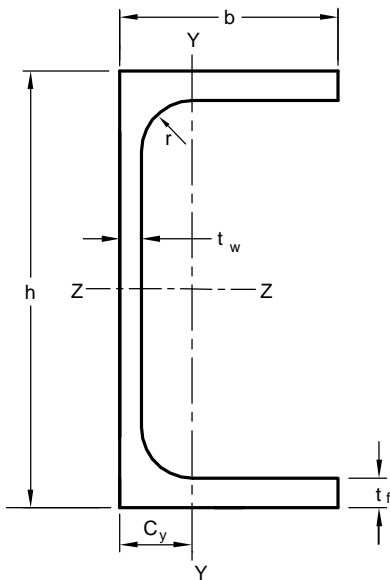

FIG. 3 ALUMINIUM CHANNEL SECTION

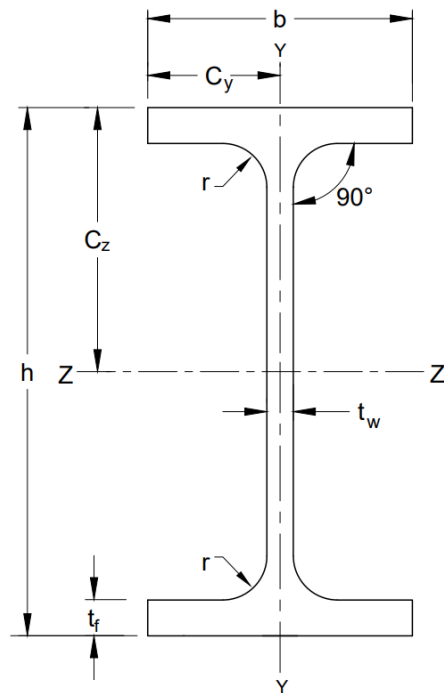

FIG. 4 ALUMINIUM I-BEAM

Table 1 Indian Standard Aluminium Equal Leg Angles

(Clauses 4.1, 6.1 and 6.1.1)

SI No.	Designation and Size (A × B × t) (in mm)	Mass* Per Metre	Sectional Area	Radius at Root	Centre of Gravity	Moment of Inertia			Radius of Gyration			Modulus of Section
						$I_z = I_y$	I_u (Min)	I_v (Min)	$r_z = r_y$	r_u (Min)	r_v (Min)	
		(M)	(a)	(r)	$C_z = C_y$	$I_z = I_y$	I_u (Min)	I_v (Min)	$r_z = r_y$	r_u (Min)	r_v (Min)	$Z_z = Z_y$
		kg/m	cm ²	mm	cm	cm ⁴	cm ⁴	cm ⁴	cm	cm	cm	cm ³
(1)	(2)	(3)	(4)	(5)	(6)	(7)	(8)	(9)	(10)	(11)	(12)	(13)
i)	ALE10 × 10 × 1.5	0.08	0.30	3.0	0.30	0.03	0.04	0.01	0.29	0.37	0.19	0.04
ii)	ALE10 × 10 × 2.0	0.10	0.38	3.0	0.32	0.03	0.05	0.01	0.29	0.36	0.19	0.05
iii)	ALE15 × 15 × 1.5	0.12	0.45	3.0	0.42	0.09	0.15	0.04	0.45	0.57	0.29	0.09
iv)	ALE15 × 15 × 2.0	0.16	0.58	3.0	0.44	0.12	0.18	0.05	0.45	0.56	0.29	0.11
v)	ALE15 × 15 × 3.0	0.22	0.83	3.0	0.48	0.16	0.25	0.07	0.44	0.55	0.29	0.16
vi)	ALE20 × 20 × 2.0	0.21	0.79	4.0	0.56	0.29	0.46	0.12	0.61	0.76	0.39	0.20
vii)	ALE20 × 20 × 3.0	0.31	1.14	4.0	0.60	0.40	0.64	0.17	0.59	0.75	0.39	0.29
viii)	ALE25 × 25 × 2.0	0.27	0.99	4.0	0.68	0.58	0.92	0.24	0.77	0.96	0.50	0.32
ix)	ALE25 × 25 × 3.0	0.39	1.44	4.0	0.73	0.82	1.31	0.34	0.76	0.95	0.49	0.47
x)	ALE25 × 25 × 4.0	0.51	1.87	4.0	0.77	1.04	1.64	0.44	0.74	0.93	0.48	0.60
xi)	ALE30 × 30 × 2.5	0.40	1.49	5.0	0.82	1.26	1.98	0.53	0.92	1.15	0.6	0.578
xii)	ALE30 × 30 × 3.0	0.48	1.76	5.0	0.85	1.47	2.33	0.61	0.91	1.15	0.59	0.68
xiii)	ALE30 × 30 × 3.0	0.62	2.29	5.0	0.89	1.86	2.95	0.78	0.90	1.13	0.58	0.88

*Based on density of 2.7 gm/cm³.

Table 1 (Continued)

SI No.	Designation and Size (A × B × t) (in mm)	Mass* Per Metre	Sectional Area	Radius at Root	Centre of Gravity	Moment of Inertia			Radius of Gyration			Modulus of Section
						$I_z = I_y$	I_u (Min)	I_v (Min)	$r_z = r_y$	r_u (Min)	r_v (Min)	
		(M)	(a)	(r)	$C_z = C_y$	$I_z = I_y$	I_u (Min)	I_v (Min)	$r_z = r_y$	r_u (Min)	r_v (Min)	$Z_z = Z_y$
		kg/m	cm ²	mm	cm	cm ⁴	cm ⁴	cm ⁴	cm	cm	cm	cm ³
(1)	(2)	(3)	(4)	(5)	(6)	(7)	(8)	(9)	(10)	(11)	(12)	(13)
xiv)	ALE30 × 30 × 5.0	0.76	2.80	5.0	0.93	2.22	3.50	0.94	0.89	1.12	0.58	1.07
xv)	ALE35 × 35 × 3.0	0.56	2.06	5.0	0.97	2.38	3.77	0.99	1.07	1.35	0.69	0.94
xvi)	ALE35 × 35 × 4.0	0.73	2.69	5.0	1.01	3.04	4.81	1.26	1.06	1.34	0.69	1.22
xvii)	ALE35 × 35 × 5.0	0.89	3.30	5.0	1.05	3.66	5.76	1.53	1.05	1.32	0.68	1.49
xviii)	ALE40 × 40 × 3.0	0.64	2.36	5.0	1.10	3.61	5.72	1.50	1.24	1.56	0.80	1.24
xix)	ALE40 × 40 × 4.0	0.84	3.09	5.0	1.14	4.63	7.34	1.92	1.22	1.54	0.79	1.62
xx)	ALE40 × 40 × 5.0	1.03	3.80	5.0	1.18	5.58	8.84	2.32	1.21	1.52	0.78	1.98
xxi)	ALE45 × 45 × 3.0	0.73	2.69	6.0	1.21	5.21	8.22	2.20	1.39	1.75	0.90	1.58
xxii)	ALE45 × 45 × 4.0	0.95	3.52	6.0	1.26	6.66	10.61	2.71	1.38	1.74	0.88	2.06
xxiii)	ALE45 × 45 × 5.0	1.17	4.33	6.0	1.30	8.06	12.83	3.29	1.36	1.72	0.87	2.52
xxiv)	ALE50 × 50 × 3.0	0.81	2.99	6.0	1.34	7.22	11.43	3.00	1.55	1.96	1.00	1.97
xxv)	ALE50 × 50 × 4.0	0.06	3.92	6.0	1.38	9.32	14.78	3.86	1.54	1.94	0.99	2.57
xxvi)	ALE50 × 50 × 5.0	1.30	4.83	6.0	1.42	11.30	17.92	4.68	1.53	1.93	0.98	3.16

*Based on density of 2.7 gm/cm².

Table 1 (Continued)

SI No.	Designation and Size (A × B × t) (in mm)	Mass* Per Metre	Sectional Area	Radius at Root	Centre of Gravity	Moment of Inertia			Radius of Gyration			Modulus of Section
						$I_z = I_y$	I_u (Min)	I_v (Min)	$r_z = r_y$	r_u (Min)	r_v (Min)	
		(M)	(a)	(r)	$C_z = C_y$	$I_z = I_y$	I_u (Min)	I_v (Min)	$r_z = r_y$	r_u (Min)	r_v (Min)	$Z_z = Z_y$
		kg/m	cm ²	mm	cm	cm ⁴	cm ⁴	cm ⁴	cm	cm	cm	cm ³
(1)	(2)	(3)	(4)	(5)	(6)	(7)	(8)	(9)	(10)	(11)	(12)	(13)
xxvii)	ALE50 × 50 × 6.0	1.54	5.72	6.0	1.46	13.17	20.86	5.47	1.52	1.91	0.98	3.72
xxviii)	ALE60 × 60 × 3.5	1.17	4.31	7.0	1.57	14.7	23.1	6.31	1.85	2.31	1.21	3.32
xxix)	ALE60 × 60 × 4.0	1.28	4.75	7.0	1.62	16.44	26.06	6.81	1.86	2.34	1.20	3.76
xxx)	ALE60 × 60 × 5.0	1.58	5.86	7.0	1.67	20.02	31.76	8.27	1.85	2.33	1.19	4.62
xxxi)	ALE60 × 60 × 6.0	1.88	6.95	7.0	1.71	23.43	37.16	9.69	1.84	2.31	1.18	5.46
xxxii)	ALE70 × 70 × 5.0	1.86	6.89	8.0	1.91	32.35	51.31	13.39	2.17	2.73	1.39	6.36
xxxiii)	ALE70 × 70 × 6.0	2.21	8.18	8.0	1.95	38.03	60.26	15.80	2.16	2.71	1.39	7.53
xxxiv)	ALE70 × 70 × 7.0	2.55	9.45	8.0	1.99	43.43	68.80	18.06	2.14	2.70	1.38	8.67
xxxv)	ALE80 × 80 × 5.0	2.23	8.23	8.0	2.11	49.5	77.7	21.3	2.45	3.07	1.61	8.40
xxxvi)	ALE80 × 80 × 6.0	2.53	9.38	8.0	2.20	57.59	91.48	23.71	2.48	3.12	1.59	9.93
xxxvii)	ALE80 × 80 × 8.0	3.32	12.30	8.0	2.28	73.97	117.43	30.50	2.45	3.09	1.57	12.93
xxxviii)	ALE80 × 80 × 10.0	4.09	15.14	8.0	2.36	89.18	141.32	37.04	2.43	3.06	1.56	15.80
xxxix)	ALE100 × 100 × 6.0	3.17	11.81	9.0	2.72	115.15	182.92	47.42	3.10	3.92	1.99	15.78

*Based on density of 2.7 gm/cm².

Table 1 (Continued)

Sl No.	Designation and Size (A × B × t) (in mm)	Mass* Per Metre	Sectional Area	Radius at Root	Centre of Gravity	Moment of Inertia			Radius of Gyration			Modulus of Section
						$I_z = I_y$	I_u (Min)	I_v (Min)	$r_z = r_y$	r_u (Min)	r_v (Min)	
		(M)	(a)	(r)	$C_z = C_y$	$I_z = I_y$	I_u (Min)	I_v (Min)	$r_z = r_y$	r_u (Min)	r_v (Min)	$Z_z = Z_y$
		kg/m	cm ²	mm	cm	cm ⁴	cm ⁴	cm ⁴	cm	cm	cm	cm ³
(1)	(2)	(3)	(4)	(5)	(6)	(7)	(8)	(9)	(10)	(11)	(12)	(13)
xl)	ALE100 × 100 × 8.0	4.19	15.53	9.0	2.78	148.73	236.41	61.06	3.09	3.92	1.98	20.59
xli)	ALE100 × 100 × 10.0	5.18	19.17	9.0	2.85	180.49	286.67	74.30	3.07	3.87	1.97	25.23
xlii)	ALE120 × 120 × 12.0	6.14	22.73	9.0	2.93	210.43	333.70	87.15	3.04	3.83	1.96	29.76
xliii)	ALE120 × 120 × 7.0	4.68	17.3	10.0	3.14	235	370	110	3.69	4.63	2.42	26.6
xliv)	ALE120 × 120 × 10.0	6.27	23.21	10.0	3.35	319.51	508.04	130.99	3.71	4.68	2.38	36.94
xlv)	ALE120 × 120 × 12.0	7.45	27.57	10.0	3.43	374.13	594.41	153.85	3.68	4.64	2.36	43.64
xlvi)	ALE120 × 120 × 16.0	9.73	36.05	10.0	3.58	475.66	753.35	191.97	3.63	4.57	2.34	56.43
xlvii)	ALE150 × 150 × 10.0	7.91	29.31	12.0	4.09	639.75	1017.61	261.88	4.67	5.89	2.99	58.64

*Based on density of 2.7 gm/cm³.

Table 1 (Concluded)

Sl No.	Designation and Size (A × B × t) (in mm)	Mass* Per Metre	Sectional Area	Radius at Root	Centre of Gravity	Moment of Inertia			Radius of Gyration			Modulus of Section
						$I_z = I_y$	I_u (Min)	I_v (Min)	$r_z = r_y$	r_u (Min)	r_v (Min)	
		(M)	(a)	(r)	$C_z = C_y$	$I_z = I_y$	I_u (Min)	I_v (Min)	$r_z = r_y$	r_u (Min)	r_v (Min)	$Z_z = Z_y$
		kg/m	cm ²	mm	cm	cm ⁴	cm ⁴	cm ⁴	cm	cm	cm	cm ³
(1)	(2)	(3)	(4)	(5)	(6)	(7)	(8)	(9)	(10)	(11)	(12)	(13)
xlvi)	ALE150 × 150 × 12.0	9.41	34.87	12.0	4.17	752.41	1 196.72	308.11	4.65	5.86	2.97	69.47
xlix)	ALE150 × 150 × 16.0	12.35	45.75	12.0	4.32	964.79	1 532.30	397.29	4.59	5.79	2.95	90.35
i)	ALE200 × 200 × 12.0	12.72	47.11	16.0	5.40	1 838.49	2 923.90	753.08	6.25	7.88	4.00	125.92
ii)	ALE200 × 200 × 16.0	16.74	61.99	16.0	5.56	2 782.00	3 782.21	973.79	6.19	7.81	3.96	164.68
iii)	ALE200 × 200 × 20.0	20.67	76.55	16.0	5.71	2 886.35	4 586.40	1 186.30	6.14	7.74	3.94	202.02

*Based on density of 2.7 gm/cm³.

Table 2 Indian Standard Aluminium Unequal Leg Angles

(Clauses 4.1, 6.1 and 6.1.1)

SI No.	Designation and Size	Mass* per Metre	Sectional Area	Radius at Root	Centre of Gravity		Moment of Inertia				Radius of Gyration				Modulus of Section		Tan α
					C_z	C_y	I_z	I_y	I_u Max	I_v Min	r_z	r_y	r_u Max	r_v Min	Z_z	Z_y	
	(A × B × t, in mm)	kg/m	cm ²	mm	cm	cm	cm ⁴	cm ⁴	cm ⁴	cm ⁴	cm	cm	cm	cm	cm ³	cm ³	
(1)	(2)	(3)	(4)	(5)	(6)	(6)	(7)	(8)	(9)	(10)	(11)	(12)	(13)	(14)	(15)	(16)	(17)
i)	ALU20 × 10 × 1.5	0.12	0.46	4.0	0.69	0.23	0.18	0.03	0.20	0.02	0.63	0.26	0.65	0.21	0.14	0.04	0.26
ii)	ALU20 × 10 × 2.0	0.16	0.59	4.0	0.72	0.25	0.23	0.04	0.25	0.03	0.63	0.26	0.64	0.21	0.18	0.18	0.26
iii)	ALU20 × 15 × 1.5	0.14	0.54	4.0	0.60	0.37	0.21	0.10	0.25	0.06	0.62	0.43	0.69	0.32	0.15	0.15	0.54
iv)	ALU20 × 15 × 2.0	0.19	0.69	4.0	0.63	0.39	0.27	0.13	0.32	0.07	0.62	0.43	0.68	0.32	0.19	0.19	0.54
v)	ALU20 × 15 × 3.0	0.27	0.99	4.0	0.67	0.43	0.37	0.17	0.45	0.10	0.61	0.42	0.67	0.31	0.28	0.28	0.54
vi)	ALU30 × 15 × 2.0	0.25	0.91	5.0	1.03	0.33	0.84	0.14	0.89	0.09	0.96	0.39	0.98	0.32	0.42	0.12	0.26
vii)	ALU30 × 15 × 3.0	0.35	1.31	5.0	1.09	0.37	1.17	0.20	1.24	0.13	0.94	0.39	0.97	0.31	0.61	0.17	0.25
viii)	ALU30 × 20 × 2.0	0.27	1.01	5.0	0.94	0.47	0.92	0.33	1.05	0.19	0.95	0.57	1.02	0.43	0.44	0.21	0.43
ix)	ALU30 × 20 × 3.0	0.40	1.46	5.0	0.99	0.51	1.29	0.46	1.48	0.27	0.94	0.56	1.01	0.43	0.64	0.31	0.43
x)	ALU30 × 20 × 4.0	0.51	1.89	5.0	1.03	0.55	1.63	0.57	1.86	0.34	0.93	0.55	0.99	0.42	0.85	0.39	0.42
xi)	ALU40 × 20 × 2.0	0.32	1.21	5.0	1.36	0.41	2.03	0.35	2.15	0.23	1.29	0.54	1.33	0.43	0.77	0.22	0.26
xii)	ALU40 × 20 × 3.0	0.48	1.76	5.0	1.42	0.45	2.89	0.49	3.06	0.32	1.28	0.53	1.32	0.43	1.12	0.32	0.26
xiii)	ALU40 × 20 × 4.0	0.62	2.29	5.0	1.46	0.49	3.67	0.62	3.89	0.41	1.27	0.52	1.30	0.42	1.45	0.41	0.25
xiv)	ALU40 × 25 × 2.0	0.36	1.34	6.0	1.25	0.54	2.19	0.67	2.45	0.41	1.28	0.71	1.35	0.55	0.80	0.34	0.38

*Based on density of 2.7 gm/cm³

Table 2 (Continued)

SI No.	Designation and Size	Mass* per Metre	Sectional Area	Radius at Root	Centre of Gravity		Moment of Inertia				Radius of Gyration				Modulus of Section		Tan α
					C_z	C_y	I_z	I_y	I_u Max	I_v Min	r_z	r_y	r_u Max	r_v Min	Z_z	Z_y	
	(A × B × t, in mm)	kg/m	cm ²	mm	cm	cm	cm ⁴	cm ⁴	cm ⁴	cm ⁴	cm	cm	cm	cm	cm ³	cm ³	
(1)	(2)	(3)	(4)	(5)	(6)	(6)	(7)	(8)	(9)	(10)	(11)	(12)	(13)	(14)	(15)	(16)	(17)
xv)	ALU40 × 25 × 3.0	0.52	1.94	6.0	1.31	0.59	3.13	0.94	3.50	0.57	1.27	0.70	1.34	0.54	1.16	0.49	0.38
xvi)	ALU40 × 25 × 4.0	0.68	2.52	6.0	1.35	0.63	3.98	1.19	4.46	0.72	1.26	0.69	1.33	0.53	1.51	0.64	0.38
xvii)	ALU45 × 30 × 3.0	0.60	2.24	6.0	1.43	0.70	4.56	1.65	5.25	0.96	1.43	0.86	1.53	0.66	1.49	0.72	0.44
xviii)	ALU45 × 30 × 4.0	0.79	2.92	6.0	1.47	0.74	5.91	2.10	6.76	1.52	1.42	0.85	1.25	0.65	1.95	0.93	0.43
xix)	ALU45 × 30 × 5.0	0.97	3.58	6.0	1.52	0.78	7.04	2.51	8.08	1.50	1.40	0.84	1.47	0.64	2.36	1.13	0.40
xx)	ALU50 × 25 × 3.0	0.60	2.24	6.0	1.74	0.53	5.80	1.00	6.15	0.65	1.61	0.67	1.66	0.54	1.78	0.50	0.26
xxi)	ALU50 × 25 × 4.0	0.79	2.92	6.0	1.79	0.57	7.43	1.26	7.87	0.82	1.60	0.66	1.64	0.53	2.31	0.65	0.26
xxii)	ALU50 × 25 × 5.0	0.97	3.58	6.0	1.83	0.61	8.96	1.50	9.47	0.99	1.58	0.65	1.63	0.53	2.83	0.79	0.25
xxiii)	ALU50 × 30 × 3.0	0.64	2.39	6.0	1.64	0.67	6.15	1.69	6.81	1.03	1.61	0.84	1.69	0.66	1.83	0.74	0.36
xxiv)	ALU50 × 30 × 4.0	0.84	3.12	6.0	1.68	0.71	7.91	2.16	8.75	1.32	1.59	0.83	1.68	0.65	2.38	0.94	0.36
xxv)	ALU50×30×5.0	1.03	3.83	6.0	1.73	0.75	9.55	2.58	10.54	1.59	1.58	0.82	1.66	0.64	2.92	1.15	0.35
xxvi)	ALU50 × 38 × 3.0	0.74	2.72	7.0	1.47	0.90	6.72	3.35	8.21	1.86	1.57	1.11	1.74	0.82	1.90	1.16	0.55
xxvii)	ALU50 × 38 × 4.0	0.95	3.50	7.0	1.53	0.95	8.60	4.28	10.5	2.34	1.57	1.11	1.74	8.1	2.48	1.50	0.56
xxviii)	ALU60 × 30 × 3.0	0.73	2.72	7.0	2.05	0.61	10.22	1.77	10.84	1.15	1.94	0.81	2.00	0.65	2.59	0.74	0.26

*Based on density of 2.7 gm/cm³

Table 2 (Continued)

SI No.	Designation and Size	Mass* per Metre	Sectional Area	Radius at Root	Centre of Gravity		Moment of Inertia				Radius of Gyration				Modulus of Section		Tan α
					C_z	C_y	I_z	I_y	I_u Max	I_v Min	r_z	r_y	r_u Max	r_v Min	Z_z	Z_y	
	(A × B × t, in mm)	kg/m	cm ²	mm	cm	cm	cm ⁴	cm ⁴	cm ⁴	cm ⁴	cm	cm	cm	cm	cm ³	cm ³	
(1)	(2)	(3)	(4)	(5)	(6)	(6)	(7)	(8)	(9)	(10)	(11)	(12)	(13)	(14)	(15)	(16)	(17)
xxix)	ALU60 × 30 × 4.0	0.96	3.55	7.0	2.11	0.65	13.16	2.25	13.96	1.46	1.93	0.80	1.98	0.64	3.38	0.96	0.26
xxx)	ALU60 × 30 × 5.0	1.18	4.36	7.0	2.15	0.69	15.94	2.70	16.88	1.76	1.91	0.79	1.97	0.64	4.15	1.17	0.26
xxxii)	ALU60 × 40 × 4.0	1.07	3.95	7.0	1.93	0.94	14.48	5.20	16.66	3.02	1.92	1.15	2.05	0.88	3.54	1.70	0.44
xxxiii)	ALU60 × 40 × 5.0	1.31	4.86	7.0	1.96	0.98	17.58	6.28	20.21	3.65	1.90	1.14	1.98	0.87	4.25	2.08	0.43
xxxiv)	ALU60 × 40 × 6.0	1.55	5.75	7.0	2.00	0.61	20.52	7.29	23.55	4.26	1.89	1.13	1.97	0.86	5.13	2.45	0.43
xxxv)	ALU60 × 45 × 3.5	1.03	3.79	7.0	1.77	1.06	13.5	6.52	16.4	3.65	1.89	1.31	2.08	0.98	3.20	1.90	0.54
xxxvi)	ALU65 × 45 × 4.0	1.17	4.35	7.0	2.03	1.06	18.8	7.41	22.0	4.21	2.08	1.31	2.25	0.98	4.21	2.15	0.47
xxxvii)	ALU65 × 45 × 5.0	1.45	5.36	7.0	2.08	1.10	22.78	8.99	26.7	5.07	0.06	1.30	2.23	0.97	5.15	2.64	0.47
xxxviii)	ALU75 × 50 × 5.0	1.66	6.14	8.0	2.39	1.17	35.47	12.77	40.67	5.57	2.40	1.44	2.57	1.11	6.94	3.33	0.43
xxxix)	ALU75 × 50 × 6.0	1.97	7.28	8.0	2.44	1.21	41.42	14.91	47.54	8.79	2.39	1.43	2.56	1.10	18.19	3.93	0.43
xl)	ALU80 × 40 × 4.0	1.29	4.78	8.0	2.76	0.81	32.10	5.58	34.07	3.61	2.59	1.08	2.67	0.87	6.12	1.75	0.26
xli)	ALU80 × 40 × 6.0	1.88	6.98	8.0	2.85	0.89	45.87	7.84	48.62	5.09	2.56	1.06	2.64	0.85	8.91	2.52	0.26
xlii)	ALU80 × 40 × 8.0	2.46	9.10	8.0	2.94	0.97	58.51	9.84	61.86	6.49	2.54	1.04	2.61	0.84	11.57	3.25	0.25
xliii)	ALU80 × 60 × 4.0	1.51	5.58	8.0	2.39	1.41	36.59	17.86	44.76	9.68	2.56	1.79	2.83	1.32	6.52	3.89	0.55

*Based on density of 2.7 gm/cm³

Table 2 (Continued)

SI No.	Designation and Size	Mass* per Metre	Sectional Area	Radius at Root	Centre of Gravity		Moment of Inertia				Radius of Gyration				Modulus of Section		Tan α
					C_z	C_y	I_z	I_y	I_u Max	I_v Min	r_z	r_y	r_u Max	r_v Min	Z_z	Z_y	
	(A × B × t, in mm)	kg/m	cm ²	mm	cm	cm	cm ⁴	cm ⁴	cm ⁴	cm ⁴	cm	cm	cm	cm	cm ³	cm ³	
(1)	(2)	(3)	(4)	(5)	(6)	(6)	(7)	(8)	(9)	(10)	(11)	(12)	(13)	(14)	(15)	(16)	(17)
xlivii)	ALU80 × 60 × 5.0	1.96	7.23	8.0	2.36	1.43	45.6	21.9	55.2	12.3	2.51	1.74	2.76	1.30	8.08	4.79	0.54
xliv)	ALU80 × 60 × 6.0	2.21	8.18	8.0	2.43	1.50	52.59	25.50	64.31	13.78	2.54	1.77	2.80	1.30	9.53	5.66	0.55
xliv)	ALU80 × 60 × 8.0	2.89	10.70	8.0	2.56	1.57	67.38	32.46	82.20	17.64	2.51	1.74	2.77	1.28	12.37	7.33	0.55
xlvi)	ALU90 × 60 × 60	2.37	8.78	8.0	2.89	1.41	72.93	26.42	83.96	15.39	2.88	1.73	3.09	1.32	11.94	5.76	0.44
xlvii)	ALU100 × 50 × 6.0	2.38	8.81	9.0	3.51	1.06	91.88	15.91	97.53	10.27	3.23	1.34	3.33	1.08	14.16	4.04	0.26
xlviii)	ALU100 × 50 × 8.0	3.11	11.53	9.0	3.60	1.14	118.11	20.16	125.16	13.11	3.20	1.32	3.29	1.07	18.45	5.22	0.26
xliv)	ALU100 × 50 × 10.0	3.83	14.17	9.0	3.68	1.21	142.61	24.03	150.80	15.83	3.17	1.30	3.26	1.06	22.58	6.35	0.25
l)	ALU100 × 75 × 6.0	2.94	10.8	9.0	2.95	1.78	107	51.6	130	28.9	3.14	2.18	3.46	1.63	15.2	9.01	0.54
li)	ALU100 × 75 × 8.0	3.77	13.9	9.0	3.08	1.88	137	66.0	167	36.3	31.4	2.18	3.46	1.62	19.8	11.7	0.54
lii)	ALU100 × 80 × 6.0	2.87	10.61	9.0	2.97	1.98	107.33	61.52	137.22	31.63	3.18	2.41	3.60	1.73	15.26	10.22	0.63
liii)	ALU100 × 80 × 8.0	3.76	13.93	9.0	3.05	2.06	138.58	79.09	176.97	40.70	3.15	2.38	3.56	1.71	19.94	13.32	0.63
liv)	ALU100 × 80 × 10.0	4.64	17.17	9.0	3.13	2.14	167.96	96.46	214.01	49.41	3.13	2.36	3.53	1.70	24.44	16.28	0.62
lv)	ALU120 × 80 × 8.0	4.21	15.57	10.0	3.86	1.89	230.16	83.17	265.44	47.89	3.84	2.31	4.13	1.75	28.28	13.61	0.44
lvi)	ALU120 × 80 × 10.0	5.19	19.21	10.0	3.94	1.97	279.93	100.45	322.29	58.09	3.82	2.29	4.10	1.74	34.74	16.64	0.44

*Based on density of 2.7 gm/cm³

Table 2 (Continued)

SI No.	Designation and Size	Mass* per Metre	Sectional Area	Radius at Root	Centre of Gravity		Moment of Inertia				Radius of Gyration				Modulus of Section		Tan α
					C_z	C_y	I_z	I_y	I_u Max	I_v Min	r_z	r_y	r_u Max	r_v Min	Z_z	Z_y	
	(A × B × t, in mm)	kg/m	cm ²	mm	cm	cm	cm ⁴	cm ⁴	cm ⁴	cm ⁴	cm	cm	cm	cm	cm ³	cm ³	
(1)	(2)	(3)	(4)	(5)	(6)	(6)	(7)	(8)	(9)	(10)	(11)	(12)	(13)	(14)	(15)	(16)	(17)
lvii)	ALU120 × 80 × 12.0	6.15	22.77	10.0	4.02	2.04	327.13	116.60	375.79	67.94	3.79	2.26	4.06	1.73	41.00	19.57	0.43
lviii)	ALU120 × 90 × 7	4.11	15.2	10.0	3.52	2.13	216	104	262	58.5	3.78	2.62	4.16	1.96	25.6	15.2	0.54
lix)	ALU120 × 90 × 10	5.65	20.9	10.0	3.70	2.26	295	142	358	78.1	3.76	2.60	4.14	1.94	35.5	21.0	0.54
lx)	ALU125 × 80 × 8.0	4.31	15.97	10.0	4.07	1.85	257.62	84.05	292.35	49.32	4.02	2.29	4.28	1.76	30.56	13.67	0.41
lxi)	ALU125 × 80 × 10.0	5.32	19.71	10.0	4.15	1.93	313.57	101.54	355.28	59.83	3.99	2.27	4.25	1.74	37.57	16.72	0.41
lxii)	ALU125 × 80 × 12.0	6.31	23.37	10.0	4.23	2.00	365.72	117.88	414.63	69.98	3.96	2.25	4.22	1.73	44.36	19.66	0.40
lxiii)	ALU140 × 105 × 8.5	5.83	21.5	12.0	4.13	2.49	416	200	504	112	4.40	3.05	4.84	2.28	42.2	25.0	0.54
lxiv)	ALU140 × 105 × 11	7.26	26.8	12.0	4.30	2.62	518	250	630	137	4.40	3.05	4.85	2.26	53.4	31.7	0.54
lxv)	ALU150 × 80 × 8.0	4.88	18.07	12.0	5.13	1.69	426.69	87.93	459.21	55.41	4.86	2.21	5.04	1.75	43.22	13.93	0.30
lxvi)	ALU150 × 80 × 10.0	6.02	22.31	12.0	5.22	1.77	520.60	106.29	559.73	67.16	4.83	2.18	5.09	1.74	53.22	17.05	0.29
lxvii)	ALU150 × 80 × 12.0	7.15	26.47	12.0	5.30	1.84	610.41	123.50	655.43	78.48	4.80	2.16	4.98	1.72	62.94	20.06	0.29
lxviii)	ALU200 × 100 × 10.0	7.98	29.55	16.0	6.95	2.04	1 245.12	217.90	1 322.87	140.15	6.49	2.72	6.69	2.18	95.38	27.37	0.27
lxix)	ALU200 × 100 × 12.0	9.48	35.11	16.0	7.04	2.12	1 466.07	254.59	1 556.66	163.99	6.46	2.69	6.66	2.16	113.13	32.30	0.26
lxx)	ALU200 × 100 × 16.0	12.42	45.99	16.0	7.22	2.28	1 886.05	322.58	1 999.02	209.61	6.40	2.65	6.59	2.13	147.52	41.76	0.26

*Based on density of 2.7 gm/cm³

Table 2 (Concluded)

SI No.	Designation and Size	Mass* per Metre	Sectional Area	Radius at Root	Centre of Gravity		Moment of Inertia				Radius of Gyration				Modulus of Section		Tan α
					C_z	C_y	I_z	I_y	I_u Max	I_v Min	r_z	r_y	r_u Max	r_v Min	Z_z	Z_y	
	(A × B × t, in mm)	(M)	(a)	mm	cm	cm	cm ⁴	cm ⁴	cm ⁴	cm ⁴	cm	cm	cm	cm	cm ³	cm ³	
(1)	(2)	(3)	(4)	(5)	(6)	(6)	(7)	(8)	(9)	(10)	(11)	(12)	(13)	(14)	(15)	(16)	(17)
lxxi)	ALU200 × 150 × 12.0	11.10	41.11	16.0	6.10	3.63	1 679.35	819.32	2 059.03	439.65	6.39	4.46	7.08	3.27	120.82	72.09	0.55
lxxii)	ALU200 × 150 × 16.0	14.58	51.99	16.0	6.26	3.79	2 168.22	1 051.71	2 653.96	565.97	6.34	4.41	7.01	3.24	157.86	93.82	0.55
lxxiii)	ALU200 × 150 × 20.0	18.05	66.86	20.0	6.40	3.94	2 632.10	1 267.91	3 210.76	689.24	6.27	4.35	6.93	3.21	193.58	114.59	0.55

*Based on density of 2.7 gm/cm³

Table 3 Indian Standard Aluminium Channels

(Clauses 4.1, 6.1 and 6.1.1)

SI No.	Designation	Mass* per Metre	Sectional Area	Depth of Section	Width of Flange	Thickness of Web	Thickness of Flange	Radius at Root	Centre of Gravity	Moment of Inertia		Radius of Gyration		Modulus of Section	
										I_z	I_y	r_z	r_y	Z_z	Z_y
		(M)	(a)	h	b	t_w	t_f	r	C_y	I_z	I_y	r_z	r_y	Z_z	Z_y
		kg/m	cm ²	mm	mm	mm	mm	mm	cm	cm ⁴	cm ⁴	cm	cm	cm ³	cm ³
(1)	(2)	(3)	(4)	(5)	(6)	(7)	(8)	(9)	(10)	(11)	(12)	(13)	(14)	(15)	(16)
i)	ALC 40 × 20 - 0.44	0.44	1.63	40	20	2.0	2.0	5.0	0.56	3.98	0.58	1.56	0.60	1.99	0.40
ii)	ALC 40 × 20 - 0.63	0.63	2.33	40	20	3.0	3.0	5.0	0.60	5.37	0.81	1.52	0.59	2.69	0.58
iii)	ALC 50 × 30 - 0.88	0.88	3.27	50	30	3.0	3.0	6.0	0.91	12.75	2.79	1.97	0.92	5.10	1.33
iv)	ALC 50 × 30 - 1.14	1.14	4.23	50	30	4.0	4.0	6.0	0.95	15.80	3.52	1.93	0.91	6.32	1.72
v)	ALC 60 × 30 - 1.33	1.13	4.17	60	30	3.0	4.0	7.0	0.94	23.62	3.59	2.38	0.93	7.87	1.75
vi)	ALC 60 × 30 - 1.55	1.55	5.73	60	30	4.0	6.0	7.0	1.03	31.10	4.89	2.33	0.92	10.37	2.48
vii)	ALC 60 × 30 - 1.69	1.69	6.24	60	30	5.0	6.0	7.0	0.98	32.2	5.03	2.27	0.89	10.7	2.50
viii)	ALC 60 × 30 - 1.95	1.95	7.21	60	30	5.0	8.0	7.0	1.09	37.14	6.05	2.27	0.92	12.39	3.17
ix)	ALC 60 × 40 - 1.87	1.87	6.93	60	40	4.0	6.0	7.0	1.46	39.88	11.05	2.90	1.26	13.29	4.35
x)	ALC 60 × 40 - 2.38	2.98	8.81	60	40	5.0	8.0	7.0	1.53	48.04	13.76	2.84	1.25	16.01	5.57
xi)	ALC 80 × 35 - 2.29	2.29	8.44	80	35	4.0	5.0	7.0	1.13	79.8	9.57	3.08	1.06	20.0	4.04
xii)	ALC 80 × 40 - 2.10	2.10	7.79	80	40	4.0	6.0	8.0	1.32	79.19	12.22	3.19	1.25	19.80	4.56
xiii)	ALC 80 × 40 - 2.67	2.67	9.87	80	40	5.0	8.0	8.0	1.40	96.72	15.28	3.13	1.24	24.18	5.87
xiv)	ALC 80 × 40 - 3.21	3.21	11.87	80	40	6.0	10.0	8.0	1.46	111.67	18.09	3.07	1.23	27.91	7.11
xv)	ALC 100 × 40 - 2.95	2.95	10.95	100	40	5.0	8.0	9.0	1.29	166.03	16.52	3.89	1.23	33.21	6.09
xvi)	ALC 100 × 40 - 3.20	3.20	11.8	100	40	6.0	8.0	9.0	1.24	171	16.9	3.81	1.19	34.2	6.12
xvii)	ALC 100 × 40 - 3.55	3.55	13.15	100	40	6.0	10.0	9.0	1.35	193.29	19.60	3.83	1.22	38.66	7.39

*Based on density of 2.7 g/cm³.

Table 3 (Continued)

SI No.	Designation	Mass* per Metre	Sectional Area	Depth of Section	Width of Flange	Thickness of Web	Thickness of Flange	Radius at Root	Centre of Gravity	Moment of Inertia		Radius of Gyration		Modulus of Section	
										I_z	I_y	r_z	r_y	Z_z	Z_y
		(M)	(a)	h	b	t_w	t_f	r	C_y	I_z	I_y	r_z	r_y	Z_z	Z_y
		kg/m	cm ²	mm	mm	mm	mm	mm	cm	cm ⁴	cm ⁴	cm	cm	cm ³	cm ³
(1)	(2)	(3)	(4)	(5)	(6)	(7)	(8)	(9)	(10)	(11)	(12)	(13)	(14)	(15)	(16)
xviii)	ALC 100 × 50 - 3.39	3.39	12.55	100	50	5.0	8.0	9.0	1.70	199.97	31.06	3.99	1.57	39.99	9.40
xix)	ALC 100 × 50 - 4.09	4.09	15.15	100	50	6.0	10.0	9.0	1.76	233.96	37.01	3.93	1.56	46.79	11.44
xx)	ALC 100 × 50 - 4.98	4.98	18.43	100	50	8.0	12.0	9.0	1.78	267.54	43.34	3.18	1.53	53.51	13.46
xxi)	ALC 120 × 50 - 3.68	3.68	13.63	120	50	5.0	8.0	10.0	1.59	308.82	33.07	4.76	1.56	51.47	9.69
xxii)	ALC 120 × 50 - 4.19	4.19	15.5	120	50	6.0	9.0	10.0	1.59	339	36.8	4.68	1.54	56.5	10.8
xxiii)	ALC 120 × 50 - 4.43	4.43	16.43	120	50	6.0	10.0	10.0	1.65	363.14	39.48	4.70	1.55	60.52	11.80
xxiv)	ALC 120 × 60 - 4.98	4.98	18.43	120	60	6.0	10.0	10.0	2.07	423.81	66.04	4.80	1.89	70.63	16.80
xxv)	ALC 120 × 60 - 6.08	6.08	22.51	120	60	8.0	12.0	10.0	2.08	489.62	77.97	4.66	1.86	81.60	19.87
xxvi)	ALC 140 × 60 - 5.66	5.66	20.9	140	60	7.0	10.0	12.0	1.89	625	71.5	5.47	1.85	89.2	17.4
xxvii)	ALC 150 × 60 - 5.51	5.51	20.42	150	60	6.0	10.0	12.0	1.90	722.88	71.41	5.95	1.87	96.38	17.43
xxviii)	ALC 150 × 60 - 6.77	6.77	25.10	150	60	8.0	12.0	12.0	1.91	843.19	84.30	5.80	1.83	112.42	20.60
xxix)	ALC 150 × 80 - 6.59	6.59	24.42	150	80	6.0	10.0	12.0	2.74	919.22	159.60	6.14	2.56	122.56	30.34
xxx)	ALC 150 × 80 - 8.07	8.07	29.90	150	80	8.0	12.0	12.0	2.73	072.29	190.37	5.99	2.52	142.97	36.09
xxxii)	ALC 150 × 80 - 10.26	10.26	38.02	150	80	10.0	16.0	12.0	2.87	311.20	233.10	5.87	2.50	174.83	46.41
xxxiii)	ALC 160 × 70 - 6.58	6.58	24.3	160	70	7.0	10.0	16.0	2.18	970	116	6.32	2.18	121	24.0
xxxiii)	ALC 180 × 75 - 8.06	8.06	29.8	180	75	8.0	11.0	16.0	2.27	1480	159	7.05	2.31	164	30.5

*Based on density of 2.7 g/cm³.

Table 3 (Concluded)

SI No.	Designation	Mass* per Metre	Sectional Area	Depth of Section	Width of Flange	Thickness of Web	Thickness of Flange	Radius at Root	Centre of Gravity	Moment of Inertia		Radius of Gyration		Modulus of Section	
										I_z	I_y	r_z	r_y	Z_z	Z_y
		(M)	(a)	h	b	t_w	t_f	r	C_y	I_z	I_y	r_z	r_y	Z_z	Z_y
		kg/m	cm ²	mm	mm	mm	mm	mm	cm	cm ⁴	cm ⁴	cm	cm	cm ³	cm ³
(1)	(2)	(3)	(4)	(5)	(6)	(7)	(8)	(9)	(10)	(11)	(12)	(13)	(14)	(15)	(16)
xxxiv)	ALC 200 × 80 - 9.19	9.19	33.9	200	80	8.0	12.0	16.0	2.45	2110	210	7.88	2.49	211	37.8
xxxv)	ALC 200 × 80 - 9.28	9.28	34.38	200	80	8.0	12.0	16.0	2.43	140.69	210.38	7.89	2.47	214.07	37.80
xxxvi)	ALC 200 × 80 - 11.74	11.74	43.50	200	80	10.0	16.0	16.0	2.58	638.55	268.98	7.79	2.46	263.86	48.72
xxxvii)	ALC 200 × 100 - 13.47	13.47	49.90	200	100	10.0	16.0	16.0	3.40	181.61	495.96	7.99	3.15	318.16	75.20
xxxviii)	ALC 200 × 100 - 15.33	15.33	56.78	200	100	12.0	18.0	18.0	3.41	499.65	552.64	7.85	3.12	349.97	83.84
xxxix)	ALC 240 × 100 - 12.5	12.5	46.0	240	100	9.0	13.0	18.0	3.03	4170	450	9.52	3.12	345	64.65

*Based on density of 2.7 g/cm³.

Table 4 Indian Standard Aluminium I-Beams

(Clauses 4.1, 6.1 and 6.1.1)

Sl No.	Designation	Mass*	Sectional Area	Depth of Beam	Width of Flange	Thickness of Web	Thickness of Flange	Radius at Root	Moment of Inertia		Radius of Gyration		Modulus of Section		Torsion Constant							
		(M)							(a)	(h)	(b)	(t _w)	(t _f)	(r)		I _z	I _y	r _z	r _y	Z _z	Z _y	(k)
		kg/m							cm ²	mm	mm	mm	mm	mm		cm ⁴	cm ⁴	cm	cm	cm ³	cm ³	cm ⁴
(1)	(2)	(3)	(4)	(5)	(6)	(7)	(8)	(9)	(10)	(11)	(12)	(13)	(14)	(15)	(16)							
i)	ALC 40 × 20-0.4	0.4	1.66	40	20	2.0	2.0	4.0	0.3	1.57	0.41	2.0	0.3	0.039	0.039							
ii)	ALC 40 × 20 - 0.6	0.6	2.36	40	20	3.0	3.0	4.0	0.4	1.52	0.42	2.7	0.4	0.104	0.104							
iii)	ALC 50 × 30 - 0.9	0.88	3.33	50	30	3.0	3.0	5.0	1.4	1.98	0.064	5.2	0.9	0.154	0.154							
iv)	ALC 50 × 30 - 1.2	1.14	4.29	50	30	4.0	4.0	5.0	1.8	1.93	0.66	6.4	1.2	0.322	0.322							
v)	ALC 60 × 30 - 1.1	1.2	4.17	60	30	3.0	4.0	5.0	1.8	2.38	0.66	7.9	1.2	0.252	0.252							
vi)	ALC 60 × 30 - 1.5	1.5	5.73	60	30	4.0	6.0	5.0	2.7	2.33	0.69	10.4	1.8	0.824	0.824							
vii)	ALC 60 × 30 - 1.9	1.9	7.21	60	30	5.0	8.0	5.0	3.7	2.27	0.71	12.4	2.5	1.700	1.700							
viii)	ALC 60 × 40-1.9	1.9	7.03	60	40	4.0	6.0	6.0	6.5	2.40	0.96	13.5	3.2	0.897	0.897							
ix)	ALC 60 × 40 - 2.4	2.4	8.91	60	40	5.0	8.0	6.0	8.6	2.33	0.98	16.2	4.3	1.97	1.97							
x)	ALC 80 × 40 - 2.1	2.1	7.83	80	40	4.0	6.0	6.0	6.5	3.19	0.91	19.9	3.2	0.940	0.940							
xi)	ALC 80 × 40 - 2.5	2.5	9.38	80	40	5.0	7.0	6.0	91.6	7.63	3.12	0.90	22.9	3.82	1.69							
xii)	ALC 80 × 40 - 2.7	2.7	9.91	80	40	5.0	8.0	6.0	8.6	3.13	0.93	24.3	4.3	1.97	1.99							
xiii)	ALC 80 × 40 - 3.2	3.2	11.91	80	40	6.0	6.0	6.0	10.8	3.07	0.95	28.0	5.4	3.63	3.63							
xiv)	ALC 100 × 50 - 3.4	3.4	12.62	100	50	5.0	8.0	7.0	16.8	3.99	1.15	40.3	6.7	2.55	2.55							
xv)	ALC 100 × 50 - 3.7	3.7	13.7	100	50	6.0	8.0	7.0	210	17.0	3.92	1.11	42.1	6.80	3.30							

*Based on density of 2.7 g/cm³.

Table 4 (Continued)

Sl No.	Designation	Mass*	Sectional Area	Depth of Beam	Width of Flange	Thickness of Web	Thickness of Flange	Radius at Root	Moment of Inertia		Radius of Gyration		Modulus of Section		Torsion Constant							
		(M)							(a)	<i>h</i>	<i>b</i>	<i>t_w</i>	<i>t_f</i>	<i>r</i>		<i>I_z</i>	<i>I_y</i>	<i>r_z</i>	<i>r_y</i>	<i>Z_z</i>	<i>Z_y</i>	<i>k</i>
		kg/m							cm ²	mm	mm	mm	mm	mm		cm ⁴	cm ⁴	cm	cm	cm ³	cm ³	cm ⁴
xvi)	ALC 100 × 50 - 3.9	3.9	14.42	100	50	5.0	10.0	7.0	21.0	4.00	1.21	46.2	8.4	4.27	4.27							
xvii)	ALC 100 × 60 - 3.9	3.9	14.35	100	60	5.0	8.0	8.0	29.0	4.07	1.42	47.4	9.7	3.05	3.05							
xviii)	ALC 100 × 60 - 4.1	4.1	15.19	100	60	6.0	10.0	8.0	29.1	3.99	1.38	48.4	9.7	3.43	3.43							
xix)	ALC 100 × 60 - 4.7	4.7	17.35	100	60	6.0	8.0	8.0	36.3	4.00	1.45	55.5	12.1	3.54	3.54							
xx)	ALC 120 × 60 - 4.7	4.7	17.55	120	60	5.0	8.0	8.0	36.2	4.88	1.44	69.7	12.1	5.47	5.47							
xxi)	ALC 120 × 60-5.0	5.0	18.70	120	60	6.0	10.0	9.0	36.4	4.80	1.39	71.7	12.1	5.95	5.95							
xxii)	ALC 120 × 70 - 5.6	5.6	20.70	120	70	6.0	10.0	9.0	57.5	4.87	1.67	81.8	16.4	6.62	6.62							
xxiii)	ALC 120 × 80 - 6.1	6.1	22.70	120	80	6.0	10.0	9.0	85.7	4.96	1.94	91.9	21.4	7.28	7.28							
xxiv)	ALC 120 × 80 - 7.4	7.4	27.58	120	80	8.0	12.0	9.0	103.1	4.30	1.93	106.0	25.8	12.8	12.8							
xxv)	ALC 140 × 70 - 6.3	6.3	23.4	140	70	7.0	10.0	9.0	725	57.9	5.57	1.57	104	16.5	8.00							
xxvi)	ALC 150 × 80 - 6.6	6.6	24.50	150	80	6.0	10.0	9.0	85.8	6.14	1.87	123.0	21.4	7.50	7.50							
xxvii)	ALC 150 × 80 - 8.1	8.1	29.98	150	80	8.0	12.0	9.0	103.2	5.99	1.86	143.4	25.8	13.3	13.3							
xxviii)	ALC 150 × 100 - 7.7	7.7	28.66	150	100	6.0	10.0	10.0	167.2	6.27	2.42	150.0	33.4	9.14	9.14							
xxix)	ALC 150 × 100 - 9.4	9.4	34.94	150	100	8.0	12.0	10.0	200.9	6.12	2.40	174.7	40.2	16.1	16.1							
xxx)	ALC 150 × 100 - 12.1	12.1	44.66	150	100	10.0	16.0	10.0	268.1	6.00	2.45	214.4	53.6	35.3	35.3							

*Based on density of 2.7 g/cm³.

Table 4 (Concluded)

Sl No.	Designation	Mass*	Sectional Area	Depth of Beam	Width of Flange	Thickness of Web	Thickness of Flange	Radius at Root	Moment of Inertia		Radius of Gyration		Modulus of Section		Torsion Constant							
		(M)							(a)	<i>h</i>	<i>b</i>	<i>t_w</i>	<i>t_f</i>	<i>r</i>		<i>I_z</i>	<i>I_y</i>	<i>r_z</i>	<i>r_y</i>	<i>Z_z</i>	<i>Z_y</i>	<i>k</i>
		kg/m							cm ²	mm	mm	mm	mm	mm		cm ⁴	cm ⁴	cm	cm	cm ³	cm ³	cm ⁴
xxxii)	ALC 160 × 80 - 7.6	7.6	28.2	160	80	7.0	11.0	10.0	117.0	94.6	6.45	1.83	147	23.7	10.8							
xxxiii)	ALC 200 × 100 - 10.5	10.5	38.94	200	100	8.0	12.0	10.0	201.1	8.09	2.27	255.0	40.2	16.9	16.9							
xxxiiii)	ALC 200 × 100 - 13.4	13.4	49.66	200	100	10.0	16.0	10.0	268.5	7.99	2.33	316.8	53.7	36.9	36.9							
xxxv)	ALC 200 × 120 - 12.9	12.9	47.64	200	120	10.0	12.0	12.0	347.9	8.06	2.70	309.3	58.0	24.1	24.1							
xxxvi)	ALC 200 × 120 - 16.1	16.1	59.80	200	120	12.0	16.0	12.0	464.2	7.99	2.79	381.4	77.4	49.6	49.6							

*Based on density of 2.7 g/cm³.

5 DESIGNATION

5.1 Aluminium equal leg angles sections shall be designated as ALE followed by lengths of legs and thickness of the section in mm.

Example:

ALE 80 × 80 × 6

5.2 Aluminium unequal leg angle sections shall be designated as ALU followed by lengths of the longer and shorter legs and thickness of the section in mm.

Example:

ALU 80 × 60 × 6

5.3 Aluminium channels shall be designated as ALC followed by the depth of channel in mm, flange width in mm and mass of the section in kg/m.

Example:

ALC 80 × 40 - 3.21

5.4 Aluminium I-beam sections shall be designated as ALB followed by the depth of the section, width of flange in millimetres and mass in kilograms per metre of the section.

Example:

ALB 120 × 60 - 4.7

6 DIMENSIONS AND SECTIONAL PROPERTIES

6.1 Dimensions and mass of Indian Standard aluminium sections shall be as given in [Table 1](#) to [Table 4](#). For convenience of reference sectional properties are also given in the tables.

6.1.1 Sections of dimensions other than those included in the [Table 1](#) to [Table 4](#) may also be manufactured subject to the agreement between the purchaser and the manufacturer.

6.1.2 Sections without root radius (square fillet) may also be manufactured subject to the agreement between the purchaser and the manufacturer.

6.2 Dimensional tolerances for the sections shall be as specified in IS 3965.

7 MATERIALS

7.1 Aluminium sections covered in this standard shall be manufactured from the following alloys in appropriate temper:

19 000, 24 345, 24 534, 52 000, 53 000, 54 300, 63 400, 64 423, 64 430, 65 032 and 74 530

Aluminium alloys and temper selected shall conform to the provisions of IS 733.

7.2 Other alloys and temper as per IS 733, as mutually agreed between purchaser and manufacturer, may also be used.

8 PACKING

Aluminium sections that are covered under this standard shall be securely bundled and wrapped in bituminised hessian cloth or in wooden boxes or as mutually agreed. Weight of each bundle may be as agreed to between the purchaser and the manufacturer.

9 MARKING

9.1 Each lot/bundle of aluminium section shall be clearly marked with designation, alloy and temper, manufacturer's name and lot number/year of manufacture.

9.2 BIS Certification Marking

The product(s) conforming to the requirements of this standard may be certified as per the conformity assessment schemes under the provisions of the *Bureau of Indian Standards Act, 2016* and the Rules and Regulations framed thereunder, and the products may be marked with the Standard Mark.

ANNEX A

(Foreword)

COMMITTEE COMPOSITION

Structural Engineering Sectional Committee, CED 07

<i>Organization</i>	<i>Representative(s)</i>
In Personal Capacity (<i>II, 2A, Rani Meyyammai Towers MRC Nagar, R A Puram, Chennai</i>)	DR V. KALYANARAMAN (Chairperson)
Ashwathnarayana & Eswara, Chennai	SHRI H. E. SRIPRAKASH SHASTRY
Bhilai Institute of Technology, Durg	DR MOHAN KUMAR GUPTA
Central Electricity Authority, New Delhi	SHRI A. K. JAIN DIRECTOR (TRANSMISSION) (<i>Alternate</i>)
Central Public Works Department, New Delhi	SHRI D. K. GARG SHRI N. K. BANSAL (<i>Alternate</i>)
Construma Consultancy Pvt Limited, Mumbai	DR HARSHAVARDHAN SUBBARAO
C.R. Narayana Rao, Architects & Engineers, Chennai	DR C. N. SRINIVASAN SHRI C. R. ARVIND (<i>Alternate</i>)
CSIR - Structural Engineering Research Centre, Chennai	DR G. S. PALANI DR NAPA PRASAD RAO (<i>Alternate I</i>) DR R. BALAGOPAL (<i>Alternate II</i>)
Engineers India Limited, New Delhi	SHRI ANURAG SINHA DR SUDIP PAUL (<i>Alternate</i>)
GAIL India Ltd, New Delhi	SHRI S. ASHISH VAIDYA
Indian Institute of Engineering Science and Technology, Shibpur	DR SUBRATA CHACKRABORTY MS CHAITALI RAY (<i>Alternate</i>)
Indian Institute of Technology Delhi, New Delhi	DR DIPTI RANJAN SAHOO DR ALOK MADAN (<i>Alternate</i>)
Institute for Steel Development & Growth, Kolkata	SHRI ARIJIT GUHA SHRI LAKHAMANA RAO PYDI (<i>Alternate</i>)
Jindal Steel & Power Ltd, Gurugram	SHRI SANJAY NANDANWAR
Larsen & Toubro Limited, Chennai	SHRI T. VENKATESH RAO
MECON Limited, Ranchi	SHRI B. K. PANDEY SHRI J. K. SARKAR (<i>Alternate</i>)
M. N. Dastur & Company Pvt Limited, Kolkata	SHRI SHUVENDU CHATTOPADHYAY SHRI GARGI ADITYA BASU (<i>Alternate I</i>) SHRIMATI MOHUA CHATTERJEE (<i>Alternate II</i>)
NTPC Ltd, Noida	SHRI HIMANSHU KUNDU SHRI CHANDER SHEKHAR (<i>Alternate</i>)

<i>Organization</i>	<i>Representative(s)</i>
Powergrid Corporation of India Limited, New Delhi	SHRI ABHISHEK MS SUMANA MUKHERJEE (<i>Alternate</i>)
Ramboll India, Hyderabad	SHRI D. SANKAR GANESH
Salasar Techno Engg Limited, Noida	SHRI DAYANAND K.
Steel Authority of India Limited, Ranchi	SHRI GAUTAM KUMAR MITRA SHRI DEEPAK RANGARAO (<i>Alternate</i>)
STUP Consultants Pvt Ltd, Kolkata	SHRI ANIRBAN SENGUPTA SHRI SUMANTRA SENGUPTA (<i>Alternate I</i>) SHRI MANDAR SARDESAI (<i>Alternate II</i>)
Takalkar Power Engineering and Consultants Private Limited, Vadodara	SHRI S. M. TAKALKAR SHRI SHREEDHAR V. RANA (<i>Alternate</i>)
Tata Consulting Engineers Ltd, Mumbai	SHRI PRATIP BHATTACHARYA SHRI T. SHRIPRASAD (<i>Alternate</i>)
The Institution of Engineers (India), Kolkata	SHRI S. H. JAIN
In Personal Capacity (<i>C-401, Greenfield Tower CHS, Kadamwadi, Vakola Santacruz (East), Mumbai</i>)	SHRI V. N. HEGGADE
In Personal Capacity (<i>Plot No. 686/2884, Shantinagar, Canal Road, Jharapada, Bhubaneswar</i>)	SHRI GYANA RANJAN MOHANTY
BIS Directorate General	SHRI DWAIPAYAN BHADRA, SCIENTIST 'E'/DIRECTOR AND HEAD (CIVIL ENGINEERING) [REPRESENTING DIRECTOR GENERAL (<i>Ex-officio</i>)]

Member Secretaries

SHRI ABHISHEK PAL
SCIENTIST 'D'/JOINT DIRECTOR

AND

SHRI DHEERAJ DAMACHYA
SCIENTIST 'B'/ASSISTANT DIRECTOR
(CIVIL ENGINEERING), BIS

Bureau of Indian Standards

BIS is a statutory institution established under the *Bureau of Indian Standards Act, 2016* to promote harmonious development of the activities of standardization, marking and quality certification of goods and attending to connected matters in the country.

Copyright

BIS has the copyright of all its publications. No part of these publications may be reproduced in any form without the prior permission in writing of BIS. This does not preclude the free use, in the course of implementing the standard, of necessary details, such as symbols and sizes, type or grade designations. Enquiries relating to copyright be addressed to the Head (Publication & Sales), BIS.

Review of Indian Standards

Amendments are issued to standards as the need arises on the basis of comments. Standards are also reviewed periodically; a standard along with amendments is reaffirmed when such review indicates that no changes are needed; if the review indicates that changes are needed, it is taken up for revision. Users of Indian Standards should ascertain that they are in possession of the latest amendments or edition by referring to the website-www.bis.gov.in or www.standardsbis.in.

This Indian Standard has been developed from Doc No.: CED 07 (22225).

Amendments Issued Since Publication

Amend No.	Date of Issue	Text Affected

BUREAU OF INDIAN STANDARDS

Headquarters:

Manak Bhavan, 9 Bahadur Shah Zafar Marg, New Delhi 110002

Telephones: 2323 0131, 2323 3375, 2323 9402

Website: www.bis.gov.in

Regional Offices:

	Telephones
Central : 601/A, Konnectus Tower -1, 6 th Floor, DMRC Building, Bhavbhuti Marg, New Delhi 110002	{ 2323 7617
Eastern : 8 th Floor, Plot No 7/7 & 7/8, CP Block, Sector V, Salt Lake, Kolkata, West Bengal 700091	{ 2367 0012 2320 9474
Northern : Plot No. 4-A, Sector 27-B, Madhya Marg, Chandigarh 160019	{ 265 9930
Southern : C.I.T. Campus, IV Cross Road, Taramani, Chennai 600113	{ 2254 1442 2254 1216
Western : 5 th Floor/MTNL CETTM Technology Street, Hiranandani Gardens, Powai, Mumbai - 400076	{ 25700030 25702715

Branches : AHMEDABAD, BENGALURU, BHOPAL, BHUBANESHWAR, CHANDIGARH, CHENNAI, COIMBATORE, DEHRADUN, DELHI, FARIDABAD, GHAZIABAD, GUWAHATI, HARYANA (CHANDIGARH), HUBLI, HYDERABAD, JAIPUR, JAMMU, JAMSHEDPUR, KOCHI, KOLKATA, LUCKNOW, MADURAI, MUMBAI, NAGPUR, NOIDA, PARWANOO, PATNA, PUNE, RAIPUR, RAJKOT, SURAT, VIJAYAWADA.