

Draft Indian Standard

**CODE OF PRACTICE FOR EXTERNAL FACINGS AND
VENEERS
PART II CEMENT CONCRETE FACING**

(First Reprint AUGUST 1990)

Draft Indian Standard

**CODE OF PRACTICE FOR EXTERNAL FACINGS AND
VENEERS
PART II CEMENT CONCRETE FACING**

0.FOREWORD

0.1 This Indian Standard (Part II) was adopted by the Indian Standards Institution on 30 March 1967, after the draft finalized by the Building Construction Practices Sectional Committee had been approved by the Civil Engineering Division Council.

0.2 Concrete slabs with different colours, textures and finishes provide possibilities for a wide range of architectural treatment for external facing and are particularly suited for wide scale adoption in multi-storey constructions. While finishes with natural materials like stone slabs are restricted by the availability of suitable stones and the dressing possible for facing, the concrete finishes can be made, in order to obtain a wide range of textures and colours. The manufacture and marketing of white cement in this country now has considerably expanded the applicability of concrete to facing work.

0.2.1 However, it may not be enough to make the concrete blocks and slabs in the same manner as for interior work since when exposed to action of weather, the dimensional changes are much more and concrete has got to be carefully designed to accommodate this. Specially made facing blocks or slabs are necessary for this purpose. The techniques of fixing concrete facing slabs also have made several advancements with regard to fixing devices and their arrangements, jointing mortar, etc, and their selection with regard to exposure conditions and also with regard to types of units with which they are used. Part II of this code is intended to provide guidance with regard to selection of materials and fixing techniques for facing with concrete slabs; Part I covers stone facing and only such techniques which are considered to be feasible for adoption in this country under the present conditions have been included.

0.3 In the formulation of this standard due weightage has been given to international co-ordination among the standards and practices prevailing in different countries in addition to relating it to the practices in the field in this country.

0.4 For the purpose of deciding whether a particular requirement of this standard is complied with, the final value, observed or calculated, expressing the result of a test or analysis, shall be rounded off in accordance with IS : 2-1960. The number of significant places retained in the rounded off value should be the same as that **of** the specified value in this standard.

Draft Indian Standard

~~CODE OF PRACTICE FOR EXTERNAL FACINGS AND VENEERS PART II CEMENT CONCRETE FACING~~

1 SCOPE

1.1 This standard (Part II) covers fixing of cement concrete facing which may be in the form of precast concrete facing blocks or slab units.

1.2 This standard does not cover the fixing of prefabricated panels of plaster rendering mosaic or terrazzo.

2 TERMINOLOGY

2.0 For the purpose of this standard, the following definitions shall apply.

2.1 Combing – The process of graining done with a flexible toothed metal plate.

2.2 Facing – Where different parts of the, wall thickness are composed of different materials or grades of materials, facing refers to the outer part of the wall, composed of one material or grade of material and held to the other part (backing) by bonding or mechanical anchors or both.

2.3 Hardening Shrinkage – The shrinkage that occurs in a freshly made precast concrete unit during the period of drying to maturity.

2.4 Joint Sealing Compound – A material used by itself or in conjunction with mortar or other material for making the joints watertight.

2.5 Mastic – A general term for any substance which remains pliable, used for adhesive compounds and joint sealing compounds.

2.6 Storey Level Support – The support given to facings at storey levels, **so** that there is not a tendency to continuous load transfer from the top facings of the building down to those at ground level.

3 NECESSARY INFORMATION

3.1 For the efficient planning, design and execution of external facing or veneering work, detailed information with regard to the following shall be furnished to those responsible for external facing and veneering work:

- a) Dimensional details of the walls to be faced or veneered; type and conditions of backing to which the facings are to be attached;
- b) The method of attachment, namely, whether the facing should be independently supported or may be attached rigidly to the backings;
- c) Location and details of openings, chases, drainage pipes, service lines, etc, to be embedded; and
- d) Any special precaution with regard to design which are to be taken into account depending upon the local climatic and other conditions.

3.2 All information shall be made available to those who are responsible for the facing work, necessary drawings and instructions for planning work shall also be furnished.

3.3 Arrangements shall also be made for the proper exchange of information between those engaged in facing work and all those whose work will effect or will be effected.

4 MATERIALS

4.1 Precast concrete facing concrete blocks shall conform generally to the requirements of IS : 2185-4-1 (2005),-2(1983),-3(1984),-4(2008) and in addition shall have special treatment in regard to durability, colour and surface textures for the exposed facing.

NOTE — Where the blocks are manufactured in a horizontal core machine a special face mix admixed with a waterproofing compound shall be cast integrally with the body of the block, both mixes having approximately the same moisture movement. Where the blocks are manufactured in a vertical core machine, combing marks are made on one face of the blocks after they are taken out of the mould end subsequently this face is treated with a special face mix admixed with a waterproofing compound. If the cost is not prohibitive, a richer mix admixed with a waterproofing compound may be used throughout in the facing blocks.

4.1.1 The size commonly adopted for concrete facing slabs will be 60 × 40 × 3 cm. The face finish of slabs shall also be adequately waterproofed.

4.1.2 For obtaining various colours in the admixtures, reference may be made to IS : 2114-1962(1984) in which information regarding the pigments to be used in concrete mixes are also covered, The textures and patterns that are obtainable in precast concrete blocks are innumerable and some of the popular patterns are the following:

- a) Chequered rubber mat,
- b) Corrugated surface,
- c) Two-colour chequered patterns,
- d) Multi-colour mosaic patterns, and
- e) Canvas texture.

4.1.2.1 Some of the well-known textures are the following:

- a) Smooth trowel finish,
- b) Wood float finish,
- c) Cork float finish,
- d) Scraped surface finish,
- e) Rubber sponge float finish,
- f) Sand surface face down finish (see also IS : 2402-1963).
- g) Pebble dash finish,
- h) Rough cast finish, and
- j) Cast-stone finish.

4.1.2.2 Further information about various finishes is given in IS : 2402-1963.

4.2 The material for cramps shall have high resistance to corrosion under conditions of dampness and against the chemical action of mortar or concrete in which cramps are usually embedded.

4.2.1 The cramps may be of copper, alloyed with zinc, tin, nickel and aluminium or stainless steel.

4.2.2 Aluminium alloy H 9 in W condition (see IS : 733-~~1956~~1983) may also be used for cramps.

4.3 Metal Angle Supports – Metal steel angles used for metal angle supports shall be clean of mill-scale and loose rust after fabrication and shall be given a protective coat preferably in the form of galvanizing. Or with at least two coats of appropriate paint as specified in IS : 1477 (Part I)-~~1959~~1971 and IS : 1477 (Part II)-~~1963~~1971. Non-corrosive brass angles will be preferable.

4.4 Mortar Materials

4.4.1 Cement – Cement used for making mortar for bedding joint shall be of ordinary Portland cement conforming to IS : 269-~~1958~~1989 or IS : 455-~~1962~~ 1989 or IS : 1489-~~1962~~ part 1(2015).

4.4.2 Sand – shall conform to IS : 2116-~~1965~~ 1980

4.4.3 Lime – shall conform to IS : 712-~~1964~~.1984

4.4.4 SURKHI – shall conform to IS : 1344-~~1959~~.1981

4.4.5 The water shall be clean and free from injurious amounts of deleterious materials.

5 DESIGN CONSIDERATIONS

5.1 Structural Design

5.1.1 The structural design of facings and their attachments must be able to withstand, without damaging the pushing and pulling effect of positive and negative air pressures got by winds. For design data with regard to wind loads reference may be made to IS : 875-1964.Part 1(1987),Part 2(1987),Part 3(2015),Part 4(1987),Part 5(1987)

5.1.2 In the case of cramp-supported facings, the stresses induced by weight of the facings shall also be considered in the design of the cramps or other attachments.

5.2 Types of Facing and Methods of Attachment – Facings and veneering may be of two types:

- a) Attached facings for use with backing only as a safe means of attachment without essentially contributing to the stability or load bearing properties of the wall, and
- b) Integrally reacting facings which are bonded with the backing and contribute to the structural stability and strength of the wall.

5.2.1 Methods of attachment of facings may be any one of the following:

- a) Using cramps to hold the facing units in position only, the weight of the unit being transferred to the facing unit beneath; or
- b) Using cramps to hold the units in position and in, addition to support the units thus transferring the weight of the unit to the backing; or
- c) The facing unit may contain projections which mechanically bond into the backing and support the unit; or
- d) By means of masonry bond or keying to the backing; or
- e) By combinations of the above methods.

5.2.2 Where cramps are used to hold the unit in position only, the facings shall be provided with a continuous support on which they rest at the ground level and other storey levels, the support being in the form of projection from or recess in the concrete floor slab, or a beam between the columns or a metal angle attached to the floor slab or beams. These supports shall preferably occur at vertical intervals not more than 3.5 m apart and also over the heads of all openings. Such supports shall also be provided where there is a transition from thin facings below the thicker facings fixed above.

NOTE — Generally the **weak** point about facing of high walls with low transmitting facing slabs will be the dependence of the whole upon the performance of each unit. The failure to hold a slab properly in position by accidental omission of a faulty cramp or a failure in an imperfect facing,

etc, may result in collapse of many facings above and around the point of failure. To obviate this risk intermediate supports for facings will be essential. However, the stresses set up in the lower most facings as a result of accumulation of the load will normally be of such an order that can be borne by the material.

5.2.3 Staggering – Staggering of vertical joints may also preferably be adopted to reduce the danger of wholesale collapse.

5.3 Supporting by Projecting – Supporting by means of projections which may mechanically bond into the facing is a common method of attaching concrete facing units. Projecting portions must be reinforced to prevent failures. In areas of severe exposure the reinforcement of the concrete shall have enough cover to minimize the risk of corrosion and section spoiling.

5.4 Supporting by Cramps - Facing blocks or slab units shall be supported by means of cramps for its stability. Cramps may be attached to its sides (see A and B in Fig. 1) or at top and bottom (see C, D, E and F in Fig. 1) or to its sides, top and bottom (see G and H in Fig. 1) or in its centre (see J in Fig. 1).

5.4.1 The position and number of cramps shall be fixed with regard to the facing type, size and weight of units and the condition of workmanship obtainable in the particular situation. The minimum number of cramps required for fixing facing unit to the wall are illustrated in Fig. 1. These minimum requirements should be modified in accordance with the situation.

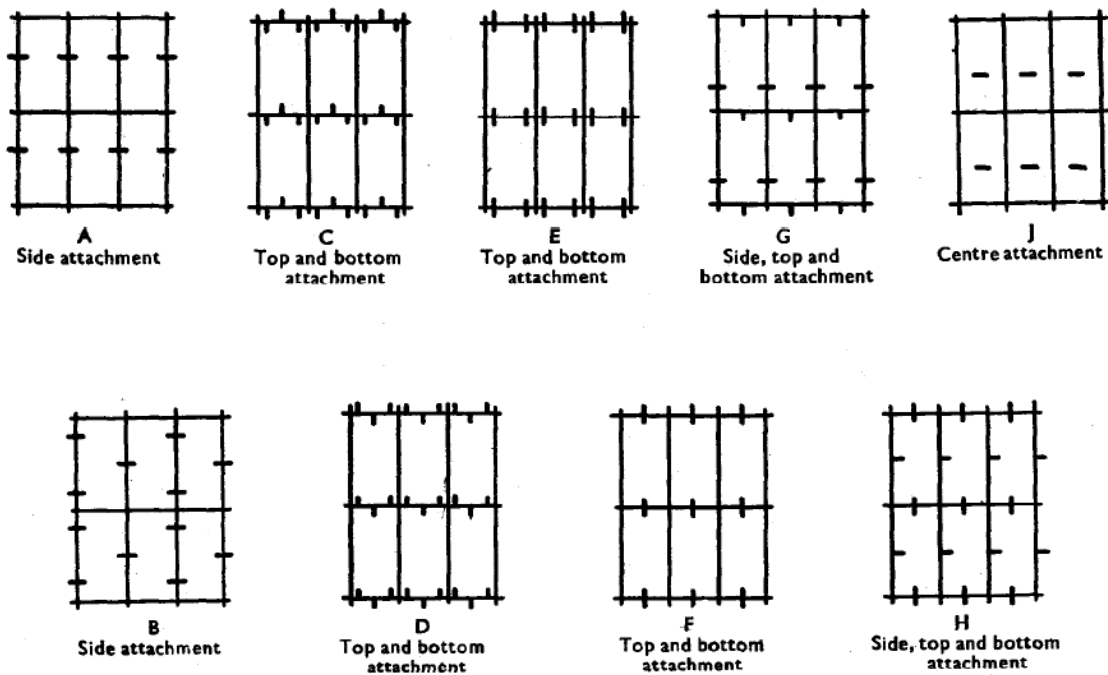

NOTE — Cramps shown in diagrams 'A-J' are arranged for facings with the longer sides vertical. For facings having the longer sides horizontal, cramps would be positioned to suit the altered proportions of the facings.

FIG. 1 DIAGRAMMATIC ARRANGEMENTS OF CRAMPS FOR ATTACHING FACINGS TO BACKING WALL

5.4.2 Side Attachment – For horizontal joints of double joggle or grouted core type one cramp shall be attached to the both sides of facing (see A in Fig. 1). Alternatively, two cramps shall be attached to one side of facing and one cramp to the other side (see B in Fig. 1).

5.4.3 Top and Bottom Attachment – Two cramps at top and one at bottom of facing shall be attached in case the bottom cramps are unsuitable for bearing load (see C in Fig. 1); where bottom cramps are in position to bear load, two cramps at bottom and one at top shall be attached (see D in Fig. 1). For making arrangement, more simpler, two double cramps shall be attached at bottom and top of the facing block (see E in Fig. 1). In case vertical joints are grouted and cramps carry no weight, two double cramps shall be attached one at bottom and the other at the top (see F in Fig. 1).

5.4.4 Side, Top and Bottom Attachment – Three cramps shall be attached to the facing block to have more security for holding; out of three, two shall be double cramps and one single cramp. Single cramp shall be attached at the top and double cramps shall be attached to both the sides (see G in Fig. 1). If single cramp is attached to its side and double cramps are attached to the top and bottom, the arrangement will be unsuitable for bearing load unless an extra cramp is fixed at horizontal joint (see H in Fig. 1).

5.4.5 Centre Attachment – One central holding cramp shall be suitable for horizontal joints of double joggle or grouted core type (see J in Fig. 1). This arrangement is only specified for precast materials.

5.5 Joints – The joints between facing units may be finished flush, tuck, ruled, square, weathered-struck or rebated, as in Fig. 2. Where expansion joints are formed in the general structure or backing walls, these joints shall also be carried through the facing.

5.5.1 To make the joints weather tight, normally composite mortar cement lime sand 1 : 1 : 6 will be found satisfactory.

NOTE — Special joint sealing compounds which have greater elasticity than masonry mortar and better durability are used in other countries but these compounds are not generally available in this country.

5.5.2 For prevention of travel of moisture from the backing to the facing where such trouble is envisaged, sometimes it may be useful to attach the facing unit with only dabs of mortar instead with application of mortar to the whole of the backing. However, this procedure will have disadvantages compared to solid filling, such as less protection against impact, tendency to warping and less security of cramp fixing.

5.5.3 Use of string courses or other features for deflecting water from the face of high buildings will considerably reduce the incidence of moisture penetration both at the

joints and at the facing unit. However, a vertical and horizontal joints around such features shall be properly sealed with a waterproofing compound.

NOTE - Generally bitumens of Grade 260 to 500 will be suitable for such sealing (see also IS : 1834-1964).1984

6 FIXING PRECAST CONCRETE SLAB FACINGS

6.1 The facings can be fixed with butt joints, single and double joggled joints or grouted joints as illustrated in Fig. 2, 3 and 4.

6.2 When the backing wall is of *in situ* concrete it will be of advantage to use dovetailed non-corrosive metal channels cast vertically in the backing wall in which one end of the cramps fit, the other end being cranked or drilled for dowells, the cramps being set into the channel as the fixing proceeds.

6.3 Precast Concrete Fixing System The precast concrete façade fixing system allows concrete façade slabs to be anchored to a supporting structure in a fast and simple way. It is designed for the secure and fast installation of prefabricated concrete panel on load bearing structure. The system consists of support and restraining elements. Parts associated are ,Upper in part, tension bar, lower part, Spacer bolt, bolt restrain.

Elevation and section of precast concrete fixing panels are placed in Fig.6.

Facing panel anchors .are shown in fig7.

6.4 Sandwich wall

Low weight and high structural rigidity have made the sandwich wall the most popular insulated precast concrete panels for facades. The sandwich panel consists of load bearing concrete ,inner layer and façade concrete layer with a rigid insulation layer. Sandwich wall elements shall be prepared horizontally on tables, door and window openings are added to the sandwich wall. The inner concrete layer is 80-150 mm and the outer 70-85mm. The sandwich panel thermal insulation shall be 150-220mm depending on the insulation type. Panel shall be used for the entire building envelope, including the exterior façade, Vapour barrier and insulation purpose. In figure 8 typical sandwich panel is shown. Carbon fibre grid is introduced in the sandwich panel. Figure 9 showing a section for fully composite connection system

6- 5 Use of Butt Joints

6.5.1 Butt joint is the simplest form of joints and may be used when the facing unit has a projection into a backing to provide mechanical bond.

6.3.52 It may also be used when it has no such projection with the following arrangements:

- a) The weight of the facing unit is transmitted to the facing unit under it and the facing unit is attached to the backing with mortar only (see A1 in Fig. 4).
- b) The weight of the facing units is transmitted to the facing unit below but the facing unit is attached to the backing by means of flat cramps and by mortar.

The split end of the cramp shall be fixed to the facing unit by making a groove in it (see A2 in Fig. 4).

- c) Part of the weight of the facing unit is transmitted directly to the backing by means of a rag bolt (see A3 in Fig. 4).

6.4 Single Joggled Joint – In the case of single joggled joints when side cramps are used they need only be single cramp as, one side of the cramp is already held in position. The positioning of single cramp will be easier than that of double cramps in practice (see B2 and B3 in Fig. 4). Where ledged type of facing is used in conjunction with an inverted single-joggle Joint, probably cramps may not be necessary and the joint shall be as shown in Fig. 5.

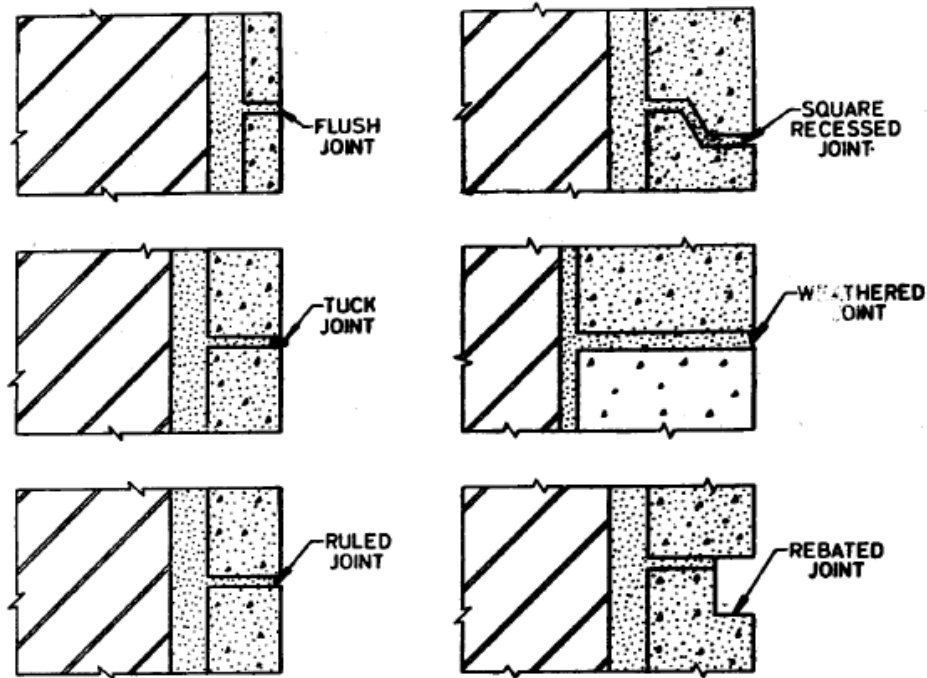
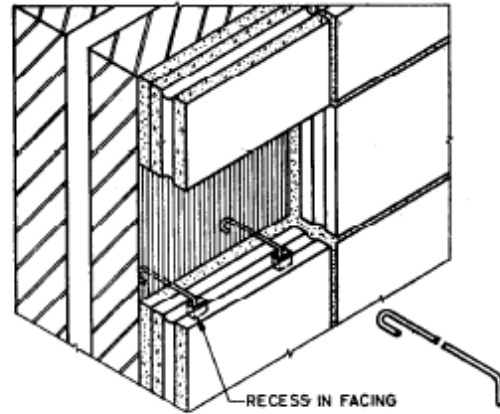
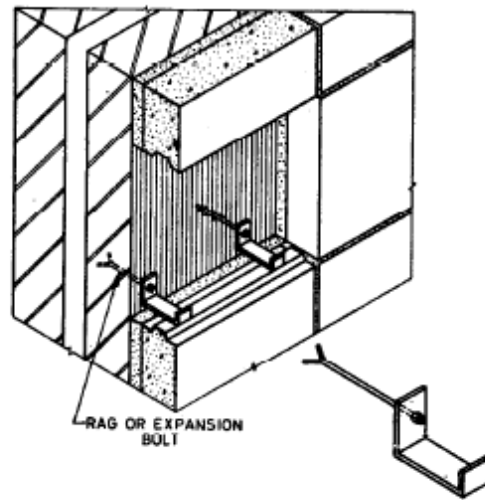

FIG. 2 TYPES OF FINISHES FOR JOINTS



3 A TYPICAL FIXING DETAIL OF CRAMP



3 B ALTERNATIVE FIXING DETAIL OF CRAMP

FIG 3 DETAILS OF CRAMP FOR PRECAST CONCRETE FACINGS – *Contd*

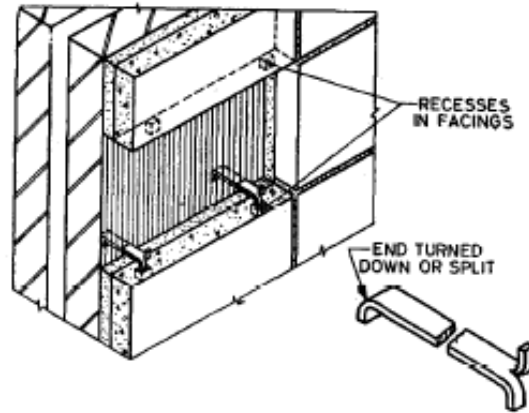

3C TYPICAL FIXING DETAIL OF CRAMP

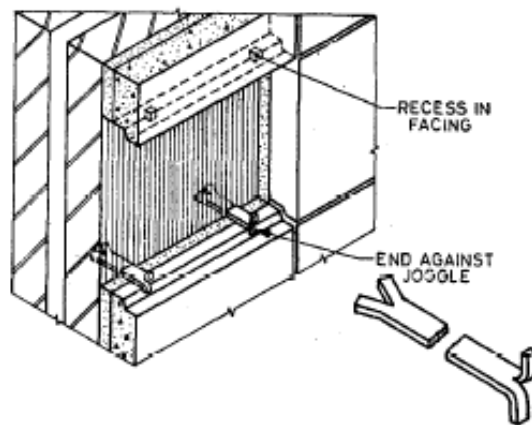

3D TYPICAL FIXING DETAIL OF CRAMP

FIG. 3 DETAILS OF CRAMP FOR PRECAST CONCRETE FACINGS

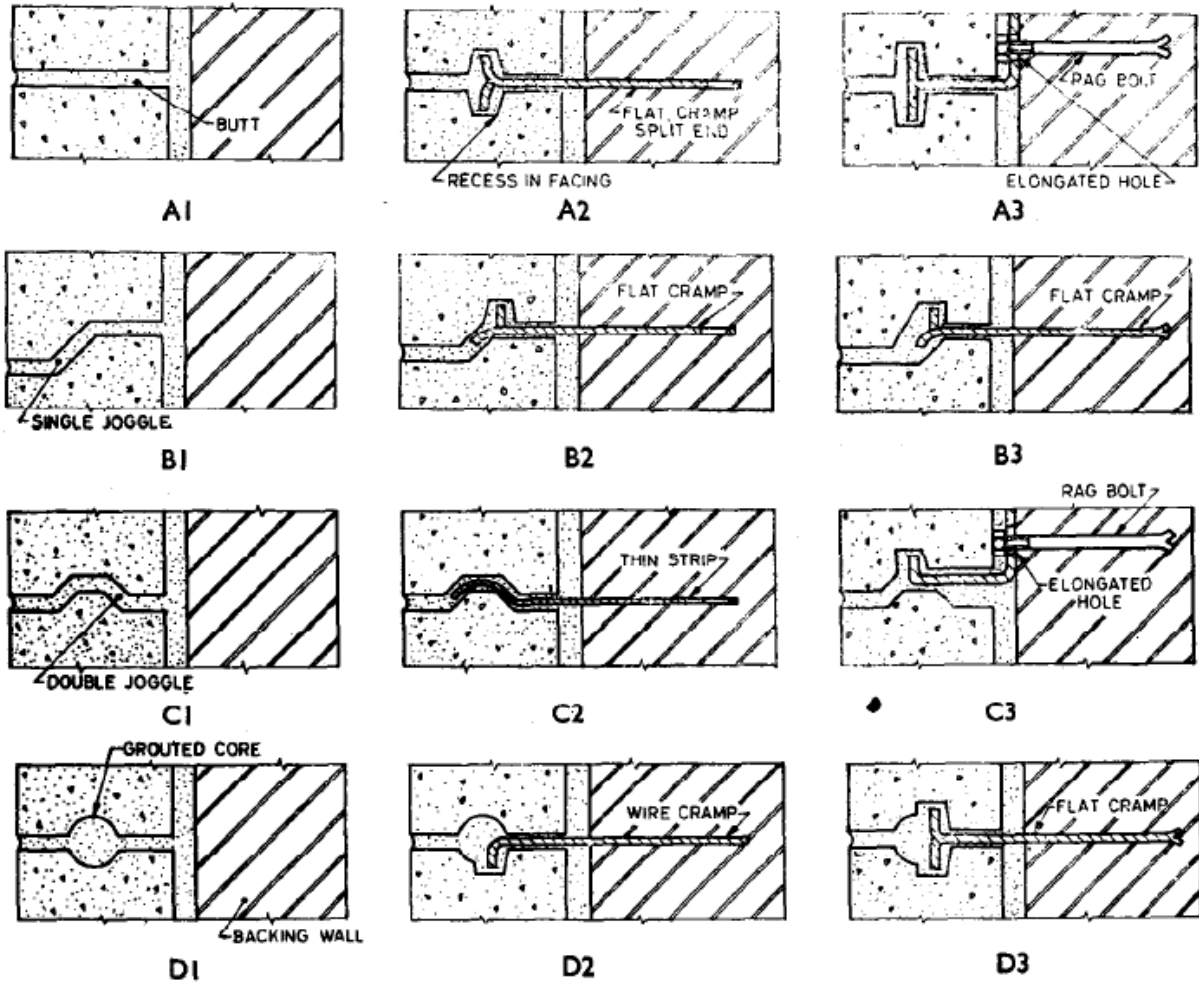
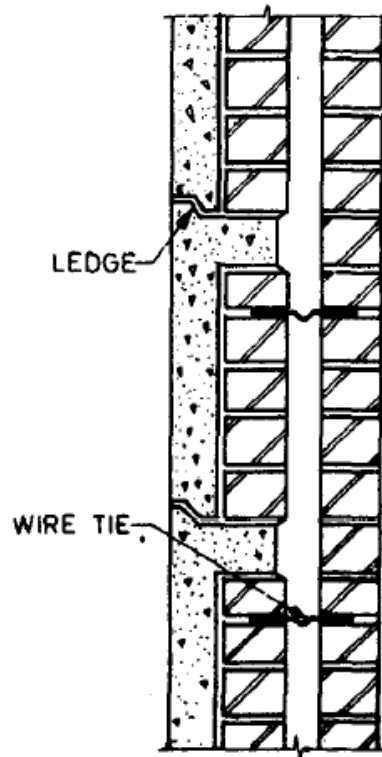

FIG. 4 PRECAST CONCRETE FACING CRAMP AND JOINT DETAILS



NOTE — The inverted joggle joint at the top of the ledge is suitable only when the joining is applied to a cavity wall.

FIG. 5 CONCRETE FACINGS SUPPORTED ON LEDGES

6.57 Double Joggled Joint – Double joggled joint (see C1 in Fig. 4) will not be suitable for vertical joints as the sliding action necessary to engage the unit vertically will interfere with the proper bedding of the horizontal joint and the bond to the backing wall mortar. This type of joint shall, however, be suitable for horizontal joints; it locks the units to one another by positive action, but cramps may be needed to hold the units to the wall as illustrated in C2 in Fig. 4. Cramps when fitted to the wall with the help of rag bolt as shown in C3 in Fig. 4 shall be in position to support the weight of construction at intermediate levels.

6.68 The grouted joint as shown in D1 in Fig. 4 shall stabilize the facing system if applied to all horizontal and vertical joints. When this type of joint is used horizontally care shall be taken to ensure that as much as possible the upper groove is filled with mortar. When using this type of joint as a vertical joint it may be advantageous to plank off or caulk the external portion of the joint up to the outer edge of the core with rolled paper. The joint shall be filled with cement sand grout and the rolled paper shall be extracted out when the grout has partially set and the joint shall be pointed immediately. Cramps may be used for supporting the unit with the wall and also for bearing load partially as in D2 and D3 in Fig. 4, respectively.

6.7 9 The thickness of joints may vary from 6 to 10 mm. Where necessary from architectural considerations, thickness of weathered joints may be more but shall never exceed 15 mm.

7 CONTROL OF ALIGNMENT

7.1 The appearance of the finished wall face exhibiting a plain surface will be easily marked by inaccuracies of alignment. Accuracy of alignment will depend upon the control of uniform size for the coverings, freedom from warping as well as in the accuracy with which the cramps are fixed. Where practicable the backing wall shall be built simultaneously with the fixing of facings as this will assist in maintaining the correct alignment of the facings. Inaccuracies in alignment of slabs to some extent will be masked by the treatment of the joints, for example, by the use of chamfered, slightly rounded or rebated edge in place of simple squared edge. Such an edge will in addition be free from chipping due to handling.