क्लोरोफॉर्म, शुद्ध और तकनीकी — विशिष्टि
(तीसरा पुनरीक्षण)

**Chloroform, Pure and Technical —
Specification**
(*Third Revision*)

ICS 71.080.20

© BIS 2024



भारतीय मानक ब्यूरो
BUREAU OF INDIAN STANDARDS
मानक भवन, 9 बहादुर शाह ज़फर मार्ग, नई दिल्ली - 110002
MANAK BHAVAN, 9 BAHADUR SHAH ZAFAR MARG
NEW DELHI - 110002

www.bis.gov.in www.standardsbis.in

FOREWORD

This Indian Standard (Third Revision) was adopted by the Bureau of Indian Standards, after the draft finalized by the Organic Chemicals, Alcohols and Allied Products Sectional Committee had been approved by the Petroleum, Coal and Related Products Division Council.

Chloroform, also known as trichloromethane is used as a solvent for waxes, fats, oils, rubber, resins, etc. Besides being a good solvent, it is used as a cleansing agent in fire extinguishers to lower the freezing temperature of carbon tetrachloride and for the manufacture of refrigerants of the chlorofluoro methane series. It is also used as an analytical reagent, as solvent and eluent.

The anesthetic properties of chloroform are well known, though due to its toxic effect, this use is being abandoned. On inhalation, it irritates the mucous membrane; prolonged inhalation will bring on paralysis which is often fatal. The requirements of chloroform for medical purposes are laid down in the Indian pharmacopoeia

This standard was originally published in 1969 and subsequently revised in 1979 and 1995. The first revision was taken up to incorporate the limits for moisture content and impurities like methyl chloride, methylene chloride and carbon tetrachloride along with their methods of test. The requirements for relative density and distillation range were also suitably modified with respect to the type of stabilizer used.

The second revision was taken up to update the requirement and modify the test method of distillation range. The requirement for colour was also introduced.

In this revision, the following changes have been taken place:

- a) Requirement of purity has been incorporated with limit of 99.5, percent by mass for pure grade and 98, percent by mass for technical grade, which is to be tested by gas chromatographic method;
- b) Gas chromatography method ([Annex K](#)) has been modified for better separation, low level detection and quantification of impurities and referred as test method for determination of purity;
- c) Since gas chromatography method is more authentic and accurate hence distillation range characteristics has been made optional parameter to be tested;
- d) Test method for free chlorine modified;
- e) Alternative test method for colour determination has been incorporated;
- f) Foreign organic matter test has been deleted as material is purely chemical synthesis and no biological origin material, stones, sands, lumps of soil are used in manufacturing of chloroform; and
- g) The limit for acidity for pure grade has been modified as 0.000 5.

The composition of the Committee, responsible for the formulation of this standard is given in [Annex P](#).

For the purpose of deciding whether a particular requirement of this standard is complied with the final value, observed or calculated, expressing the result of a test or analysis shall be rounded off in accordance with IS 2 : 2022 'Rules for rounding off numerical values (*second revision*)'. The number of significant places retained in the rounded off value should be the same as that of the specified value in this standard.

*Indian Standard***CHLOROFORM, PURE AND TECHNICAL — SPECIFICATION***(Third Revision)***1 SCOPE**

1.1 This standard prescribes the requirements and the methods of sampling and test for chloroform, pure and technical.

1.2 It does not cover pharmaceutical grade of the material.

a) Pure : Generally used for the manufacturing of refrigerants of the chlorofluoro methane series, and as an analytical reagent; and

b) Technical : For other industrial uses.

2 REFERENCES

The standards listed in [Annex A](#) below contain provisions, which through reference in this text constitute the provisions of this standard. At the time of publication, the editions indicated were valid. All standards are subject to revision, and parties to agreements based on this standard are encouraged to investigate the possibility of applying the most edition of these standards.

3 GRADES

3.1 There shall be two grades of the material, namely:

4 REQUIREMENTS**4.1 Description**

The material shall be highly refractive, non-flammable, heavy, very volatile, sweet-testing liquid with characteristic odour. It shall be miscible with alcohol, benzene, ether, carbon tetrachloride and carbon disulphide.

4.2 The material shall also comply with the requirements given in [Table 1](#) when tested according to the methods referred in col (5) of [Table 1](#).

Table 1 Requirements for Chloroform, Pure and Technical*(Clauses [4.2](#), [6.3.3](#), [C-3.2](#), [G-4.2](#) and [J-4.2](#))*

Sl No. (1)	Characteristic (2)	Requirement		Method of Test, Ref to/Indian Standards (5)
		Pure (3)	Technical (4)	
i)	Relative density ¹⁾ at 27°/27 °C	1.477 to 1.483	1.474 to 1.484	Annex B
ii)	Distillation range ²⁾ , the temperature being corrected to a pressure of 760 mmHg	The difference between the temperature (running points) at which 2 percent and 97 percent of the volume taken have been collected shall not exceed 1 °C and the range shall include the temperature of 61.3 °C	The difference between the (running points) at which 2 percent and 97 percent of the volume taken have been collected shall not exceed 2 °C and the range shall include the temperature of 61.3 °C	Annex C
iii)	Residue on evaporation/ Non-volatile matter, percent by mass, <i>Max</i>	0.002	0.010	Annex D
iv)	Free chlorine content	To pass the test	To pass the test	Annex E
v)	Acidity, percent by mass (as HCl), <i>Max</i>	0.000 5	0.02	Annex F
vi)	Aldehydes, percent by mass, <i>Max</i>	0.000 5	—	Annex G

Table 1 (Concluded)

SI No.	Characteristic	Requirement		Method of Test, Ref to/Indian Standards (5)
		Pure (3)	Technical (4)	
(1)	(2)			
vii)	Ketones, percent by mass, <i>Max</i>	0.005	—	Annex G
viii)	Phosgene content	To pass the test	—	Annex H
ix)	Chloride, percent by mass, <i>Max</i>	0.000 1	—	Annex J
x)	Moisture content, percent by mass, <i>Max</i>	0.01	—	Annex K
xi)	Methyl chloride, methylene chloride and carbon tetrachloride, percent by mass, <i>Max</i>	0.025	—	Annex L
xii)	Colour, Pt-Co units, <i>Max</i>	15	15	Annex M/ (IS 8768)
xiii)	Purity, percent by mass (excluding ethanol as a stabilizer), <i>Min</i>	99.5	98	Annex L

4.2.1 Specific Requirement

For the alcohol stabilized product, the requirements for relative density, distillation range and moisture content shall be as follows:

SI No.	Characteristics	Requirements	Method of Test, Ref to (4)
(1)	(2)	(3)	(4)
i)	Relative density at 27°C/27 °C	1.466 to 1.474	Annex B
ii)	Distillation range, (being temperature corrected to a pressure of 760 mmHg)	The difference between the temperatures (running points at which 2 percent and 97 percent of volume taken have been collected shall not exceed 2 °C and the range shall include the temperature of 61.3 °C).	Annex C
iii)	Moisture content, percent by mass, <i>Max</i>	0.05	Annex K

4.2.2 Quality of Reagents

Unless specified, otherwise, pure chemicals and distilled water (*see* 1070) shall be employed in tests.

NOTE — 'Pure chemicals' shall mean chemicals that do not contain impurities which affect the results of analysis.

4.3 A suitable stabilizer as agreed to between the supplier and the purchaser shall be added to the material. The maximum quantities of stabilizers recommended are as follows:

- a) Hydrocarbon stabilized material :
35 ppm ± 15 ppm.

- b) Alcohol stabilized material :
1.5 percent (*m/v*)

5 PRECAUTIONS IN HANDLING

Wear eye protection, face protection, protective clothing, protective gloves, mask and avoid direct inhalation. On inhalation or ingestion, it leads to narcosis, preceded by a stage of excitation, then follows loss of reflexes and consciousness. Hence, it should be handled carefully. If a person shows symptoms of chloroform poisoning, he should be immediately removed to fresh air, suitable first aid should be given and physician should be called.

¹⁾ The correction factor within the range of 25 °C to 35 °C is + 0.001 8 for every degree celsius fall and - 0.001 8 for every degree celsius rise in temperature.

²⁾ Distillation range is an optional requirement to be tested.

³⁾ In case of disputes, IS 8768 shall be the referee method.

6 PACKING, STORING AND MARKING

6.1 Packing

The material shall be packed as agreed to between the supplier and the purchaser. The packing generally used is described below:

- a) Pure grade of material used for analytical purposes shall be packed in amber-coloured glass bottles, with well-fitting stoppers and non-reacting lining (gaskets).
- b) The material stabilized with hydrocarbon may be packed in galvanized iron or mild steel with coating of non-reactive material or HM-HDPE drums with non-reacting gaskets on the stoppers. The drums shall be free from contaminations like oil and grease, rust, etc, and shall be tested previously at a pressure of 1 bar. The material stabilized with ethyl alcohol may be packed in tin cans, tinned mild steel drums or stainless-steel drums which shall be dry and free from contaminants like oil and grease, rust, etc. The filling holes shall be hermetically sealed with suitable non-reacting gaskets. The latter two shall be previously tested at a pressure of 0.5 bar.
- c) The material may be also transported in mild steel or stainless-steel road tanker which shall be free from contaminations like oil and grease, rust, etc. Main holes and loading and unloading points shall be hermetically sealed with suitable non-reacting gaskets like PTFE and NAF, etc.

6.2 Storing

The material of both pure and technical grade shall be stored in original container, protected from direct sunlight. Keep container tightly closed and sealed until ready for use. Containers that have been

opened must be carefully resealed and kept upright to prevent leakage.

6.3 Marking

6.3.1 Each container shall be securely closed and bear the following information:

- a) Name of the material;
- b) Name of the manufacturer;
- c) Month and year of manufacture;
- d) Lot or batch number;
- e) Net weight and gross weight; and
- f) Any other statutory requirement.

6.3.2 Each container shall also bear the following cautionary markings in clear bold letters:

CHLOROFORM

STORE IN COOL AND DRY PLACE.

PROTECT FROM DIRECT SUNLIGHT.

**USE WITH ADEQUATE VENTILATION,
WEAR MASK AND NECESSARY**

**PERSONAL PROTECTIVE EQUIPMENTS
DURING HANDLING**

6.3.3 The pure grade used for analytical purposes may also be labelled with the complete analytical data for the characteristics given in [Table 1](#).

6.3.4 BIS Certification Marking

The product(s) conforming to the requirements of this standard may be certified as per the conformity assessment schemes under the provisions of the *Bureau of Indian Standards Act, 2016* and the Rules and Regulations framed thereunder, and the products may be marked with the Standard Mark.

7 SAMPLING

The method of drawing representative samples shall be as prescribed in [Annex N](#).

ANNEX A

[\[Clause 2\]](#)

LIST OF REFERRED STANDARDS

<i>IS No.</i>	<i>Title</i>	<i>IS No.</i>	<i>Title</i>
IS 265 : 2021	Hydrochloric acid — Specification (<i>fifth revision</i>)	IS 2362 : 1993	Determination of water by the Karl Fischer method — Test method (<i>second revision</i>)
IS 878 : 2008/ ISO 4788 : 2005	Laboratory glassware — Graduated measuring cylinders (<i>second revision</i>)	IS 2618 : 2016/ ISO 4142 : 2002	Laboratory glassware — Test tubes (<i>third revision</i>)
IS 915 : 2012/ ISO 1042 : 1998	Laboratory glassware — One-mark volumetric flasks (<i>third revision</i>)	IS 2837 (Part 2) : 1977	Specification for porcelain crucibles and basins: Part 2 Basins (<i>first revision</i>)
IS 1070 : 2023	Reagent grade water — Specification (<i>fourth revision</i>)	IS 4161 : 2023	Nessler cylinders — Specification (<i>first revision</i>)
IS 1575 : 2003/ ISO 4800 : 1998	Laboratory glassware — Separating funnels and dropping funnels (<i>second revision</i>)	IS 4905 : 2015/ ISO 24153 : 2009	Random sampling and randomization procedures (<i>first revision</i>)

ANNEX B

[Clause [D-3](#) and [Table 1, Sl No. \(i\)](#)]

DETERMINATION OF RELATIVE DENSITY

B-1 OUTLINE OF THE METHOD

In this method, mass of equal volumes of the material and water at the same temperature are compared using relative density bottle.

B-2 APPARATUS

B-2.1 Relative Density Bottle — 25 ml capacity

B-2.2 Water Bath — maintained at $27.0\text{ }^{\circ}\text{C} \pm 0.2\text{ }^{\circ}\text{C}$

B-2.3 Thermometer — any convenient thermometer of a suitable range with 0.1° or 0.2° sub-divisions

B-3 PROCEDURE

B-3.1 Clean and dry the relative density bottle, weigh and then fill with recently boiled and cooled water at $27\text{ }^{\circ}\text{C}$. Fill to overflowing by holding the relative density bottle on its side in such a manner as to prevent entrapment of air bubbles. Insert the

stopper and immerse in the water-bath. Keep the entire bulb of the bottle completely covered with water and hold at that temperature for 30 min. Carefully, remove any water which has exuded from the capillary opening. Remove from the bath, wipe completely dry, cool and weigh. Calculate the mass of water. Again clean and dry the relative density bottle. Using the material under test, proceed exactly as in the case of water and weigh the bottle with the material.

B-3.2 Calculation

$$\text{Relative density at } 27\text{ }^{\circ}\text{C}/27\text{ }^{\circ}\text{C} = \frac{A - B}{C - B}$$

where

A = mass, in g, of relative density bottle filled with the material;

B = mass, in g, of the clean and dry relative density bottle; and

C = mass, in g, of the relative density bottle filled with water.

ANNEX C

[Table 1, Sl No. (ii)]

DETERMINATION OF DISTILLATION RANGE

C-1 APPARATUS

C-1.1 Distillation Flask — of the shape and dimensions shown in [Fig. 1](#)

C-1.2 Thermometer — of the mercury in glass partial, immersion type, having a range between 0 °C to 100 °C, graduated at each 0.2° and

having a maximum error of 0.4° .

C-1.3 Liebig Condenser — with a wall thickness of 1.0 mm to 1.5 mm and conforming to the shape and dimensions given in [Fig. 2](#)

C-1.4 Receiver — 100 ml capacity, with dimensions and graduations as shown in [Fig. 3](#)

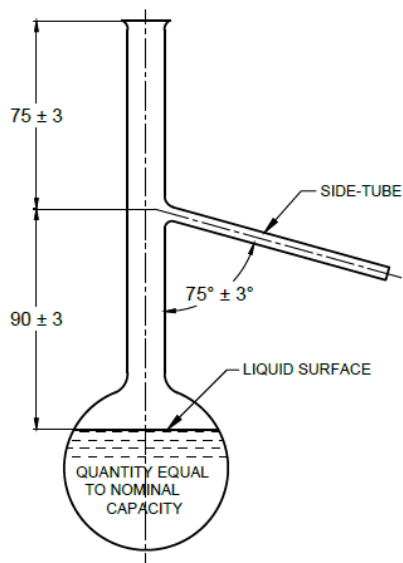

All dimensions in millimeters.

FIG. 1 DISTILLATION FLASKS

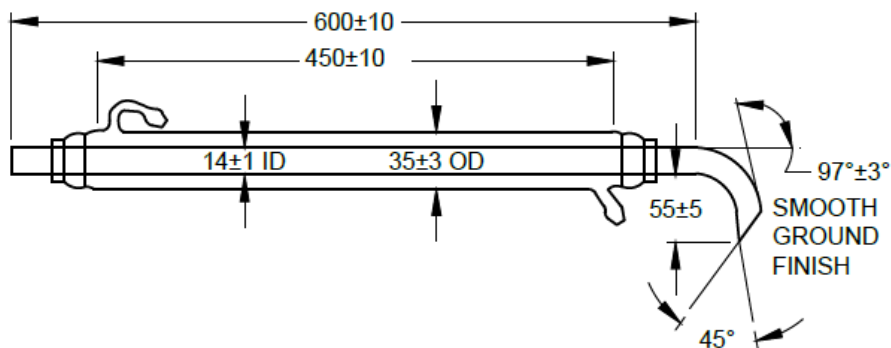

All dimensions in millimeters.

FIG. 2 LIEBIG CONDENSER

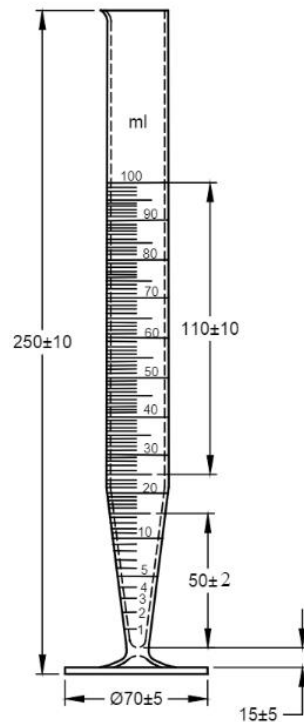

All dimensions in millimeters.

FIG. 3 RECEIVER

C-1.5 Rectangular Draught Screen

It is made of 0.8 mm thick metal sheet with the dimensions shown in Fig. 4 and open at the top and bottom. It shall comply with the following requirements:

- a) In each of the two narrower sides of the draught screen, there shall be two circular air vents 25 mm in diameter, situated below the asbestos shelf, as shown in Fig. 4. In each of the four sides of the draught screen there shall be three air vents with their center 25 mm above the base of the draught screen. These holes shall occupy the positions shown in Fig. 4, the diameter of each of the holes centrally situated in the wider sides being 25 mm, and of the remaining ten holes 12.5 mm. At the middle of each of the wider sides, there shall be a vertical slot for the side-tube of the distillation flask, with dimensions as shown in Fig. 4 and cut downwards from the top of the screen. A removable shutter conforming to the dimensions shown in Fig. 5 shall be provided for closing vertical slot not in use.
- b) A shelf of hard asbestos board, 6 mm in thickness, and having a central hole 110 mm in diameter, shall be supported horizontally, in the screen and shall fit closely to the sides of the screen to ensure that hot gases from the source of heat do not come in contact with the sides or neck of the flask. The supports for asbestos shelf may conveniently consist of triangular pieces of metal sheet firmly fixed to the screen at its four corners.
- c) In one of the narrower sides of the screen a door shall be provided having dimensions and position as shown in Fig. 4. In each of the narrower sides of the screen a mica window shall be placed centrally with the bottom of the window on a level with the top of the asbestos shelf. The dimensions and position of the windows are shown in Fig. 4.
- d) An asbestos board 150 mm × 150 mm × 6 mm in size having a central hole 50 mm in diameter shall be so placed on the asbestos shelf that the two holes are approximately concentric and the distillation flask when in position completely closes the hole of the asbestos board.

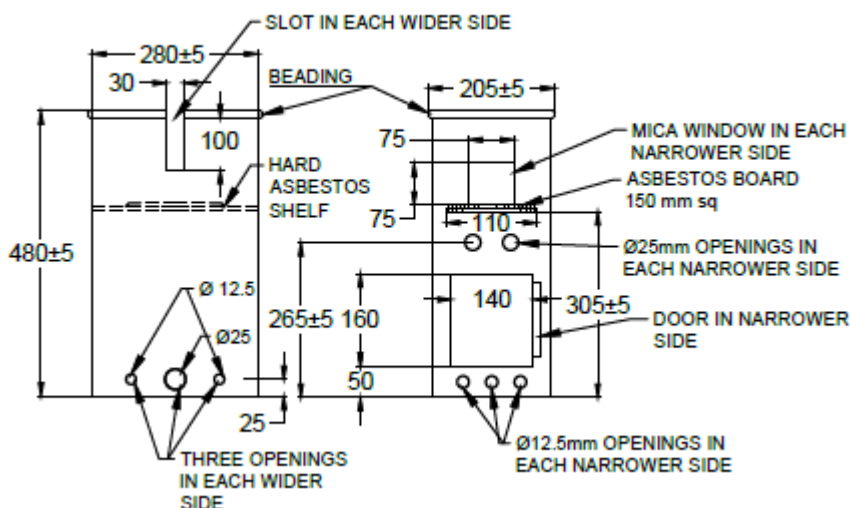

All dimensions in millimeters.

FIG. 4 RECTANGULAR DRAUGHT SCREEN

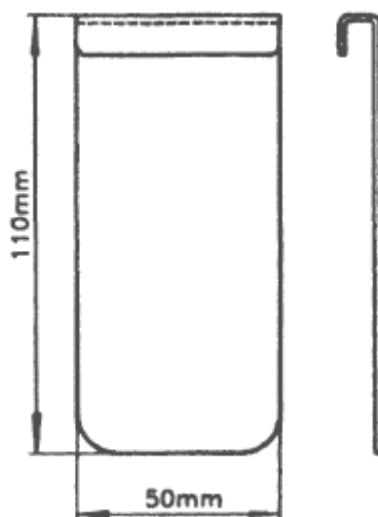

All dimensions in millimeters.

FIG. 5 REMOVABLE SHUTTER

C-1.6 Electric Heater, Gas Burner or Other Flame Type Heater

Any suitable heater or burner that enables the distillation to be carried out as described in [C-2](#).

C-1.7 Assembly of the Apparatus

C-1.7.1 Assemble the apparatus as shown in [Fig. 6](#).

C-1.7.1.1 Position of thermometer

The thermometer shall be held concentrically in the neck of the flask by means of a well-fitting

stopper of a material which is not capillary tube and the main bulb of the thermometer shall be maintained in level with the lower edge of the joint of the side-tube and the neck of the flask. The stopper shall project about 10 mm above the top of the neck of the flask. When the thermometer is fixed in position as indicated above, the immersion line on the thermometer shall be in the neighborhood of the top of the cork holding the thermometer.

C-1.7.1.2 Support for flask

The asbestos board [[see C-1.5 \(d\)](#)] shall be so

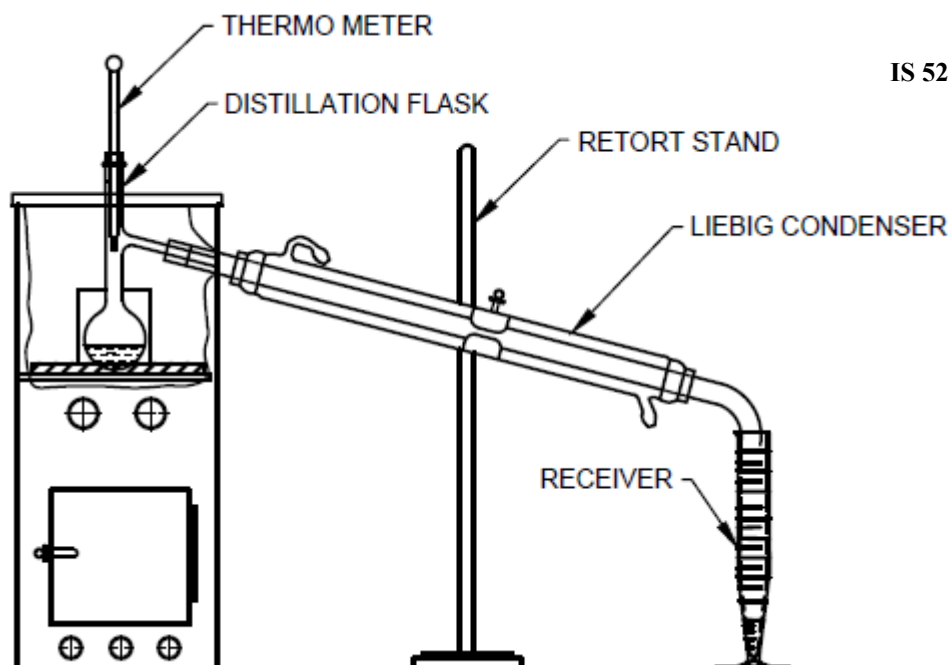

All dimensions in millimeters.

FIG. 6 ASSEMBLY OF APPARATUS

placed on the top of the asbestos shelf of the draught screen that the two holes are approximately concentric. The flask shall then be placed in position and pressed down so as to close completely the hole in the asbestos board.

C-1.7.1.3 Connection of flask to liebig condenser

The flask is so connected to the condenser that the end of the side-tube projects at least 25 mm into the condenser and is coaxial with it.

C-2 PROCEDURE

Measure 100 ml of the material in the receiver. Transfer the liquid as completely as possible to the distillation flask and add a few small pieces of clean, dry porous earthenware or stoneware. Place the flask, thermometers and receiver in position and ensure that the condenser has a steady supply of water. Apply heat at uniform rate so regulated that the first drop of distillate falls from the end of the condenser in 5 min to 10 min. Further regulate heat so that the distillate is collected at the rate of 3 ml to 4 ml per minute. Note the temperature in the thermometer when 2 ml and 97 ml of the distillate has collected in the receiver. Discard any liquid on the side of the flask.

C-3 CORRECTION OF THERMOMETER READING

C-3.1 Error of Scale

In all thermometer readings, make the corrections as indicated on the certificate of the instrument.

C-3.2 Correction for Barometric Pressure

If the barometric pressure prevailing during the determination is 760 mmHg, no correction need be applied to the observed temperature of the boiling range. If the barometric pressure deviates from 760 mmHg, the observed temperature shall be corrected as follows:

- a) For every 10 mm above 760 mmHg, subtract 0.40 °C from the observed temperature of boiling range to get the specified temperature range as per [Table 1](#); and
- b) For every 10 mm below 760 mmHg, add 0.40 °C to the observed temperature of boiling range to get the specified temperature range as per [Table 1](#).

NOTE — These corrections are valid only for pressure above 700 mmHg.

ANNEX D

[Table 1, Sl No. (iii)]

DETERMINATION OF RESIDUE ON EVAPORATION/ NON-VOLATILE MATTER CONTENT

D-1 APPARATUS

D-1.1 Porcelain Basin — 150 ml capacity
[see IS 2837 (Part 11)]

D-1.2 Water Bath

D-1.3 Oven — capable of maintaining temperature between 105 °C to 110 °C

D-2 PROCEDURE

Clean the basin and dry in a desiccator. Weigh the empty basin (previously conditioned in the oven at 105 °C to 110 °C for 30 min and cooled in a desiccator) to the nearest 0.000 2 g (M_1). Take 100 ml of the material in the basin. Evaporate the material over a water bath in a fume cupboard to

almost dryness. Further heat in the oven at 105 °C to 110 °C for 30 min. Cool in a desiccator and weigh accurately (M_2). Repeat the heating for 15 min, followed by cooling and weighing till, two consecutive weighing's do not differ by more than 0.5 mg.

D-3 CALCULATION

$$\text{Residue on evaporation percent by mass} = \frac{M}{v \times d}$$

where

$M = M_2 - M_1$, mass, in g, of the residue;

v = volume, in ml, of the material taken for the test; and

d = density of the material (see [Annex B](#)).

ANNEX E

[Table 1, Sl No. (iv)]

DETERMINATION OF FREE CHLORINE CONTENT

E-1 OUTLINE OF THE METHOD

The material is shaken with potassium iodide solution (see [E-3.1](#)) and the blue colour developed is noted.

E-2 APPARATUS

E-2.1 Graduated Measuring Cylinder — 25 ml, glass stoppered (see IS 878)

E-3 REAGENT

E-3.1 Potassium Iodide Solution

Dissolve 100 g potassium iodide in 1 000 ml of

distilled water. Store the solution in the dark.

E-4 PROCEDURE

E-4.1 Place 5 ml of sample in a ground glass stopper tube. Add 5 ml of potassium iodide solution and 0.2 g of soluble starch. Shake the tube for 30 s and keep in the dark for 5 min.

E-4.2 The material shall be considered as showing no free chlorine if no blue colour is developed within 5 min.

ANNEX F

[Table 1, Sl No. (v)]

DETERMINATION OF ACIDITY (as HYDROCHLORIC ACID)

F-1 REAGENTS**F-1.1 Bromothymol Blue Indicator**

Dissolve 0.5 g of water-soluble bromothymol blue crystals in 100 ml of water. Dilute 80 ml of this solution to 500 ml with methyl alcohol.

F-1.2 Standard Sodium Hydroxide Solution — 0.01 N**F-2 PROCEDURE**

To 100 ml of water, neutral to bromothymol blue, add 100 ml of the material and shake vigorously for 1 min at least. Add bromothymol blue indicator and

titrate with standard sodium hydroxide solution until a bluish green end point persists for 1 min.

F-3 CALCULATION

$$\begin{aligned} \text{Acidity (as HCl), percent by mass} \\ = \frac{3.65 \times V \times N \times 100}{v \times d} \end{aligned}$$

where

V = volume, in ml, of standard sodium hydroxide solution;

N = normality of standard hydroxide solution;

v = volume, in ml, of the material taken for the test; and

d = relative density of the material.

ANNEX G

[\[Table 1, Sl No. \(vi\) and \(vii\)\]](#)

DETERMINATION OF ALDEHYDES AND KETONES CONTENT

G-1 GENERAL

This test is applicable only to pure grade of the material.

G-2 APPARATUS

G-2.1 Separating Funnel — 25 ml capacity

G-3 REAGENTS

G-3.1 Mercuric Chloride — solid

G-3.2 Potassium Iodide — solid

G-3.3 Sodium Hydroxide Solution — 9 N

G-3.4 Nessler's Reagent

Dissolve 8 g of mercuric chloride in 50 ml of water and add a solution of 74 g potassium iodide in 50 ml

of water. Decant red precipitate of mercuric iodide and wash three times with water. Add 5 g of potassium iodide and just that quantity of water which would dissolve the precipitate completely. Make up the solution to 100 ml, with sodium hydroxide solution. Decant to free from any sediment and keep in well-stoppered bottle in a dark place.

G-4 PROCEDURE

G-4.1 Take 3 ml of the material in the separating funnel, add 10 ml of ammonia-free water, and shake for 5 min. Take 5 ml of the aqueous phase and add to it 40 ml of water and 5 ml of Nessler's reagent.

G-4.2 The limits for aldehydes/ketone specified in [Table 1](#) shall be taken not to have been exceeded if no turbidity or precipitate is produced within 1 min.

ANNEX H

[\[Table 1, Sl No. \(viii\)\]](#)

DETERMINATION OF PHOSGENE CONTENT

H-1 GENERAL

This test is applicable only to pure grade of the material.

H-2 APPARATUS

H-2.1 Test Tube — not more than 10 mm in outer diameter (*see* IS 2618).

H-2.2 Pipette

H-3 REAGENT

H-3.1 Barium Hydroxide Solution — saturated. Filter before use.

H-4 PROCEDURE

H-4.1 Take 10 ml of the material in the test tube. Add carefully by means of pipette without disturbing the surface of the liquid, sufficient quantity of saturated barium hydroxide solution to form a layer about 5 mm deep observe the junction of liquids in strong diffused light.

H-4.2 The material shall be taken to have passed the test for phosgene, if no white film is seen at the liquid junction.

ANNEX J

[Table 1, Sl No. (ix)]

DETERMINATION OF CHLORIDES

J-1 GENERAL

This test is applicable only to pure grade of the material.

J-2 APPARATUS

J-2.1 Separating Funnel — 100 ml capacity (see IS 1575).

J-3 REAGENT**J-3.1 Silver Nitrate Solution**

Dissolve 17 g of silver nitrate (AgNO_3) in water

and make up the volume to 1 000 ml. Store in a cool place away from light in blue bottles.

J-4 PROCEDURE

J-4.1 Take 17 ml of the material in a separating funnel and add 25 ml of water. Shake well for 5 min. Allow the liquids to separate and discard the chloroform layer. Take 10 ml of the aqueous phase in a test tube and add 5 drops of silver nitrate solution. Shake and watch for any turbidity.

J-4.2 The limit for chlorides prescribed in [Table 1](#) shall be taken not to have been exceeded if no turbidity is produced within 1 min.

ANNEX K

[Table 1, Sl No. (x)]

DETERMINATION OF MOISTURE

K-1 PROCEDURE

Take 100 ml of the hydrocarbon stabilized or 50 ml of alcohol stabilized material ([see 4.3](#)) and

determine the moisture content as prescribed in IS 2362.

NOTE — Karl Fischer auto titrator may also be used.

ANNEX L

[Table 1, Sl No. (xi) and (xiii)]

DETERMINATION OF METHYL CHLORIDE, METHYLENE CHLORIDE AND CARBON TETRACHLORIDE (IMPURITIES) AND CHLOROFORM CONTENT (PURITY)

L-1 OUTLINE OF THE METHOD

The chlorinated compounds like methyl chloride, methylene chloride and carbon tetrachloride as present in chloroform in small amounts and purity of chloroform is determined by gas chromatography.

L-2 APPARATUS

L-2.1 Gas Chromatograph

L-2.1.1 Any commercially available gas chromatograph dual column with a flame ionization detector, a split injector and a suitable electronic integrator/software can be used with following accessories and operating condition:

- i) Column : fused silica, stationary phase of percent cyanopropyl phenyl-(94 percent)-dimethyl polysiloxane with length 30 m; internal diameter 0.53 mm and film thickness 3.0 μm or equivalent.

- ii) Carrier gas (H_2) flow rate, ml/min : 10
 iii) Split ratio, ml/min : 10 : 1
 iv) Make up (N_2) flow ml/min : 25
 v) Hydrogen flow rate, ml/min : 30
 vi) Zero air flow rate, ml/min : 300
 vii) Septum purge flow rate, ml/min : 3
 viii) Sample size, μl : 2 (may be vary as per user method suitability)

L-2.1.2 Temperature Programme of Oven, Detector and Injector:

Injector Temperature, $^{\circ}\text{C}$	Detector Temperature, $^{\circ}\text{C}$	Oven		
		Temperature, $^{\circ}\text{C}$	Hold Time, min	Ramp Rate, $^{\circ}\text{C}/\text{min}$
250 $^{\circ}\text{C} \pm 1$ $^{\circ}\text{C}$	250 $^{\circ}\text{C} \pm 1$ $^{\circ}\text{C}$	40 \pm 1	5	10
		160	1	—

NOTE — The above gas chromatographic (GC) conditions are suggestive if used hydrogen as a carrier gas. However, any GC method having difference in detector, column packing material and type (like packed/capillary, diameter, length, film thickness etc), calibration technique (internal std, external std, area normalization, percent area etc), carrier gas (He , H_2 , N_2) may be used with applicable GC operating parameters, provided standardization and calibration of the components is established after setting GC parameters for the resolution and accuracy level as specified in this standard.

L-2.2 Microlitre Syringe — 10 µl or 25 µl capacity

L-3 REAGENTS

L-3.1 Synthetic Standard

methylene chloride, carbon tetrachloride and required stabilizer in pure chloroform as tabulated below:

For synthetic standard, mix methyl chloride,

<i>Sl No.</i>	<i>Component</i>	<i>Concentration, percent by mass</i>
(1)	(2)	(3)
i)	Methyl chloride	: 0.008 to 0.009
ii)	Methylene chloride	: 0.008 to 0.009
iii)	Carbon tetrachloride	: 0.000 4 to 0.001 0
iv)	Stabilizer:	
	a) for hydrocarbon stabilized material	: 0.003 5 ± 0.001 5
	or	
	b) for alcohol stabilized material	: 1.5 percent (m/v)
v)	Chloroform	: balance

L-4 TEST SUBSTANCES

The following components are estimated:

- Methyl chloride;
- Methylene chloride;
- Carbon tetrachloride; and
- Purity

L-5 PROCEDURE

L-5.1 Calibration

Internal normalization is the method used for calibration of the results of the analysis. Because of low contents of unknown impurities, it is not necessary to use correction factors for converting the percentage of the areas into percentage by mass, so that these factors in the calculation formula have the value $R_f = 1$. In case of examples with higher contents of impurities, there is a need for determining correction factors; this should be done by using a synthetic standard solution. The mixture is run through the chromatograph. This would give the positions at which each component would elute. By comparison of the actual values obtained for the standard and the composition of the standard prepared the correction factor

for the component may be calculated.

L-5.2 Sample Injection

Rinse the 10 µl or 25 µl syringe with acetone twice and dry for 2 min or longer. Rinse the syringe twice before filling it with 1 ml of the synthetic standard. Inject standard solution (as per sample size defined in [L-2.1.1](#)) into the gas chromatograph and obtain a standard chart. Rinse the syringe twice with the material under test and inject the same sample size used for standard solution into the gas chromatograph. It is imperative that the same injection technique is used and the syringe used in the operation is not used with any other type of solvent. It is very necessary to prevent contamination.

L-5.3 Interpretation of Chromatogram

Elution order of the components is methyl chloride, stabilizer, methylene chloride, chloroform and carbon tetrachloride. Identification is done with the aid of a test mixture.

NOTE — Elution order of the components may vary depending on capillary column used for analysis. Identification is done by injecting individual standard of impurity.

L-5.4 Response factor (R_f)

L-5.4.1 Inject synthetic standard mixture (see [L-3.1](#)) three times one by one and read the response/area percentage of methyl chloride, methylene chloride, carbon tetrachloride and stabilizer. Calculate the response factor for impurities in standard by using given formula.

Response factor (R_f) of methyl chloride, methylene chloride, carbon tetrachloride and stabilizer:

$$R_f = \frac{\text{Actual Concentration (percent) of Interested Impurity}}{\text{Area percent from GC}}$$

L-5.4.2 Calculate the average response factor for all individual impurity as average of three readings. The final response factor of individual Impurity shall be taken for the calculation of impurities concentration in chloroform.

L-6 CALCULATION

- For Impurities:
Interested impurity, percent = Interested impurity (area percent) × response factor of interested impurity
- For purity, percent: 100 – (sum of all impurities including stabilizer)

ANNEX M

[Table 1, Sl No. (xii)]

DETERMINATION OF COLOUR

M-1 OUTLINE OF THE METHOD

The colour of the material is compared with that of the colour standard and expressed in terms of Pt-Co. The Pt-Co is defined as the colour of an aqueous solution, containing 1 part per million of platinum in the form of the chloroplatinic acid and 2 part per million of cobaltous chloride.

M-2 APPARATUS

M-2.1 Nessler Cylinders — two, 100 ml capacity (see IS 4161)

M-2.2 One Mark Volumetric Flasks — 250 ml and 500 ml capacity (see IS 915)

M-3 REAGENTS

M-3.1 Cobaltous Chloride Hexahydrate — solid

M-3.2 Hydrochloric Acid (see IS 265)

M-3.3 Chloroplatinic Acid

Dissolve 250 mg of platinum in small quantity of aqua regia contained in a glass of porcelain basin by heating on a water bath. When the metal dissolved, evaporate the solution to dryness. Add 1 ml of hydrochloric acid and again evaporate to dryness. Repeat this operation twice.

M-4 PREPARATION OF COLOUR STANDARD

M-4.1 Dissolve 0.50 g of the cobaltous chloride hexahydrate and whole of the chloroplatinic acid in 50 ml of the hydrochloric acid. Warm, if necessary, to obtain a clear solution and after cooling, pour into the 500 ml one-mark graduated flask. Dilute with water to the mark.

M-4.2 Pipette 7.5 ml of the solution (see [M-4.1](#)) into a 250 ml one-mark graduated flask and dilute with water to the mark. The diluted solution corresponds to a colour of 15 Hazen units and should always be freshly prepared.

M-5 PROCEDURE

M-5.1 Fill one of the Nessler cylinders to the mark with the material to be tested, and the other with the colour standard. Compare the colour using a white background.

M-5.2 The material shall be taken to have passed the test if the colour of the sample is not darker than that of the colour standard.

NOTE — Automated colour measurement instruments such as spectrophotometers, colorimeters and colour comparators may also be used for determination of colour. It shall be ensured that suitable instrument used for colour determination must be calibrated with certified reference material before use or as per instrument manual instructions.

ANNEX N

(Clause 7)

SAMPLING OF CHLOROFORM, PURE AND TECHNICAL

N-1 GENERAL REQUIREMENT OF SAMPLING

N-1.1 The sampling instrument shall be clean and dry.

N-1.2 Precautions shall be taken to protect the sample, the material being sampled, the sampling instrument and the containers for samples from adventitious contamination.

N-1.3 To draw a representative sample, the contents of each container selected for sampling shall be mixed thoroughly by shaking or stirring or both by suitable means, or by rolling.

N-1.4 The samples shall be placed in suitable, clean dry, and airtight, metal, or dark or amber glass containers on which the material has no action.

N-1.5 The sample containers shall be of such a size that they are almost completely filled by the sample.

N-1.6 Each sample container shall be sealed airtight after filling and marked with full details of sampling, the date sampling, and the month and year of manufacture of the material.

N-1.7 Samples shall be stored in the dark.

N-2 SAMPLING INSTRUMENT

N-2.1 The following sampling instrument may be used:

- a) Sampling bottle or can, for taking samples from tanks or drums; and

- b) Sampling tube, for taking samples from bottles or small containers.

N-2.1.1 Sampling Tube

Made of metal or thick glass, 30 mm \pm 10 mm in diameter and 700 mm \pm 100 mm in length (see Fig. 7). The upper and lower ends are conical and reach 5 mm to 10 mm diameter at the narrow ends. Handling is facilitated by two rings at the upper end.

N-2.1.2 Sampler with Ground Closure

Made of steel and having a capacity of 500 ml to 1 000 ml (see Fig. 8).

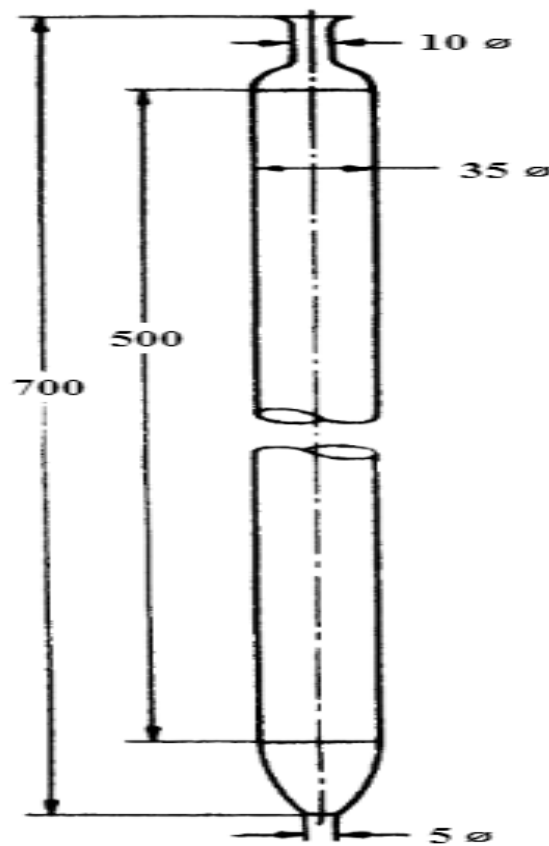

All dimensions in millimeter.

FIG. 7 PIPETTE

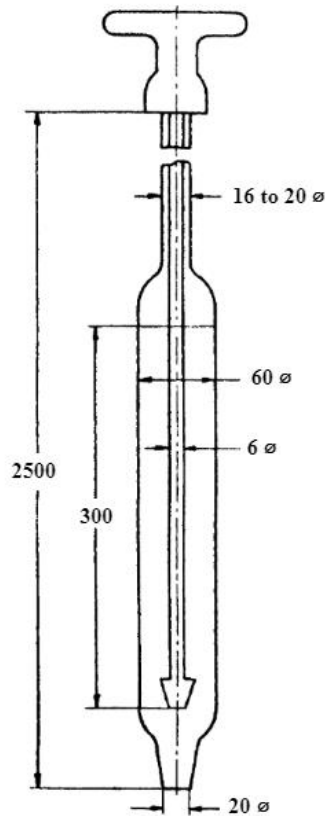

All dimensions in millimeter.

FIG. 8 STEEL SAMPLER WITH GROUND CLOSURE

N-2.1.3 Sampling Bottle or Can

Consists of a weighed glass or metal containers with removable stopper or top to which is attached a light chain (see [Fig. 9](#)). The bottle or the can is fastened

to a suitable pole. For taking a sample, the bottle or the can is lowered into the tank to the required depth and the stopper is then removed by means of the chain.

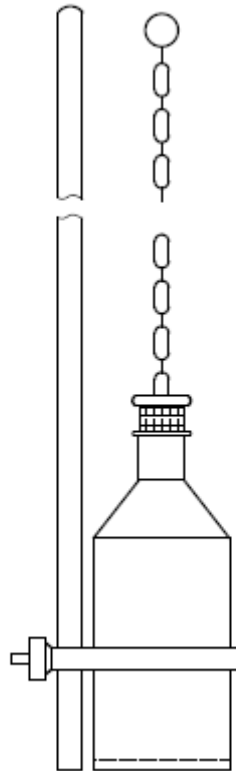
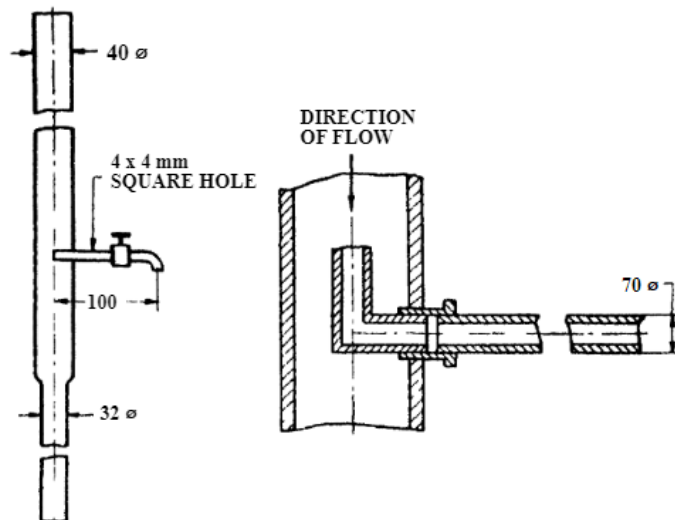

FIG. 9 SAMPLING BOTTLE OR CAN

N-2.1.4 Continuous Sampler

It shall be made of steel (*see* [Fig. 10](#)).



All dimensions in millimeter.

FIG. 10 CONTINUOUS SAMPLER

N-3 SCALE OF SAMPLING

N-3.1 For Tanks and Drums

Each tank, road tankers or drum shall be sampled separately

N-3.2 For Bottles and Small Containers

Each lot (*see* [N-3.2.2](#)) shall be sampled separately.

N-3.2.1 Lot

In any consignment, all the containers of the same grade and drawn from a single batch of manufacture shall constitute a lot. If a consignment is known to consist of different batches of manufacture or of different grades, the containers belonging to the same batch and grade shall be grouped together and each such group shall constitute a separate lot.

N-3.2.2 The number of containers (n) to be selected from a lot shall depend on the size of the lot (N) and shall be in accordance with [Table 2](#).

N-3.2.3 These containers shall be selected from the lot at random. In order to ensure randomness of selection, a random number table may be used. For guidance and use of random number table, IS 4905 may be referred. In the absence of random number table, the following procedure may be adopted:

Starting from any container in the lot, count the containers as 1,2,3, etc up to r and so on, in one order. Every r^{th} container thus counted shall be withdrawn to constitute the sample where r is the integral part of N/n (N and n being the lot size and sample size respectively).

Table 2 Scale of Sampling
([Clause N-3.2.2](#))

Sl No.	Lot Size	No. of Containers to be Selected
(1)	N (2)	n (3)
i)	Up to 4	All
ii)	5 to 10	5
iii)	11 to 20	6
iv)	21 to 30	7
v)	31 to 50	8
vi)	51 to 75	9
vii)	76 to 100	10
viii)	101 to 125	11
ix)	126 to 150	12
x)	151 to 200	13
xi)	201 and above	14

N-4 TEST SAMPLE AND REFEREE SAMPLE**N-4.1 From Tanks and Drums**

As far as possible, samples from a tank or drum should be drawn during the operation of filling. In that case, equal amounts of the material shall be collected at regular intervals so as to get a total amount of about 1 800 ml. Where it is not possible to take a sample during filling, the material shall be drawn from different position and depths with the sampling bottle or can after thoroughly agitating the material so as to ensure a fair amount of homogeneity. The total amount of the material collected shall be thoroughly mixed and divided into three equal portions, one for the purchaser, another for the supplier and the third for the referee.

N-4.2 From Bottles and Small Containers

From each of the bottles or containers selected according to [N-3.2.3](#), a small representative portion of the material shall be drawn with the help of the sampling tube. Equal quantities of the material so drawn from the various containers shall be thoroughly mixed to form a test sample of about 1 800 ml. This shall be divided into three equal parts, one for the purchaser, another for the supplier and the third for the referee.

N-4.3 All the test samples shall be transferred to separate sample containers and sealed and labelled with full identification particulars. The referee test sample bearing the seal of both the purchaser and the supplier shall be kept at a place agreed to between the two and shall be used in case of a dispute.

N-5 TESTS

Tests for the determination of all the requirements given in this specification shall be performed on-the composite sample obtained in [N-4.1](#) or [N-4.2](#).

N-6 CRITERIA FOR CONFORMITY

The lot shall be declared as conforming to this specification if all the test results satisfy the prescribed requirements.

ANNEX P

(Foreword)

COMMITTEE COMPOSITION

Organic Chemicals, Alcohols and Allied Products Sectional Committee, PCD 09

<i>Organization</i>	<i>Representative(s)</i>
National Chemical Laboratory (NCL), Pune	DR C. V. RODE (<i>Chairperson</i>)
Alkyl Amines Chemicals Limited, Mumbai	SHRI S. V. NIKUMBHE SHRI SAMEER KATDARE (<i>Alternate</i>)
All India Alcohol-Based Industries Development Association (AABIDA), Mumbai	SHRI K. L. RAPHAEL SHRI KIRTI GAJJAR (<i>Alternate</i>)
All India Distillers Association (AIDA), New Delhi	SHRI V. N. RAINA
BASF India Limited, Mumbai	SHRI KIRAN BHAT SHRI HEMAL (<i>Alternate</i>)
Chemical and Petrochemicals Manufacturers Association (CPMA), New Delhi	SHRI UDAY CHAND
CSIR - Central Drug Research Institute (CDRI), Lucknow	DR SANJEEV KANOJIYA
Deepak Fertilizer, New Delhi	DR L. B. YADAWA SHRI SURESH AMLE (<i>Alternate</i>)
Deepak Phenolics Limited, Vadodara	SHRI DHARMESH SIDDHAPURIA SHRI SANDIP KUMAR PANDYA (<i>Alternate</i>)
Department of Chemicals and Petrochemicals, Ministry of Chemicals and Fertilizers, New Delhi	SHRI O. P. SHARMA SHRI VARUN SINGH POONIA (<i>Alternate</i>)
Dow Chemical International Private Limited, Mumbai	SHRI V. MOHANDOSS SHRI GOVIND GUPTA (<i>Alternate</i>)
Godavari Biorefineries, Mumbai	SHRI SHANUL LAXMANRAO PAGAR SHRI APPASAHEB J. WANI (<i>Alternate</i>)
Gujarat Narmada Valley Fertilizers Company Limited, Ahmedabad	DR R. M. PATEL SHRI C. S. PATEL (<i>Alternate</i>)
Hindustan Organic Chemicals Limited (HOCL), Mumbai	SHRI DELEEP KUMAR K. DR B. RAJEEV (<i>Alternate</i>)
India Glycols Limited, 	DR R. K. SHARMA SHRI ALOK SINGHAL (<i>Alternate</i>)
Indian Chemical Council (ICC), Mumbai	DR MRITUNJAY CHAUBEY SHRI J. SEVAK (<i>Alternate</i>)

<i>Organization</i>	<i>Representative(s)</i>
Indian Oil Corporation Limited, Panipat	DR Y. S. JHALA
Jubilant Agri and Consumer Products Limited, Gurugram	DR KANAK BARAN DASS
Jubilant Life Sciences Limited, Noida	SHRI MANSUKH D. KANZARIYA
Laxmi Organic Industries, Mumbai	SHRI KRISHNA A. RAO SHRI KAMLESH FULCHAND SHINDE (Alternate)
National Chemical Laboratory (NCL), Pune	DR RAVINDAR KONTHAM DR UDAYA KIRAN MARELLI (Alternate)
Reliance India Limited (RIL), Mumbai	SHRI SREERAMACHANDRAN KARTHA SHRI VASANT WARKE (Alternate)
United Phosphorus Limited (UPL), Mumbai	SHRI M. D. VACHHANI
In Personal Capacity (37 Nandanvan Society, Near GNFC Township, Narmadanagar, Bharuch)	DR MAYUR J. KAPADIA
BIS Directorate General	SHRIMATI MEENAL PASSI, SCIENTIST 'F'/ SENIOR DIRECTOR AND HEAD (PETROLEUM, COAL AND RELATED PRODUCTS) [REPRESENTING DIRECTOR GENERAL (Ex-officio)]

Member Secretary
MS ADITI CHOUDHARY
SCIENTIST 'B'/ASSISTANT DIRECTOR
(PETROLEUM, COAL AND RELATED PRODUCTS), BIS

Bureau of Indian Standards

BIS is a statutory institution established under the *Bureau of Indian Standards Act, 2016* to promote harmonious development of the activities of standardization, marking and quality certification of goods and attending to connected matters in the country.

Copyright

BIS has the copyright of all its publications. No part of these publications may be reproduced in any form without the prior permission in writing of BIS. This does not preclude the free use, in the course of implementing the standard, of necessary details, such as symbols and sizes, type or grade designations. Enquiries relating to copyright be addressed to the Head (Publication & Sales), BIS.

Review of Indian Standards

Amendments are issued to standards as the need arises on the basis of comments. Standards are also reviewed periodically; a standard along with amendments is reaffirmed when such review indicates that no changes are needed; if the review indicates that changes are needed, it is taken up for revision. Users of Indian Standards should ascertain that they are in possession of the latest amendments or edition by referring to the website-www.bis.gov.in or www.standardsbis.in.

This Indian Standard has been developed from Doc No.: PCD 09 (22260).

Amendments Issued Since Publication

Amend No.	Date of Issue	Text Affected

BUREAU OF INDIAN STANDARDS

Headquarters:

Manak Bhavan, 9 Bahadur Shah Zafar Marg, New Delhi 110002

Telephones: 2323 0131, 2323 3375, 2323 9402

Website: www.bis.gov.in

Regional Offices:

	Telephones
Central : 601/A, Konnectus Tower -1, 6 th Floor, DMRC Building, Bhavbhuti Marg, New Delhi 110002	{ 2323 7617
Eastern : 8 th Floor, Plot No 7/7 & 7/8, CP Block, Sector V, Salt Lake, Kolkata, West Bengal 700091	{ 2367 0012 2320 9474
Northern : Plot No. 4-A, Sector 27-B, Madhya Marg, Chandigarh 160019	{ 265 9930
Southern : C.I.T. Campus, IV Cross Road, Taramani, Chennai 600113	{ 2254 1442 2254 1216
Western : Plot No. E-9, Road No.-8, MIDC, Andheri (East), Mumbai 400093	{ 2821 8093

Branches : AHMEDABAD. BENGALURU. BHOPAL. BHUBANESHWAR. CHANDIGARH. CHENNAI. COIMBATORE. DEHRADUN. DELHI. FARIDABAD. GHAZIABAD. GUWAHATI. HIMACHAL PRADESH. HUBLI. HYDERABAD. JAIPUR. JAMMU & KASHMIR. JAMSHEDPUR. KOCHI. KOLKATA. LUCKNOW. MADURAI. MUMBAI. NAGPUR. NOIDA. PANIPAT. PATNA. PUNE. RAIPUR. RAJKOT. SURAT. VISAKHAPATNAM.