

भारतीय मानक
Indian Standard

IS 18726 (Part 1) : 2024
ISO 14880-1 : 2019

प्रकाशिकी और फोटोनिक्स — सूक्ष्म लेंस
सरणियाँ

भाग 1 शब्दावली

Optics and Photonics — Microlens
Arrays

Part 1 Vocabulary

ICS 31.260; 01.040.31

© BIS 2024

© ISO 2019



भारतीय मानक ब्यूरो

BUREAU OF INDIAN STANDARDS

मानक भवन, 9 बहादुर शाह ज़फर मार्ग, नई दिल्ली - 110002

MANAK BHAVAN, 9 BAHADUR SHAH ZAFAR MARG

NEW DELHI - 110002

www.bis.gov.in www.standardsbis.in

August 2024

Price Group 10

NATIONAL FOREWORD

This Indian Standard (Part 1) which is identical to ISO 14880-1 : 2019 'Optics and photonics — Microlens arrays — Part 1: Vocabulary' issued by the International Organization for Standardization (ISO) was adopted by the Bureau of Indian Standards on the recommendation of the Optics and Photonics Sectional Committee and approval of the Production and General Engineering Division Council.

This standard aims to improve the compatibility and interchangeability of lens arrays from different suppliers and to enhance the development of technology of microlens arrays.

This standard has been published in five parts. The other parts in this series are:

- Part 2 Test methods for wave front aberrations
- Part 3 Test methods for optical properties other than wave front aberrations
- Part 4 Test methods for geometrical properties
- Part 5 Guidance on testing

The text of ISO standard has been approved as suitable for publication as an Indian Standard without deviations. Certain conventions are however not identical to those used in Indian Standards. Attention is particularly drawn to the following

- a) Wherever the words 'International Standard' appear referring to this standard, they should be read as 'Indian Standard'; and
- b) Comma (,) has been used as a decimal marker while in Indian Standards, the current-practice is to use a point (.) as the decimal marker.

Contents

Page

Introduction	iv
1 Scope	1
2 Normative references	1
3 Terms and definitions	1
3.1 Symbols and units of measure.....	2
3.2 Basic definitions of microlens and microlens array.....	2
3.3 General terms and definitions.....	3
3.4 Terms relating to properties of the microlens array.....	6
3.4.1 Geometrical properties.....	6
3.4.2 Optical properties.....	7
4 Coordinate system	8
5 Properties of individual lenses	9
Annex A (informative) Microlens array applications (1) — Telecommunications	11
Annex B (informative) Microlens array applications (2) — Image sensor arrays	12
Annex C (informative) Microlens array applications (3) — LCD projection panels	13
Annex D (informative) Microlens array applications (4) — Wavefront sensors	14
Annex E (informative) Microlens array applications (5) — Stereo displays	17
Annex F (informative) Microlens array applications (6) — 3D imaging and light-field cameras	18
Bibliography	20

Introduction

The expanded market in microlens arrays has generated a need to agree on basic terms and definitions for microlens arrays and systems and this document aims to satisfy that need.

This document aims to improve the compatibility and interchangeability of lens arrays from different suppliers and to enhance the development of technology using microlens arrays.

Microoptics and microlens arrays are found in many modern optical devices^[1]. They are used as coupling optics for detector arrays, the digital camera being an example of a mass market application. They are used to enhance the optical performance of liquid crystal displays, to couple arrays of light sources and to direct illumination for example in 2D and 3D television, mobile phone and portable computer displays. Microlens arrays are used in wavefront sensors for optical metrology and astronomy, lightfield sensors for three-dimensional photography and microscopy and in optical parallel processor elements.

Multiple arrays of microlenses can be assembled to form optical systems such as optical condensers, controlled diffusers and superlenses^{[2][3]}. Furthermore, arrays of microoptical elements such as micro-prisms and micro-mirrors are used^{[4][5]}. Examples of some of these applications are described in [Annexes A to F](#).

Indian Standard

OPTICS AND PHOTONICS — MICROLENS ARRAYS

PART 1 VOCABULARY

1 Scope

This document defines terms for microlens arrays. It applies to arrays of very small lenses formed inside or on one or more surfaces of a common substrate. This document also applies to systems of microlens arrays.

2 Normative references

There are no normative references in this document.

3 Terms and definitions

For the purposes of this document, the following terms and definitions apply.

ISO and IEC maintain terminological databases for use in standardization at the following addresses:

- ISO Online browsing platform: available at <https://www.iso.org/obp>
- IEC Electropedia: available at <http://www.electropedia.org/>

NOTE 1 The coordinate system used for the description of the microlenses can be found in [Figure 1](#). The description of the coordinate system and its application can be found in [Clause 4](#).

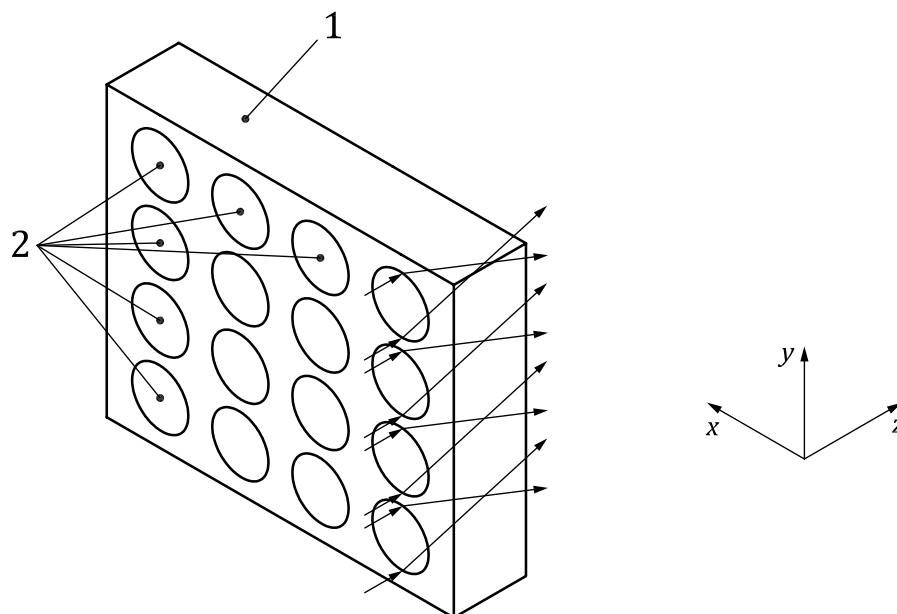

Key

- 1 substrate
- 2 microlenses

Figure 1 — Microlens array with Cartesian coordinate system

NOTE 2 Five common types of microlenses are illustrated in [Figure 5](#), and described in [Clause 5](#).

NOTE 3 For common microlens array applications, see [Annexes A](#) to [F](#).

3.1 Symbols and units of measure

[Table 1](#) lists symbols and units which are used in this document.

Table 1 — Symbols and units of measure

Symbol	Unit	Term
A_d	mm ²	diffraction-limited optical aperture
A_g	mm ²	geometric aperture
a_1, a_2	mm	lens radius
$2a_1, 2a_2$	mm	lens width
D_n	mm ⁻²	lens density
h	mm	surface modulation depth
L_1, L_2	mm	edge lengths of substrate
NA	none	numerical aperture
NA_d	none	diffraction-limited numerical aperture
NA_g	none	geometric numerical aperture
$n(x, y, z)$	none	refractive index
n_0	none	refractive index at the centre of the lens
P_x, P_y	mm	pitch
$f_{E,b}$	mm	effective back focal length
$f_{E,f}$	mm	effective front focal length
R_c	mm	radius of curvature
S_x, S_y, S_z	mm	coordinates of focal spot position
$\Delta S_x, \Delta S_y, \Delta S_z$	mm	focal spot position shift
T	mm	thickness of substrate
T_c	mm	physical thickness
w_x, w_y	µm	focal spot size
x, y, z	mm	coordinates of lens aperture centre position
θ	degree	acceptance angle
Φ_{rms}	parts of wavelength	wavefront aberration
λ	nm	wavelength
v_{eff}	none	effective Abbe-number

3.2 Basic definitions of microlens and microlens array

3.2.1

microlens

lens in an array with an aperture of less than a few millimetres including lenses which work by refraction at the surface, refraction in the bulk of the substrate, diffraction or a combination of these

Note 1 to entry: The microlens can have a variety of aperture shapes: circular, hexagonal or rectangular for example. The surface of the lens can be flat, convex or concave.

3.2.2

microlens array

regular arrangement of microlenses on/in a single substrate

Note 1 to entry: Irregular or structured arrays are sometimes used, for example, in beam shaping, diffusion, and homogenization.

3.3 General terms and definitions

3.3.1

effective front focal length

$f_{E,f}$

distance from the vertex of the microlens to the position of the focus given by finding the maximum of the power density distribution when collimated radiation is incident from the back of the substrate

Note 1 to entry: The effective front focal length can differ from the paraxial front focal length in the case of aberrated lenses.

Note 2 to entry: The effective front focal length is different from the classical effective focal length since it is measured from the lens vertex.

3.3.2

effective back focal length

$f_{E,b}$

distance from the back surface of the substrate or the vertex of the microlens to the position of the focal point, when collimated radiation is incident from the lens side of the substrate

Note 1 to entry: The effective back focal length can differ from the paraxial back focal length in the case of aberrated lenses.

Note 2 to entry: In case the microlens or microlenses are formed on both sides of the substrate, "effective back focal length" is defined from the vertex of the microlens to the position of the focal point.

3.3.3

radius of curvature

R_c

distance from the vertex of the microlens to the centre of curvature of the lens surface

Note 1 to entry: The radius of curvature is expressed in millimetres.

3.3.4

wavefront aberration

Φ_{rms}

root mean square of deviation of the wavefront from an ideal spherical or other wavefront

Note 1 to entry: The wavefront aberration is expressed in parts of the wavelength, λ .

3.3.5.1

chromatic aberration

change of the focal length with wavelength

Note 1 to entry: Chromatic aberration is characterized by the effective Abbe-number, which is given by:

$$v_{\text{eff}} = \frac{1}{\frac{1}{f(\lambda_1)} - \frac{1}{f(\lambda_3)}}$$

where the values of λ_1 , λ_2 and λ_3 are specified in order to correspond to current practice in optical lens design. The effective Abbe-number is dimensionless.

Note 2 to entry: At optical wavelengths the C line (656,3 nm) as λ_3 , d line (587,56 nm) as λ_2 , F line (486,1 nm) as λ_1 are generally used. However, other wavelengths such as the infrared spectrum can be used where appropriate, provided that $\lambda_1 < \lambda_2 < \lambda_3$.

3.3.5.2

achromatic microlens array

microlens array designed to limit the effects of chromatic aberration

Note 1 to entry: Achromatic microlens arrays are generally corrected to bring radiation of two wavelengths into focus in the same plane, for example, red and blue light or infrared wavelengths where appropriate.

3.3.6.1

aperture shape

shape which is specified as square, circular, hexagonal, circular sector or other geometric shape

Note 1 to entry: For non-regular shapes, the vertices of the microlens aperture are to be defined by coordinates, X_{jk}, Y_{jk} , where j is the microlens number index and k is the vertex number index.

3.3.6.2

geometric aperture

A_g
area in which the optical radiation passing through it is deviated towards the focused image and contributes to it

Note 1 to entry: For graded index microlenses where no obvious boundary exists, the edge is the locus of points at which the change of index is 10 % of the maximum value.

Note 2 to entry: The geometric aperture is expressed in square millimetres.

3.3.6.3

lens width

$2a_1, 2a_2$

width of the microlens on the substrate defined by the geometric aperture of the microlens

Note 1 to entry: The widths are determined by measuring the longest distance ($2a_1$) and the shortest distance ($2a_2$) between the lens edges as shown in [Figure 2](#). If the lens is circular symmetric, then the term diameter can be used.

Note 2 to entry: Lens widths are expressed in millimetres.

Note 3 to entry: The geometric aperture of the microlens can be given by a variety of shapes such as circular, rectangular, elliptical and so on.

3.3.6.4

diffraction-limited optical aperture

A_d
area within which the peak-to-valley wavefront aberrations are less than one quarter of the wavelength of the radiation with which it is tested

Note 1 to entry: The diffraction-limited optical aperture is expressed in square millimetres.

3.3.6.5

geometrical numerical aperture

NA_g

sine of half the angle subtended by the aperture of the lens at the focal point

3.3.6.6

diffraction-limited numerical aperture

NA_d

sine of half the angle subtended by the diffraction limited optical aperture of the lens at the focal point

3.3.7

focal ratio

ratio of the focal length to the lens width of the geometrical aperture

Note 1 to entry: The focal ratio is equivalent to the practical f -number.

3.3.8

imaging quality

quality of the microlens which is determined by Modulation Transfer Function (MTF) according to ISO 15529 or the Strehl ratio

Note 1 to entry: The imaging quality should be measured in the conjugates in which the microlenses are to be used and preferably for a range of angles of incidence.

3.3.9

focal spot size

w_x, w_y

half width in the x direction and y direction, respectively, at which power density is decreased to the $1/e^2$ irradiance levels at the practical focus point when the microlens is irradiated with a uniform plane wavefront

Note 1 to entry: Focal spot sizes are expressed in micrometres.

3.3.10

lenticular microlens array

array of cylindrical microlenses

Note 1 to entry: Historically the term lenticular means lens-shaped, but in practice it is used to describe cylindrical lenses.

3.3.11

beam homogenizer

one or more microlens arrays designed to shape the intensity distribution of an incident wavefront

3.3.12

structured microlens array

microlens array with regular or random geometry designed to shape an incident wavefront, often used for applications with a broad range of wavelengths

3.3.13

condenser array

dual array of cylindrical or spherical microlenses designed to illuminate a large field at a relatively short working distance

Note 1 to entry: For convenience, the dual arrays can be formed either side of a single substrate.

3.3.14

Gabor superlens

optical system formed from a pair of afocal microlens arrays which can have different periods and focal lengths

Note 1 to entry: The Gabor superlens is able to produce "integral" images which are very different from those produced by conventional lenses.

3.4 Terms relating to properties of the microlens array

3.4.1 Geometrical properties

3.4.1.1

structure of the microlens array

geometrical arrangement of the individual microlenses and feature of the substrate

Note 1 to entry: There are generally two types of arrangements: regular and irregular. Regular can be rectangular, hexagonal or polar regardless of the overlapping of microlenses on the substrate. The specification has to completely describe the arrangement for the microlens array. The lens array positions X_j , Y_j and aperture vertex coordinates are used to define this structure. For regular structures, only the spacing and geometry are to be defined.

3.4.1.2

lens aperture centre position

x, y, z

coordinates of the location of the centre of a given lens in the array

Note 1 to entry: The index j may be added as needed to identify a particular lens number.

Note 2 to entry: The coordinates of the lens aperture centre position are expressed in millimetres.

3.4.1.3

focal spot position

S_x, S_y, S_z

coordinates of the focal spot geometrical positions

Note 1 to entry: The index j may be added to specify a particular microlens.

Note 2 to entry: The focal spot position need not be specified if the array is telecentric and regular.

Note 3 to entry: The coordinates of the focal spot position are expressed in millimetres.

3.4.1.4

focal spot position shift

$\Delta S_x, \Delta S_y, \Delta S_z$

offset distance from the x, y, z coordinates of the lens position to the focal spot position

Note 1 to entry: $\Delta S_x = x - S_x$, $\Delta S_y = y - S_y$, $\Delta S_z = z - S_z$.

Note 2 to entry: The focal spot position shift is expressed in millimetres.

3.4.1.5

pitch

P_x, P_y

distance between the centres of adjacent lenses which can vary across and will vary with direction

Note 1 to entry: P_x, P_y are defined as pitch of x, y direction as shown in [Figure 2](#).

Note 2 to entry: The pitch is expressed in millimetres.

3.4.1.6

lens density

D_n

number of lenses per unit area of the array

Note 1 to entry: The lens density is expressed in millimetres to the power minus two.

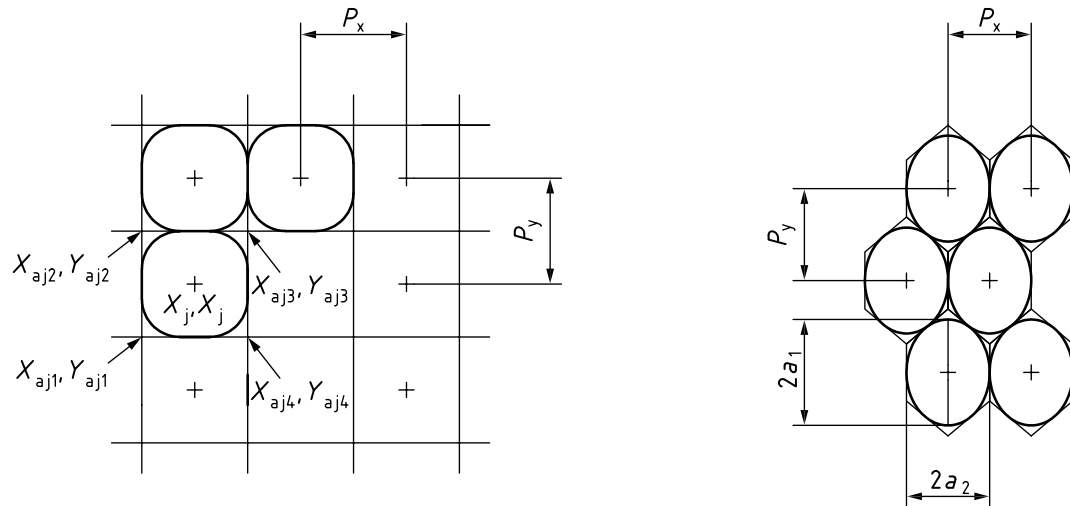

Figure 2 — Arrangement of the microlens array

3.4.1.7

fill factor

ratio of the area of the array occupied by the geometrical aperture of lenses to the total area

3.4.1.8

surface modulation depth

h

peak-to-valley variation of the surface height

Note 1 to entry: For a purely refractive microlens, this will be the same as the lens sag.

Note 2 to entry: The surface modulation depth is expressed in millimetres.

3.4.1.9

physical thickness

T_c

maximum local thickness of the array

Note 1 to entry: The physical thickness is expressed in millimetres.

3.4.1.10

substrate

piece of material on which or in which the microlens array is made

Note 1 to entry: The substrate can be homogenous or laminated. The refractive index and the substrate thickness of the material should be specified.

3.4.1.11

decentration

transverse separation between the optical axes of two or more microlens arrays

3.4.2 Optical properties

3.4.2.1

efficiency

ratio of the optical radiation power that is focused into the useful images to the total optical radiation incident on the array

Note 1 to entry: The definition of useful image will vary from one application to another and has to be defined unambiguously.

3.4.2.2
diffraction limited efficiency

ratio of the incident optical radiation in a plane wave that falls within the area defined by the first minimum of the theoretical diffraction pattern to the total optical radiation incident on the array

3.4.2.3
stray radiation

ratio of optical radiation passing through the lens array that does not fall within the area of a useful image to the total radiation incident on the array

3.4.2.4
common focal plane

plane defined by the mean value of the focal points of all the lenses

3.4.2.5
deviation from common focal plane

measure of the deviation of the individual focal lengths from the common focal plane given by the standard deviation of the focal lengths

Note 1 to entry: The deviation from common focal plane is expressed in micrometres.

3.4.2.6
spectral transmission

variation of optical transmission of the microlens array with wavelength

4 Coordinate system

To describe the radiation propagation in a microlens array, a Cartesian coordinate system is used where the z-axis corresponds to the direction of propagation of the optical radiation and the x-axis and y-axis are on the surface of the substrate, as shown in [Figure 1](#). The fundamental structure of a microlens array is illustrated in [Figure 3](#). The microlenses on the second side can have the same diameter or, as shown in [Figure 4](#), a different diameter to those on the first side.

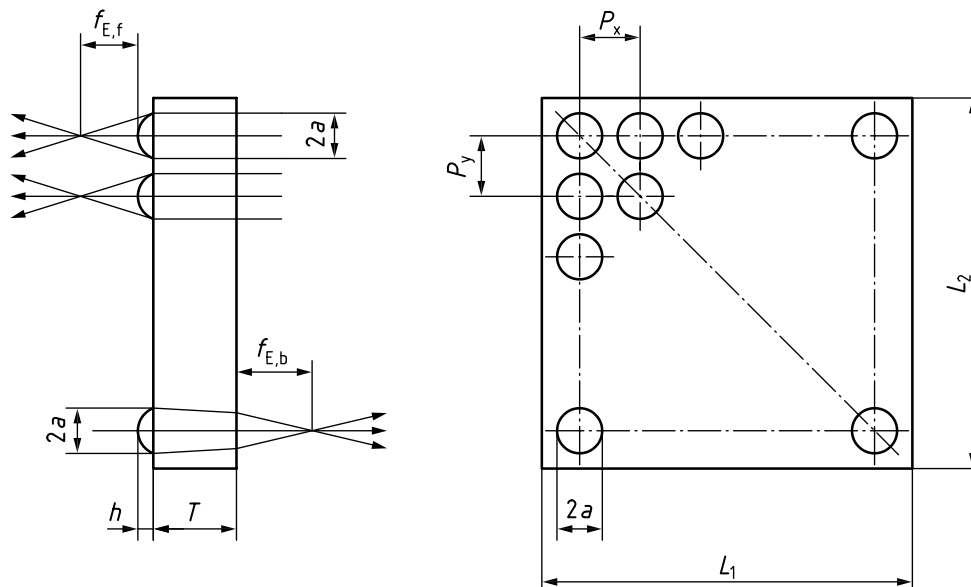

Figure 3 — Fundamental structure of microlens arrays

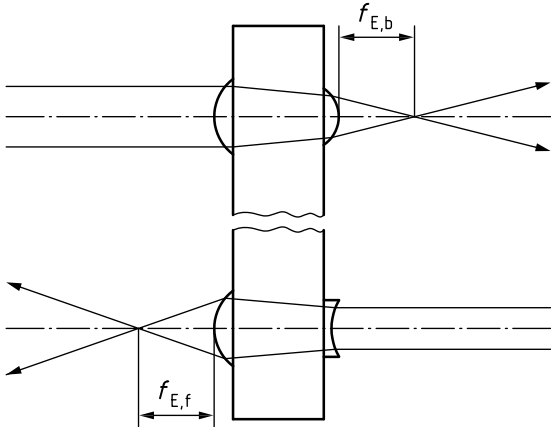
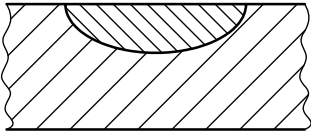
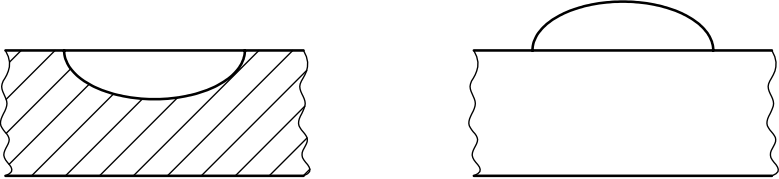

Figure 4 — Substrate with microlens arrays on both sides

5 Properties of individual lenses



a) Microlens with a graded refractive index



b) Surface relief refractive microlens



c) Fresnel microlens

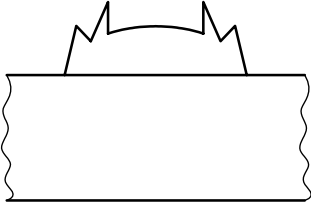

d) Hybrid microlens



e) Diffractive binary-optic microlens

Figure 5 — Five different types of microlens

Microlenses are usually thick lenses in the sense that the thickness of the material is usually a significant fraction of the focal length. In some circumstances, the terminology (used for thick lenses) needs to be expanded in order to take account of the special features of microlenses. Five common types of microlens are illustrated in [Figure 5](#). Microlenses with a graded refractive index, also called GRIN microlenses, are shown in [Figure 5 a\)](#), surface relief refractive microlenses are shown in [Figure 5 b\)](#) and Fresnel microlenses are shown in [Figure 5 c\)](#). Another type of microlens, shown in [Figure 5 d\)](#), is sometimes called a blazed zone plate or hybrid microlens. This focuses light by a combination of refraction and diffraction via concentric curved surfaces.

Diffraction binary-optic microlenses, shown in [Figure 5 e\)](#), focus light by diffraction. They are formed with stepped edges or multiple phase levels (multilevels) that approximate the ideal shape. Standard semiconductor processes such as photolithography and reactive ion-etching can be used to produce them.

In general, the parameters for each microlens can differ from lens to lens. For such cases, an index j is added to the various parameters defining the microlens.

Annex A (informative)

Micro lens array applications (1) — Telecommunications

Optical systems are used extensively in modern telecommunications and micro-optics play a key part. Microlenses are used to collimate light from optical fibres to optical fibres and to couple light from laser diodes into single mode or multimode fibres.

Both graded index (GRIN) microlenses and surface profile microlenses are used, often with aspheric or anamorphic surfaces, according to Reference [6]. In some instances, the ability to interchange channels is required. [Figure A.1](#) shows a microlens array being used to couple light from one array of fibres to another, switching channels in the process.

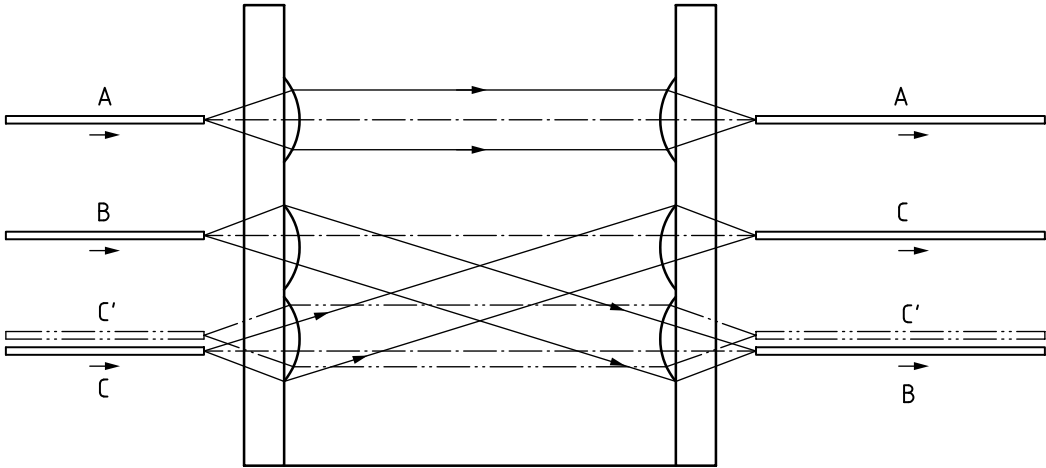

Key
—— fibre-axis

Figure A.1 — Coupling light from one array of optical fibres to another

Annex B (informative)

Microlens array applications (2) — Image sensor arrays

Microlenses enable the optical efficiency of sensor arrays to be maximised. A common application is to enhance the fill-factor in sensor arrays used in digital cameras. [Figure B.1](#) shows a microlens array coupling light into the active areas of a sensor array such as a CCD or CMOS array. Without the microlens array, some of the light would be lost in the non-sensitive areas of the sensor array. The distance between the microlens array and the sensor can vary according to the design. In some cases, this distance is less than the focal length of the microlenses.

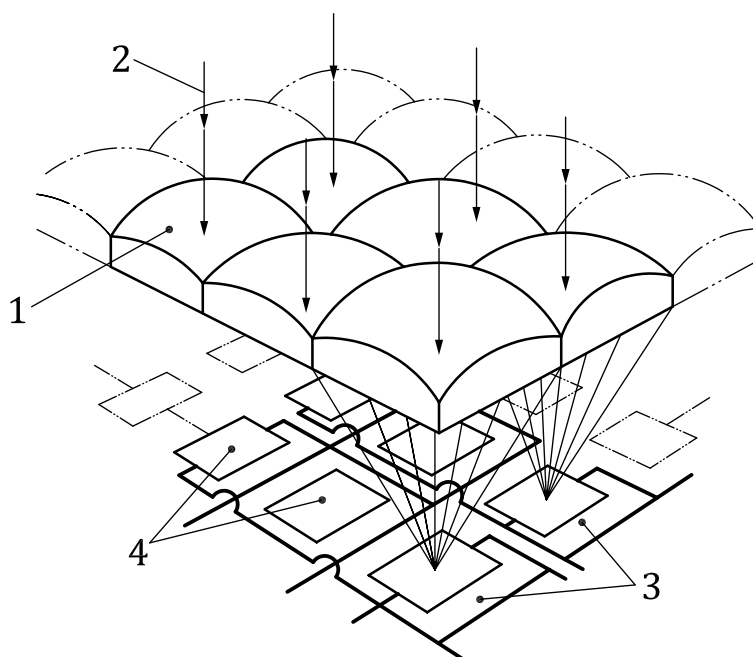

Key

- 1 microlens array
- 2 incident light
- 3 dead areas of the image sensor
- 4 active areas of the image sensor

Figure B.1 — Coupling light to a detector array using an array of microlenses

Annex C (informative)

Microlens array applications (3) — LCD projection panels

Liquid crystal display (LCD) projection panels are an important application for microlens arrays. Microlenses enable the optical efficiency of compact projection devices to be maximized.

Compact electronic projection devices are made using active matrix technology. The picture elements are defined by liquid-crystal cells that change the direction of polarization of light passing through them in response to electrical voltages produced by an array of thin-film transistors (TFT). The variations in transmitted intensity that make up the picture occur when the polarized light encounters another polarizing layer on the face of the display.

The matrix structure means the array of conductors and transistors can block a significant proportion of the incident light. Microlenses are used to improve the light transmission by focusing the light through the unobstructed portions of the arrays, according to References [7] and [8]. [Figure C.1](#) shows an array of microlenses being used to focus light through the gaps between the black matrix and the TFT array.

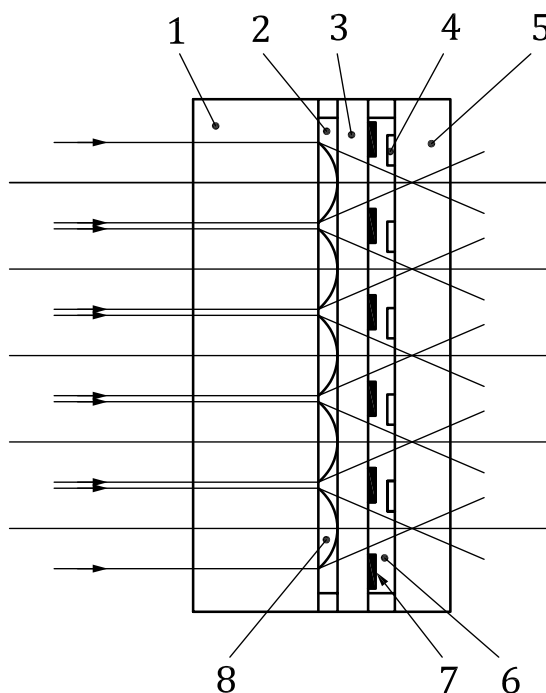

Key

1	microlens substrate	5	TFT substrate
2	low refractive index medium, resin for example	6	LCD
3	cover glass	7	black matrix
4	TFT	8	microlens

Figure C.1 — Cross-section of an LCD projection panel

Annex D (informative)

Microlens array applications (4) — Wavefront sensors

D.1 Shack-Hartmann wavefront sensor

Wavefront sensing is another important application for microlens arrays. Microlens arrays are used in the Shack-Hartmann sensor to enable the shape of an incident wavefront to be calculated from measurements of the positions of the focused spots produced by the array^[9]. The sensor can be made with a high sensitivity and is commonly used with adaptive optic systems where a deformable mirror is adjusted to optimize the shape of a wavefront^[10].

[Figure D.1](#) shows a Shack-Hartmann sensor. The microlens array divides the incident wavefront into a number of small areas, each of which is focused to a spot on a detector array. If a plane reference wavefront is used at normal incidence, the spots are formed on the axes of the microlenses. If the test wavefront is non-planar, the spots are formed away from the axes. A detector array such as a charge-coupled device (CCD) is commonly used to capture the images of the multiple spots. This allows the positions of the centroids of the spots to be determined with precision.

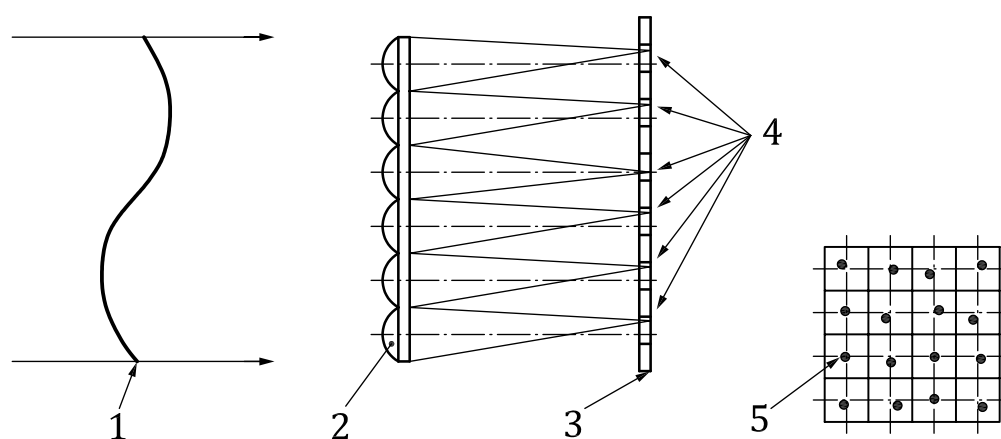

Key

- 1 wavefront
- 2 microlens array
- 3 image sensor (detector array)
- 4 focused spots at detector array
- 5 spot position

Figure D.1 — Array of microlenses is used to sample an incident wavefront

The transverse positions of the spots are related to the local slopes of the wavefront in the regions of the lens apertures. The form of the wavefront can be calculated from the slope data using a small computer and dedicated software. In practice, it is usually necessary to expand or contract the dimensions of the wavefront to match the dimensions of the microlens array and CCD array, as shown in the schematic layout in [Figure D.2](#).

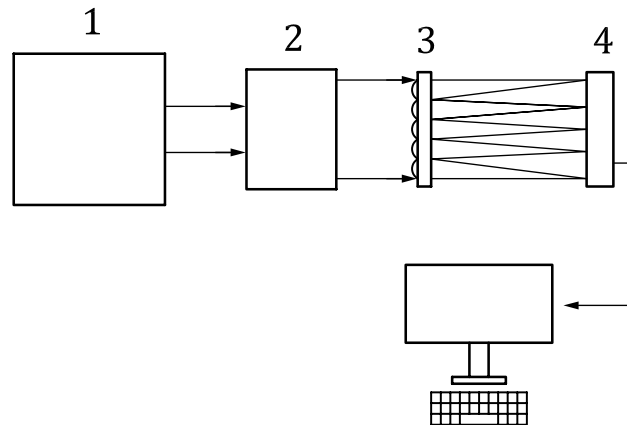

Key

- 1 source of wavefront
- 2 beam expansion or compression optics
- 3 microlens array
- 4 detector array

Figure D.2 — Schematic arrangement for wavefront measurement using Shack-Hartmann technique

The lateral resolution of the wavefront is limited by the pitch of the microlenses in the array. Wavefront measurement accuracy is limited by the accuracy with which the centroids of the focused spots can be determined.

Compared with some other wavefront sensors, this system has the advantage of good optical efficiency and no moving mechanical parts. Other advantages include the speed of measurement and the fact that it can be used with low coherence wavefronts.

D.2 Other wavefront sensors

Microlens arrays are also used in another type of wavefront sensing system. Here, the shape of an incident wavefront is calculated from measurements of the axial variation of intensity of an array of spots generated in the focal plane of a microlens array. The relative intensity of the focused spots is monitored in synchronism with a deformable membrane mirror, alternating in shape between concave and convex, which introduces changes to the curvature of the wavefront generating the spots^[11]. The sensor is used with a high-speed detection system and has been applied to astronomical imaging. Adaptive optic systems are used in telescopes to overcome atmospheric disturbances and signals from wavefront measurements are fed to a deformable telescope mirror which is adjusted to optimize the shape of an incident wavefront^[12].

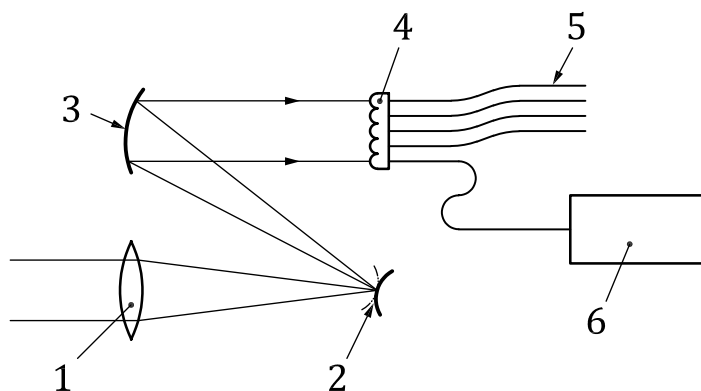

- Key**
- 1 lens
 - 2 deformable mirror
 - 3 mirror
 - 4 microlens array
 - 5 optical fibres
 - 6 sensors

Figure D.3 — Schematic arrangement for wavefront measurement

[Figure D.3](#) shows a schematic diagram for the wavefront curvature sensor. The incident wavefront is focused by a lens to a deformable membrane mirror which oscillates between concave and convex. The wavefront is then reflected by another mirror to the microlens array.

The microlens array divides the incident wavefront into a number of small areas, each of which is focused to a spot. The light in the spots is collected using an array of optical fibres and guided to high-speed detection sensors. Movement in the membrane mirror enables the spots to scan the collection fibres and intensity measurements are related to the corresponding positions of the mirror. The wavefront calculations are made from data recorded when each sensor gives a maximum output signal.

Sensors with high sensitivity and high response, such as avalanche photo diodes are commonly used to detect the light in the incident spots. In the astronomy application, the wavefront calculations are fed back to a segmented deformable mirror in the telescope.

Annex E (informative)

Microlens array applications (5) — Stereo displays

Lenticular lens arrays or arrays of spherical microlenses are used in 3D television displays and digital cameras for 3D photography. They enable stereoscopic and 3D images to be produced from information recorded electronically or in photographic film.

One method for displaying stereo images involves overlaying and interlacing two or more images of a scene, each image being recorded from a different view point. With an LCD screen, alternate columns of pixels are used to make up each of a stereo pair of interlaced stereo images. [Figure E.1](#) shows in cross-section a lenticular lens array used to sample the interlaced images and steer light from pairs of images to the associated left and right eyes of the observer. Each image is viewed by one eye through alternate lenses in the lenticular array and the stereoscopic image is formed in the mind of the observer.

In some designs, multiple views of the object are recorded and the viewing pupil is large enough to allow the observer to select other stereo pairs and see parallax effects in the image.

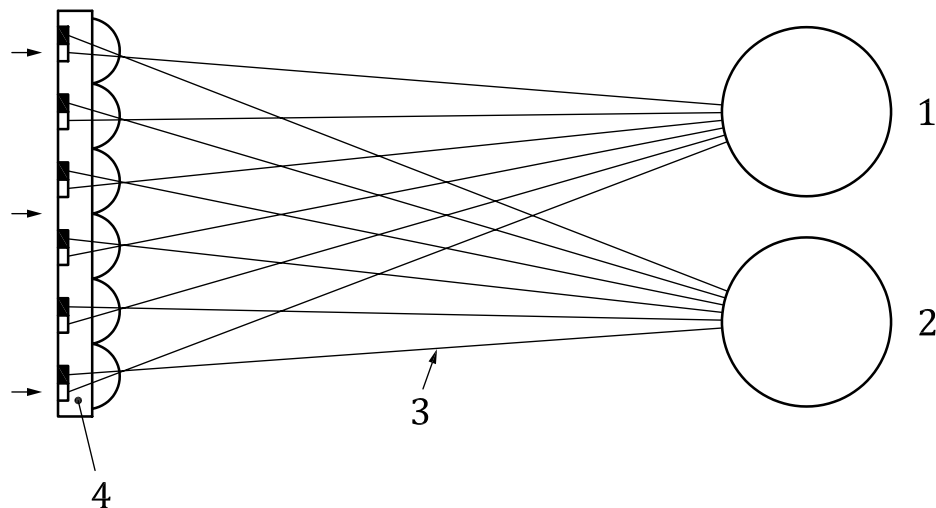

Key

- 1 right eye
- 2 left eye
- 3 lenticular lens array defines viewing zones
- 4 LCD with interlaced images

Figure E.1 — Viewing a stereo display using a lenticular lens array

Annex F (informative)

Microlens array applications (6) — 3D imaging and light-field cameras

For three-dimensional images that exhibit parallax and depth of focus, arrays of spherical microlenses are used to record and reconstruct “integral” images. Lippmann introduced the term “integral” imaging in 1908 and the technique was developed using photographic film as the recording medium^[13].

[Figure F.1](#) shows an array of small images, of a larger three-dimensional object, formed by an array of microlenses and recorded in photographic emulsion. To reconstruct the image, the individual small images are replayed by reversing the direction of illumination. The converging beams then overlap and integrate to form a three-dimensional image which can be viewed from a range of directions.

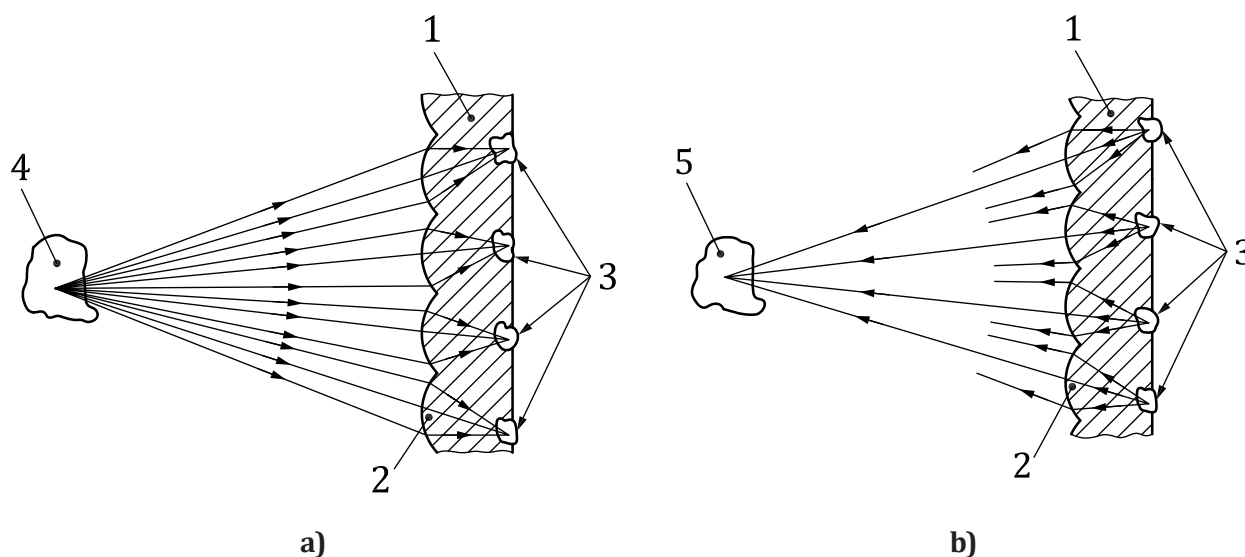

Key

- 1 photographic film
- 2 lenses
- 3 images
- 4 object
- 5 reconstruction

Figure F.1 — Recording and reconstructing an integral three-dimensional image using microlenses

More recently, light-field cameras have been developed. The technique of integral photography has been extended using electronic sensor arrays and extensive data processing to produce an electronic camera that records and reconstructs the wavefront from an object, as shown in [Figure F.2](#). This enables a light field to be calculated and a plane of focus for a section of the 3D image to be defined after exposure^[14]. This type of camera is sometimes known as a plenoptic camera.

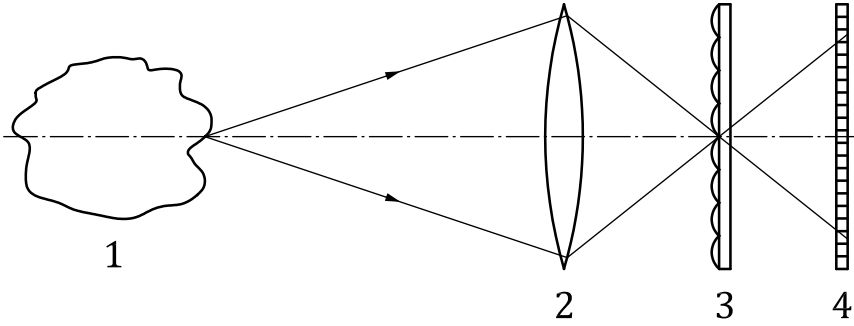

Key

- 1 3D object
- 2 relay lens
- 3 microlens array
- 4 sensor array

Figure F.2 — Schematic concept of a light-field camera

Bibliography

- [1] Microoptics, 2nd, Revised and Enlarged Edition, by Stefan Sinzinger, Jürgen Jahns, pp. 447. ISBN: 978-3-527-60632-0, Mar 2006
- [2] Gabor UK patent 541 753 (1940)
- [3] STOLLBERG K., BRÜCKNER A., DUPARRÉ J., DANNBERG P., BRÄUER A., TÜNNERMANN A. *Opt. Express*. 2009 Aug 31, **17** (18) pp. 15747–15759
- [4] SHI P et al. Micro-prism stack beam shaper for high power laser diode array. *Acta Opt. Sin.* 2000, **20** (11) pp. 1544–1547
- [5] SIEKKINEN J. YANG X.. US patent US200301077 Micro mirror array (2003)
- [6] RAGUIN D. et al. Anamorphic and aspheric microlenses and microlens arrays for telecommunication applications. Optical Fibre Communication Conference and Exhibit. OFC, Vol. 1, 2001, pp. ISBN: 978-3-527-60632-0, Mar 2006, MK1
- [7] BORRELLI. N F Efficiency of microlens arrays for projection LCD. Proceedings 44th Electronic Components and Technology IEEE (1994), pp. 338-345
- [8] HAMADA E, FUNADA F, HIJIKIGAWA M, AWANE K Brightness enhancement of a LCD projector by a planar microlens array. Society of Information Display, SID, Nov 1991 Boston MA
- [9] SHACK RV, & PLATT BC Use of a lenticular Hartmann screen. *JOSA* 656 (1971)
- [10] PLATT B.C., SHACK R History and principles of Shack-Hartmann wavefront sensing. *J. Refract. Surg.* 2001 Sept/Oct, **17** pp. S573–S577
- [11] RODDIER F. Curvature sensing and compensation: a new concept in adaptive optics. *Appl. Opt.* 1988, **27** (7) pp. 1223–1225
- [12] YUTAKA HAYANO et al., Commissioning status of Subaru laser guide star adaptive optics system. Proc. SPIE 7736. *Adaptive Optics Systems II*. 2010 July 27, **II** p. 77360N
- [13] LIPPMANN G, Epreuves reversibles. Photographies integrals, *Comptes Rendus Acad. Sci.* 1908, **146** pp. 446–451
- [14] NG R Lightfield photography with a hand-held plenoptic camera. Stanford Tech Report CTSR 2005-02

Bureau of Indian Standards

BIS is a statutory institution established under the *Bureau of Indian Standards Act, 2016* to promote harmonious development of the activities of standardization, marking and quality certification of goods and attending to connected matters in the country.

Copyright

BIS has the copyright of all its publications. No part of these publications may be reproduced in any form without the prior permission in writing of BIS. This does not preclude the free use, in the course of implementing the standard, of necessary details, such as symbols and sizes, type or grade designations. Enquiries relating to copyright be addressed to the Head (Publication & Sales), BIS.

Review of Indian Standards

Amendments are issued to standards as the need arises on the basis of comments. Standards are also reviewed periodically; a standard along with amendments is reaffirmed when such review indicates that no changes are needed; if the review indicates that changes are needed, it is taken up for revision. Users of Indian Standards should ascertain that they are in possession of the latest amendments or edition by referring to the website-www.bis.gov.in or www.standardsbis.in.

This Indian Standard has been developed from Doc No.: PGD 39 (24217).

Amendments Issued Since Publication

Amend No.	Date of Issue	Text Affected

BUREAU OF INDIAN STANDARDS

Headquarters:

Manak Bhavan, 9 Bahadur Shah Zafar Marg, New Delhi 110002

Telephones: 2323 0131, 2323 3375, 2323 9402

Website: www.bis.gov.in

Regional Offices:

Central : 601/A, Konnectus Tower -1, 6th Floor,
DMRC Building, Bhavbhuti Marg, New
Delhi 110002

Telephones

{ 2323 7617

Eastern : 8th Floor, Plot No 7/7 & 7/8, CP Block, Sector V,
Salt Lake, Kolkata, West Bengal 700091

{ 2367 0012
2320 9474

Northern : Plot No. 4-A, Sector 27-B, Madhya Marg,
Chandigarh 160019

{ 265 9930

Southern : C.I.T. Campus, IV Cross Road, Taramani, Chennai 600113

{ 2254 1442
2254 1216

Western : Manakalya, 4th Floor, NTH Complex (W Sector), F-10, MIDC, Andheri
(East), Mumbai 400093

{ 283 25838

Branches : AHMEDABAD, BENGALURU, BHOPAL, BHUBANESHWAR, CHANDIGARH, CHENNAI, COIMBATORE, DEHRADUN, DELHI, FARIDABAD, GHAZIABAD, GUWAHATI, HARYNA, HUBLI, HYDERABAD, JAIPUR, JAMMU & KASHMIR, JAMSHEDPUR, KOCHI, KOLKATA, LUCKNOW, MADURAI, MUMBAI, NAGPUR, NOIDA, PARWANOO, PATNA, PUNE, RAIPUR, RAJKOT, SURAT, VIJAYAWADA.