**Metallic powders — Determination of
green strength by transverse rupture
of rectangular compacts**

*Poudres métalliques — Détermination de la résistance à la rupture
transversale de comprimés rectangulaires à cru*





COPYRIGHT PROTECTED DOCUMENT

© ISO 2023

All rights reserved. Unless otherwise specified, or required in the context of its implementation, no part of this publication may be reproduced or utilized otherwise in any form or by any means, electronic or mechanical, including photocopying, or posting on the internet or an intranet, without prior written permission. Permission can be requested from either ISO at the address below or ISO's member body in the country of the requester.

ISO copyright office
CP 401 • Ch. de Blandonnet 8
CH-1214 Vernier, Geneva
Phone: +41 22 749 01 11
Email: copyright@iso.org
Website: www.iso.org

Published in Switzerland

Contents

	Page
Foreword	iv
1 Scope	1
2 Normative references	1
3 Terms and definitions	1
4 Principle	1
5 Apparatus	1
6 Sampling	4
7 Procedure	4
7.1 Cleaning of the die and punches.....	4
7.2 Powder testing conditions.....	4
7.3 Lubrication.....	5
7.3.1 General.....	5
7.3.2 Die wall lubrication.....	5
7.3.3 Lubrication of powder.....	5
7.4 Compacting and ejection.....	5
7.5 Compacting pressure.....	6
7.6 Determination of density.....	7
7.7 Determination of breaking force.....	7
7.7.1 General.....	7
7.7.2 Method 1 — Using a compression testing machine.....	7
7.7.3 Method 2 — Using a loading beam device (see Figure 3).....	7
8 Expression of results	7
9 Test report	8

Foreword

ISO (the International Organization for Standardization) is a worldwide federation of national standards bodies (ISO member bodies). The work of preparing International Standards is normally carried out through ISO technical committees. Each member body interested in a subject for which a technical committee has been established has the right to be represented on that committee. International organizations, governmental and non-governmental, in liaison with ISO, also take part in the work. ISO collaborates closely with the International Electrotechnical Commission (IEC) on all matters of electrotechnical standardization.

The procedures used to develop this document and those intended for its further maintenance are described in the ISO/IEC Directives, Part 1. In particular, the different approval criteria needed for the different types of ISO document should be noted. This document was drafted in accordance with the editorial rules of the ISO/IEC Directives, Part 2 (see www.iso.org/directives).

ISO draws attention to the possibility that the implementation of this document may involve the use of (a) patent(s). ISO takes no position concerning the evidence, validity or applicability of any claimed patent rights in respect thereof. As of the date of publication of this document, ISO had not received notice of (a) patent(s) which may be required to implement this document. However, implementers are cautioned that this may not represent the latest information, which may be obtained from the patent database available at www.iso.org/patents. ISO shall not be held responsible for identifying any or all such patent rights.

Any trade name used in this document is information given for the convenience of users and does not constitute an endorsement.

For an explanation of the voluntary nature of standards, the meaning of ISO specific terms and expressions related to conformity assessment, as well as information about ISO's adherence to the World Trade Organization (WTO) principles in the Technical Barriers to Trade (TBT), see www.iso.org/iso/foreword.html.

This document was prepared by Technical Committee ISO/TC 119, *Powder metallurgy*, Subcommittee SC 2, *Sampling and testing methods for powders (including powders for hardmetals)*, in collaboration with the European Committee for Standardization (CEN) Technical Committee CEN/SS M11, *Powder metallurgy*, in accordance with the Agreement on technical cooperation between ISO and CEN (Vienna Agreement).

This third edition cancels and replaces the second edition (ISO 3995:1985), which has been technically revised.

The main changes are as follows:

- allowing automated compacting sequence in [7.4](#);
- adding second compacting pressure option and tighter tolerance in [7.5](#);
- mandatory reporting of lubrication technique and lubrication details in Clause [9](#);
- replacing stearic acid by synthetic wax;
- removing the use of solvent.

Any feedback or questions on this document should be directed to the user's national standards body. A complete listing of these bodies can be found at www.iso.org/members.html.

Metallic powders — Determination of green strength by transverse rupture of rectangular compacts

1 Scope

This document specifies a method for the determination of green strength by measuring the transverse rupture strength of compacts of rectangular cross-section.

2 Normative references

There are no normative references in this document.

3 Terms and definitions

No terms and definitions are listed in this document.

ISO and IEC maintain terminology databases for use in standardization at the following addresses:

- ISO Online browsing platform: available at <https://www.iso.org/obp>
- IEC Electropedia: available at <https://www.electropedia.org/>

4 Principle

Subjection of a compact pressed from metallic powder to a uniformly increasing transverse force under controlled conditions until fracture occurs. Determination of the transverse rupture strength, or green strength as used herein, as the stress, calculated from the flexure formula, required to break the compact as a simple beam supported near the ends and applying the force midway between the fixed centre of supports.

The green strength is determined on compacts either having a particular density or after compaction at a specific compacting pressure.

5 Apparatus

5.1 Die, preferably of cemented carbide or alternatively of tool steel, and two punches for producing rectangular test pieces with dimensions according to [Clause 6](#).

All mating parts shall be fitted and lapped. An example of a design for tooling is shown in [Figure 1](#).

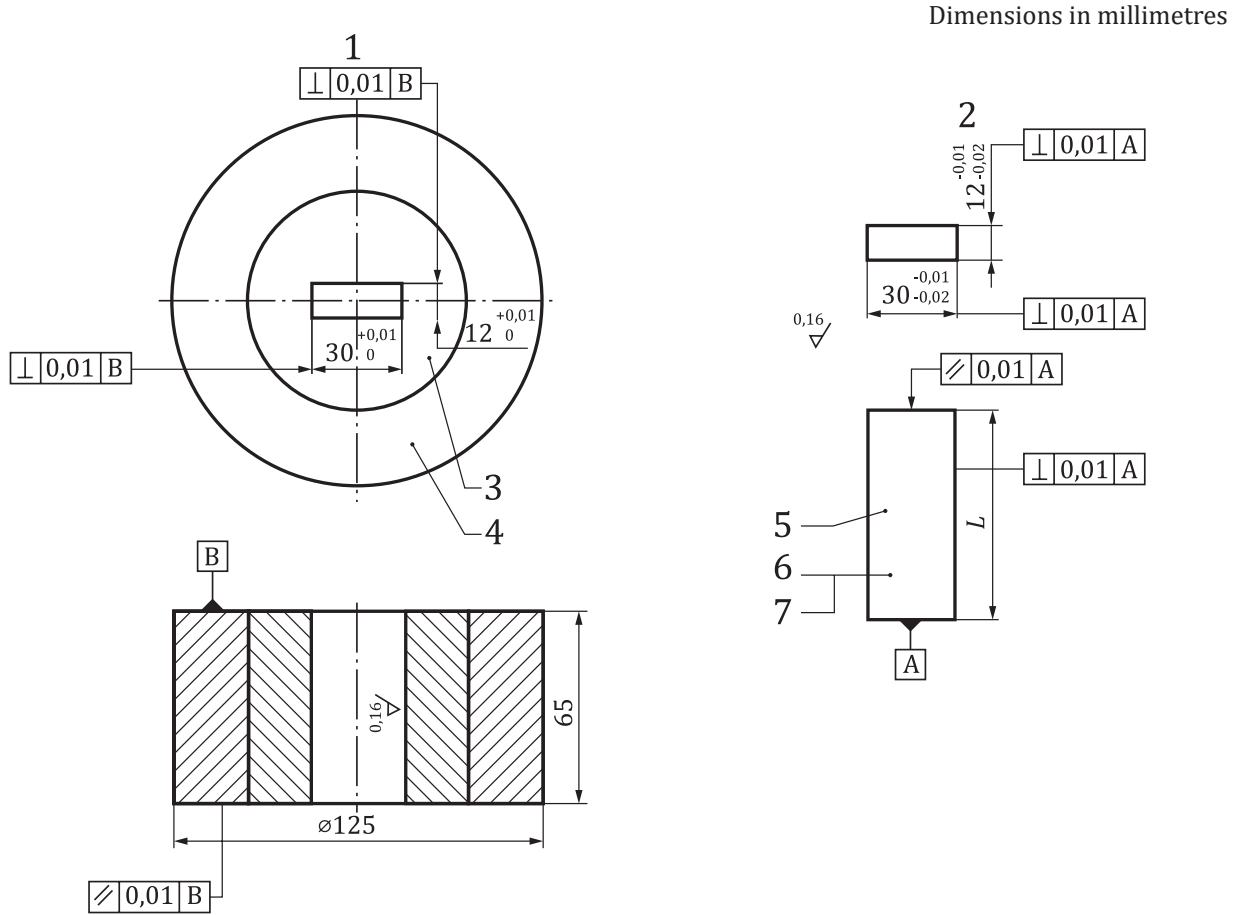

Key

- | | |
|--------------------|-----------------------|
| 1 die | 5 steel HRC 60 to 62 |
| 2 punches | 6 upper punch; L = 25 |
| 3 cemented carbide | 7 lower punch; L = 70 |
| 4 shrink ring | |

Figure 1 — Example of tooling to produce a rectangular test piece

5.2 Press, capable of applying forces up to about 300 kN with a minimum accuracy of $\pm 2\%$ and adjustable to permit an even increase of the force at a rate no higher than 50 kN/s.

5.3 Balance, capable of weighing the compacts to an accuracy of $\pm 0,01$ g.

5.4 Micrometer or other measuring device, suitable for measuring the dimensions of the compacts to an accuracy of $\pm 0,01$ mm.

5.5 Fixture for testing, having two support cylinders (rollers) with a fixed distance between them and a load cylinder (roller).

All three cylinders shall be $3,0\text{ mm} \pm 0,1\text{ mm}$ in diameter and shall be made of hardened steel with a hardness of at least 700 HV, or of hardmetal.

The cylinders shall be mounted parallel and the distance between the centres of the support cylinders shall be $25\text{ mm} \pm 0,2\text{ mm}$ or $25,4\text{ mm} \pm 0,2\text{ mm}$, measured with an accuracy of $\pm 0,1\text{ mm}$. The load cylinders shall be mounted midway between the support cylinders.

The mounting of the cylinders shall be such as to account for the permitted deviation from parallelism of the top and bottom faces of the test piece.

A diagrammatic arrangement of a typical test fixture is shown in [Figure 2](#).

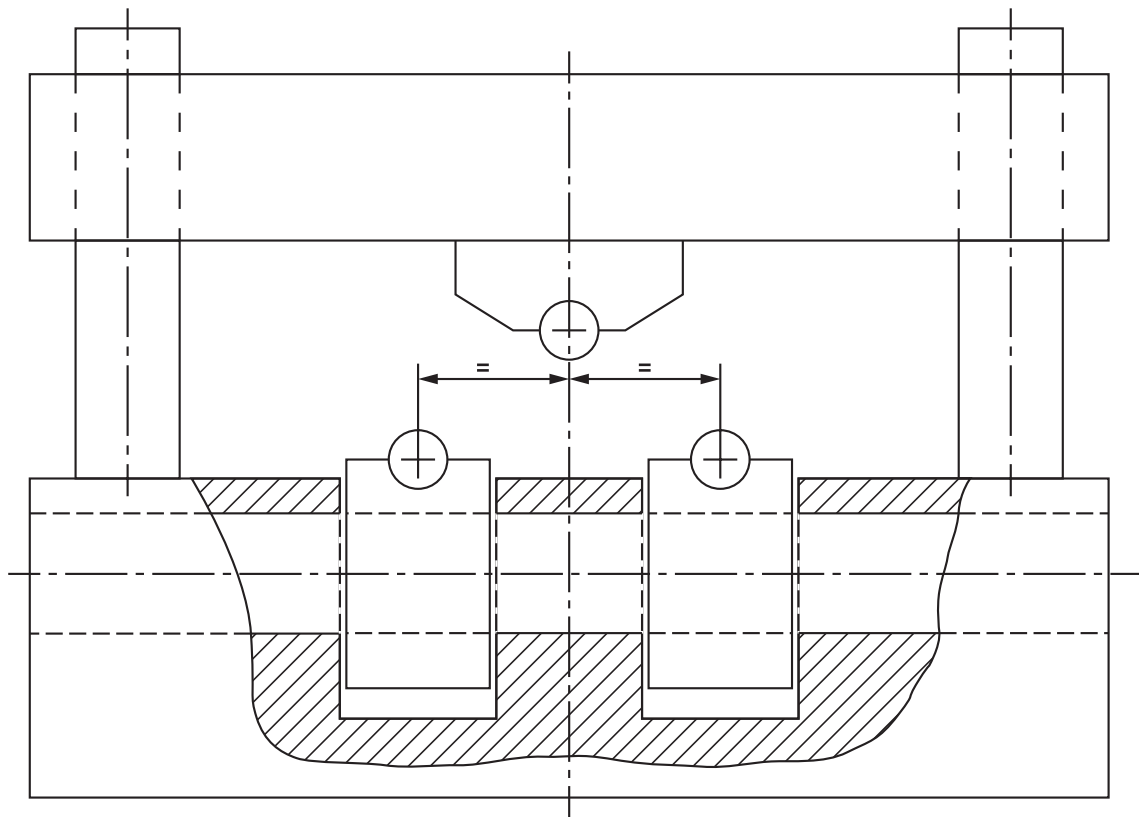

Figure 2 — Diagram of test fixture

5.6 Loading device. Loading devices shall be either of the devices in [5.6.1](#) or [5.6.2](#).

5.6.1 A compression testing machine capable of determining the breaking force with a minimum accuracy of ± 2 N.

5.6.2 A loading beam apparatus to properly locate the test piece and which is capable of applying a breaking force through a lever arrangement. The applied force on the test piece shall be calculated to an accuracy of ± 2 N.

Note The applied force can be exerted by various systems, an example of which is given in [Figure 3](#).

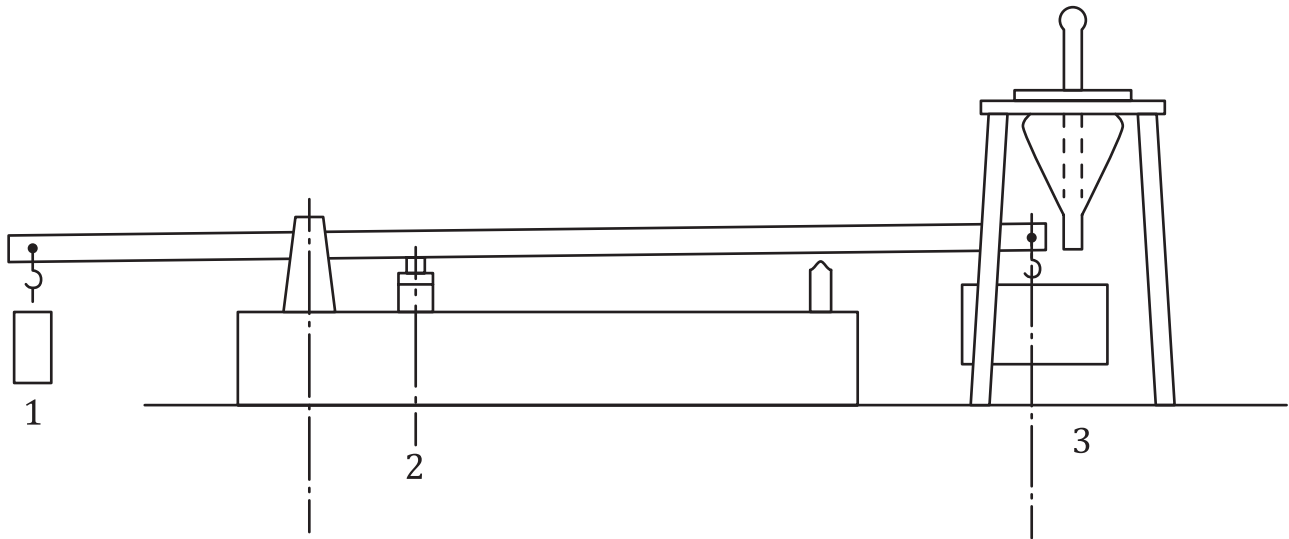

Key

- 1 counterbalance
- 2 test fixture
- 3 load

Figure 3 — Example of loading beam apparatus

6 Sampling

The quantity of the test sample shall be chosen to give three test pieces with the dimensions 10 mm to 13 mm wide, at least 30 mm long and 5,5 mm to 6,5 mm thick. The thickness of the test piece shall be uniform within 0,1 mm over the distance between supports. If necessary, preliminary tests should be made in order to establish the quantity of powder which is needed to fulfil this requirement.

7 Procedure

7.1 Cleaning of the die and punches

Wipe the die cavity and the punches with soft and clean paper.

7.2 Powder testing conditions

7.2.1 Powders which do not contain a lubricant can be compacted in the following ways:

- a) in a dry die

Note seizure and excessive die wear may occur, particularly at high compacting pressures;

- b) in a die with lubricated walls (see [7.3.2](#));
- c) after admixing a lubricant (see [7.3.3](#)) and in a dry die.

7.2.2 Powders which contain a lubricant can be compacted the following ways:

- a) in a dry die;
- b) after admixing additional lubricant (see [7.3.3](#)) and in a dry die.

7.3 Lubrication

7.3.1 General

Lubrication shall be either of the methods in [7.3.2](#) or [7.3.3](#) or a combination of them.

7.3.2 Die wall lubrication

Apply to the die walls a mixture or a solution of a lubricant in a volatile liquid, for example 100 g of zinc stearate in 1 000 cm³ of acetone. After any excess liquid has drained away, allow the solution adhering to the walls to evaporate leaving a thin layer of lubricant.

7.3.3 Lubrication of powder

Lubricate the powder to be tested by thoroughly mixing into it a quantity (for example 0,5 % to 1,5 %) of a suitable solid lubricant (for example zinc stearate or synthetic wax).

7.4 Compacting and ejection

Insert the lower punch into the die cavity. Position the die to the desired filling height by using supporting spacers between the die and the foot of the lower punch. Pour the sample into the die cavity, taking the usual precautions to ensure that the powder is uniformly distributed in the die cavity. Position the upper punch and place the die with the punches between the platens of the press. Apply and release a preliminary force of approximately 20 kN. Remove the spacers supporting the die. If the die is supported by springs, or in some similar way, it is not necessary to apply the preliminary force.

Apply the final force at a constant rate which shall not exceed 50 kN/s.

Eject the compact from the die by means of the lower punch.

The procedure of compacting and ejection is exemplified in [Figure 4](#).

A press tool built into an adaptor where the powder is filled into the tool die by a fill shoe and compaction and ejection is carried out in an automated sequence by the press is also a viable option. With such arrangement the requirement maximum load rate is still valid. The tool arrangement shall enable to compact the specimen uniaxially by means of supporting the die on springs, or alternatively, by controlling the motion of the tool die in relation to the movement of the upper punch.

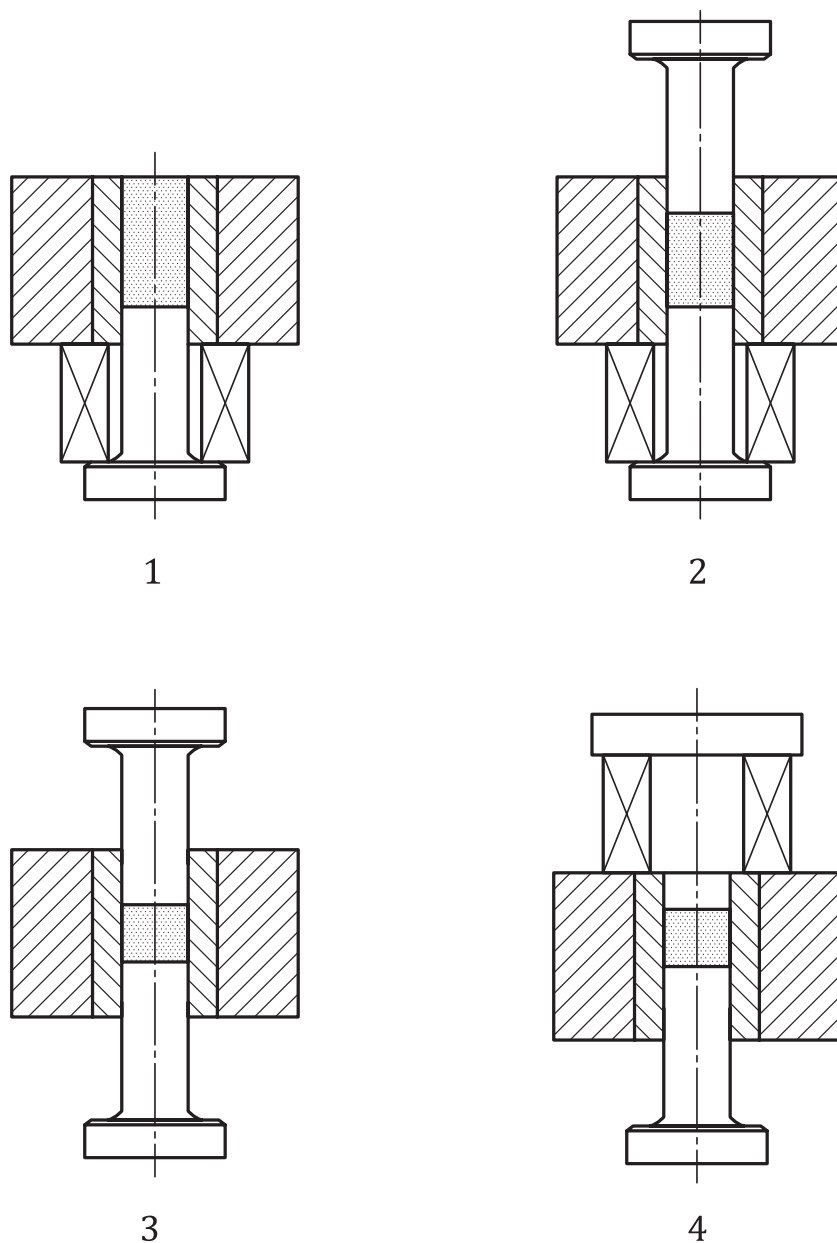

Key

- 1 filling
- 2 pre-compacting
- 3 compacting
- 4 ejection

Figure 4 — Procedure of compacting and ejection

7.5 Compacting pressure

Green strength shall be determined at a given pressure or density following agreement between supplier and customer. In the first case the recommended pressure is 400 N/mm² or 600 N/mm². In the second case, when test pieces are pressed to a given density, the maximum deviation between the three test pieces shall not exceed ±0,05 g/cm³ from target density.

7.6 Determination of density

Measure the length, width and thickness of the test piece in the plane of application of the force to the nearest 0,01 mm. Determine the mass and the volume (calculated from the average value of dimensions).

7.7 Determination of breaking force

7.7.1 General

Break the test piece under controlled conditions using either a compression testing machine or a loading beam device.

7.7.2 Method 1 — Using a compression testing machine

Position the test piece in the transverse rupture test fixture (see [Figure 2](#)) so that it is centrally located and perpendicular to the axis of the support cylinders. Place the fixture between the platens of the testing machine and apply a compressive force at a uniform rate such that the test piece fractures within a time not less than 10 s. Record the breaking force to the nearest 2 N.

7.7.3 Method 2 — Using a loading beam device (see [Figure 3](#))

Adjust the balance of the beam so that it is level. Position the test piece in the loading beam device so that it is centrally located and perpendicular to the axis of the support cylinders. Increase the load at a uniform rate such that the test piece fractures within a time not less than 10 s.

Determine the input force to the nearest 2 N.

NOTE When a container and shot are used, the beam should be balanced with the container in position. The load exerted is then calculated from the mass of the shot only.

8 Expression of results

8.1 Calculate the density of the test piece from its mass and volume. Calculate the arithmetical mean of the determination on three different test pieces to the nearest 0,05 g/cm³.

8.2 The green strength S , expressed in N/mm², is given by [Formula \(1\)](#):

$$S = \frac{3 \times P \times L}{2 \times t^2 \times w} \quad (1)$$

where

- P is the force, in N, required to rupture;
- L is the length, in mm, of span of the fixture;
- t is the thickness, in mm, of the test piece;
- w is the width, in mm, of the test piece.

8.3 Calculate the arithmetical mean of the three determinations rounded to the nearest 0,2 N/mm² for values up to and including 10 N/mm² and to the nearest 0,5 N/mm² for values greater than 10 N/mm².

9 Test report

The test report shall include the following information:

- a) a reference to this document, i.e. ISO 3995:2023;
- b) all details necessary for identification of the test sample;
- c) the lubrication technique: die wall lubrication, admixed powder lubrication or other technique. In case of admixed powder lubrication, indicate the type and amount of lubricant;
- d) the density of the test pieces or the compacting pressure;
- e) compacting die material (tool steel or cemented carbide);
- f) the result obtained;
- g) all operations not specified by this document (i.e. ISO 3995:2023), or regarded as optional;
- h) details of any occurrence which may have affected the result.

