

परिवहनीय गैस सिलिंडर — जोड़ रहित  
एल्यूमिनियम मिश्रधातु के गैस सिलिंडरों के  
आवधिक निरीक्षण एवं परीक्षण

(पहला पुनरीक्षण)

Transportable Gas Cylinders —  
Periodic Inspection and Testing of  
Seamless Aluminium Alloy Gas  
Cylinders

(First Revision)

ICS 23.020.30

© BIS 2024



भारतीय मानक ब्यूरो  
BUREAU OF INDIAN STANDARDS  
मानक भवन, 9 बहादुर शाह ज़फर मार्ग, नई दिल्ली - 110002  
MANAK BHAVAN, 9 BAHADUR SHAH ZAFAR MARG  
NEW DELHI - 110002

[www.bis.gov.in](http://www.bis.gov.in) [www.standardsbis.in](http://www.standardsbis.in)

## FOREWORD

This Indian Standard (First Revision) was adopted by the Bureau of Indian Standards, after the draft finalized by the Gas Cylinders Sectional Committee had been approved by the Mechanical Engineering Division Council.

This standard was originally issued in 2013. This standard is being revised again to keep pace with the latest technological developments and international practices. Also, in this revision, the standard has been brought into the latest style and format of Indian Standards, and references of Indian Standards, wherever applicable have been updated. BIS certification marking clause has been modified to align with the revised *Bureau of Indian Standards Act, 2016*. The following major modifications have been incorporated in this revision of the standard:

- a) Intervals for periodic inspections and tests for different gas types has been specified;
- b) Internal visual inspections test has been revised;
- c) Rejection limits relating to physical and material defects in the cylinder shell have been added; and
- d) Rejection criteria for corrosion of the cylinder wall have been added.

The purpose of this standard is to specify the requirements for periodic inspection and testing of seamless aluminium alloy transportable gas cylinders (single or those from bundles) intended for compressed and liquefied gases under pressure, of water capacity from 0.5 litre up to 150 litres.

This standard has been formulated as a guide to cylinder users and fillers for establishing their own cylinder inspection procedures and standards. It is of, necessity, general in nature although some specific limits are recommended. It should be distinctly understood that it shall not cover all circumstances for each individual cylinder type. Each cylinder user is expected to modify them to suit his own cylinder design or the conditions of use that may exist in his own service. Rejection or acceptance for continued use in accordance with their cylinders are or are not dangerous or subject to impending failure, but represents practice which has been satisfactory to a cross-section of the industry.

Experience in the inspection of cylinders is an important factor in determining the acceptability of a given cylinder for continued service. Users lacking this experience and having doubtful cylinders should return them to a manufacturer of the same type of cylinders for re-inspection.

In the formulation of this standard, considerable assistance has been derived from ISO 18119 : 2018 ‘Gas cylinders — Seamless steel and seamless aluminium-alloy gas cylinders and tubes — Periodic inspection and testing’

While implementing this standard, the manufacturer and the inspection agency shall ensure compliance with statutory regulations.

Information on gas cylinders manufactured according to national regulations is given in [Annex A](#).

The composition of the Committee responsible for the formulation of this standard is given in [Annex K](#).

For the purpose of deciding whether a particular requirement of this standard is complied with, the final value, observed or calculated, expressing the result of a test or analysis, shall be rounded off in accordance with IS 2 : 2022 ‘Rules for rounding off numerical values (*second revision*)’. The number of significant places retained in the rounded off value should be the same as that of the specified value in this standard.

*Indian Standard*

# TRANSPORTABLE GAS CYLINDERS — PERIODIC INSPECTION AND TESTING OF SEAMLESS ALUMINIUM ALLOY GAS CYLINDERS

( *First Revision* )

## 1 SCOPE

**1.1** This standard specifies the requirements for periodic inspection and testing of seamless aluminium alloy transportable gas cylinders (single or those from bundles) intended for compressed and liquefied gases under pressure, of water capacity from 0.5 litre up to 150 litres. This standard also specifies the requirements for periodic inspection and testing to verify the integrity of such gas cylinders to be reintroduced into service for a further stipulated time period as specified in gas cylinder rules. It also defines a procedure to qualify existing gas cylinders for free movement between India and other countries.

**1.2** This standard does not apply to periodic inspection and testing of acetylene cylinders or composite (fully wrapped or hoop-wrapped) aluminium alloy cylinders.

NOTE — As far as practicable, this standard may also be applied to cylinders of less than 0.5 litre water capacity.

## 2 REFERENCES

The standards given below contain provisions which through reference in this text, constitute provisions of this standard. At the time of publication, the editions indicated were valid. All standards are subject to revision, and parties to agreements based on this standard are encouraged to investigate the possibility of applying the most recent edition of these standards:

<i>IS No.</i>	<i>Title</i>
IS 3224 : 2021	Valve for compressed gas cylinders excluding liquefied petroleum gas (LPG) cylinders — Specification ( <i>fourth revision</i> )
IS 15660 : 2017	Refillable transportable seamless aluminium alloy gas cylinders — Specification ( <i>first revision</i> )

## 3 INTERVALS BETWEEN PERIODIC INSPECTION AND TEST

In order to ensure continued safe operation, cylinders shall be periodically submitted to

inspection and test in accordance with [Table 1](#). A cylinder shall fall due for periodic inspection and test on its first receipt by a filler after the expiry of the interval as per [Table 1](#) or as approved by the statutory authority.

Provided the cylinder has been subjected to normal conditions of use and has not been subjected to abusive and abnormal conditions rendering the cylinder unsafe, there is no general requirement for the user to return a gas cylinder before the contents have been used. Even though the test interval may have lapsed. Once the contents is over cylinders to be sent for periodic inspection.

## 4 LIST OF PROCEDURES FOR PERIODIC INSPECTION AND TEST

The inspection and test shall be carried out only by competent persons who shall ensure that the cylinders are fit for continued safe use.

Each cylinder shall be submitted to periodic inspection and test. The following procedures form the requirements for such inspection and test, and are explained more fully in later clauses:

- a) Identification of cylinder and preparation for inspection and test (*see* [5](#));
- b) External visual inspection (*see* [6](#));
- c) Inspection of cylinder neck/shoulder (*see* [9](#));
- d) Internal visual inspection (*see* [7](#));
- e) Supplementary tests (*see* [8](#));
- f) Pressure test or ultrasonic test (*see* [10](#));
- g) Inspection of valve and other accessories (*see* [11](#));
- h) Final operations (*see* [12](#));
- j) Rejection and rendering cylinders unserviceable (*see* [13](#)); and
- k) Verify for gases not to be contained in aluminium alloy gas cylinders (*see* [14](#)).

It is recommended that the above-listed tests are performed in the suggested sequence. In particular the internal visual examination (*see* [7](#)) should be carried out before the pressure test or ultrasonic test (*see* [10](#)).

To access Indian Standards click on the link below:

[https://www.services.bis.gov.in/php/BIS\\_2.0/bisconnect/knowyourstandards/Indian\\_standards/isdetails/](https://www.services.bis.gov.in/php/BIS_2.0/bisconnect/knowyourstandards/Indian_standards/isdetails/)

Cylinders which fail in the inspection or tests shall be rejected (*see* [13](#)). When, after the above tests, doubts still exist as to the extent of a defect or the condition of a cylinder, then additional tests may be performed in accordance with [8](#), until such doubts are positively resolved, or the cylinder shall be rendered unserviceable.

Some cylinders rejected during periodic inspection and test may be recovered which can be rendered into service in accordance with [Annex B](#).

Mechanical properties of aluminium alloy cylinders

can be affected by heat. Therefore, the maximum temperature for any operation shall be limited (*see* [12.1.2](#)).

The eyesight acuity of operators is critical and should be checked by an optician on a yearly basis.

NOTE — A competent person is a person who has the necessary technical knowledge, experience and authority to assess and approve materials for use with gases and to define any special conditions of use that are necessary. Such a person shall also normally be formally qualified in an appropriate technical discipline.

**Table 1 Intervals for Periodic Inspections and Tests**

(*Clause 3*)

Sl No.	Gas Type	Examples	UN Recommended Period (in years)
(1)	(2)	(3)	(4)
i)	Compressed gases	Ar, N <sub>2</sub> , He, etc	10 <sup>a</sup>
		H <sub>2</sub> <sup>b</sup>	10 <sup>a</sup>
		Air, O <sub>2</sub>	10 <sup>a</sup>
		Self-contained breathing air, O <sub>2</sub> etc	<sup>c</sup>
		Gases for underwater breathing apparatus	<sup>c</sup>
		CO <sup>d</sup>	5 <sup>e</sup>
ii)	Liquefied gases	Refrigerants, CO <sub>2</sub>	10 <sup>a</sup>
iii)	Corrosive gases	<sup>f</sup>	5
iv)	Toxic/very toxic gases that are non-corrosive	Sulfuryl fluoride (SO <sub>2</sub> F <sub>2</sub> ), Arsine (AsH <sub>3</sub> ), Phosphine (PH <sub>3</sub> ), etc	5
v)	Gas mixtures	All mixtures	5 years or 10 years according to dangerous properties.  Generally, toxic or corrosive mixtures have a 5 year interval while other mixtures have a 10 year interval.

NOTES

**1** These test periods may be used provided the dryness of the product and that of the filled cylinder are such that there is no freestanding water. This condition shall be proven and documented within a quality system of the filler. If this condition cannot be fulfilled, alternative or more frequent testing may be appropriate.

**2** At all times, certain requirements can necessitate a shorter time interval, for example, the dew point of the gas, polymerization reactions and decomposition reactions, cylinder design specifications, change of gas service, etc.

**3** In the case of cylinders used for emergency purpose (for example, fire extinguishers, breathing apparatus), it is the responsibility of the person in possession (owner or user) to submitted for a periodic inspection within the interval as specified in Table 1 or specified in the relevant cylinder design standards regulations if this is shorter.

<sup>a</sup> Some transport regulations (for example, ADR) allow the interval between periodic inspections and tests to be extended up to 15 years under specific conditions.

<sup>b</sup> Particular attention shall be paid to the tensile strength and surface condition of such cylinders. Cylinders not in conformance with the special hydrogen requirements shall be withdrawn from hydrogen service.

<sup>c</sup> Local regulations specify the interval of periodic inspection and testing. In the absence of any regulations, an annual internal inspection should be carried out with a periodic inspection carried out every five years. However, if a risk assessment and the specific use of a cylinder indicate that there is a low risk of internal degradation, then the interval for carrying out an internal examination may be increased to a maximum of 2.5 years.

<sup>d</sup> This product requires very dry gas.

<sup>e</sup> The interval between periodic inspections and tests may be extended to 10 years for seamless aluminium alloy cylinders, when the alloy of the cylinder has been subjected to a stress corrosion test as specified in IS 15660.

<sup>f</sup> Corrosiveness is with reference to human tissue and not cylinder material as indicated in [14](#).

## 5 IDENTIFICATION OF CYLINDER AND PREPARATION FOR INSPECTION AND TEST

Before any work is carried out, the relevant cylinder data and its contents and ownership shall be identified and recorded.

The cylinders shall be de-pressurized and emptied in a safe, controlled manner before proceeding. Particular attention shall be given to cylinders containing flammable, oxidizing and toxic gases to eliminate risks at the internal inspection stage.

Cylinders (other than those with a footing) to be ultrasonically inspected may be examined without being depressurized or having the valve removed.

NOTE — The uncontrolled opening and/or removal of valves from cylinders can lead to injury, death and/or property damage.

Cylinders with incorrect markings, unknown gas contents, or those which cannot be safely emptied of gas, shall be set aside for special handling.

Cylinders with in-operative or blocked valves can be treated as outlined in [Annex C](#). Provided the requirements above have been complied with, and the cylinder has been de-pressurized safely, the valve shall be removed. Similarly, in the case of cylinder bundles, not equipped with cylinder valves, the connecting tee junction shall also be checked to determine whether the gas is able to pass freely from the cylinder to atmosphere.

## 6 EXTERNAL VISUAL INSPECTION

### 6.1 Preparation for External Visual Inspection

If a cylinder's external condition prevents or hinders a proper visual inspection of the surface, then the cylinder shall be prepared before the inspection. Each cylinder shall be cleaned and have all loose coatings, corrosion products, tar, oil or other foreign matter removed from its external surface by a suitable method, for example, by brushing, shot blasting (under closely controlled conditions), water jet abrasive cleaning, chemical cleaning (*see* [Annex D](#) or consult the cylinder manufacturer) or other suitable methods.

Alkaline solutions and paint strippers which are harmful to aluminium and its alloys shall not be used. Care shall be taken at all times to avoid damaging the cylinder or removing excess amounts of cylinder wall.

If fused nylon, polyethylene or a similar coating has been applied and is seen to be damaged, or prevents a proper inspection, then the coating shall be removed. If the coating is removed by the

application of heat at a temperature/time exceeding the limits specified in [12.1.2](#) or shows signs of heat damage, the manufacturer shall be consulted before the cylinder is returned to service and the necessary tests and inspections carried out.

### 6.2 Inspection Procedure

The external surface of each cylinder shall then be inspected for:

- a) Dents, cuts, gouges, bulges, cracks, laminations or excessive base wear;
- b) Heat damage, torch or electric arc burns (*see* [Table 5](#));
- c) Corrosion (*see* [Table 6](#));
- d) Other defects such as illegible or unauthorized stamp markings, unauthorized additions or modifications;
- e) Integrity of all permanent attachments; and
- f) Vertical stability (if relevant) (*see* [Table 5](#)).

For rejection criteria, *see* [Annex B](#). Cylinders no longer suitable for future service shall be rendered unserviceable (*see* [13](#)).

## 7 INTERNAL VISUAL INSPECTIONS

### 7.1 Preparation

#### 7.1.1 General

Whenever the internal surface of a cylinder is not adequately visible, a suitable cleaning method shall be applied. The method used to clean the cylinder shall be a validated, controlled process. Care shall be taken at all times to avoid damaging the cylinder taking into account the information provided in [Annex B](#).

#### 7.1.2 Suitable Cleaning Methods for Seamless Aluminium-Alloy Cylinders

If necessary, suitable cleaning methods such as water jet abrasive cleaning, flailing, steam jet, hot water jet, chemical cleaning, blasting with glass beads or others may be used on seamless aluminium-alloy cylinders (*see* [Annex D](#) or consult the cylinder manufacturer). Cleaning with material other than alumina or glass beads, etc shall be avoided. Hard media can embed itself in the aluminium alloy. Alkaline solutions and paint strippers that are harmful to aluminium and its alloys shall not be used.

If the cylinder has been cleaned by one of the above methods, it shall be dried immediately after being cleaned and inspected.

Ensure that any aqueous liquid does not stay in the cylinder for more than two hours.

## 7.2 Inspection Requirements

Internal visual inspections shall be conducted in good lighting on a cylinder that is both clean and dry, suitable enough for proper inspection of all surfaces to identify any imperfections similar to those listed in [6.2\(a\)](#) and [6.2\(c\)](#). These inspections may be augmented by the use of a boroscope, dental mirror or another suitable device. When magnification is used, the final assessment of the imperfection shall be carried out as if no magnification had been used.

When needed, the severity of a detected imperfection may be further evaluated by using other devices or methods.

Precautions shall be taken to ensure that the method of illumination presents no risks to the tester while performing the operation (for example, use of a filament lamp in a potentially explosive environment shall be avoided).

Any cylinder showing presence of foreign matter or signs of more than light surface corrosion shall be cleaned internally (*see* [7.1](#)), under closely controlled conditions by shot blasting, water jet abrasive cleaning, flailing, steam jet, hot water jet, rumbling, chemical cleaning (*see* [Annex D](#) or consult cylinder manufacturer), or other suitable method. Care shall be taken to avoid damage to the cylinder. If cleaning is required, the cylinder shall be re-inspected after the cleaning operation.

Alternative methods may be substituted for the internal visual inspection for cylinders that contain non-corrosive gases that have a water capacity less than 0.5 litre and an internal neck diameter less than 9 mm. These alternative methods include:

- a) Looking for free moisture at the time of depressurizing after the cylinder has been in an inverted position for at least 1 min and prior to valve removal; and
- b) Looking for contamination (for example, rust in the test medium following the hydraulic volumetric expansion test).

If any moisture is present upon inversion of the cylinder or if rust contamination is observed in the hydraulic volumetric expansion test medium, the cylinder shall be either re-examined after cleaning in accordance with [7.1.1](#) or rendered unserviceable in accordance with [13](#).

## 7.3 Cylinders with Footrings

Special attention shall be given to inspect cylinders with footrings for defects in critical areas, that is, the

transition (footring) zone and the cylinder base.

## 7.4 Cylinders with Internal Coatings

Cylinders used in certain applications (for example, corrosive gases) can have an internal coating such as an electrochemical deposit, cladding, paint or a film to inhibit corrosion.

Since the hydraulic volumetric expansion test medium can affect the coating, the manufacturer shall be contacted in case of doubt to determine the correct type of testing to be used.

Care shall be taken when a coating might contain flammable components, for example, hydrocarbons in paint or a corrosion inhibitor.

A damaged coating shall be removed to allow for a complete visual inspection. When the damaged coating (for example, cladding) cannot be removed, the manufacturer shall be consulted for guidance on how to prepare the cylinder for periodic inspection and testing.

If the manufacturer cannot be consulted, the cylinder shall be rendered unserviceable in accordance with [13](#).

Certain hydrogen production processes can involve contamination of the gas by mercury. Any aluminium alloy cylinder internally contaminated with mercury shall be rendered unserviceable.

## 8 SUPPLEMENTARY TESTS

Where there is doubt concerning the type and/or severity of a defect found on visual inspection (*see* [6](#) and [7](#)), additional tests or methods of examination may be applied, for example, ultrasonic techniques, check weighing or other non-destructive tests. Only when all doubts are eliminated may the cylinder be further processed (*see* [Annex B](#)).

If a hardness test is required it shall only be according to relevant Indian Standard or a suitable alternative method for example, conductivity. The result shall meet, at least, the minimum required design hardness value. An alternative method may only be used, if it was employed at the time of cylinder manufacture and recorded accordingly on the test certificate. When the minimum design hardness value is not known, the cylinder shall be hardness tested both before and after any stoving operation and there shall be no appreciable decrease in the hardness value, as agreeable to the competent person. All hardness tests shall be performed on the parallel section of the cylinder, taking adequate care to ensure that deep impressions are not formed.

## 9 INSPECTION OF CYLINDER NECK/ SHOULDER

### 9.1 Internal Neck Thread

The internal neck thread of the cylinder shall be examined to ensure that it is:

- a) Clean and of full form;
- b) Free of damage;
- c) Free of burrs;
- d) Free of cracks — Examine thoroughly for evidence of cracks (see [Annex B](#)); and
- e) Free of other imperfections.

Cracks manifest themselves as lines which run vertically down the thread and across the thread faces. They should not be confused with tap marks (thread machining marks). Special attention should be paid to the area at the bottom of the thread.

### 9.2 Other Neck and Shoulder Surfaces

Other surfaces of the neck and shoulder shall also be examined to ensure that they are free of cracks or other defects (see [Annex B](#)).

### 9.3 Damaged Internal Neck Threads

Where necessary, and where the manufacturer or the competent person confirms that the design of the neck permits, threads may be re-tapped only by competent persons to provide the appropriate number of effective threads. After re-tapping, the threads shall be checked by the appropriate thread gauge.

### 9.4 Neck Ring and Collar Attachment

When a neck ring/collar is attached, an examination to ensure that it is secure and free from thread damage shall be carried out. Neck rings shall only be changed using an approved procedure. If it is found that any significant damage to cylinder material has occurred by replacement of the neck ring/collar, the cylinder shall be rendered unserviceable. If the neck ring has been re-attached by welding or brazing, the cylinder shall be rendered unserviceable.

## 10 PRESSURE TEST OR ULTRASONIC TEST

### 10.1 General

Each cylinder shall be subjected to a hydraulic or pneumatic pressure test (see [10.2](#)) or may be replaced by a pneumatic proof pressure test. Alternatively, ultrasonic examination may be considered subject to approval of statutory authority (see [10.3](#)).

Appropriate measures shall be taken to ensure safe

operation and to contain any energy that might be released. It should be noted that pneumatic proof pressure tests require more precautions than hydraulic volumetric expansion tests, regardless of the size of the cylinder or tube. Any error in carrying out this test is highly likely to lead to a rupture under gas pressure. Therefore, these tests shall be carried out only after ensuring that the safety measures adopted satisfy the safety requirements.

Special care shall be taken using air as the medium for the pneumatic pressure test due to the oxidizing potential of high pressure air. At 300 bar, the partial pressure of oxygen is approximately 60 bar.

When air is used for the pneumatic pressure test, the cylinder shall not have internal flammable materials (for example, coatings containing hydrocarbons). Special care shall be taken during the periodic inspection and testing of cylinders that have been used in flammable gas service.

### 10.2 Pressure Test

#### 10.2.1 General Requirements

When carrying out a pressure test, a suitable fluid, normally water shall be used as the test medium. The test may be a proof pressure test (see [10.2.2](#)) or a volumetric expansion test (see [10.2.3](#)), as appropriate to the design of the cylinder. Having decided to use one particular type of test, its result shall be final. No attempt shall be made to transfer from one type of test to the other. The test pressure shall be in accordance with the stamping on the cylinder.

The pressure in the cylinder shall be increased gradually until the test pressure is reached. The cylinder test pressure shall be held for at least 30 s with the cylinder isolated from the pressure source, during which time there shall be no decrease in the recorded pressure or any evidence of any leakage. Safety precautions shall be taken during the test.

For seamless aluminium alloys cylinders it shall be ensured that any aqueous liquid does not stay in the cylinder for more than 2 h.

#### 10.2.2 Proof Pressure Test

During the 30 s hold period the pressure as registered on the test gauge shall remain constant.

There shall be no visible leakage or visible permanent deformation on the entire surface of the cylinder. This check may be made either during the 30 s hold or immediately after the pressure has been released (see [Annex E](#)).

Any cylinder failing conforming to with the

requirements of this test shall be rendered unserviceable.

NOTE — A pneumatic pressure test may be substituted, provided approval from the relevant authority has been obtained. Take appropriate measures to ensure safe operation and to contain any energy, which is considerably more than that in the hydraulic test, which can be released.

### 10.2.3 Volumetric Expansion Test

[Annex F](#) specifies a typical method for carrying out the test and gives details for determining the volumetric expansion of seamless aluminium alloy gas cylinders by the preferred water jacket method or the non-water jacket method (*see* [Annex F](#)).

The permanent volumetric expansion of the cylinder expressed as a percentage of the total expansion at test pressure shall not exceed the percentage given in the design specification after the cylinder has been held at test pressure for a minimum period of 30 s. If this figure for permanent expansion is exceeded the cylinder shall be rendered unserviceable (*see* IS 15660).

### 10.3 Ultrasonic Test

Ultrasonic testing may be considered in place of the pressure test subject to approval of statutory authority. Ultrasonic testing, if carried out, shall be in accordance with the method specified in [Annex G](#).

## 11 INSPECTION OF VALVE AND OTHER ACCESSORIES

If it is to be re-introduced into service, each valve (or tee junction for bundles) shall be inspected to verify that it will perform satisfactorily and ensure gas tightness. An example of a suitable method is given in [Annex H](#).

## 12 FINAL OPERATIONS

### 12.1 Drying, Cleaning and Painting

#### 12.1.1 Drying and Cleaning

The interior of each cylinder shall be thoroughly dried (*see* [12.1.2](#) for maximum temperature/time values to be used) by a suitable method, immediately after hydraulic pressure testing, such that there is no trace of free water. The interior of the cylinder shall be inspected to ensure that it is dry and free from other contaminants.

#### 12.1.2 Painting

Cylinders are sometimes re-painted, using paints which require stoving. Plastics coatings may only be re-applied in consultation with the cylinder manufacturer. Painting or coating shall be applied

such that all markings stamped on the cylinder are legible.

Aluminium alloy cylinders are normally manufactured using precise heat treatment to obtain the final mechanical properties. Therefore, the maximum temperature for any operation shall be limited.

In no case the temperature of the cylinder shall exceed that recommended by the manufacturer since overheating changes the mechanical properties of the cylinder. When the cylinder's alloy/heat treatment cannot be established the following requirements for non-heat treated alloy apply.

Cylinders manufactured from AA 6XXX heat-treatable aluminium alloys (for example, AA 6061) shall not be heated to temperatures exceeding 175 °C. Only testing facilities that can control heat input and record time and temperature shall heat cylinders. The total cumulative time at temperatures between 110 °C and 175 °C shall be limited to the time recommended by the cylinder manufacturer. Cylinders heated in accordance with these provisions shall not require further testing (*see* [8](#)).

An external heat source shall not be applied (for example, to dry an external coating) to AA 7XXX heat-treatable (for example, AA 7032 or AA 7060) seamless aluminium-alloy cylinders and tubes unless approved by the cylinder or tube manufacturer.

Unless otherwise authorized by the cylinder manufacturer, the maximum temperature shall not exceed 80 °C for seamless aluminium-alloy cylinders manufactured from non-heat treated alloys (for example, AA 5283). The exposure time shall be limited to 30 min for temperatures between 70 °C and 80 °C. If the heat exposure time exceeds 30 min at temperatures greater than or equal to 70 °C, or if at any time the temperature exceeds 80 °C, then agreement shall be obtained from the manufacturer regarding the further use of the cylinder (*see* [8](#)).

The color identification of the requalified cylinder shall be as per IS 15660.

### 12.2 Re-valving of the Cylinder

The appropriate valve shall be fitted to the cylinder using a sealing material. An optimum torque necessary to ensure both a seal between the valve and the cylinder and prevent over-stressing the neck shall be used.

The torque applied shall take into consideration the size and form of the threads, the material of the valve, and the type of sealing material used



according to the manufacturer's recommendations. Where the use of lubricants/sealing material is permitted, only those approved for the gas service shall be used, taking particular care for oxygen service.

### 12.2.1 Torque Values for Taper and Parallel Threads

The external diameter and thickness of the formed neck end of the cylinder shall be adequate for the torque applied in fitting the valve to the cylinder. The torque may vary according to the diameter of thread, the form, and the sealant used in fitting of the valve. The cylinder shall have threads as per IS 3224 or any other threads specification approved by statutory authority. Threads shall be in full form, clean cut, even and without check, machined into gauge and concentric with axis of cylinder. Valving torque for aluminium alloy cylinders shall conform to [Table 2](#) and [Table 3](#).

### 12.3 Check on Cylinder Tare

This requirement shall only apply to cylinders for liquefied gases. The tare of the cylinders shall be obtained by weighing on a machine regularly checked for accuracy. The capacity of the weighing machine shall be suitable for the tare weight of the cylinders.

The tare shall include the mass of the cylinder, valve(s) and all permanent fittings. If the tare of the cylinder differs from the stamped tare by more than the value shown in [Table 4](#) and is not due to reasons of damage, the original tare shall be cancelled and the correct tare shall be marked in a permanent and legible fashion.

### 12.4 Reference to Next Test Date

The next test date shall be shown in a clearly visible manner by an appropriate method such as a label or a disc fitted between the valve and the cylinder, indicating the year of the next periodic inspection or periodic inspection and test.

### 12.5 Identification of Contents

Before the cylinder is re-introduced into service, the cylinder shall be marked according to the intended contents. If painting is required, care shall be exercised in accordance with [12.1.2](#). If a change of gas service is involved, care shall be taken to follow the requirement of relevant Indian Standards and statutory requirement.

### 12.6 Records

Details of the present test shall be recorded by the

test station and the following information shall be available:

- a) Owner's name;
- b) Manufacturer's or owner's serial number;
- c) Cylinder tare, where applicable;
- d) Test pressure;
- e) Present test date;
- f) Identification symbol of the inspection body or the test station;
- g) Identification of inspector; and
- h) Details of any modifications made to the cylinder by the inspector.

Additionally, it shall be possible to obtain the following items of information from records, which need not necessarily be kept on a single file but shall enable a particular cylinder to be traced. These items are:

- a) Cylinder manufacturer;
- b) Manufacturer's serial number;
- c) Manufacturing specification;
- d) Type of inspection and test performed;
- e) Water capacity/size;
- f) Manufacturing test date; and
- g) Result of test (pass or fail).

In case of failure, the reason(s) should be recorded.

Records shall be retained by the retester for at least 15 years or until the next periodic inspection date. For identifying the next inspection date (see [Annex J](#)).

## 13 REJECTION AND RENDERING CYLINDER UNSERVICEABLE

The decision to reject a cylinder may be taken at any stage during the inspection and test procedure. If it is not possible to recover a rejected cylinder, it shall, after notifying the owner, be made unserviceable by the testing station for holding gas under pressure so that it is impossible for any part of the cylinder, especially the shoulder, to be re-issued into service.

In case of any disagreement, ensure that the legal implication of the contemplated action is fully understood.

One or a combination of the following methods can be employed to render the cylinder unserviceable, after ensuring that the cylinder is empty and free of gas (see [6](#)).

- a) Crush the cylinder, preferably in the shoulder area, using mechanical means;
- b) Burn an irregular hole in the top dome equivalent in area to approximately 10 percent of the area of the top dome or, in the case of a thin-walled cylinder pierce in at least three places;
- c) Cut the neck in an irregular fashion;
- d) Cut the cylinder including the shoulder into two or more irregular pieces; and
- e) Burst in a safe manner.

**Table 2 Torque Values for Taper Threads**

(Clause 12.2.1)

SI No.	Taper Valve Stem Size	Torque		
		Minimum (N.m)	Maximum (N.m)	
			Without Cylinder Neck Reinforcement	With Cylinder Neck Reinforcement
(1)	(2)	(3)	(4)	(5)
i)	17E	75	95	140
ii)	25E	95	110	180

NOTE — All parallel threads must have at least 6 engaged threads, tight fit, and a factor of safety in shear of at least 10 at the test pressure of the cylinder. The threads must extend completely through the neck.

**Table 3 Torque Values for Parallel Threads**

(Clause 12.2.1)

SI No.	Parallel Valve Stem Size	Torque	
		Minimum (N.m)	Maximum (N.m)
(1)	(2)	(3)	(4)
i)	M18	85	100
ii)	M25	95	130
iii)	M30	95	130
iv)	0.75-16-UNF-2B	85	100
v)	1.125-12-UNF-2B	95	130

**Table 4 Maximum Allowable Deviation in Cylinder Tare Weight**

(Clause 12.3)

SI No.	Cylinder Water Capacity (V) litre	Maximum allowable Deviation in Tare Weight
(1)	(2)	(3)
i)	$0.5 \leq V \leq 1.0$	$\pm 25$
ii)	$1.0 < V < 5.0$	$\pm 50$
iii)	$5.0 < V < 20$	$\pm 200$
iv)	$V > 20$	$\pm 400$

#### 14 GASES NOT TO BE CONTAINED IN ALUMINIUM ALLOY CYLINDERS

Subject to the exceptions stated, the following gases shall not be contained in aluminium alloy cylinders. Certain of these gases may however be contained in aluminium alloy cylinders in small quantities as components of gas mixtures. Approval for such use shall be sought from the competent authority.

- a) Acetylene;
- b) Boron trifluoride;
- c) Bromo trifluoroethylene;
- d) Chlorine trifluoride;

- e) Cyanogen chloride;
- f) Fluorine;
- g) Hydrogen bromide;
- h) Hydrogen chloride;
- j) Hydrogen fluoride;
- k) Methyl bromide;
- m) Methyl chloride; and
- n) Nitrosyl chloride.

NOTE — A special warning to filling stations while filling oxygen in aluminium-alloy cylinders is that since aluminium is a good conductor of heat and prone to get heated very fast, the oxygen to be filled by controlling the amount of flow of oxygen, so as to avoid the cylinders get heated.

**Table 5 Rejection Limits Relating to Physical and Material Defects in the Cylinder Shell**

(Clauses [6.2](#), [B-2](#), [B-3.2](#), [B-4.1](#), [F-4.6](#) and [G-2.1](#))

SI No.	Type of Defect	Definition	Rejection Criteria in Accordance with (Clause <a href="#">6</a> <sup>1</sup> )	Repair or Render Unserviceable
(1)	(2)	(3)	(4)	(5)
i)	Tap marks	Thread machining marks typically appearing as straight lines (not to be confused with neck cracks)	Acceptable	No repair necessary
ii)	Plug or neck inserts	Additional inserts fitted in the cylinder neck, base or wall	All cylinders unless it can be clearly established that addition is part of approved design	Repair possible
iii)	Stamping	Marking by means of a metal Punch	All cylinders with illegible, modified or incorrect markings	Render unserviceable <sup>6</sup>
iv)	Arc or torch burns	Partial melting of the cylinder, addition of weld metal or removal of metal by scarfing or cratering	All cylinders with such defects	Render unserviceable
v)	Suspicious marks	Marks introduced other than by the cylinder manufacturing process and approved repair	All cylinders with such defects	Continued use possible after additional inspection to eliminate doubt for continued service
vi)	Vertical stability	-	Deviation from verticality that can present a risk during service (especially if fitted with footing)	Repair or render unserviceable
vii)	Bulge	Visible swelling of the cylinder	All cylinders with such a defect	Render unserviceable

Table 5 (Continued)

Sl No.	Type of Defect	Definition	Rejection Criteria in Accordance with (Clause 6 <sup>1</sup> )	Repair or Render Unserviceable
(1)	(2)	(3)	(4)	(5)
viii)	Dent	A depression in the cylinder that has neither penetrated nor removed metal and is greater in depth than 1 percent of the external diameter	When the depth of the dent exceeds 3 percent of the external diameter of the cylinder or When the diameter of the dent is less than $\times 15$ its depth	Render unserviceable  Render unserviceable
ix)	Cut or Gouge	A sharp impression where metal has been removed, displaced or redistributed and whose depth exceeds 5 percent of the cylinder's minimum design wall thickness (see Fig. 1)	When the depth of the cut or gouge exceeds 10 percent of the minimum design wall thickness or When the length exceeds 25 percent of the external diameter of the cylinder	Repair possible <sup>2</sup>  Repair possible <sup>2, 3</sup>
x)	Crack	A split or separation in the metal typically appearing as a line on the surface (see Fig. 2)	All cylinders with such defects	Render unserviceable
xi)	Fire/excessive heat damage	Excessive general or localized heating of a cylinder usually indicated by: a) Partial melting of the cylinder; b) Distortion of cylinder; c) Charring or burning of paint; and d) Fire damage to valve, melting of plastic guard, date ring or fusible plug if fitted.	All cylinders in categories (a) and (b)  Cylinders in categories (c) and (d) may be acceptable after inspection and testing	Render unserviceable  Repair possible. In case of doubt, render unserviceable.
xii)	Lamination	Layering of the material with a surface breaking imperfection sometimes appearing as a discontinuity, crack, lap or bulge at the surface	All cylinders with such defects	Render unserviceable for internal defects  Repair possible for external defects <sup>2</sup>
xiii)	Neck cracks	A split or separation in the material typically appearing as lines usually running down/up the thread vertically and across the thread (not to be confused with tap marks) <sup>4, 5</sup>	Cylinders with such defects	Render unserviceable

<sup>1</sup> When applying the rejection criteria given in this table, the conditions of use of the cylinders, the severity of the defect and safety factors in the design shall be taken into consideration.

<sup>2</sup> Repair is possible provided that, after repair by a suitable metal removal technique, the remaining wall thickness is at least equal to the minimum design wall thickness.

<sup>3</sup> If the measured wall thickness is less than the minimum design wall thickness, the cylinder shall either be rendered unserviceable.

<sup>4</sup> Unlike tap marks, cracks can appear on the top face of the cylinder neck.

<sup>5</sup> The following applies only to seamless aluminium-alloy cylinders, some neck cracks (< 1 mm in depth) may be repaired only in accordance with an agreed manufacturer's specification.

<sup>6</sup> If it can be clearly established that the cylinder fully complies with the appropriate specification, altered operational and modified markings may be acceptable and inadequate markings may be corrected, provided there is no possibility of confusion.

Table 6 Rejection Criteria for Corrosion of the Cylinder Wall

(Clause 6.2)

Sl No.	Type of Corrosion	Definition	Rejection Criteria in Accordance with (Clause 6 <sup>1</sup> )	Repair or Render Unserviceable
(1)	(2)	(3)	(4)	(5)
i)	General corrosion	Loss of wall thickness over an area of more than 20 percent of either the interior or the exterior total surface area of the cylinder (see Fig. 5)	If the original surface of the metal is no longer recognizable	Repair possible <sup>2,3</sup>
			or	
			If the depth of penetration exceeds 10 percent of the minimum design wall thickness and the remaining wall thickness is equal to or greater than the minimum design wall thickness	Repair possible <sup>2,3</sup>
ii)	Local corrosion	Loss of wall thickness over an area of less than 20 percent of either the interior or the exterior total surface area of the cylinder, except for the other types of local corrosion described below	or	
			If the measured wall thickness is less than the minimum design wall thickness	Render unserviceable
iii)	Chain pitting or line corrosion	Corrosion forming a narrow longitudinal or circumferential line or strip, or isolated craters or pits that are almost connected (see Fig. 6)	If the depth of penetration exceeds 20 percent of the minimum design wall thickness and the remaining wall thickness is equal to or greater than the minimum design wall thickness	Repair possible <sup>2</sup>
			or	
iv)	Isolated pits	Corrosion forming isolated craters, without significant alignment (see Fig. 7).	If the measured wall thickness is less than the minimum design wall thickness	Render unserviceable
			If the total length of corrosion in any direction exceeds the diameter of the cylinder and the depth exceeds 10 percent of the minimum design wall thickness	Repair possible <sup>2,3</sup>
			or	
			If the wall thickness is less than the minimum design wall thickness	Render unserviceable
			If the diameter of the pits is greater than 5 mm, refer to the 'local corrosion' row.	Repair possible <sup>2,3</sup>

Table 5 (Concluded)

Sl No.	Type of Corrosion	Definition	Rejection Criteria in Accordance with (Clause 6 <sup>1</sup> )	Repair or Render Unserviceable
			<p>If the diameter of the pits is less than 5 mm, the cylinders should be assessed as carefully as possible in order to check that the remaining thickness of the wall or base is adequate for the intended use of the cylinder.</p> <p>or</p> <p>If the wall thickness is less than the minimum design wall thickness</p>	
v)	Crevice corrosion	Corrosion associated with taking place in, or immediately around, an aperture	If, after thorough cleaning, the depth of penetration exceeds 20 percent of the minimum design wall thickness	<p>Render unserviceable</p> <p>Repair possible<sup>3</sup></p>



FIG. 1 CUT OR GOUGE



FIG. 2 CRACK



FIG. 3 FIRE DAMAGE



FIG. 4 ARC OR TORCH BURNS

<sup>1</sup> If the bottom of the defect cannot be seen and if its extent cannot be determined using appropriate equipment, the cylinder shall be rendered unserviceable in accordance with 13.

<sup>2</sup> After repair, a cylinder shall meet the requirements given in 6, 7 and 9.

<sup>3</sup> Repair is possible provided that, after repair by a suitable metal removal technique, the remaining wall thickness is not less than minimum wall thickness of the cylinder.

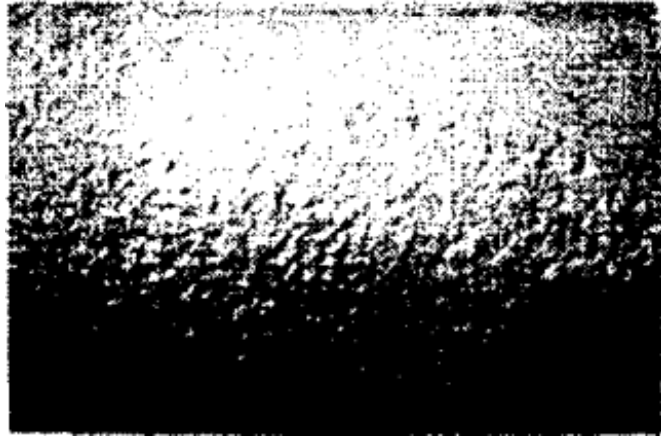

FIG. 5 GENERAL Corrosion

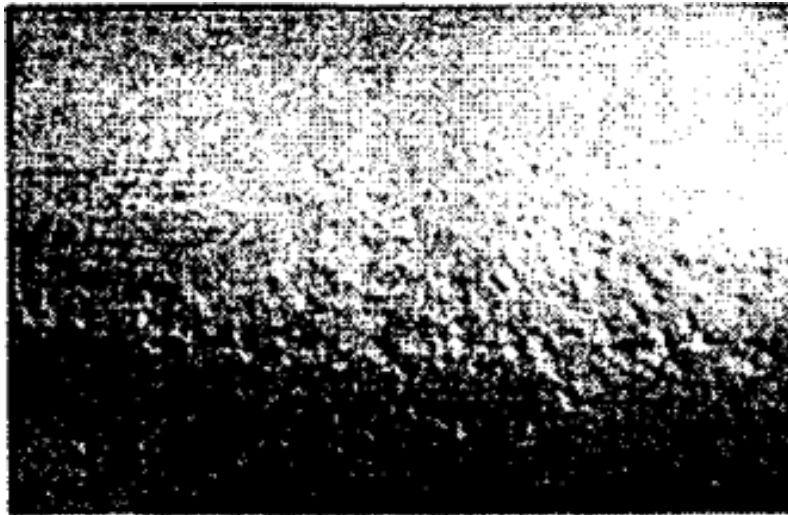

FIG. 6 LINE CORROSION



FIG. 7 ISOLATED PITS

## ANNEX A

(Foreword)

## GAS CYLINDERS MANUFACTURED ACCORDING TO NATIONAL REGULATIONS

**A-1 GENERAL**

This annex specifies those checks, inspections and tests, which shall be performed in order to qualify existing gas cylinders, manufactured according to IS 15660.

**A-2 GENERAL REQUIREMENTS**

**A-2.1** The owner of the gas cylinders shall indicate to the inspection body the types and the number of gas cylinders presented for qualification.

For each of the cylinders the following information shall be made available for documentation and subsequent calculation.

- a) Serial number;
- b) Identification of manufacturer;
- c) Month and year of hydrostatic test;
- d) Number of this standard and aluminium alloy type/designation;
- e) Test pressure, in kgf/cm<sup>2</sup>;
- f) Tare weight, in kg, and nominal water capacity, in litres; and
- g) Inspectors official mark.

Filling pressure at 15 °C in case of permanent gases, in bar or kgf/cm<sup>2</sup>, and filling ratio, in case of liquefiable gases, name of chemical symbol of the gas for which cylinder is to be used and inspection body shall verify that this list contains all the necessary information to clearly define the cylinder (*see* example of production testing certificate in the [Annex G](#) of IS 15660 for the above listed parameters only).

**A-2.2** The inspection body shall verify that these cylinders are not on any relevant national safety related recall list. Additionally, if any restrictions of use apply they shall be maintained for further use.

**A-2.3** The owner shall provide information to enable the inspection body to verify that these cylinders are not or have not been in service with gases corrosive to aluminium alloy as specified in [14](#). The inspection body shall verify that the wall thickness of the gas cylinders is equal to, or greater than, the minimum wall thickness, as calculated in accordance with IS 15660 for the corresponding yield stress of the cylinder.

**A-2.4** The inspection body shall verify that the manufacturing certificates or equivalent records are available. When manufacturing certificates are not available, the inspection body shall verify that all relevant type testing and manufacturing batch testing have been performed.

**A-2.5** The inspection body shall perform the periodic inspection according to this standard.

**A-3 SPECIFIC REQUIREMENTS**

If any of the general requirements in [A-2.1](#) to [A-2.5](#) are not fully met, the cylinder may be qualified, if the inspection body is able to verify the following, as appropriate:

- a) Inspection body shall verify the calculation of the minimum wall and base thicknesses;
- b) All cylinders shall be ultrasonically tested according to the method indicated in [Annex G](#) as appropriate to verify that the minimum wall and base thicknesses of each cylinder are equal to or greater than the minimum wall and base thicknesses prescribed by IS 15660 and that the cylinders are free from harmful defects, as described in [Annex B](#);
- c) A hardness test shall be performed on each cylinder as described in IS 15660. The results shall be compared to the requirements in the original specification, if available. Any significant deviation shall be indicated and explained;
- d) For aluminium alloy cylinders the corrosion test certificates (intercrystalline and stress corrosion) in accordance with IS 15660 shall be presented; and
- e) Cylinder shall be hydraulically tested in accordance with [10.1](#) or [10.2](#).

**A-4 SPECIAL MARKINGS****A-4.1 General**

After satisfactory completion of the periodic inspection and tests, each cylinder shall be permanently marked according to following relevant standard or regulation:

- a) Present test date, followed by; and



- b) The symbol of the inspection body or test station.

#### **A-4.2 Re-test Date and Re-tester Symbol**

The re-test date of the present test, which shall be indicated by the year and month. The re-tester symbol is the symbol of the inspection body or test station.

#### **A-4.3 Reference to Next Test Date**

In accordance with the relevant regulations of an

authorized body and when regulations require, the next test date may be shown by an appropriate method such as by a disc fitted between the valve and the cylinder indicating the date (year and month) of the next periodic inspection and/or tests.

#### **A-5 INSPECTION REPORT**

The inspection body shall prepare a report for each type of cylinder.

All relevant certificates, new tests and inspections performed shall be attached to this report.

### **ANNEX B**

(Clauses [4](#), [6.2](#), [7.1.1](#), [8](#), [9.1](#), [9.2](#), [A-3](#), [G-5](#) and [G-6](#))

#### **DESCRIPTION, EVALUATION OF DEFECTS AND CONDITIONS FOR REJECTION OF SEAMLESS ALUMINIUM ALLOY GAS CYLINDERS AT TIME OF VISUAL INSPECTION**

##### **B-1 GENERAL**

Gas cylinder defects can be physical or material or due to corrosion as a result of environmental or service conditions to which the cylinder has been subjected during its life. The object of this annex is to give general guidelines to the gas cylinder users as to the application of rejection criteria. This Annex applies to all cylinders but those which have contained gases having special characteristics may require modified controls. Any defect in the form of a sharp notch may be removed by grinding, machining or other approved methods. After such a repair, checking of the wall thickness, for example, ultrasonically, shall be repeated.

##### **B-2 PHYSICAL OR MATERIAL DEFECTS**

Evaluation of physical or material defects shall be in accordance with of [Table 5](#).

##### **B-3 CORROSION**

###### **B-3.1 General**

The cylinder can be subjected to environmental conditions that could cause external corrosion of the metal.

Internal corrosion of the metal can also occur owing to service conditions.

There is difficulty in presenting definite rejection limits in tabular form for all sizes and types of cylinders and their service conditions. The limits of rejection have been established following considerable field experience.

Extensive experience and judgement are required in evaluating whether cylinders that have corroded internally are safe and suitable for return to service. It is important that the surface of the metal is cleaned of corrosion products prior to the inspection of the cylinder.

###### **B-3.2 Types of Corrosion**

The types of corrosion possible are classified as described in [Table 5](#).

##### **B-4 NECK AND SHOULDER CRACKS**

###### **B-4.1 Cylinder Rejection**

Reject cylinders exhibiting cracks in accordance with [Table 5](#).

###### **B-4.2 Neck Cracks**

Some cylinders with taper threads can be subject to neck cracks. After cleaning in a suitable way, cracks can be detected by visual inspection. [Fig. 8](#) shows the location and likely propagation of such cracks. Neck cracks shall not be confused with tap markings, which normally are visible parallel lines. [Fig. 9](#) shows tap markings.

###### **B-4.3 Shoulder Cracks**

Some cylinders with parallel threads can be subject to shoulder cracks. They start from folds in the internal shoulder area and propagate into the threaded area or shoulder area of the cylinder. Hence, this lower threaded area of the neck shall be very carefully inspected. [Fig. 10](#) shows where shoulder cracks start and how they propagate.

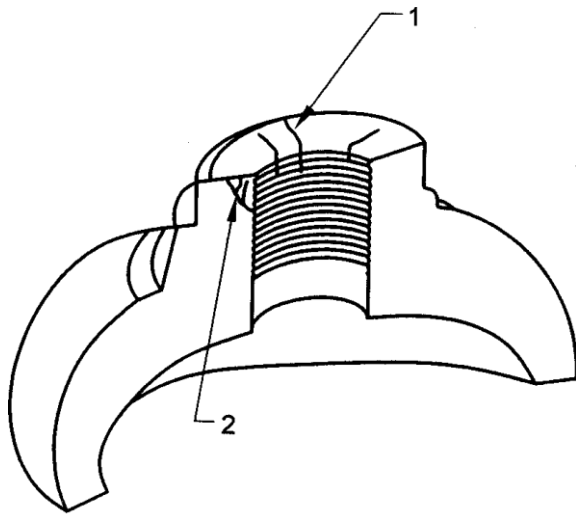

Key

- 1 Neck cracks
- 2 Propagated crack in the neck

FIG. 8 NECK CRACKS

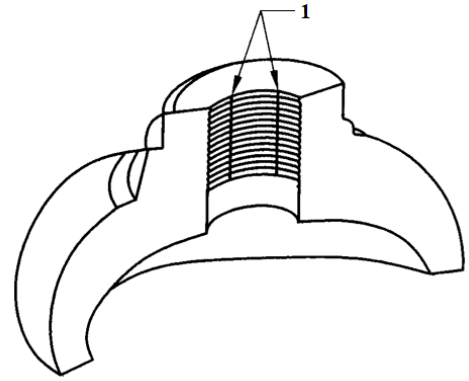

Key

- 1 Tap marks

FIG. 9 TAP MARKS

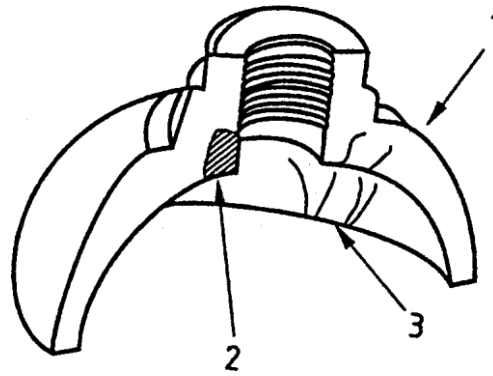

Key

- 1 Shoulder cracks
- 2 Propagated cracks in the shoulder
- 3 Folds

FIG. 10 SHOULDER CRACKS

## ANNEX C

(Clause 5)

**PROCEDURE TO BE ADOPTED WHEN A CYLINDER VALVE IS SUSPECTED TO BE OBSTRUCTED**

**C-1** If there is any doubt when the valve of a gas cylinder is opened, that gas is not being released and the cylinder may still contain residual gas under pressure, a check shall be made to establish that the free passage through the valve is not obstructed.

The method adopted shall be a recognized procedure such as one of the following or one that provides equivalent safeguards.

- For cylinders of liquefied gases, first check to establish that the weight of the cylinder is the same as the tare weight stamped on the cylinder. If there is a positive difference, the cylinder may contain either liquefied gas under pressure or contaminants;
- Introduce inert gas at a pressure of up to 5 bar and check its discharge; and
- Use the device shown in [Fig. 11](#) to pump air into the cylinder, by hand.

**C-2** When it is established that there is no obstruction to gas flow in the cylinder valve, the valve may be removed.

**C-3** When a cylinder is found to have an obstructed gas passage in the valve, the cylinder shall be set

aside for special attention as follows.

- Saw or drill the valve body until interception is made with the gas passage between the valve body stem and valve spindle seat. Cooling shall be provided, especially, if toxic gases are involved; or
- Loosen or pierce the safety device in a controlled manner.

These methods are applicable to cylinders of non-toxic, non-flammable, non-oxidizing, and non-CFC gases. Appropriate safety precautions shall be taken to ensure that no hazard results from the uncontrolled discharge of any residual gas.

Where the contents are toxic, flammable, oxidizing or CFC, the preferred method is to unscrew partially the valve within a glanded cap, secured and joined to the cylinder and vented to a safe discharge. The principles of a suitable device are illustrated in [Fig. 12](#).

These procedures shall be carried out only by trained personnel. When the gas, if any, has been released and the pressure within the cylinder reduced to atmospheric pressure, and, in the case of liquefied gases, when there is no frost or dew on the outside of the cylinder, the valve may be removed.

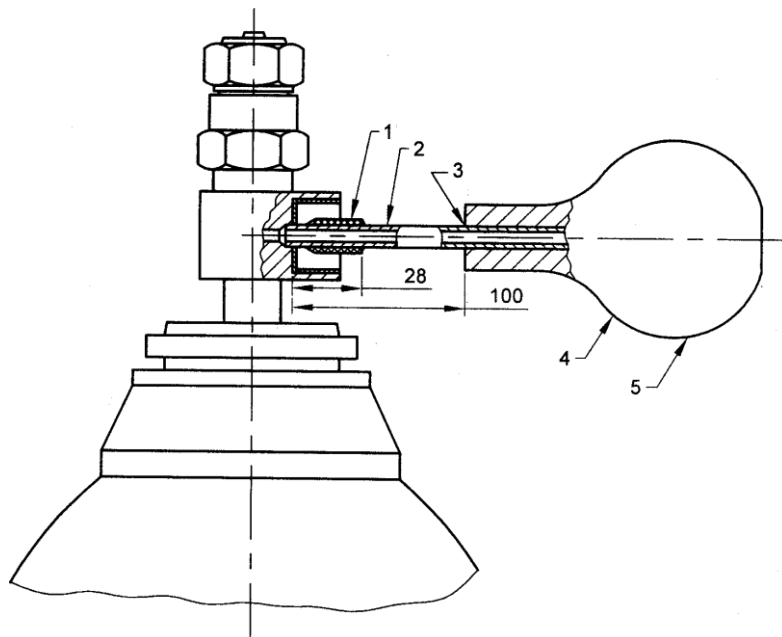

Key

- 1 Rubber tube (internal diameter 8 mm, external diameter 13 mm) ground to olive shape and bonded
- 2 Copper tube (internal diameter 3 mm, external diameter 8 mm)
- 3 Bond
- 4 Rubber bulb
- 5 Hand pressure

All dimensions in millimetres.

FIG. 11 DEVICE FOR DETECTING OBSTRUCTED CYLINDER VALVE

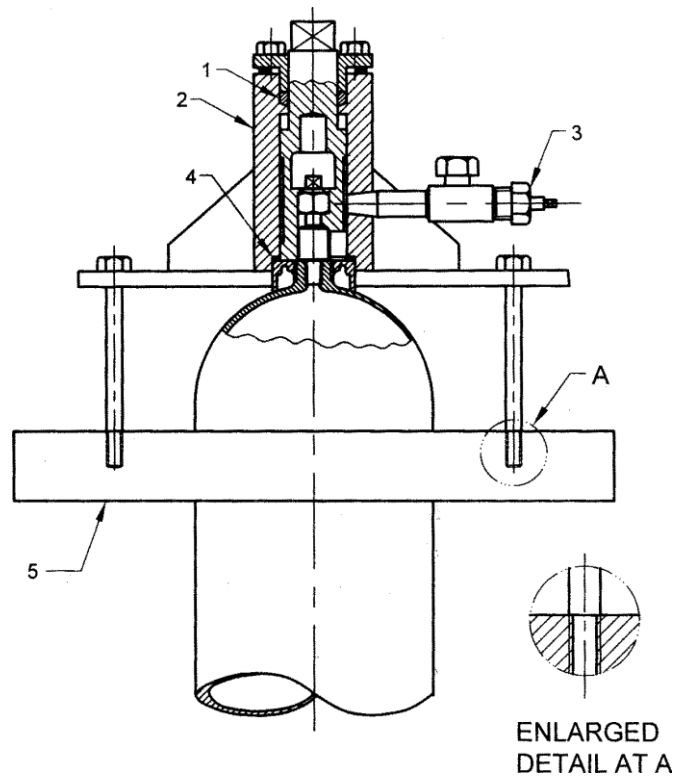

Key

- 1 Rubber gland packing
- 2 Extractor casing
- 3 Control valve
- 4 Joint ring
- 5 Clamp

FIG. 12 TYPICAL DEVICE FOR THE REMOVAL OF A DAMAGED GAS CYLINDER VALVE

## ANNEX D

(Clauses [6.1](#), [7.1.2](#) and [7.2](#))

## CLEANING OF ALUMINIUM ALLOY GAS CYLINDER

**WARNING** — Ensure the chemical cleaning product is marked ‘suitable for aluminium’, otherwise serious damage will occur. To ensure gas compatibility completely remove the cleaning agent, or check that the final cleansing operation is compatible with the intended gas service.

**D-1 INTERNAL**

Aluminium alloy cylinders in normal service can accumulate internal contamination which may detrimentally affect use. [Table 7](#) illustrates procedures for cleaning the interior of aluminium alloy cylinders.

**D-2 EXTERNAL**

The following procedures are examples for cleaning external surfaces:

- a) Soap and water;
- b) Solvent wipe; and
- c) Scouring pad and water.

**Table 7 Procedures for Cleaning the Interior of Aluminium Alloy Cylinders**

(Clause D-1)

SI No.	Contamination	Cleaning Method
(1)	(2)	(3)
i)	Moisture or loose particles	Steam clean and blow dry
ii)	Oil and grease	Degrease with suitable solvent, steam clean and blow dry
iii)	Odour	Rinse with solution of sodium bicarbonate, then rinse with solution of acetic acid, steam clean and blow dry
iv)	Corrosion	Tumble with aluminium oxide chips or pellets, or glass beads, steam clean and blow

NOTE — Ensure all traces of cleaning agent have been removed. For temperature/time (see [12.1.2](#)).

ANNEX E

(Clause [10.2.2](#))

**PROOF PRESSURE TEST OF GAS CYLINDERS**

**E-1 GENERAL**

This annex gives details of a method of carrying out a proof pressure test on gas cylinders. Other acceptable methods may be employed.

**E-2 TEST EQUIPMENTS**

**E-2.1** All rigid pipework, flexible tubing, valves, fittings and components forming the pressure system of the test equipment shall be designed to withstand a pressure of 1.5 times the maximum test pressure of any cylinder that may be tested. Flexible tubing shall have sufficient wall thickness to prevent kinking.

**E-2.2** Pressure gauges shall be checked for accuracy against a calibrated gauge at regular intervals, and in any case not less frequently than once a month. The pressure gauge shall be chosen such that the test pressure is approximately between 1/3 and 2/3 the value capable of being measured on the pressure gauge.

**E-2.3** The design and installation of the equipment, the connection of the cylinders and the operating procedures, shall be such as to avoid trapping air in the system when a liquid medium is used.

**E-2.4** All joints within the system shall be leak-tight.

**E-2.5** A suitable device shall be fitted to the test equipment to ensure that no cylinder is subjected to a pressure in excess of its test pressure by more than the tolerances in [E-3.3](#).

**E-3 TEST METHOD**

**E-3.1** More than one cylinder may be tested at a time provided that they all have the same test pressure. In case of leakage, the leaking cylinder(s) shall be isolated. All other cylinders shall be re-tested.

**E-3.2** Before applying pressure the external surface of the cylinder(s) shall be dry.

**E-3.3** The pressure applied shall not be below the test pressure and shall not exceed the test pressure by 3 percent or 10 bar, whichever is the lower.

**E-3.4** On attaining the test pressure, the cylinder(s) shall be isolated from the pump and the pressure held for a minimum period of 30 s.

**E-3.5** If there is a leakage in the pressure system it shall be corrected and the cylinder(s) re-tested.

## ANNEX F

(Clause 10.2.3)

## VOLUMETRIC EXPANSION TESTING OF GAS CYLINDERS

## F-1 GENERAL

This annex gives details of the following two methods of determining the volumetric expansion of aluminium alloy gas cylinders:

- a) Water jacket method (preferred method); and
- b) Non-water jacket method.

The water jacket method volumetric expansion test may be carried out on equipment with a levelling burette or with a fixed burette or by weighing the mass of water displaced.

## F-2 TEST EQUIPMENT

The following requirements are general to the methods of test:

- a) Hydraulic test pressure pipelines shall be capable of withstanding a pressure of 1.5 times the maximum test pressure of any cylinder that may be tested;
- b) Glass burettes shall be of sufficient length to contain the full volumetric expansion of the cylinder and shall have bores of uniform diameter such that the expansion can be read to an accuracy of 1 percent or 0.1 ml, whichever is the greater;
- c) Weighing scales shall be to an accuracy of 1 percent or 0.1 g, whichever is the greater;
- d) Pressure gauges shall be of the accuracy class 1 with a scale appropriate to the test pressure. They shall be tested at regular intervals in any case but not less frequently than once per month;
- e) A suitable device shall be employed to ensure that no cylinder is subjected to a pressure in excess of its test pressure;
- f) Pipe work should utilize long bends in preference to elbow fittings and pressure pipes should be as short as possible. Flexible tubing should be capable of withstanding 1.5 times the maximum test pressure in the equipment and have sufficient wall thickness to prevent kinking;

- g) All joints should be leak-tight; and
- h) When installing equipment, care should be taken to avoid trapping of air in the system.

## F-3 WATER JACKET VOLUMETRIC EXPANSION TEST

## F-3.1 General Description

This method of test necessitates enclosing the water filled cylinder in a jacket also filled with water. The total and any permanent volumetric expansion of the cylinder are measured as the amount of water displaced by the expansion of the cylinder when under pressure and the amount of water displaced after the pressure has been released. The permanent expansion is calculated as a percentage of the total expansion. The water jacket should be fitted with a safety device capable of releasing the energy from any cylinder that can burst at test pressure.

It should be ensured that the entire external surface of the cylinder is wet without any bubbles.

An air bleed valve should be fitted to the highest point of the jacket.

Two methods of performing this test are described in [F-3.2](#) and [F-3.3](#). Other methods are acceptable provided that they are capable of measuring the total and, if any, the permanent volumetric expansion of the cylinder.

## F-3.2 Water Jacket Volumetric Expansion — Levelling Burette Method

The equipment should be installed as shown in [Fig. 13](#).

## F-3.2.1 Procedure

- a) Fill the cylinder with water and attach it to the water jacket cover;
- b) Seal the cylinder in the water jacket and fill the jacket with water, allowing air to bleed off through the air bleed valve;
- c) Connect the cylinder to the pressure line. Adjust the burette to zero level by

manipulation of the jacket filling valve and drain valve. Raise the pressure to 2/3 of the test pressure, stop pumping and close the hydraulic pressure line valve. Check that the burette reading remains constant;

- d) Re-start the pump and open the hydraulic pressure line valve until the cylinder test pressure is reached. Close the hydraulic pressure line valve and stop pumping;
- e) Lower the burette until the water level is at the zero mark on the burette support. Take a reading of the water level in the burette. This reading is the total expansion and shall be recorded on the test certificate;
- f) Open the hydraulic line drain valve to release the pressure from the cylinder. Raise the burette until the water level is at the zero mark on the burette support. Check that pressure is at zero and that water level is constant;
- g) Read the water level in the burette. This reading is the permanent expansion, if any, and shall be recorded on the test certificate; and
- h) Check that the permanent expansion as determined by the following equation.

$$\frac{\text{Permanent expansion}}{\text{Total expansion}} \times 100 \% = \text{Percent permanent expansion}$$

Percent permanent extension shall not exceed the percentage given in the design specification.

### F-3.3 Water Jacket Volumetric Expansion Test — Fixed Burette Method

The equipment should be installed as shown in [Fig. 14](#).

#### F-3.3.1 Procedure

The procedure for this method of test is similar to that described in [F-3.2](#) except that the burette is fixed.

- a) Follow procedures [F-3.2.1\(a\)](#) and [F-3.2.1\(b\)](#).
- b) Connect the cylinder to the pressure line.
- c) Adjust the water level to a datum. Apply pressure until the test pressure is reached and record the burette reading. The reading above the datum is the total expansion, and shall be recorded on the test certificate.
- d) Release the pressure and record the burette reading. The reading above the datum is the permanent expansion and shall be recorded on the test certificate.

- e) Check that the permanent volumetric expansion as determined by the following equation:

$$\frac{\text{Permanent Expansion}}{\text{Total Expansion}} \times 100 \% = \text{Percent Permanent Expansion}$$

Percent permanent expansion shall not exceed the percentage given in the design specification.

## F-4 NON-WATER JACKET VOLUMETRIC EXPANSION TEST

### F-4.1 General Description

This method consists of measuring the amount of water passed into the cylinder under proof pressure, and on release of this pressure, measuring the water returned to the manometer. It is necessary to allow for the compressibility of water and the volume of the cylinder under test to obtain true volumetric expansion. No fall in pressure under this test is permitted.

The water used should be clean and free of dissolved air. Any leakage from the system or the presence of free or dissolved air shall result in false readings.

The equipment should be installed as shown in [Fig. 15](#). [Figure 15](#) illustrates diagrammatically the different parts of the apparatus. The water supply pipe should be connected to an overhead tank as shown, or to some other supply giving a sufficient head of water.

### F-4.2 Requirement for Testing

The apparatus shall be arranged such that all air can be removed and that accurate readings can be determined of the volume of water required to pressurize the filled cylinder and of the volume expelled from the cylinder when depressurized. In the case of larger cylinders, it may be necessary to augment the glass tube with metal tubes arranged in the manifold.

If a single acting hydraulic pump is used, care shall be taken to ensure that the piston is in the back position when the water levels are noted.

### F-4.3 Test Method

- a) Completely fill the cylinder with water and determine the weight of water required;
- b) Connect the cylinder to the hydraulic test pump through the coil and check that all valves are closed;



- c) Fill the pump and system with water from tank 1 by opening valves 7, 10 and 11 (see [Fig. 15](#));
- d) To ensure the expulsion of air from the system, close the air-bleed and bypass valves and raise the system pressure to approximately one-third of the test pressure. Open the bleed valve to release the trapped air by reducing the system pressure to zero, and re-close the valve. Repeat, if necessary;
- e) Continue to fill the system until the level in the glass manometer is approximately 300 mm from the top. Close the make-up valve and mark the water level with a pointer, leaving the isolating and air-bleed valves open. Record the level;
- f) Close the air-bleed valve. Raise the pressure in the system until the pressure gauge records the required test pressure. Stop the pump and close the hydraulic line valve. After approximately 30 s there should be no change in either the water level or the pressure. A change in level indicates leakage. A fall in pressure, if there is no leakage, indicates that the cylinder is still expanding under pressure;
- g) Record the fall in water level in the glass tube (provided that there has been no leakage, all the water drained from the glass tube shall have been pumped into the cylinder to achieve the test pressure). The difference in water level is the total volumetric expansion;
- h) Open the hydraulic main and bypass valves slowly to release the pressure in the cylinder and allow the water so released to return to the glass tube. The water level should return to the original level marked by the pointer. Any difference in level shall denote the amount of permanent volumetric expansion in the cylinder, neglecting the effect of the compressibility of the water at the test pressure. The true permanent volumetric expansion of the cylinder is obtained by correcting for the compressibility of the water is given in [F-4.5](#);
- j) Before disconnecting the cylinder from the test rig, close the isolating valve. This will leave the pump and system full of water for the next test. [F-4.3\(d\)](#) shall, however, be repeated at each subsequent test; and

If permanent volumetric expansion has occurred,

record the temperature of the water in the cylinder.

#### F-4.4 Test Results

- a) The tests determine the volume of water required to pressurize the tilled cylinder to the test pressure;
- b) The total mass and temperature of water in the cylinder are known, enabling the change in volume of the water in the cylinder owing to its compressibility to be calculated. The volume of water expelled from the cylinder when depressurized is known. Thus the total volumetric expansion and the permanent volumetric expansion can be determined; and
- c) The permanent volumetric expansion shall not exceed the percentage given in the design specification.

#### F-4.5 Calculation of Compressibility of Water

The formula used for calculating the reduction in volume of water due to its compressibility is as follows:

$$C = \frac{WP[K - 0.68P]}{10^5}$$

where

- C = reduction in volume of water due to its compressibility, in cm<sup>3</sup>;
- W = weight of water, in kg;
- P = pressure, in bar; and
- K = compressibility factor for individual temperature as listed in [Table 8](#).

#### F-4.6 Calculation

*Example:*

Test pressure	: 232 bar
Weight of water in cylinder at zero gauge pressure	: 113.8 kg
Temperature of water	: 15 °C
Water forced into cylinder to raise pressure to 232 bar	: 1 745 cm <sup>3</sup> (or 1 745 kg)
Total weight of water in cylinder at 232 bar	: 113.8 + 1.745 = 115.545 kg
Water expelled from cylinder to depressurize	: 1 742 cm <sup>3</sup>
Permanent expansion =	: 3 cm <sup>3</sup>

$$1\,745\text{ cm}^3 - 1\,742\text{ cm}^3$$

From Table 5 factor for 15 °C  
= 0.047 25

$$C = \frac{WP[K - 0.68P]}{10^5}$$

$$= 115.545 \times 232 \left( 0.047\,25 - \frac{0.68 \times 232}{10^5} \right)$$

$$= 1\,224.314\text{ cm}^3$$

$$\begin{aligned} \text{Total volumetric expansion} &= 1\,745\text{ cm}^3 - 1\,224.31\text{ cm}^3 \\ &= 520.686\text{ cm}^3 \\ \text{Permanent expansion percent} &= \frac{3 \times 100}{520.686} \\ &= 0.58\text{ percent} \end{aligned}$$

NOTE — In the above example calculation, allowance for pipe stretch has been neglected.

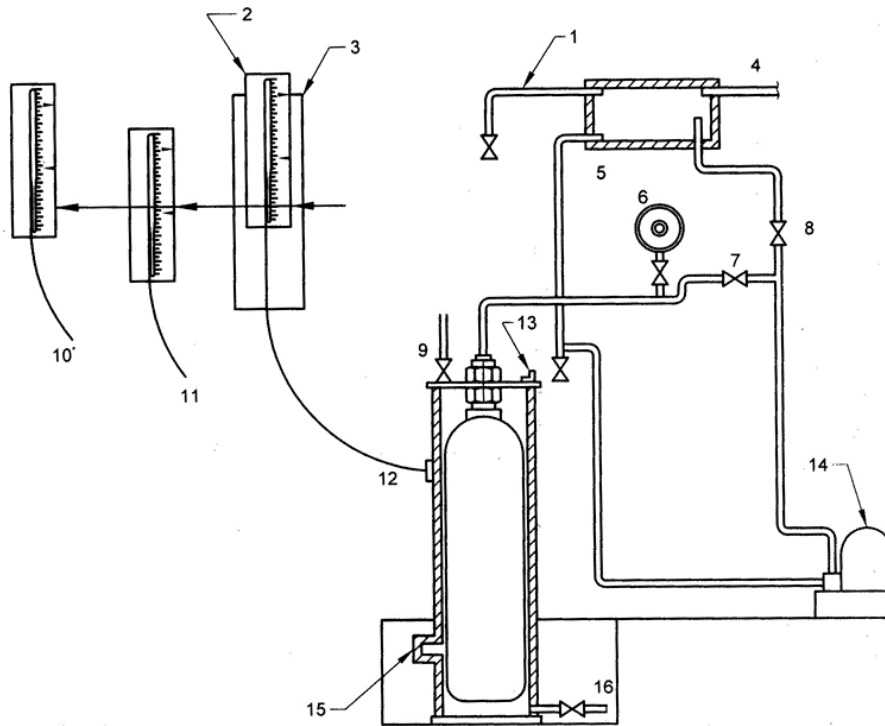

Key

- 1 Overflow
- 2 Calibrated burette sliding in fixed frame
- 3 Fixed frame
- 4 Water supply
- 5 Water and eye level
- 6 Pointer attached to fixed frame at water level
- 7 Hydraulic line level
- 8 Priming valve
- 9 Jacket filling valve
- 10 Position when pressure is released – Reading = Permanent expansion
- 11 Position at test pressure – Reading = Total expansion
- 12 Position before pressurization
- 13 Air bleed valve
- 14 Pump
- 15 Relief device
- 16 Drain

FIG. 13 WATER JACKET VOLUMETRIC EXPANSION TEST (LEVELLING BURETTE METHOD)

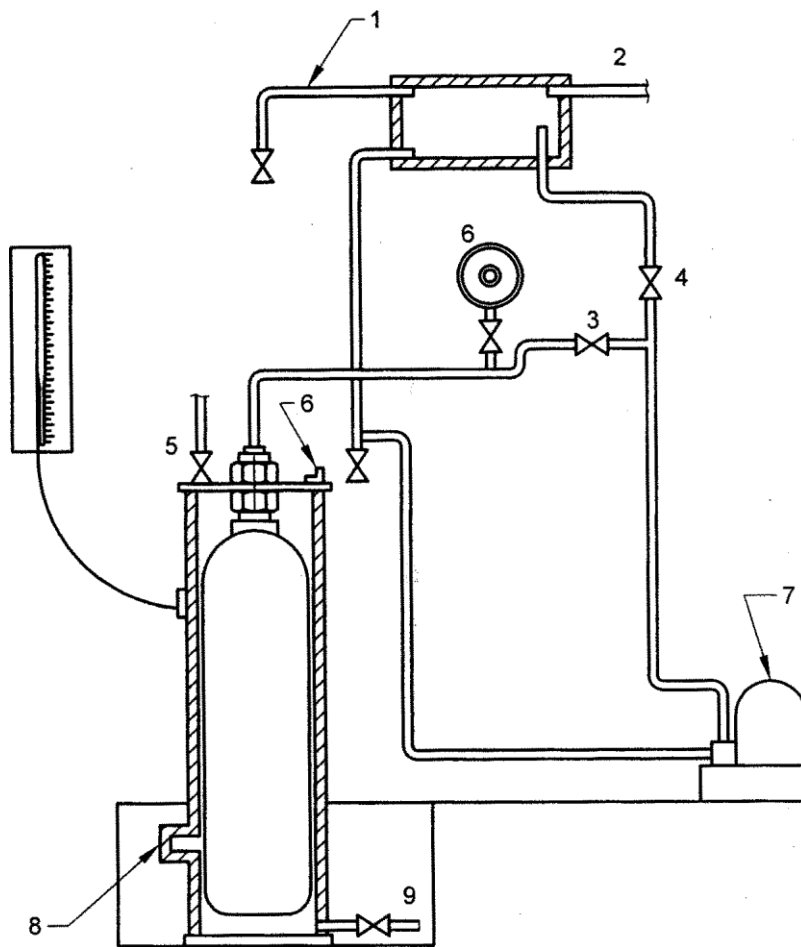

Key

- 1 Overflow
- 2 Water supply
- 3 Hydraulic line valve
- 4 Priming valve
- 5 Jacket filling valve
- 6 Air bleed valve
- 7 Pump
- 8 Relief device
- 9 Drain

FIG. 14 WATER JACKET VOLUMETRIC EXPANSION TEST (FIXED BURETTE METHOD)

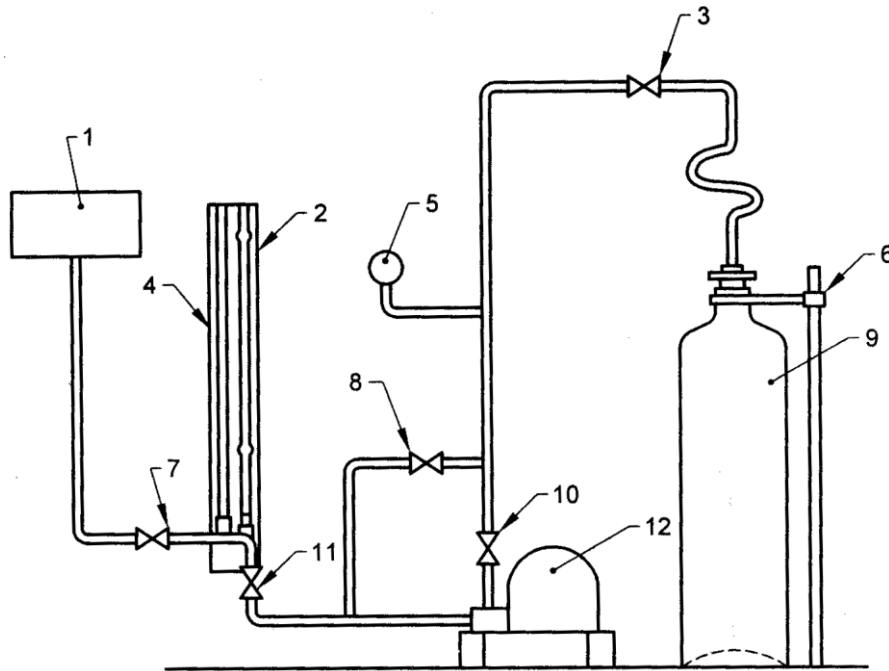

*Key*

- 1 Supply tank
- 2 Calibrated glass burette
- 3 Air-bleed valve
- 4 Adjustable pointer
- 5 Main pressure gauge
- 6 Cylinder support
- 7 Make-up valve
- 8 Bypass valve
- 9 Test cylinder
- 10 Hydraulic volumetric expansion test line valve
- 11 Pump suction isolating valve
- 12 Pump

FIG. 15 NON-WATER JACKET METHOD: DIAGRAMMATIC LAYOUT OF CONTAINER TESTING APPARATUS

**Table 8 Compressibility Factor,  $K$**

(*Clause F-4.5*)

SI No.	Temperature °C	$K$	Temperature °C	$K$	Temperature °C	$K$
(1)	(2)	(3)	(4)	(5)	(6)	(7)
i)	6	0.049 15	13	0.047 59	20	0.046 54
ii)	7	0.048 86	14	0.047 42	21	0.046 43
iii)	8	0.048 60	15	0.047 25	22	0.046 33
iv)	9	0.048 34	16	0.047 10	23	0.046 23
v)	10	0.048 12	17	0.046 95	24	0.046 12
vi)	11	0.047 92	18	0.046 80	25	0.046 04
vii)	12	0.047 75	19	0.046 68	26	0.045 94

## ANNEX G

(Clauses [10.3](#), [A-2.1](#) and [A-3](#))

## ULTRASONIC TEST

**G-1 GENERAL**

This annex specifies the ultrasonic testing (UT) of seamless gas cylinders of water capacity  $\geq 2$  litres within the framework of periodic inspections.

**G-2 REQUIREMENTS****G-2.1 General**

The cylindrical part of the cylinder, the transition to the shoulder, the transition at the base and critical zones of the base shall be tested ultrasonically. This shall be carried out using a mechanized test device (see [Fig. 16](#)). Where such a testing device is unable to carry out this inspection outside the cylindrical part, a supplementary manual examination shall be performed.

Since the effect of fire-exposure or heat-exposure to the cylinder material cannot be determined using UT, cylinders that are suspected to or have experienced this kind of exposure shall not be examined ultrasonically, unless they have been proven to be suitable for further service. See the fire damage information in [Table 5](#).

Cylinders which are suspected of fire or heat damage shall not be examined ultrasonically.

**G-2.2 Testing Equipment**

The installation shall have at least 5 ultrasonic probes suitably arranged (for example, see [Fig. 17](#)) to scan the whole surface of the cylindrical part of the cylinder, including the adjacent transitions to the base and shoulder.

The arrangement described above is an example. Other arrangements can be possible provided that the probes detected can be located from two opposing sides.

The pulse echo method shall be used to detect defects and measure wall thickness ultrasonically. The testing techniques used may either be the contact or the immersion type (see [Fig. 18](#)).

The cylinder wall shall be tested using UT probes (shear wave, angle of refraction about  $45^\circ$ ), diameter of probe less than 15 mm, operating with a frequency of 2 MHz to 10 MHz. The examination shall cover longitudinal defects in both circumferential directions (clockwise and

anti-clockwise) and transverse defects in both longitudinal directions (forward and backward).

The wall thickness measurement shall be performed using a normal probe (angle of refraction  $0^\circ$ ), diameter of probe less than 15 mm operating with a frequency of 2 MHz to 10 MHz. The tolerance of the wall thickness measurement shall lie in the range of  $\pm 0.1$  mm.

The cylinders to be tested and the search unit with the probes shall go through a rotating motion and translation relative to one another such that a helical scan is performed on the cylinder. The speeds of translation and rotation shall be constant within  $\pm 10$  percent (see [G-4.1](#)).

The ultrasonic test unit shall have a screen. The installation shall have an automatic alarm level for each probe which gives an automatic acoustic and visual signal when a fault signal (defect or below minimum wall thickness) is registered. A distinction in the alarm level between internal and external defect signal from a probe is desirable, but not necessary (see [Fig. 20A](#)).

The equipment shall be serviced regularly at least in accordance with the equipment manufacturer's recommendations to ensure that its accuracy is maintained. Inspection records shall be kept.

**G-2.3 Manual Ultrasonic Unit**

The requirements laid down in [G-2.2](#) shall apply as appropriate for the selection of the probes and servicing of the unit.

**G-2.4 Cylinders**

The outer and inner surfaces of any cylinder to be tested ultrasonically shall be in a suitable condition for an accurate and reproducible test. In particular, the external surface shall be free of loose paint, dirt and oil. An ultrasonic test is only valid when the noise signals caused by the surface are at least 50 percent below the corresponding reference signal.

**G-2.5 Personnel**

The test equipment shall be operated and its operation supervised by qualified and experienced personnel only. The tester shall be certified to level 1 for ultrasonic testing. The testing organization shall have a supervisor qualified to at least level 2 for ultrasonic testing.

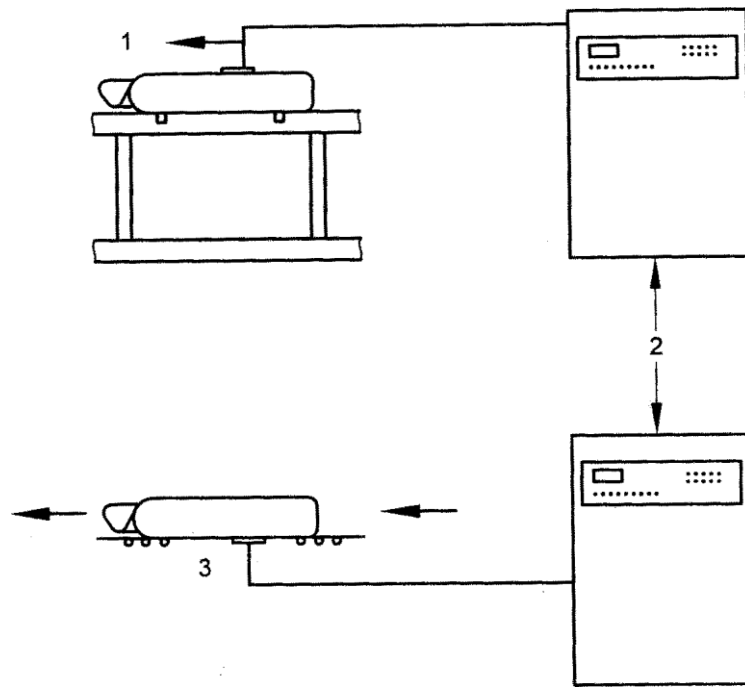

Key

- 1 UT probes moving
- 2 Ultrasonic test equipment
- 3 Cylinder moving

FIG. 16 TWO TYPES OF ULTRASONIC TEST DEVICES FOR GAS CYLINDERS (SCHEMATIC)

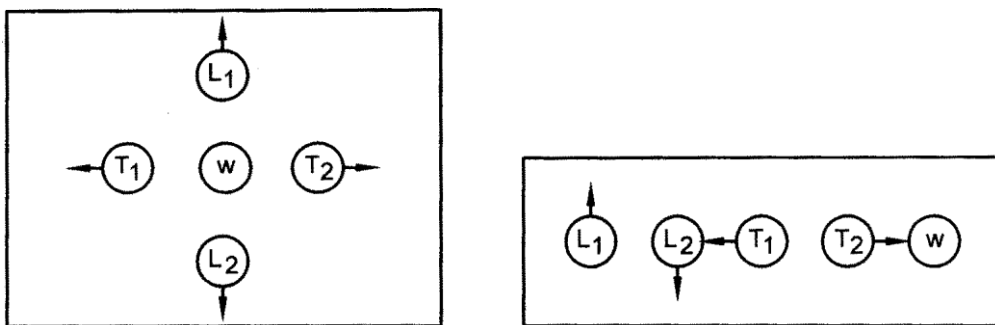

Key

- L<sub>1</sub>, L<sub>2</sub> Longitudinal probes
- T<sub>1</sub>, T<sub>2</sub> Transverse probes
- w Wall thickness probes

FIG. 17 ARRANGEMENT OF PROBES (EXAMPLES)

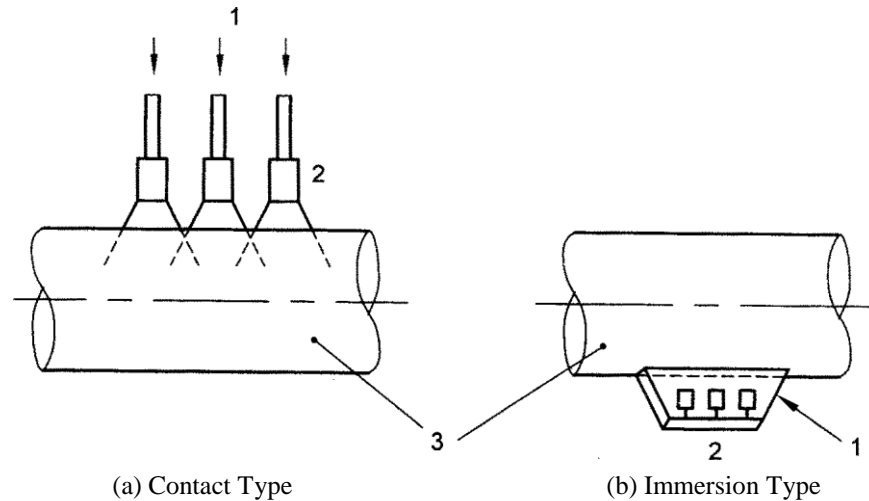

### Key

- 1 Water
- 2 Probes
- 3 Cylinder

FIG. 18 COUPLING TECHNIQUES

## G-3 CALIBRATION

### G-3.1 General

For calibrating the UT defect testing and wall thickness measurement, a calibration specimen with notches shall be used. A specimen of convenient length shall be prepared from a cylinder corresponding to the diameter, wall thickness, external surface finish and material (same range of chemical composition and mechanical properties) of the cylinder to be tested. Different coatings (for example, powder coatings versus wet painting) and thicknesses give different acoustic responses that can require the use of a dedicated calibration specimen.

### G-3.2 Defect Detection

For manual and mechanized defect testing purposes, following four rectangular notches are required as reference notches in the calibration specimen (see Fig. 19):

- a) Inner notch in longitudinal direction;
- b) Inner notch in transverse direction;
- c) Outer notch in longitudinal direction; and
- d) Outer notch in transverse direction.

With the following dimensions in each case:

- a) Length  $L = 50$  mm;
- b) Depth  $D = 5 \pm 0.75$  percent of nominal wall

- thickness  $S$ ; and
- c) Width  $W = \leq 2 D$ .

The notches may be produced either by means of electrical erosion or sawing. The bottom corners of the notch may be rounded. The notches shall be located such that there is no interference from any other defect in the reference standard. The shape and dimensions of the reference standard shall be verified.

For the first step during the calibration procedure the ultrasonic testing equipment shall be adjusted in such a way that under test conditions an alarm signal is given when the UT echoes from the reference notches exceed the alarm level (see Fig. 20A). This sensitivity is the basic sensitivity.

During the second step of the calibration procedure the basic sensitivity shall be changed to a testing sensitivity such that for testing aluminium alloy gas cylinders the ultrasonic sensitivity shall be lowered from the basic sensitivity by 2 dB (see Fig. 20B).

### G-3.3 Wall Thickness

To calibrate the manual and mechanized wall thickness measurement, an area on the calibration specimen shall be used of which the exact wall thickness is known.

To calibrate the manual and automated wall thickness measurement, a patch with a diameter

equal to at least 2 times the effective beam width at the point of entrance on the calibration specimen shall be used, the exact wall thickness being known.

The minimum wall thickness of the gas cylinder defined in the type approval is set as the alarm level in the evaluation unit of the ultrasonic wall thickness measuring device.

### **G-3.4 Time of Calibration**

The UT equipment shall be calibrated at least at the beginning and at the end of each shift, regardless of length, and when any equipment affecting UT is changed, for example, change of transducer, transducer cable, wheel, encoder, drive belts. If during the check, the presence of the respective reference notch is not detected, all cylinders tested subsequently to the last acceptable check shall be re-tested after the equipment has been re-calibrated.

## **G-4 PERFORMANCE OF THE TEST**

### **G-4.1 Defect Detection in Cylindrical Part by Mechanized Installation**

The cylindrical part of the cylinder and the transitions to the shoulder and to the base shall be tested for longitudinal and transverse defects using a mechanized testing device.

The rotational speed of the cylinder and the pulse repetition frequency of the probes shall be mutually adjusted in such a way that the displacement distance of each probe in the circumferential direction between two successive test pulses is less than 1 mm.

The minimum design wall thickness of the cylinder

shall be known. This value can be obtained from one of the following: the cylinder marking, the type approval, a calculation, etc. This value is set as the alarm level in the evaluation unit of the ultrasonic wall thickness measuring device.

The rotational and axial speed used during the test shall be mutually adjusted in such a way that the pitch of the helix is less than the diameter of one probe (at least a 10 percent overlap shall be guaranteed) and relates to the effective beam so as to ensure 100 percent coverage.

### **G-4.2 Defect Detection in Cylinder Ends by Manual Testing**

The critical areas of the ends, especially the transition zone of concave bases, shall be carefully checked. The extent of the test depends on the type of base, the position of the critical zones, the form of possible defects, the accessibility of the test surface (in the case of foot rings) and the roughness of the external surface. [Fig. 21](#) shows how the test may be conducted for the above mentioned conditions.

### **G-4.3 Wall Thickness Measurement by Mechanized Installation**

One hundred percent of the cylindrical part shall be examined with a normal probe.

### **G-4.4 Wall Thickness Measurement by Manual Testing**

The transition area to the base and the base itself shall be examined with a normal ultrasonic probe, if not already performed using mechanical devices.



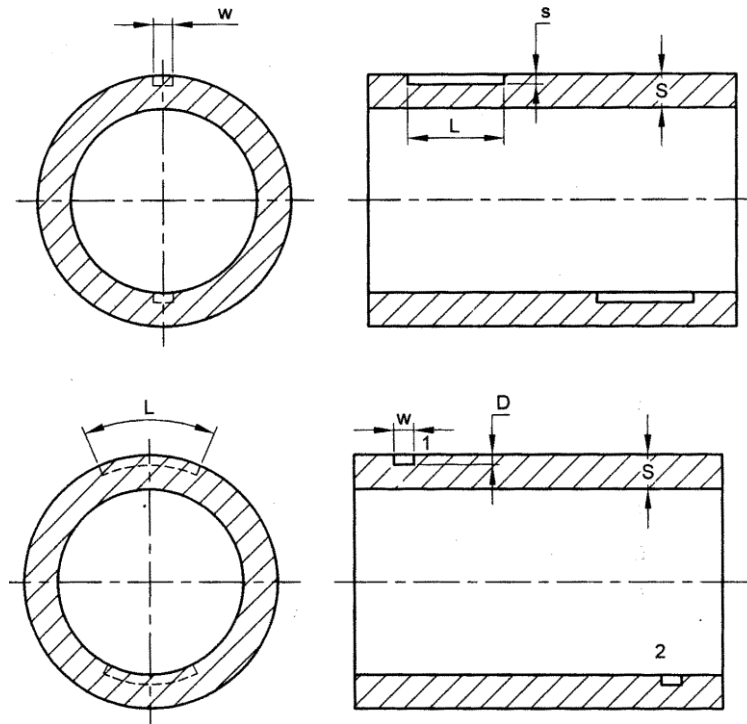

Key

- 1 Outer notch
- 2 Inner notch
- L Length of notches : 50 mm
- D Depth of notches :  $(5 \pm 0.75)$  percent
- W Width of notches :  $< 2D$
- S Nominal wall thickness

FIG. 19 REFERENCE STANDARDS

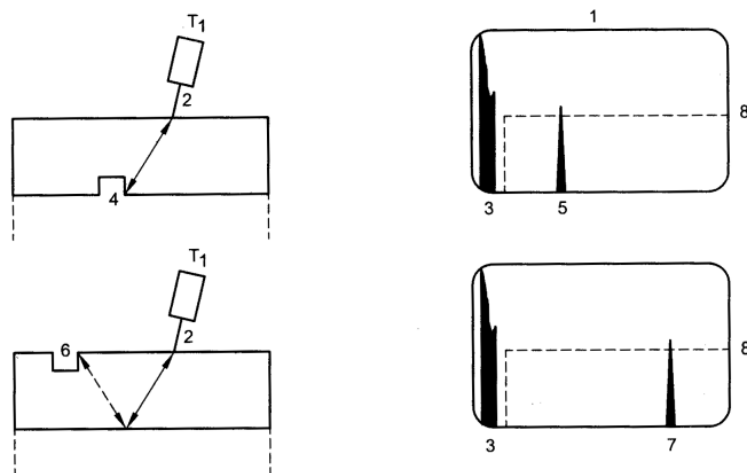

i) CALIBRATION SPECIMEN —  
INNER REFERENCE NOTCH IN  
TRANSVERSE DIRECTION

ii) CALIBRATION SPECIMEN —  
OUTER REFERENCE NOTCH IN  
TRANSVERSE DIRECTION

*Key*

- 1 Screen
- 2 Calibration specimen wall
- 3 UT signal trace from calibration specimen wall
- 4 Inner reference notch
- 5 UT signal trace from inner reference notch
- 6 Outer reference notch
- 7 UT signal trace from outer reference notch
- 8 Alarm level

FIG. 20A CALIBRATION PROCEDURE, STEP 1 TESTING OF BASIC SENSIVITY

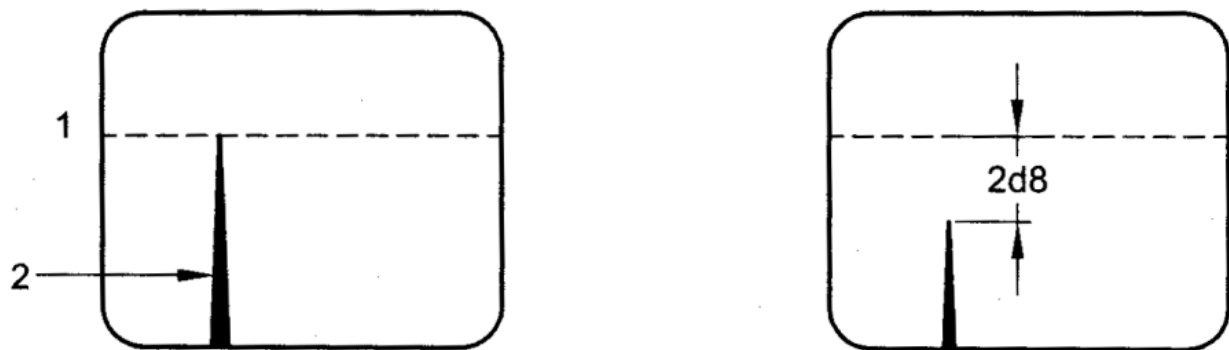

i) BASIC SENSIVITY

ii) TESTING SENSIVITY

*Key*

- 1 Alarm level
- 2 Signal of reference notch

FIG. 20B CALIBRATION PROCEDURE, STEP 2 ESTABLISHMENT OF SENSIVITY CONTROL

FIG. 20 CALIBRATION PROCEDURE

**G-5 INTERPRETATION OF RESULTS**

Gas cylinders tested to the testing sensitivity in accordance with [G-3.2](#) and [G-3.3](#) where no defect signal above the alarm level has been recorded have passed the test. Where a defect signal above the alarm level (defect or below minimum wall thickness) has been recorded (*see* [Fig. 21](#)) the cylinder shall be re-evaluated with respect to the defect rejection limits in accordance with [Annex B](#).

**G-6 RECORDS**

In addition to the required record according to [12.6](#),

the following information shall be recorded:

- a) Identification of ultrasonic equipment used;
- b) An ultrasonic test symbol for example UT; and
- c) Results of examination. If a re-evaluation according to [Annex B](#) has been necessary following detection of a defect, the basis of re-evaluation shall be recorded.

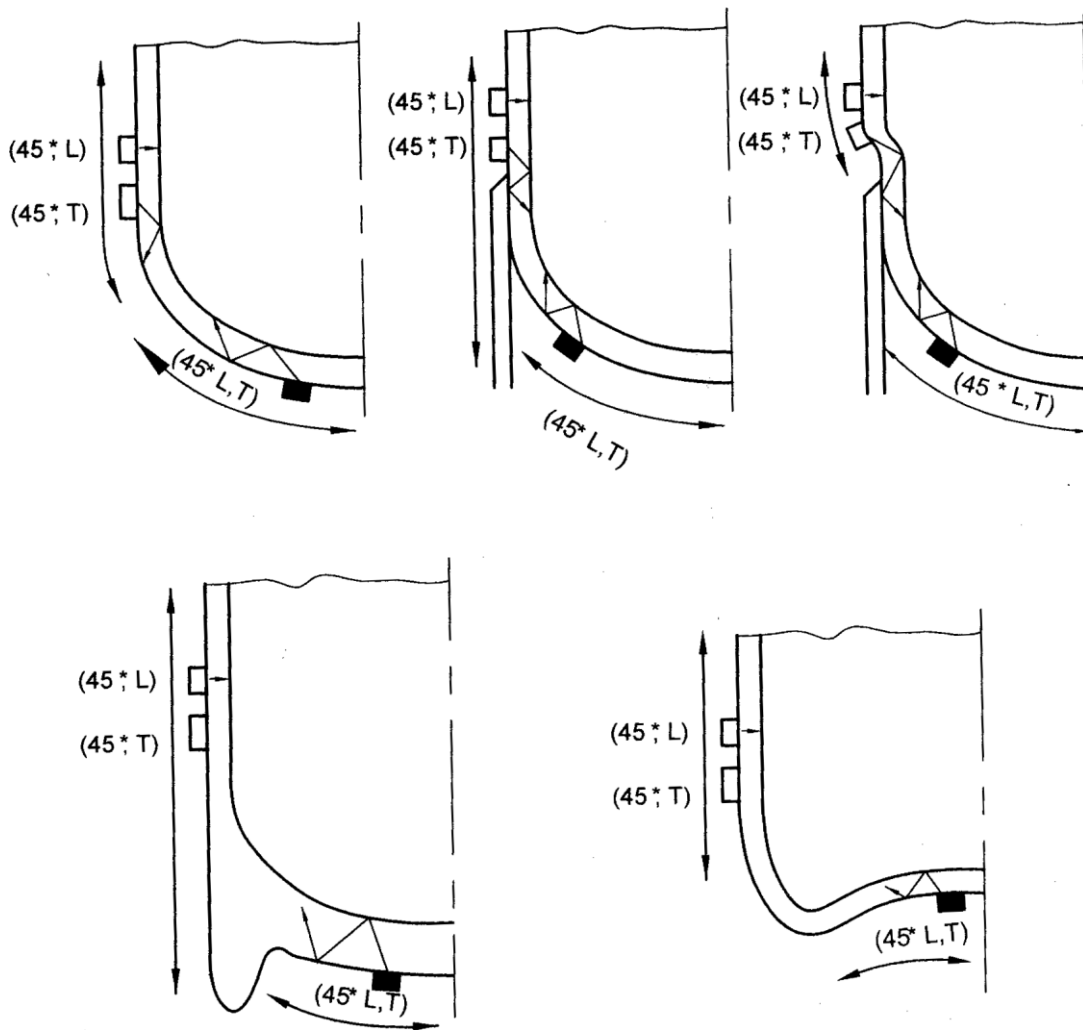

*Key*

- L Longitudinal of the base shape
- T Transverse of the base shape
- Manual (common practice)
- Mechanized (common practice)

FIG. 21 DEFECT DETECTION

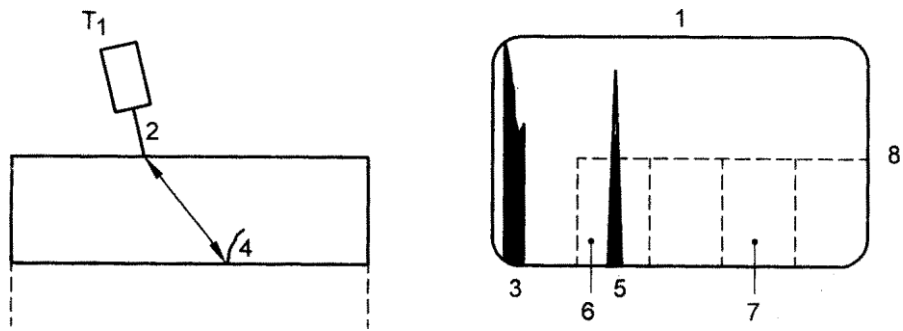

*Key*

- 1 Screen
- 2 Cylinder wall
- 3 UT Signal from cylinder wall
- 4 Crack on internal surface
- 5 UT Signal from crack
- 6 Region of signals from cracks on internal surface
- 7 Region of signals from cracks on external surface
- 8 Alarm level

FIG. 21 DETECTION OF CRACK IN TRANSVERSE DIRECTION (EXAMPLE)

**ANNEX H**

**(Clause 11)**

**INSPECTION AND MAINTENANCE OF VALVES AND THEIR CONNECTIONS —  
RECOMMENDED PROCEDURES**

**H-1** Check all threads to ensure the thread diameters, form, length, and taper are satisfactory. If threads show signs of distortion, deformation, or burring, rectify these faults. Excessive thread damage or serious deformation of the valve body, hand wheel, spindle or other components is cause for replacement. Maintenance of the valve includes general cleaning together with replacement of

elastomers and worn or damaged components, packing and safety devices, where necessary. Where the use of lubricants/elastomers is permitted, use only those approved for the gas service, particularly oxidizing gas service. After the valve has been re-assembled check for leakage and correct operation. This can be done prior to the valve being refitted to the cylinder, or during and after the first gas charge subsequent to the inspection and test of the cylinder.

## ANNEX J

(Clause 12.6)

## TEST DATE RINGS FOR CYLINDERS

Table 9 System Using Colour and Shape of Rings to Identify Periodic Inspection Dates

SI No.	Year	Colour	Shape
(1)	(2)	(3)	(4)
i)	2013 <sup>1</sup>	Red	Circle
ii)	2014	Blue	Circle
iii)	2015	Yellow	Circle
iv)	2016	Green	Circle
v)	2017	Black	Circle
vi)	2018	Grey	Circle
vii)	2019	Red	Hexagon
viii)	2020	Blue	Hexagon
ix)	2021	Yellow	Hexagon
x)	2022	Green	Hexagon
xi)	2023	Black	Hexagon
xii)	2024	Grey	Hexagon
xiii)	2025	Red	Square
xiv)	2026	Blue	Square
xv)	2027	Yellow	Square
xvi)	2028	Green	Square
xvii)	2029	Black	Square
xviii)	2030	Grey	Square
xix)	2031 <sup>1</sup>	Red	Circle
xx)	2032	Blue	Circle
xxi)	2033	Yellow	Circle
xxii)	2034	Green	Circle
xxiii)	2035	Black	Circle
xxiv)	2036	Grey	Circle

NOTE — Systems other than the one specified in Table 9 are in use, and the same system as shown in Table 9 is used using different colours. Table 9 are in use, and the same system as shown in Table 9 is used using different colours.

<sup>1</sup> The sequence of colour and shape of periodic inspection date rings is to be repeated on an 18-year cycle. Hence, 2031 is a repeat of 2013.

## ANNEX K

(Foreword)

## COMMITTEE COMPOSITION

Gas Cylinder Sectional Committee, MED 16

<i>Organization</i>	<i>Representative(s)</i>
Petroleum and Explosive Safety Organization, Nagpur	SHRI P. KUMAR ( <b>Chairperson</b> ) SHRI K. S. RAO ( <i>Alternate I</i> ) SHRI P. SEENIRAJ ( <i>Alternate II</i> )
All India Industrial Gases Manufacturers Association, New Delhi	SHRI SAKET TIKU SHRI K. R. SAHASRANAM ( <i>Alternate</i> )
Ashok Leyland Limited, Chennai	SHRI VED PRAKASH GAUTAM SHRI FAUSTINO V. ( <i>Alternate</i> )
Automotive Research Association of India, Pune	DR S. S. THIPSE SHRI SANDEEP RAIRIKAR ( <i>Alternate</i> )
Bharat Heavy Electricals Limited, Project Engineering Management, Noida	SHRI SAYAN ROY SHRI KARAN YADAV ( <i>Alternate</i> )
Bharat Petroleum Corporation Limited, Mumbai	SHRI RAJWINDER SINGH PANESAR SHRI AAKASH AGARWAL ( <i>Alternate</i> )
Bhiwadi Cylinders Private Limited, New Delhi	SHRI MANVINDER SINGH SHRI SUNIL K. DEY ( <i>Alternate</i> )
Directorate General of Quality Assurance, Ministry of Defence, New Delhi	COL SABIR HUNDEKAR SHRI DHRITESH PRAKASH SANA ( <i>Alternate</i> )
Everest Kanto Cylinder Limited, Mumbai	SHRI AYUSH PAWAR SHRI GHANSHYAM GOYAL ( <i>Alternate I</i> ) SHRI A. S. V. S. PRASAD ( <i>Alternate II</i> )
Gujarat Gas Limited, Ahmedabad	SHRI DHARMESH SAILOR SHRI RAVI RAVIPALLI ( <i>Alternate</i> )
Hindustan Petroleum Corporation Limited, Mumbai	SHRI RAKESH G. KHADE SHRI SHIVA SHANKAR ( <i>Alternate I</i> ) SHRI DINESH PANGTEY ( <i>Alternate II</i> )
Ideal Engineers Hyderabad Private limited, Hyderabad	SHRI SATISH KABRA SHRI KUNAL KABRA ( <i>Alternate</i> )
Indian Oil Corporation Limited, Mumbai	SHRI SOUMITRA CHAKRABORTY SHRI CHANDRAKANT GHATOL ( <i>Alternate</i> )
Indraprastha Gas Limited, New Delhi	SHRI RAKESH KISHAN AGRAWAL SHRI BIMAL KARAN ( <i>Alternate I</i> ) SHRI AVIRAL RAJEEV ( <i>Alternate II</i> )
INOX India Limited, Vadodara	SHRI DEEPAK V. ACHARYA SHRI NITIN JANSARI ( <i>Alternate</i> )
International Industrial Gases Limited, Howrah	SHRI DEVENDRA K. GARG SHRI NIKHILESH K. GARG ( <i>Alternate</i> )

<i>Organization</i>	<i>Representative(s)</i>
Jai Maruti Gas Cylinders Private Limited, Gwalior	SHRI MANU K. NIGAM
Kosan Industries Limited, Surat	SHRI GIRISHBHAI K. DESAI SHRI S. B. BOLMAL ( <i>Alternate</i> )
LPG Equipment Research Centre, Bengaluru	SHRI T. D. SAHU SHRI SANTOSH KUMAR GUPTA ( <i>Alternate</i> )
Linde India Limited, Kolkata	SHRI RAMANA VUTUKURU
Mahanagar Gas Limited, Mumbai	SHRI S. MURALI SHRI MILIND M. RANADE ( <i>Alternate I</i> ) SHRI SACHIN GUMASTE ( <i>Alternate II</i> )
Maruti Suzuki Indian Limited, Gurugram	SHRI GURURAJ RAVI SHRI ARUN KUMAR ( <i>Alternate I</i> ) SHRI RAJESH KUMAR ( <i>Alternate II</i> )
RDCIS, Steel Authority of India Limited, Ranchi	SHRI K. K. SINGH SHRI SANTOSH KUMAR ( <i>Alternate</i> )
Research and Development Estt (Engineers), Pune	DR SHANKAR BHAUMIK SHRI TAMHANKAR RAVINDRA ( <i>Alternate</i> )
Society of Indian Automobile Manufacturers, New Delhi	SHRI K. K. GANDHI SHRI AMIT KUMAR ( <i>Alternate</i> )
Steel Authority Of India Limited (SAIL), Research & Development Centre for Iron & Steel, Ranchi	SHRI K.K.SINGH SHRI SANTOSH KUMAR ( <i>Alternate</i> )
Tata Motors Limited, Pune	SHRI PALLIPALAYAM GOWRISHANKAR SHRI SHAILENDRA DEWANGAN ( <i>Alternate</i> )
Tekno Valves, Kolkata	SHRI Y. K. BEHANI SHRI ROHIT BEHANI ( <i>Alternate</i> )
Trans Valves (India) Private Limited, Hyderabad	SHRI GAURAV JAIN SHRI PRADEEP KUMAR MATHUR ( <i>Alternate</i> )
Vanaz Engineers Private Limited, Pune	SHRI S. J. VISPUTE SHRI A. S. WAGH ( <i>Alternate</i> )
BIS Directorate General, New Delhi	SHRI NAVINDRA GAUTAM, SCIENTIST 'E'/ DIRECTOR AND HEAD (MECHANICAL ENGINEERING) [REPRESENTING DIRECTOR GENERAL ( <i>Ex-officio</i> )]

*Member Secretary*  
SHRI PRASOON YADAV  
SCIENTIST 'B'/ASSISTANT DIRECTOR  
(MECHANICAL ENGINEERING), BIS



**IS 16017 : 2023**

Dissolved Acetylene Cylinders, Generators, Acetylene Pipe Lines and High Pressure Gas Cylinders  
Subcommittee, MED 16:3

<i>Organization</i>	<i>Representative(s)</i>
Linde India Limited, Kolkata	SHRI VUTUKURU RAMANA ( <b><i>Convener</i></b> )
Adani Gas Limited, Ahmedabad	SHRI PEEYUSH TRIPATHI SHRI AMIT MALIK ( <i>Alternate</i> )
Al-Can Exports Private Limited, Thane	SHRI VIJAY K PARIKH SHRI SUMIR VIJAY PARIKH ( <i>Alternate</i> )
All India Industrial Gases Manufacturers Association, New Delhi	SHRI SAKET TIKU SHRI K. R SAHASRANAM ( <i>Alternate</i> )
Ashok Leyland Limited, Chennai	SHRI VED PRAKASH GAUTAM SHRI FAUSTINO V. ( <i>Alternate</i> )
Automotive Research Association of India, Pune	DR S. S. THIPSE SHRI SANDEEP RAIKAR ( <i>Alternate</i> )
Bharat Petroleum Corporation Limited, Mumbai	SHRI RAJWINDER SINGH PANESAR SHRI AAKASH AGARWAL ( <i>Alternate</i> )
Directorate General of Quality Assurance, Ministry of Defence, New Delhi	COL SABIR HUNDEKAR
Everest Kanto Cylinder Limited, Mumbai	SHRI AYUSH PAWAR SHRI GHANSHYAM GOYAL ( <i>Alternate I</i> ) SHRI A.S.V.S. PRASAD ( <i>Alternate II</i> )
Hindalco Industries Limited, Mumbai	SHRI SOURABH MANOHAR SHRI DEVESH KUMAR ( <i>Alternate</i> )
Hindustan Petroleum Corporation Limited, Mumbai	SHRI RAKESH G. KHADE SHRI SHIVA SHANKAR ( <i>Alternate I</i> ) SHRI DINESH PANGTEY ( <i>Alternate II</i> )
Indian Oil Corporation (R and D Centre), Faridabad	SHRI ALOK SHARMA SHRI TAPAN BERA ( <i>Alternate</i> )
Indian Oil Corporation Limited, Mumbai	SHRI SOUMITRA CHAKRABORTY SHRI CHANDRAKANT GHATOL ( <i>Alternate</i> )
Indraprastha Gas Limited, New Delhi	SHRI RAKESH KISHAN AGRAWAL SHRI BIMAL KARAN ( <i>Alternate I</i> ) SHRI AVIRAL RAJEEV ( <i>Alternate II</i> )
International Industrial Gases Limited, Howrah	SHRI DEVENDRA K. GARG SHRI NIKHILESH K. GARG ( <i>Alternate</i> )

<i>Organization</i>	<i>Representative(s)</i>
Jai Maruti Gas Cylinders Private Limited, Gwalior	SHRI ASHOK K. NIGAM SHRI MANU K. NIGAM ( <i>Alternate</i> )
KVK corporation, Mumbai	SHRI R. CHANDGOTHIA SHRI V. CHANDGOTHIA ( <i>Alternate</i> )
Luxfer Uttam India Private Limited, Faridabad	SHRI KARAN BHATIA SHRI SANDEEP BHASIN ( <i>Alternate</i> )
Natural Gas Society, Noida	SHRI D. V. SHASTRY SHRI VIPIN CHANDRA CHITTODA ( <i>Alternate</i> )
Petroleum and Explosive Safety Organization, Nagpur	SHRI P. SEENIRAJ SHRI SRINIVASA RAO KETA ( <i>Alternate</i> )
Protego India Private Limited, Mumbai	SHRI PRASAD JAWAJI SHRI YOGESH SAHNI ( <i>Alternate I</i> ) MS JAIARTI RAI ( <i>Alternate II</i> )
Rama Cylinders Private Limited, Mumbai	SHRI MILIND W KHADKE SHRI C. L. KSHIRSAGAR ( <i>Alternate I</i> ) SHRI PRAMOD W. SANGWAI ( <i>Alternate II</i> )
Sahuwala Cylinders Private Limited, Vizag	SHRI P. K. GUPTA
Society of Indian Automobile Manufacturers (SIAM), Delhi	SHRI K. K. GANDHI SHRI AMIT KUMAR ( <i>Alternate</i> )
Tata Motors Limited, Pune	SHRI GOWRISHANKAR P. S. SHRI SHAILENDRA DEWANGAN ( <i>Alternate</i> )
Tekno Valves, Kolkata	SHRI ROHIT BEHANI SHRI Y. K. BEHANI ( <i>Alternate</i> )
Vanaz Engineers Private Limited, Pune	SHRI S. J. VISPUTE SHRI A. S. WAGH ( <i>Alternate</i> )





## Bureau of Indian Standards

BIS is a statutory institution established under the *Bureau of Indian Standards Act, 2016* to promote harmonious development of the activities of standardization, marking and quality certification of goods and attending to connected matters in the country.

### Copyright

BIS has the copyright of all its publications. No part of these publications may be reproduced in any form without the prior permission in writing of BIS. This does not preclude the free use, in the course of implementing the standard, of necessary details, such as symbols and sizes, type or grade designations. Enquiries relating to copyright be addressed to the Head (Publication & Sales), BIS.

### Review of Indian Standards

Amendments are issued to standards as the need arises on the basis of comments. Standards are also reviewed periodically; a standard along with amendments is reaffirmed when such review indicates that no changes are needed; if the review indicates that changes are needed, it is taken up for revision. Users of Indian Standards should ascertain that they are in possession of the latest amendments or edition by referring to the website-[www.bis.gov.in](http://www.bis.gov.in) or [www.standardsbis.in](http://www.standardsbis.in).

This Indian Standard has been developed from Doc No.: MED 16 (20154).

### Amendments Issued Since Publication

Amend No.	Date of Issue	Text Affected

## BUREAU OF INDIAN STANDARDS

### Headquarters:

Manak Bhavan, 9 Bahadur Shah Zafar Marg, New Delhi 110002

Telephones: 2323 0131, 2323 3375, 2323 9402

Website: [www.bis.gov.in](http://www.bis.gov.in)

### Regional Offices:

	Telephones
Central : 601/A, Konnectus Tower -1, 6 <sup>th</sup> Floor, DMRC Building, Bhavbhuti Marg, New Delhi 110002	{ 2323 7617
Eastern : 8 <sup>th</sup> Floor, Plot No 7/7 & 7/8, CP Block, Sector V, Salt Lake, Kolkata, West Bengal 700091	{ 2367 0012 2320 9474
Northern : Plot No. 4-A, Sector 27-B, Madhya Marg, Chandigarh 160019	{ 265 9930
Southern : C.I.T. Campus, IV Cross Road, Taramani, Chennai 600113	{ 2254 1442 2254 1216
Western : Plot No. E-9, Road No.-8, MIDC, Andheri (East), Mumbai 400093	{ 2821 8093

**Branches :** AHMEDABAD. BENGALURU. BHOPAL. BHUBANESHWAR. CHANDIGARH. CHENNAI. COIMBATORE. DEHRADUN. DELHI. FARIDABAD. GHAZIABAD. GUWAHATI. HIMACHAL PRADESH. HUBLI. HYDERABAD. JAIPUR. JAMMU & KASHMIR. JAMSHEDPUR. KOCHI. KOLKATA. LUCKNOW. MADURAI. MUMBAI. NAGPUR. NOIDA. PANIPAT. PATNA. PUNE. RAIPUR. RAJKOT. SURAT. VISAKHAPATNAM.