

भारतीय मानक
Indian Standard

IS 13558 (Part 5) : 2023
ISO 7752-5 : 2021

क्रेन — नियंत्रण अभिन्यास और विशेषताएँ
भाग 5 ब्रिज और गैन्ट्री क्रेन
(पहला पुनरीक्षण)

**Cranes — Control Layout and
Characteristics**
Part 5 Bridge and Gantry Crane
(*First Revision*)

ICS 53.020.20

© BIS 2023
© ISO 2021



भारतीय मानक ब्यूरो
BUREAU OF INDIAN STANDARDS
मानक भवन, 9 बहादुर शाह ज़फर मार्ग, नई दिल्ली - 110002
MANAK BHAVAN, 9 BAHADUR SHAH ZAFAR MARG
NEW DELHI - 110002
www.bis.gov.in www.standardsbis.in

November 2023

Price Group 8

NATIONAL FOREWORD

This Indian Standard (Part 5) (First Revision) which is identical to ISO 7752-5 : 2021 'Cranes — Control layout and characteristics — Part 5: Bridge and gantry cranes' issued by the International Organization for Standardization (ISO) was adopted by the Bureau of Indian Standards on the recommendations of the Cranes, Lifting Chains and Related Equipment Sectional Committee had been approved by the Mechanical Engineering Division Council.

This standard was first published in 1993. The first revision of this standard has been undertaken to align it with the latest version of ISO 7752-5 : 2021 'Cranes — Control layout and characteristics — Part 5: Bridge and gantry cranes'.

The text of the ISO standard has been approved for publication as Indian Standard without deviations. Certain terminologies and conventions are, however, not identical to those used in Indian Standards. Attention is particularly drawn to the following:

- a) Wherever the words 'International Standard' appear referring to this standard, they should be read as 'Indian Standard'; and
- b) Comma (,) has been used as a decimal marker while in Indian Standards, the current practice is to use a point (.) as a decimal marker.

In this adopted standard, the reference appears to certain International Standards for which Indian Standards also exist. The corresponding Indian Standards, which are to be substituted in their respective places, are listed below along with their degree of equivalence for the editions indicated:

<i>International Standard</i>	<i>Corresponding Indian Standard</i>	<i>Degree of Equivalence</i>
ISO 4306-1 : 2007 Cranes — Vocabulary — Part 1: General	IS 13473 (Part 1) : 2015/ISO 4306-1 : 2007 Cranes — Vocabulary: Part 1 General	Identical
ISO 7752-1 : 2010 Cranes — Control layout and characteristics — Part 1: General principles	IS 13558 (Part 1) : 2018/ISO 7752-1 : 2010 Cranes — Control layout and characteristics: Part 1 General principles (<i>first revision</i>)	Identical

The Committee has reviewed the provisions of the following International Standard referred in this adopted standard and has decided that it is acceptable for use in conjunction with this standard:

<i>International Standard</i>	<i>Title</i>
ISO 4306-5 : 2005	Cranes — Vocabulary — Part 5: Bridge and gantry cranes

For the purpose of deciding whether a particular requirement of this standard is complied with, the final value, observed or calculated, expressing the result of a test or analysis, shall be rounded off in accordance with IS 2 : 2022 'Rules for rounding off numerical values (*second revision*)'. The number of significant places retained in the rounded off value should be the same as that of the specified value in this standard.

Contents

Page

Introduction.....iv

1 Scope..... 1

2 Normative references..... 1

3 Terms and definitions..... 1

4 General requirements..... 1

Annex A (informative) Examples for basic control arrangement..... 2

Introduction

To reduce operator confusion or their incorrect control movement, this document unifies controls for certain types of cranes.

ISO 7752-1 establishes the general principles for all kinds of cranes.

Indian Standard

CRANES — CONTROL LAYOUT AND CHARACTERISTICS

PART 5 BRIDGE AND GANTRY CRANE

(First Revision)

1 Scope

This document establishes the arrangement, requirements and direction of movement of the basic controls for travelling, traversing, slewing, cab movement and load hoisting and lowering operations for all cab-operated, overhead travelling cranes and portal bridge cranes, as defined in ISO 4306-1 and ISO 4306-5.

2 Normative references

The following documents are referred to in the text in such a way that some or all of their content constitutes requirements of this document. For dated references, only the edition cited applies. For undated references, the latest edition of the referenced document (including any amendments) applies.

ISO 4306-1, *Cranes — Vocabulary — Part 1: General*

ISO 4306-5, *Cranes — Vocabulary — Part 5: Bridge and gantry cranes*

ISO 7752-1, *Cranes — Control layout and characteristics — Part 1: General principles*

3 Terms and definitions

For the purposes of this document, the terms and definitions given in ISO 4306-1, ISO 4306-5 and ISO 7752-1 apply.

ISO and IEC maintain terminological databases for use in standardization at the following addresses:

- ISO Online browsing platform: available at <https://www.iso.org/obp>
- IEC Electropedia: available at <https://www.electropedia.org/>

4 General requirements

The controls for the crane shall comply with ISO 7752-1.

NOTE [Annex A](#) provides examples of basic control arrangements.

Annex A (informative)

Examples for basic control arrangement

Cabin controls, remote control and radio control, when applicable, should be arranged around and in front of the operator as shown from [Figure A.1](#) to [Figure A.10](#).

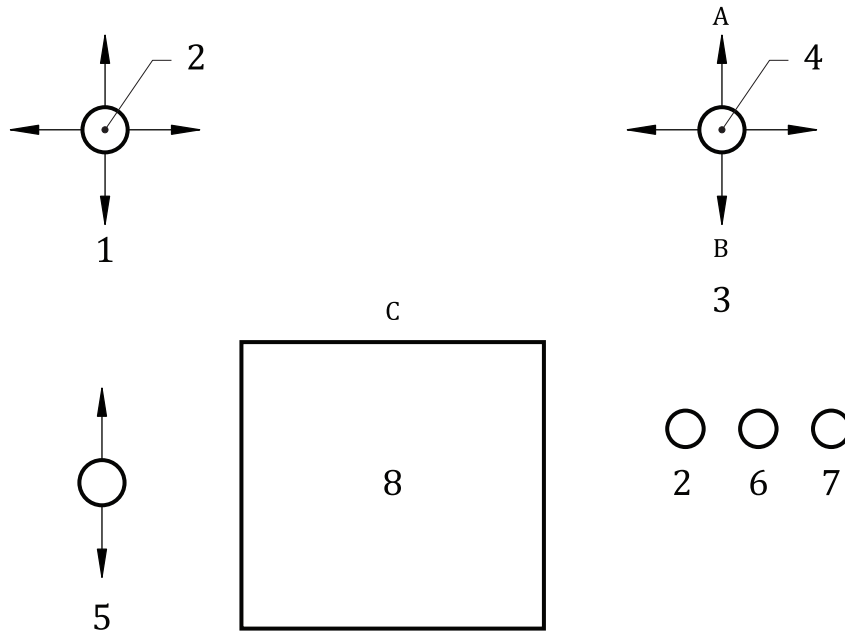

a) Overhead travelling crane, Portal bridge crane, semi-portal bridge crane

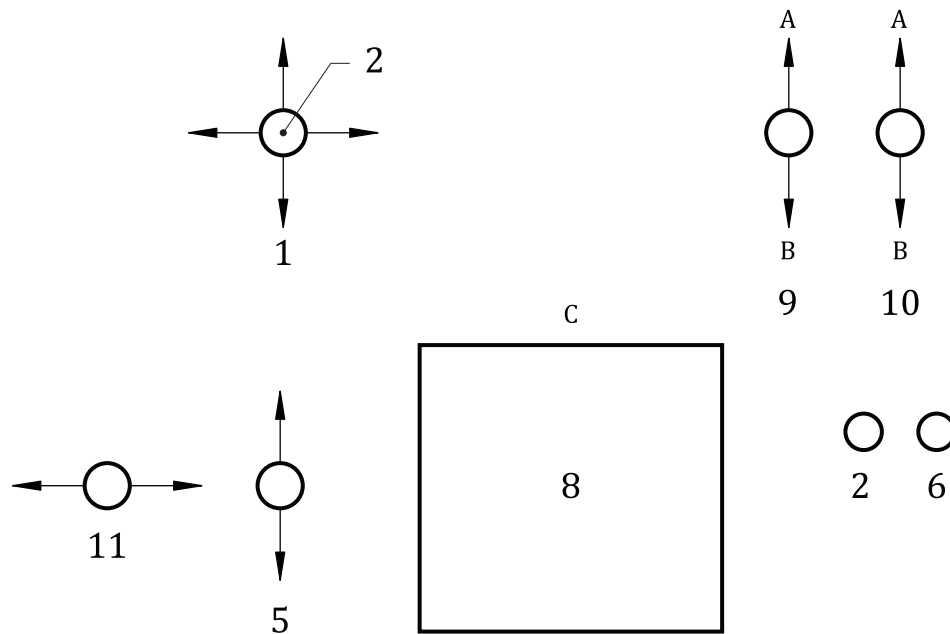

b) Overhead travelling crane, Portal bridge crane, semi-portal bridge crane with tilting hoist

Key

- 1 travelling and traversing [handle (joy stick) directions are the same as directions of movements]
- 2 alarm (in handle of joy stick, alternative locations)
- 3 main hoist and slewing [handle (joy stick) directions are the same as directions of movements]
- 4 radio 2 way (in handle of joy stick)
- 5 cab movement [handle (joy stick) directions are the same as directions of movements]
- 6 emergency stop
- 7 hoist selector where multiple hoists/trolleys are fitted
- 8 operator
- 9 main hoist
- 10 auxiliary hoist
- 11 slewing [handle (joy stick) directions are the same as directions of movements]
- A lower
- B raise
- C front

Figure A.1 — Basic control arrangement 1 a) and 1 b)

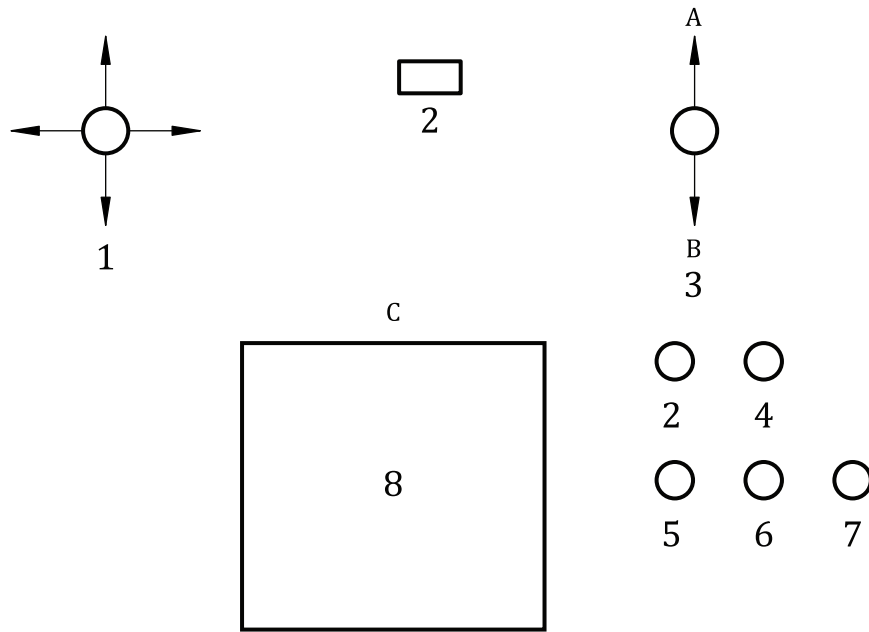

Key

- 1 travelling and traversing [handle (joy stick) directions are the same as directions of movements]
- 2 alarm (alternative locations)
- 3 hoist
- 4 emergency stop
- 5 boom up
- 6 boom stop
- 7 boom down
- 8 operator
- A lower
- B raise
- C front

Figure A.2 — Basic control arrangement 2 — Dual (Single) hoist ship-to-shore container crane

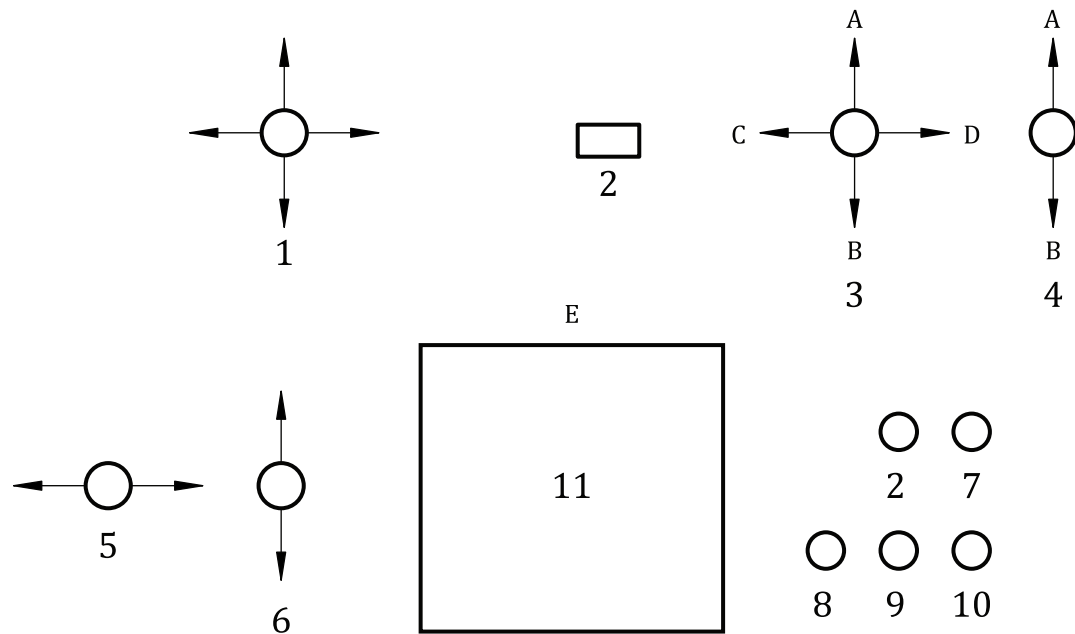

Key

- 1 travelling and traversing [handle (joy stick) directions are the same as directions of movements]
- 2 alarm (alternative locations)
- 3 main hoist
- 4 auxiliary hoist (optional)
- 5 slewing [handle (joy stick) directions are the same as directions of movements (optional)]
- 6 cab movement [handle (joy stick) directions are the same as directions of movements]
- 7 emergency stop
- 8 boom up
- 9 boom stop
- 10 boom down
- 11 operator
- A lower
- B raise
- C grab close (or other load-handling device function)
- D grab open
- E front

Figure A.3 — Basic control arrangement 3 — Bridge type grab ship unloader

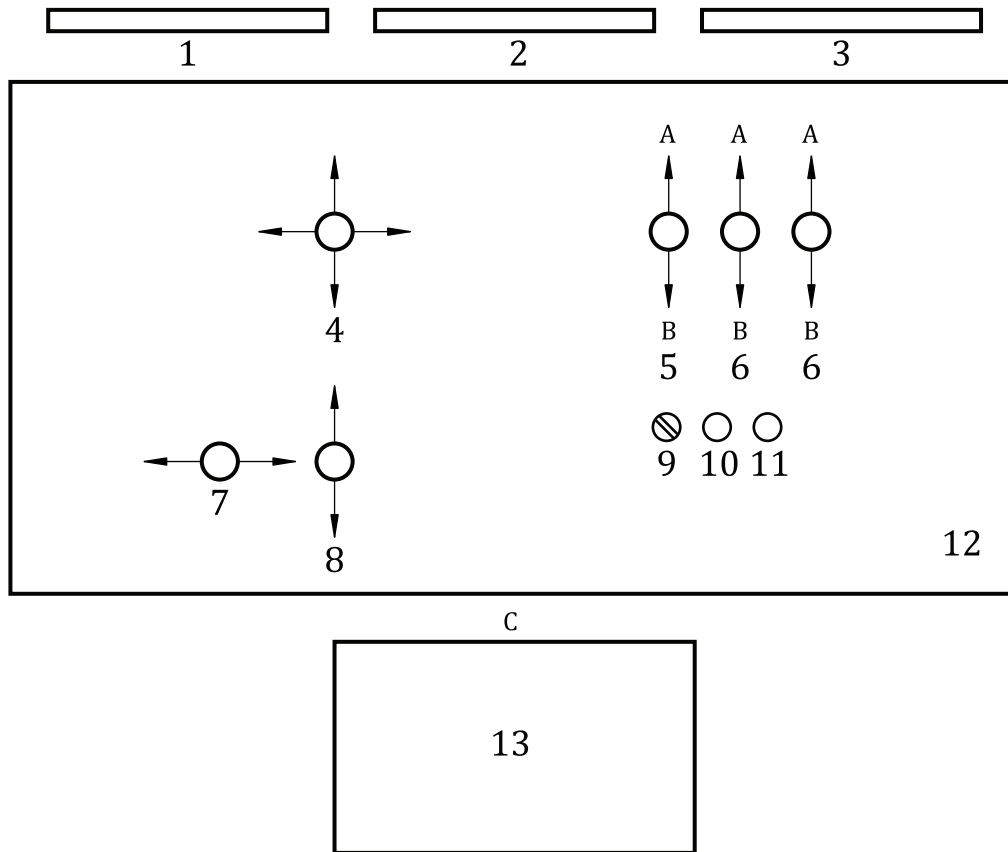

Key

- 1 crane management system (CMS)
- 2 video display (detail view)
- 3 video display (crane general view)
- 4 travelling and traversing
- 5 main hoist
- 6 auxiliary hoist (optional)
- 7 slewing [handle (joy stick) directions are the same as directions of movements (optional)]
- 8 cab movement [handle (joy stick) directions are the same as directions of movements]
- 9 auto/manual
- 10 alarm
- 11 emergency stop
- 12 desk
- 13 operator
- A lower
- B raise
- C front

Figure A.4 — Basic control arrangement 4 — Remote (overhead travelling crane, portal bridge crane, semi-portal bridge crane)

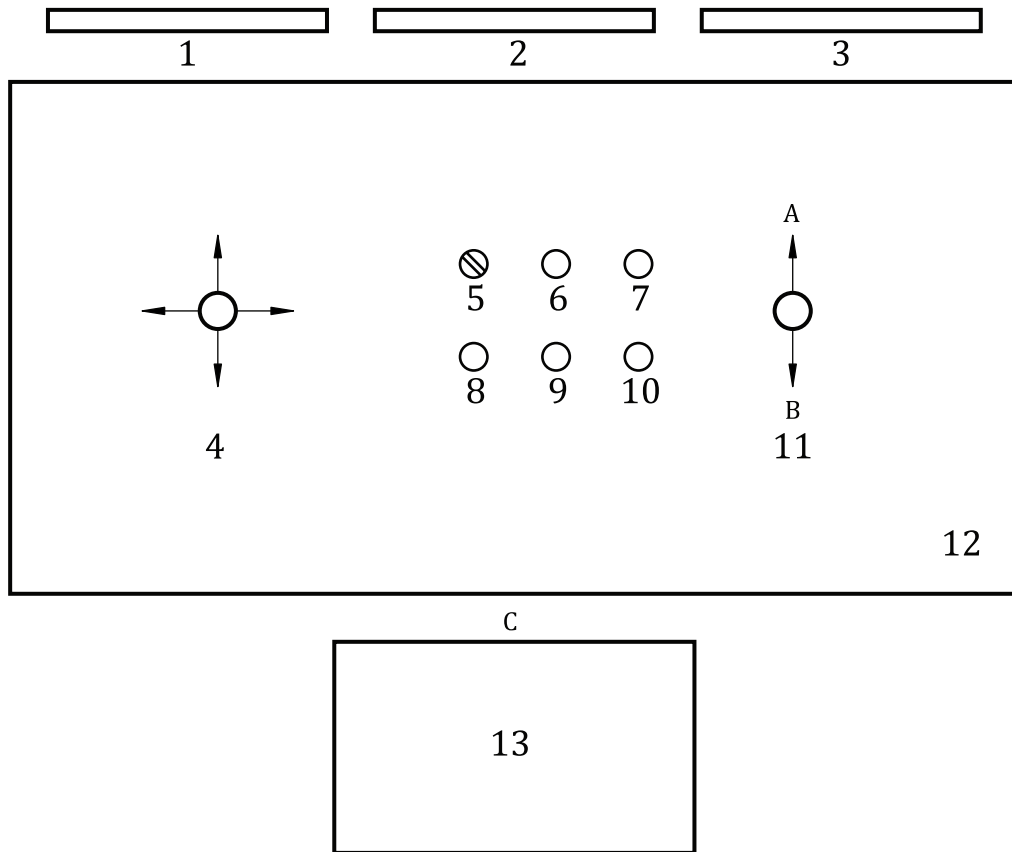

Key

- 1 crane management system (CMS)
- 2 video display (spreader twistlock view)
- 3 video display (crane general view)
- 4 travelling and traversing
- 5 auto/manual
- 6 alarm
- 7 emergency stop
- 8 boom up
- 9 boom stop
- 10 boom down
- 11 hoist
- 12 desk
- 13 operator
- A lower
- B raise
- C front

Figure A.5 — Basic control arrangement 5 — Remote [dual (single) hoist ship-to-shore container crane]

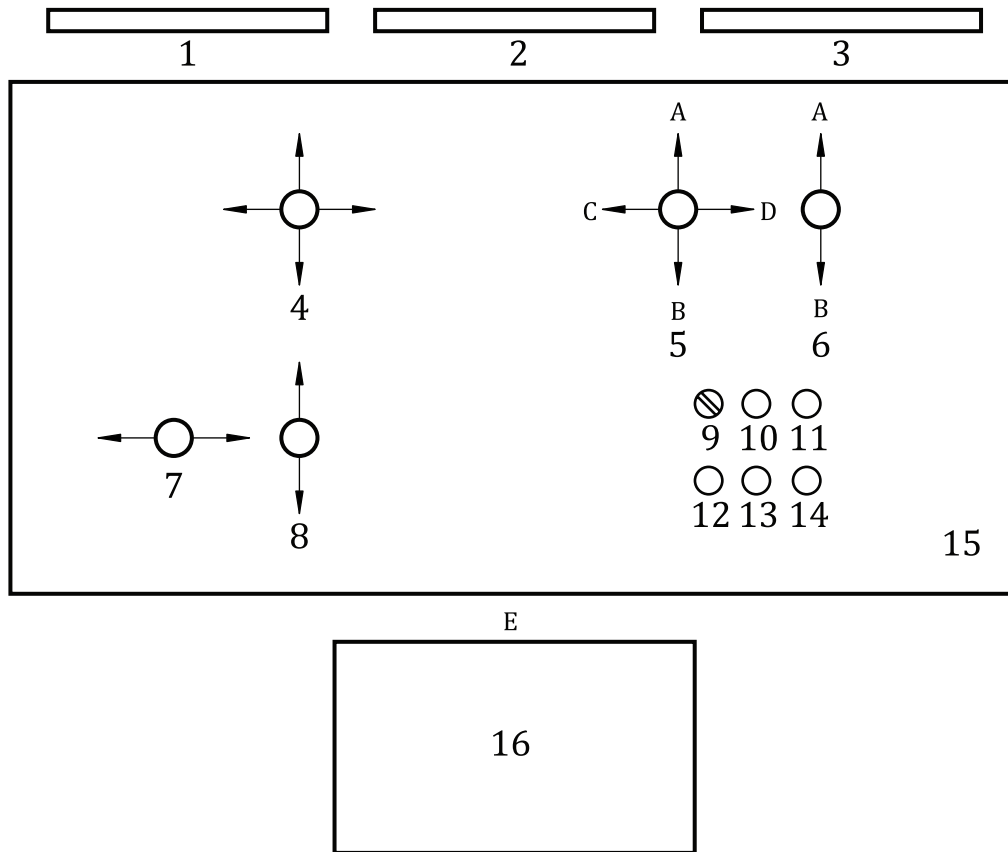

Key

- 1 crane management system (CMS)
- 2 video display (detail view)
- 3 video display (crane general view)
- 4 travelling and traversing
- 5 main hoist
- 6 auxiliary hoist (optional)
- 7 slewing [handle (joy stick) directions are the same as directions of movements (optional)]
- 8 cab movement [handle (joy stick) directions are the same as directions of movements]
- 9 auto/manual
- 10 alarm
- 11 emergency stop
- 12 boom up
- 13 boom stop
- 14 boom down
- 15 desk
- 16 operator
- A lower
- B raise
- C grab close (or other load handling device function)
- D grab open
- E front

Figure A.6 — Basic control arrangement 6 — Remote (bridge type grab ship unloader)

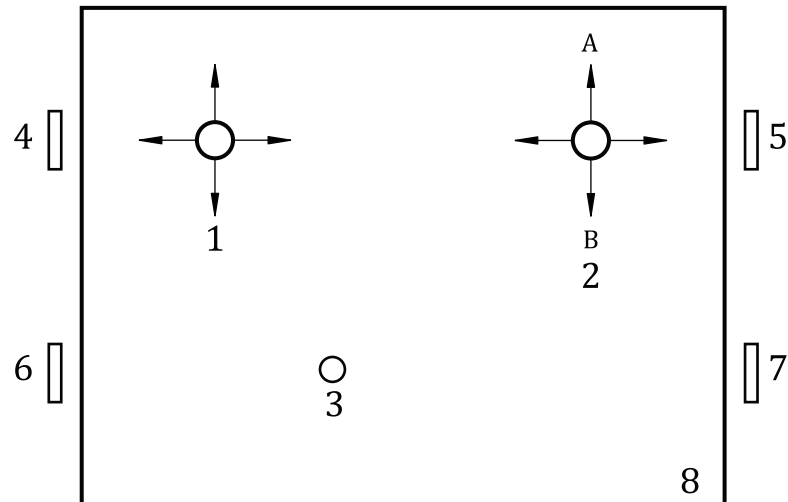

a) Radio (overhead travelling crane, portal bridge crane, semi-portal bridge crane)

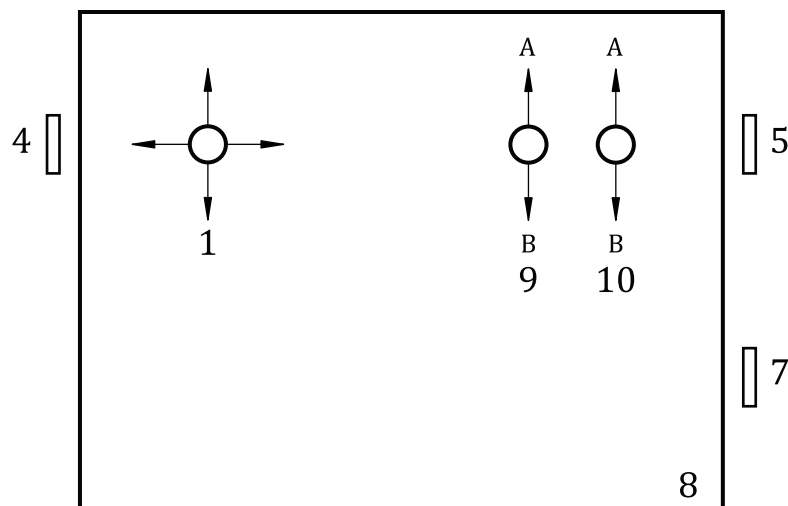

b) Radio (portal bridge crane, semi-portal bridge crane) with tilting hoist

Key

- 1 travelling and traversing
- 2 main hoist and slewing (or grab)
- 3 hoist selector (stay put) and hoist combination selector
- 4 alarm
- 5 start
- 6 additional (safety) grab open
- 7 emergency stop
- 8 radio control housing
- 9 main hoist
- 10 auxiliary hoist (tilting hoist)
- A lower
- B raise

Figure A.7 — Basic control arrangement 7 — Radio

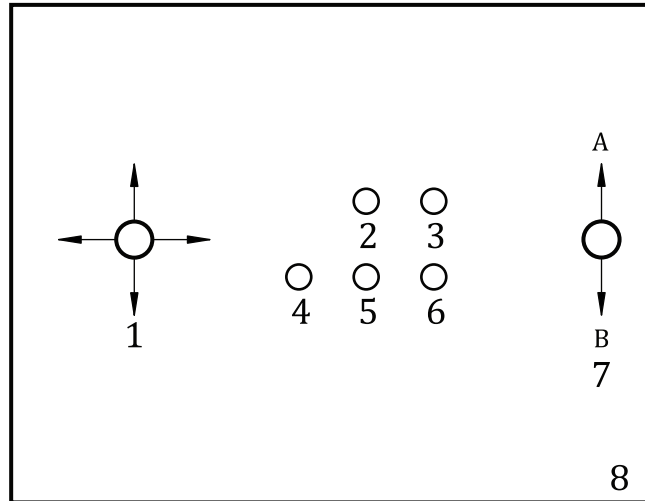

Key

- 1 travelling and traversing
- 2 alarm
- 3 emergency stop
- 4 boom up
- 5 boom stop
- 6 boom down
- 7 hoist
- 8 radio control housing
- A lower
- B raise

Figure A.8 — Basic control arrangement 8 — Radio [dual (single) hoist ship-to-shore container crane]

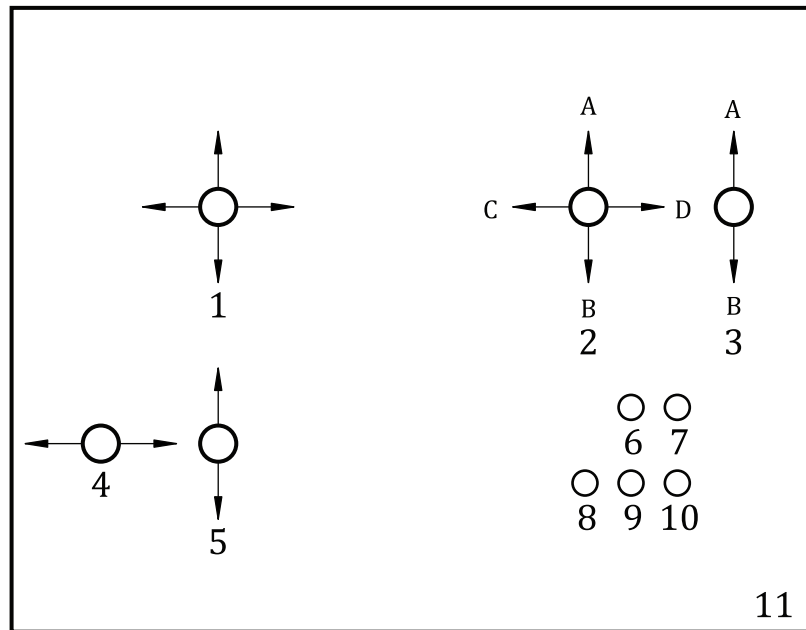

Key

- 1 travelling and traversing
- 2 main hoist
- 3 auxiliary hoist (optional)
- 4 slewing [handle (joy stick) directions are the same as directions of movements (optional)]
- 5 cab movement [handle (joy stick) directions are the same as directions of movements]
- 6 alarm
- 7 emergency stop
- 8 boom up
- 9 boom stop
- 10 boom down
- 11 radio control housing
- A lower
- B raise
- C grab close (or other load handling device function)
- D grab open

Figure A.9 — Basic control arrangement 9 — Radio (bridge type grab ship unloader)

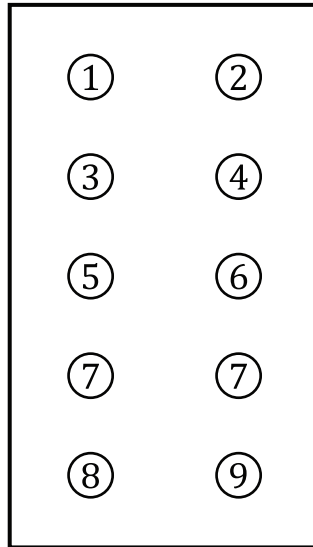

Key

- 1 lower
- 2 raise
- 3 left
- 4 right
- 5 forward
- 6 reverse
- 7 multi-function
- 8 start/alarm
- 9 emergency stop

Figure A.10 — Basic control arrangement 10 — Pendent style radio (remote) - bridge cranes

Bureau of Indian Standards

BIS is a statutory institution established under the *Bureau of Indian Standards Act, 2016* to promote harmonious development of the activities of standardization, marking and quality certification of goods and attending to connected matters in the country.

Copyright

BIS has the copyright of all its publications. No part of these publications may be reproduced in any form without the prior permission in writing of BIS. This does not preclude the free use, in the course of implementing the standard, of necessary details, such as symbols and sizes, type or grade designations. Enquiries relating to copyright be addressed to the Head (Publication & Sales), BIS.

Review of Indian Standards

Amendments are issued to standards as the need arises on the basis of comments. Standards are also reviewed periodically; a standard along with amendments is reaffirmed when such review indicates that no changes are needed; if the review indicates that changes are needed, it is taken up for revision. Users of Indian Standards should ascertain that they are in possession of the latest amendments or edition by referring to the website-www.bis.gov.in or www.standardsbis.in.

This Indian Standard has been developed from Doc No.: MED 14 (22074).

Amendments Issued Since Publication

Amend No.	Date of Issue	Text Affected

BUREAU OF INDIAN STANDARDS

Headquarters:

Manak Bhavan, 9 Bahadur Shah Zafar Marg, New Delhi 110002

Telephones: 2323 0131, 2323 3375, 2323 9402

Website: www.bis.gov.in

Regional Offices:

	Telephones
Central : 601/A, Konnectus Tower -1, 6 th Floor, DMRC Building, Bhavbhuti Marg, New Delhi 110002	{ 2323 7617
Eastern : 8 th Floor, Plot No 7/7 & 7/8, CP Block, Sector V, Salt Lake, Kolkata, West Bengal 700091	{ 2367 0012 2320 9474
Northern : Plot No. 4-A, Sector 27-B, Madhya Marg, Chandigarh 160019	{ 265 9930
Southern : C.I.T. Campus, IV Cross Road, Taramani, Chennai 600113	{ 2254 1442 2254 1216
Western : Plot No. E-9, Road No.-8, MIDC, Andheri (East), Mumbai 400093	{ 2821 8093

Branches : AHMEDABAD. BENGALURU. BHOPAL. BHUBANESHWAR. CHANDIGARH. CHENNAI. COIMBATORE. DEHRADUN. DELHI. FARIDABAD. GHAZIABAD. GUWAHATI. HIMACHAL PRADESH. HUBLI. HYDERABAD. JAIPUR. JAMMU & KASHMIR. JAMSHEDPUR. KOCHI. KOLKATA. LUCKNOW. MADURAI. MUMBAI. NAGPUR. NOIDA. PANIPAT. PATNA. PUNE. RAIPUR. RAJKOT. SURAT. VISAKHAPATNAM.