

सिविल इंजीनियरिंग प्रयोजनों (पॉलीमर लेपित जस्तीकृत इस्पात के तार या जस्तीकृत इस्पात के तार) के लिए मशीन से बुना हुआ, दोहरा ऐंठन की हुई, षटकोणीय जालीदार गेबियन, रीवेट के मैट्रेस, शैल पात जाल और अन्य उत्पाद —
विशिष्टि

(दूसरा पुनरीक्षण)

Mechanically Woven, Double-Twisted, Hexagonal Wire Mesh Gabions, Revet Mattresses, Rock Fall Netting and Other Products for Civil Engineering Purposes (Galvanized Steel Wire or Galvanized Steel Wire With Polymer Coating) — Specification

(Second Revision)

ICS 25.220.99; 77.140.65

© BIS 2024



भारतीय मानक ब्यूरो
BUREAU OF INDIAN STANDARDS
मानक भवन, 9 बहादुर शाह ज़फर मार्ग, नई दिल्ली - 110002
MANAK BHAVAN, 9 BAHADUR SHAH ZAFAR MARG
NEW DELHI - 110002
www.bis.gov.in www.standardsbis.in

FOREWORD

This Indian Standard (Second Revision) was adopted by the Bureau of Indian Standards, after the draft finalized by the Wire Ropes and Wire Products Sectional Committee had been approved by the Mechanical Engineering Division Council.

Gabions are widely used to protect the land from erosion, channel lining, construction of earth retaining structures, etc. It was, therefore, felt necessary to develop an Indian Standard on mechanically woven gabions due to large use of the item for hilly areas, river beds, forest area as well as near sea beds for protection of land and minimize land erosion. This standard also specifies the requirements forrevet mattresses, sack gabions, soil reinforcement facia units and rock fall netting. Based on their use, all the products may be galvanized with polymer coating therefore, those requirements have also been added in this standard.

There is a separate Indian Standard which lays down requirements for welded wire fabric gabions and gabion mattresses (metallic-coated or metallic-coated with PVC coating).

This standard was first published in 2012 and subsequently revised in 2018. This standard is being revised again to keep pace with the latest technological developments and international practices. Also, in this revision, the standard has been brought into latest style and format of Indian Standard, and references to Indian Standard wherever applicable has been updated. In this revision, the following major changes have been made:

- a) Polymer coating test [12.7](#) has been added;
- b) Provisions of Punch test in [12.2](#) has been widened;
- c) Certain terminology has been added in [3](#); and
- d) [Table 4](#) and [Table 5](#) has also been modified.

This standard does not intend to address all of the safety concerns associated with the use of gabions and gabion mattresses and other products. It is the responsibility of the manufacturers and users of this standard to establish and employ appropriate safety measures and also to ensure compliance to applicable regulations.

The composition of the Committee responsible for the formulation of this standard is given in [Annex C](#).

For the purpose of deciding whether a particular requirement of this standard is complied with the final value, observed or calculated, expressing the result of a test or analysis shall be rounded off in accordance with IS 2 : 2022 'Rules for rounding off numerical values (*second revision*)'. The number of significant places retained in the rounded-off value should be the same as that of the specified value in this standard.

Indian Standard

MECHANICALLY WOVEN, DOUBLE-TWISTED, HEXAGONAL WIRE MESH GABIONS, REVET MATTRESSES, ROCK FALL NETTING AND OTHER PRODUCTS FOR CIVIL ENGINEERING PURPOSES (GALVANIZED STEEL WIRE OR GALVANIZED STEEL WIRE WITH POLYMER COATING) — SPECIFICATION

(*Second Revision*)

1 SCOPE

This standard covers gabions, revet mattresses, sack gabions, soil reinforcement facia units and rockfall netting produced from double-twisted galvanized wire mesh, and galvanized wire for lacing wire, used for manufacturing, assembling, and installation of the product. This standard also covers gabions, revet mattresses, sack gabions, soil reinforcement facia units and rock fall netting in which the wire mesh and lacing wire are polymer-coated after the galvanizing. Double- twisted wire mesh for gabions, revet mattresses, sack gabions, soil reinforcement facia units and rockfall netting is produced in different classes based on type of coating.

2 REFERENCES

The standards listed in [Annex A](#) contain provisions which, through reference in this text, constitute provisions of this standard. At the time of publication, the editions indicated were valid. All standards are subject to revision, and parties to agreements based on this standard are encouraged to investigate the possibility of applying the most recent edition of these standards.

3 TERMINOLOGY

For the purpose of this standard, following definitions shall apply.

3.1 Gabion — A wire mesh container of variable sizes, uniformly partitioned into internal cells, interconnected with other similar units, and filled with stone at the project site to form flexible, permeable monolithic structures for earth retaining and erosion control purposes, such as retaining walls, sea walls, channel linings, revetments, offshore bunds, dykes and weirs (see [Fig. 1](#) to [Fig. 5](#)).

3.1.1 Strong Face Gabion — A gabion unit as described in [3.1](#) with the front or/and one side of gabion is produced with mesh wire diameter of ≥ 3.4 mm (≥ 4 mm outer dia in case it is polymer coated) and other sides of gabion are produced with mesh of wire diameter ≥ 2.7 mm (3.7 mm in case it

is polymer coated) in order to obtain higher abrasion resistance and improve front face strength and are used for retaining walls, river works, erosion control, noise barriers, and architectural works.

3.2 Revet Mattress — Revet mattress is a wire mesh container uniformly partitioned into internal cells with relatively smaller height in relation to other dimensions, having smaller mesh openings than the mesh used for gabions, revet mattresses are generally used for riverbank protection and channel linings (see [Fig. 6](#)). These revet mattress can have double wall partitions and additional vertical ties to enhance its protection performance further.

In case of usage in situations where stone fill is not available, the revet mattress may be lined with geotextile and filled with soil. In this case the covering lid of the revet mattress may be of erosion control mat to allow for vegetation growth.

3.3 Rock Fall Netting — A wire mesh supplied in the form of rolls with or without inserted steel wire ropes in the longitudinal direction or longitudinal and transverse directions which is used to prevent rocks and debris from falling onto roads, railways or any other area which needs protection (see [Fig. 7](#)).

3.4 Sack Gabions — A cylindrical double-twist steel wire mesh unit with a lateral opening to allow the stone filling or geotextile encased sand filling at the site. (see [Fig. 8](#)).

3.5 Soil Reinforcement Units for Retaining Structures — Double twisted steel wire mesh units used for reinforced soil structures and slope consolidation.

3.5.1 For structures with vertical facing (see [Fig. 9](#)), units are made with hexagonal wire mesh continuous base panel for the reinforcement and the facing portion of the structure.

3.5.2 For the structures with inclined vegetative facing (see [Fig. 10\(a\)](#)), units are made with

hexagonal wire mesh continuous base reinforcement, provided (or made) with a welded mesh panel for facing, a geotextile for soil retention and metallic ties for installation procedures.

3.5.2.1 For the structures with steeply inclined stone facing [see Fig. 10 (b)] units are made with hexagonal wire mesh continuous base reinforcement, provided (or made) with a welded mesh panel for facing, and metallic ties for installation procedures.

3.6 Pavement reinforcement mesh — A bi-directional bound layer reinforcement made of double-twist hexagonal wire mesh with transverse steel rod woven it mesh at regular intervals typically used for road maintenance and new road construction works (see Fig. 12).

3.7 Double-Twisted Wire Mesh — A non-raveling mesh made by twisting continuous pairs of wires through three one-half turns (commonly called double-twisted) to form hexagonal-shaped openings which are then interconnected to adjacent wires to form hexagonal openings. The double-twisted wire mesh may be combined with erosion control mats as a reinforcement to provide tensile strength to the erosion control mat.

3.8 Selvedge Wire — A terminal wire used to edge the wire mesh perpendicular to the double twist by mechanically wrapping the mesh wires around it at least 2.5 times (see Fig. 1).

3.9 Edge Wire — A terminal wire of the same

diameter as the selvedge wire used to edge the wire mesh parallel to the double twist by continuously weaving it mechanically into the wire mesh (see Fig. 1).

3.10 Lacing Wire — A galvanized wire or galvanized wire with polymer coating used to assemble and interconnect empty units, to close and secure stone-filled units, and for internal stiffeners (see Fig. 2 and Fig. 3).

3.11 Spenax Fasteners/Overlapping Fasteners/Steel Rings — A galvanized or stainless-steel ring which is used instead of, or to compliment lacing wire for basket assembly and installation (see Fig. 4).

3.12 Diaphragm — An internal partition made of same wire mesh panel in a gabion/revet mattress/sack gabion and soil reinforcement facia units that is attached to the bottom, the sides, and, after the units are packed with stones, to the lid of the cage (see Fig. 5).

3.13 Bracing Wire/Stiffener — A length of galvanized wire or galvanized wire with polymer coating used for support of facing by connecting the front panel to the back panel of a gabion and having the same diameter as the lacing wire (see Fig. 11).

3.14 Mesh Size — The average distance measured at right angles between twisted sides over ten meshes (see Fig. 13).

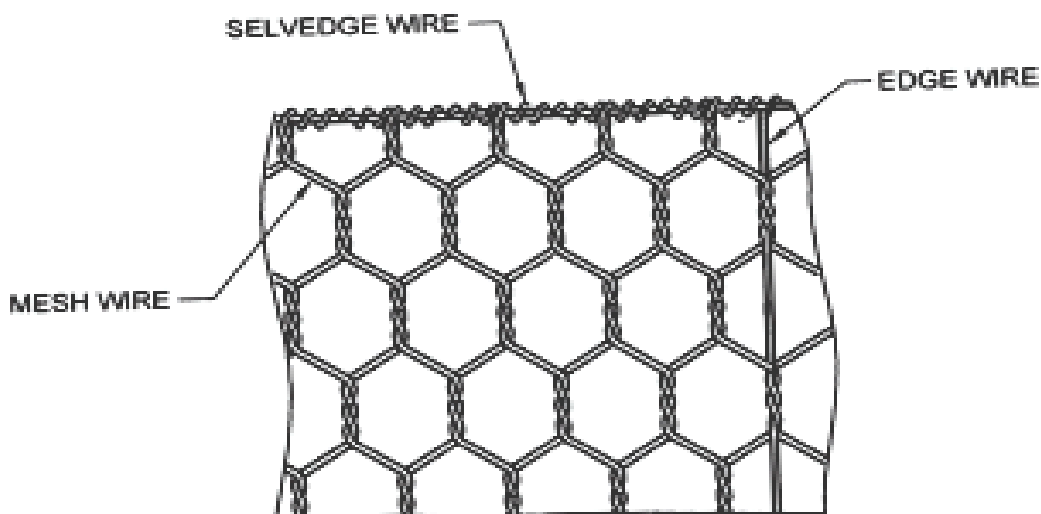

FIG. 1 MESH WIRE, SELVEDGE AND EDGE WIRE

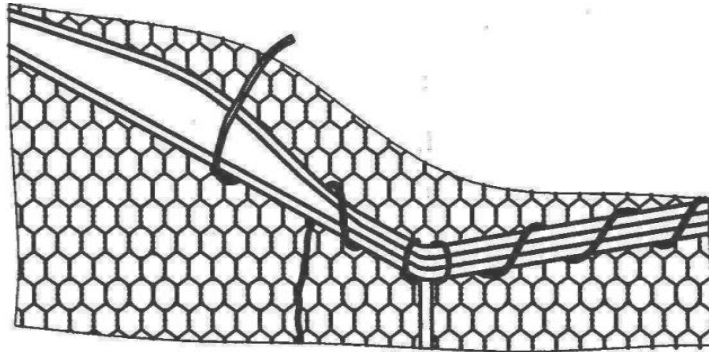

FIG. 2 LACING WIRE FOR TYING

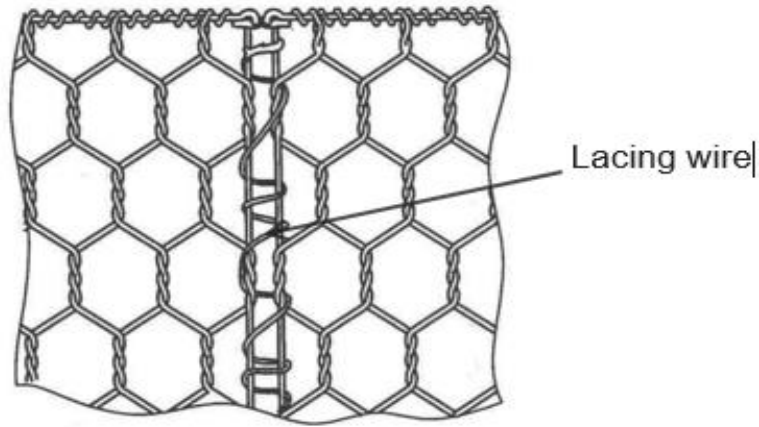

FIG. 3 LACING WIRE FOR TYING ADJACENT PANELS IN SINGLE AND DOUBLE LOOP FASHION

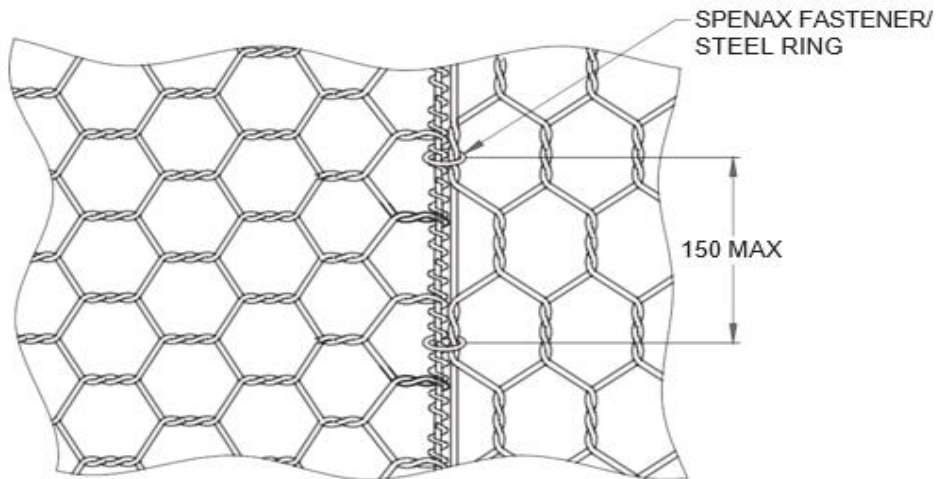

FIG. 4 RINGS FOR JOINING ADJACENT PANELS INSTEAD OR WITH LACING WIRE

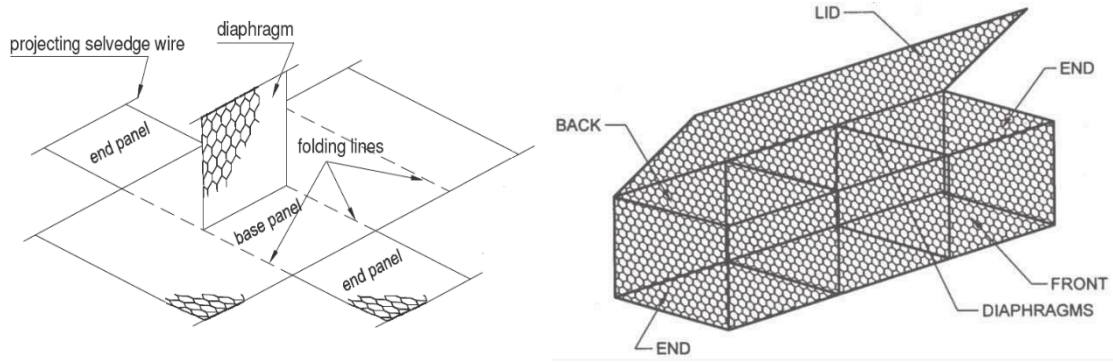

FIG. 5 GABION BOX

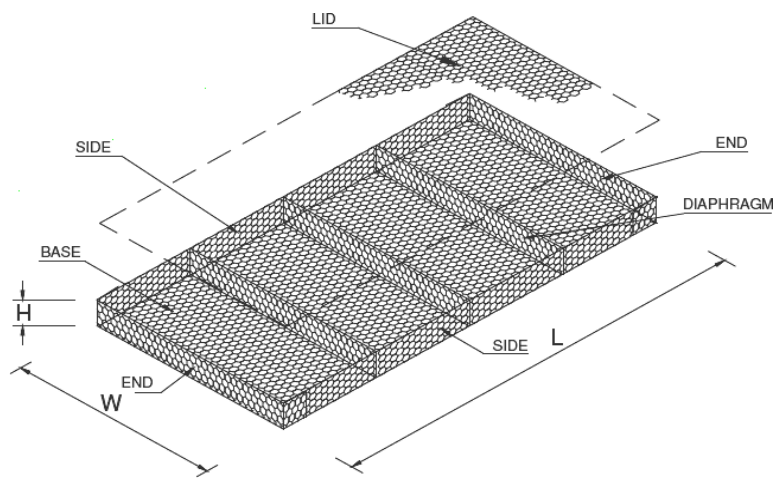

FIG. 6 REVET MATTRESS

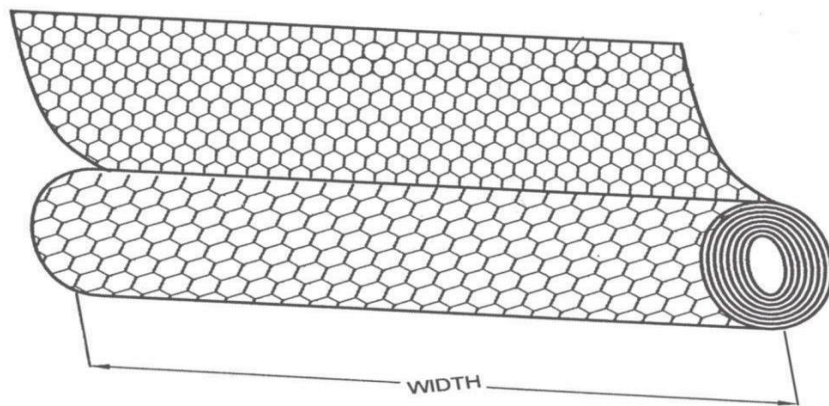
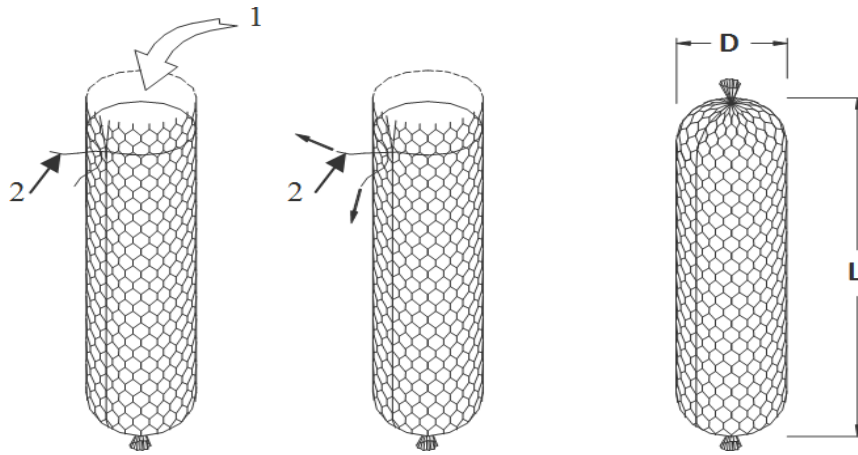

FIG. 7 ROCKFALL NETTING



Key

- 1 filling
- 2 lacing wire
- D diameter of the sack gabions
- L length of the sack gabions

FIG. 8 SACK GABION

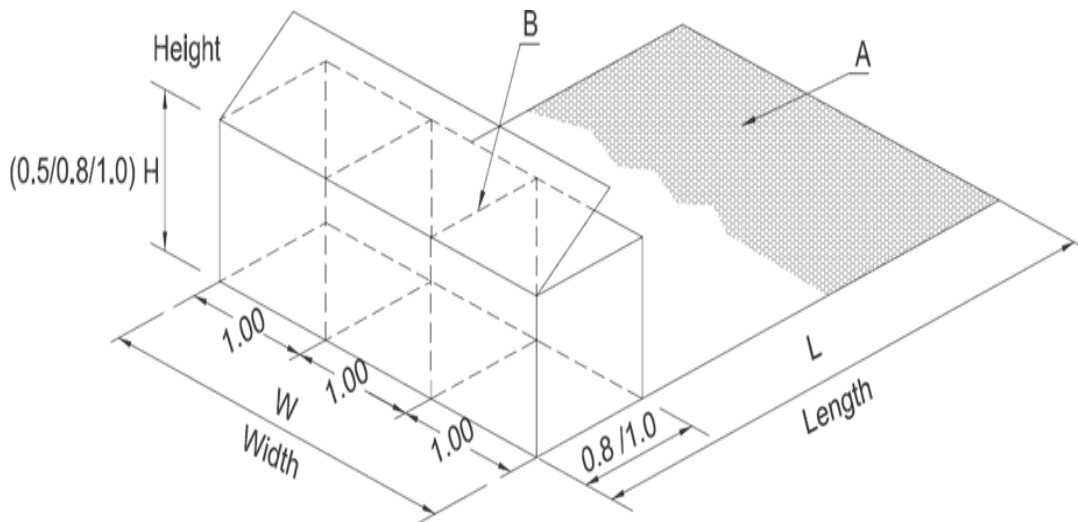

Key

- A base panel
- B diaphragm
- H height
- L length
- W width

FIG. 9 FACIA UNITS FOR VERTICAL FACING REINFORCED SOIL STRUCTURES

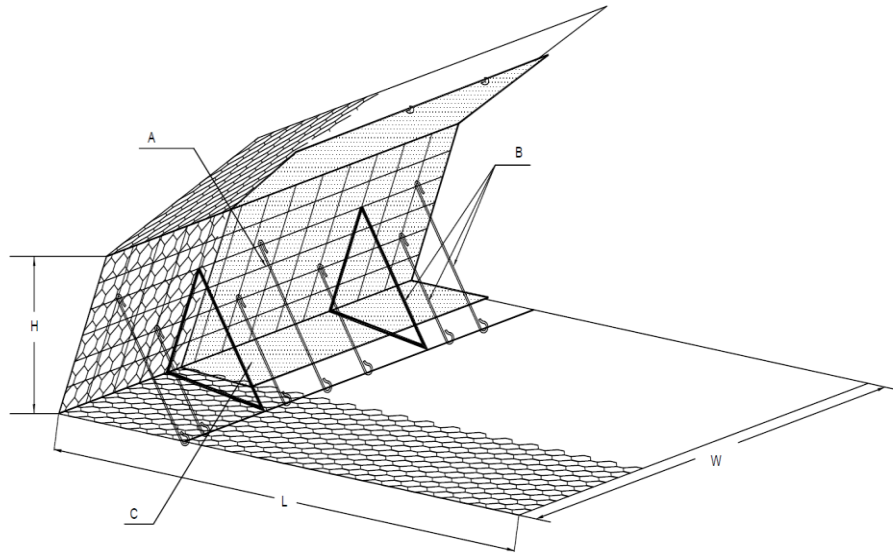

(a)

Key

- A welded panel
- B brackets/tie rods
- C geotextile
- H height
- L length
- W width
- α variable between 20° and 45°

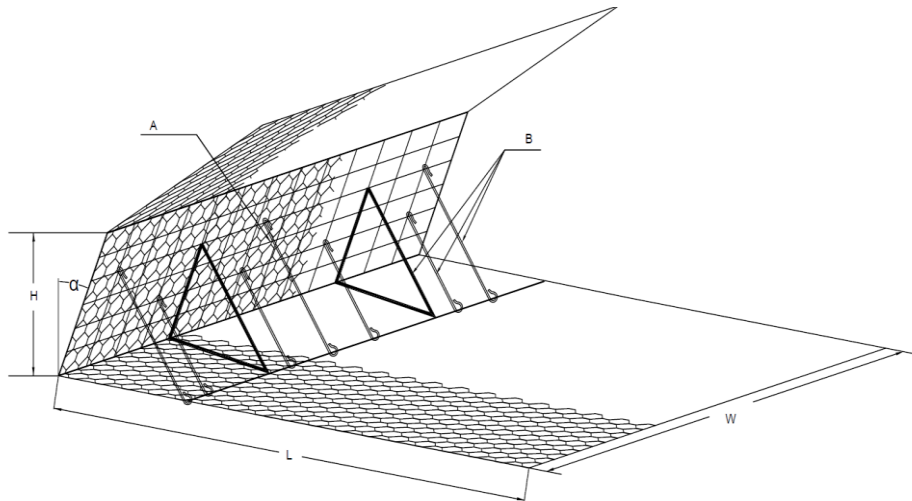

(b)

Key

- A welded panel
- B brackets/tie rods
- H height
- L length
- W width
- α variable between 3° and 25°

FIG. 10 (A) AND (B) FACIA UNITS FOR INCLINED FACING REINFORCED SOIL STRUCTURES

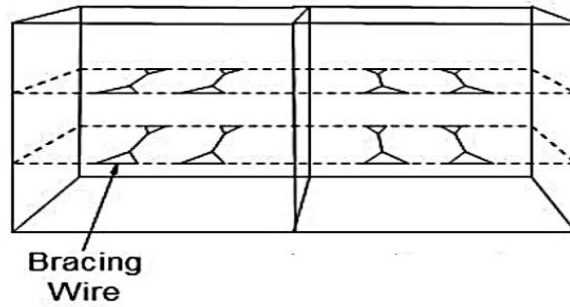

FIG. 11 BRACING WIRE/STIFFNER

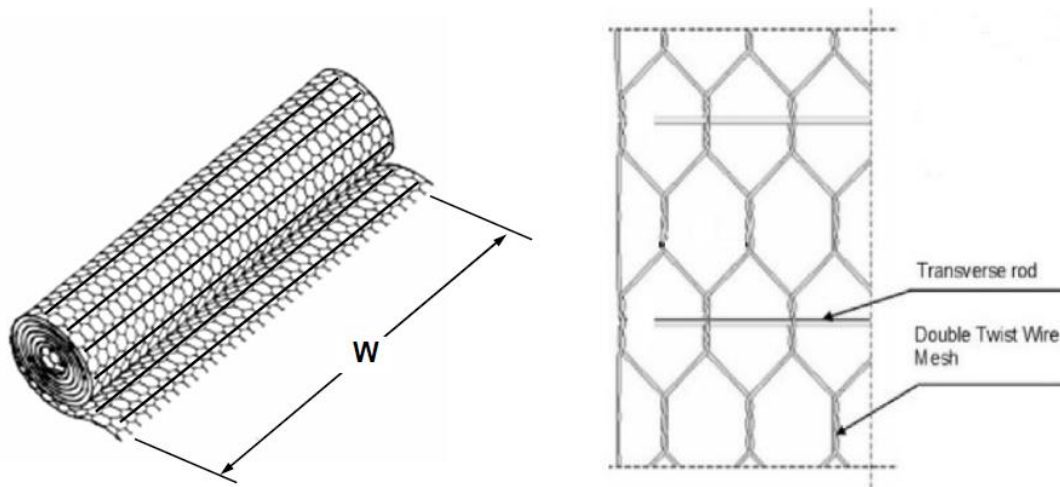

FIG. 12 PAVEMENT REINFORCEMENT MESH

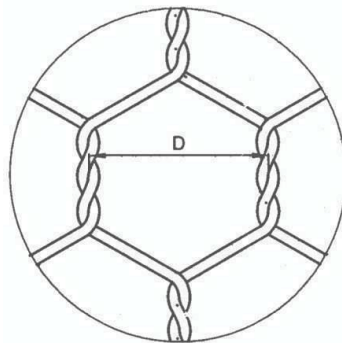

FIG. 13 MESH TYPE AND NOMINAL MESH SIZE (D)

4 CLASSIFICATIONS

Double-twisted wire mesh gabions, revet mattresses, rock fall netting, sack gabion and facia units of reinforced soil structures are classified according to coating, as follows:

- a) Class 1 — Consists of a double-twisted wire mesh made from wire which is zinc or zinc alloy coated before being double-twisted into mesh. Fasteners, lacing wire and stiffeners are produced from zinc or

zinc alloy-coated wire; and

- b) Class 2 — Consists of double-twisted wire mesh, lacing wire and stiffeners as Class 1 and overcoated with polymer (PVC/PA6/ other advanced polymers). The fastener shall be of stainless steel wire.

Refer [Annex B](#) for the description of the environment of installation site, and coating wire

requirements for different types of galvanization and polymeric coatings.

5 MATERIALS AND MANUFACTURE

5.1 The wire used in the manufacture of double-twisted mesh for use in gabions, revet mattresses, rock fall netting, sack gabions and facia units of reinforced soil structures shall conform to IS 280 and to the requirement of [5.1.1](#) or [5.1.2](#) as appropriate for the class ordered except that the tensile strength shall conform to [6.1](#).

5.1.1 Class 1 double-twisted mesh shall be manufactured from zinc or zinc alloy coated steel wire conforming to IS 4826, heavily coated and soft type or IS 12753 (heavy coated).

5.1.2 Class 2 double-twisted mesh shall be manufactured from the same type of galvanized steel wire as Class 1 with an additional polymer coating extruded onto the galvanized steel wire. The polymer coating shall conform to the requirements given in [7.2](#).

5.2 Gabions, revet mattresses, sack gabions and facia units of reinforced soil structure shall be manufactured with all components mechanically connected at the production facility with the exception of the mattress lid which is produced separately from the base. All gabions, revet mattresses, rock fall netting, sack gabions and facia units of reinforced soil structure shall be supplied in the collapsed form, either folded and bundled or rolled for shipping.

5.3 Lacing wire and stiffeners shall be made of wire having the same coating material as the double-twisted wire mesh furnished on the order and conforming to IS 4826 or IS 12753 (heavy coated) and tensile strength conforming to [6.1](#).

5.4 The spacing of the steel rings to compliment lacing wire during all phases of assembly and installation shall be in accordance with spacing based on pull-apart resistance for mesh when tested in accordance with [12.3](#) with a nominal spacing of 100 mm and not to exceed 150 mm.

5.4.1 Galvanized Rings

Fasteners made from galvanized steel wire of 3 mm diameter shall be used for products of Class 1 type mesh (see [Table 9](#)). The galvanized steel wire for fastener shall conform to SM Grade of IS 4454 (Part 1) with minimum tensile strength of 1 550 MPa and shall be galvanized with mass of zinc coating not less than that given in [Table 8](#).

5.4.2 Stainless Steel Fasteners

Fasteners made from stainless steel wire of 3 mm

diameter shall be used for products of Class 2 type mesh. The stainless steel wire for fastener shall conform to Grade 1 steel of IS 4454 (Part 4) with a minimum tensile strength of 1 550 MPa.

5.5 The standard sizes of gabion boxes, revet mattresses, sack gabions and facia units of reinforced soil rock fall netting are given in [Table 1](#), [Table 2](#), [Table 3](#), [Table 4](#), [Table 5](#) and [Table 6](#) respectively. Any other size as agreed to between the purchaser and the manufacturer.

6 MECHANICAL PROPERTIES

6.1 Tensile Strength

The tensile strength of wire used for double-twisted mesh, lacing wire, and stiffener, when tested shall be in accordance with the requirements of IS 280 for soft wire (350 Mpa to 550 MPa) at a minimum elongation of 10 percent, performed on a gauge length of test specimen as 200 mm.

6.2 Mesh Panel Strength

The minimum strength requirements of the mesh, when tested in accordance with [12.1](#), shall be as shown in [Table 7](#). When the mesh is provided with organic coating, a sample shall be tested (According to [12.1](#)) at 50 percent of nominal tensile strength without showing cracks in the organic coating within the double twist region.

7 PHYSICAL PROPERTIES

7.1 Zinc/Zinc Alloy Coating

7.1.1 Mass of Zinc/Zinc Alloy Coating

The coating mass shall conform to the requirements of IS 4826 heavily coated and soft type. The zinc alloy shall consist of 90 percent Zinc + 10 percent Aluminium (or) 95 percent Zinc + 5 percent Aluminium. (see [Table 8](#)) for the minimum mass of zinc/zinc alloy coating for different wire sizes.

7.1.2 Adhesion of Zinc/Zinc Alloy Coating

The Zinc/Zinc Alloy coating shall remain adherent to the steel wire and conform to IS 4826 such that zinc/zinc alloy coating does not flake off, nor crack to such an extent that there is possibility of removing any zinc/zinc alloy by rubbing with bare fingers, the use of finger nails being not allowed.

7.1.3 Ageing and Corrosion Resistance

- a) 95 percent Zn + 5 percent Al

When subjected to test in sulphur dioxide environment according to procedures in ISO 22479 after 28 cycles of discontinuous test, the test samples shall not show more than 5 percent of DBR (dark brown rust); and

- b) 90 percent Zn + 10 percent Al

When subjected to test in sulphur dioxide environment according to procedures in ISO 22479 after 56 cycles of discontinuous test, the test samples shall not show more than 5 percent of DBR (dark brown rust).

7.2 Polymer for Coating

The initial properties of polymer coating material shall conform to the following requirements:

- a) Specific gravity — In the range from 1.30 to 1.35 when tested in accordance with IS 13360 (Part 3/Sec 10, 11 and 12);
- b) Tensile strength — Not less than 20.6 MPa when tested in accordance with IS 13360 (Part 5/Sec 1);
- c) Hardness — Shore 'D' between 50 and 60, when tested in accordance with IS 13360 (Part 5/Sec 11);
- d) Resistance of polymer coating to sodium chloride solution — When polymer coated wire is tested in accordance with [12.4](#) there shall be no loss of mass;
- e) Salt spray exposure — The PVC shall be subjected to 3 000 h of salt spray exposure in accordance with IS 13360 (Part 8/Sec 14). After the salt spray test, the PVC Coating shall not show cracks nor noticeable change of colour, or blisters or splits. In addition, the specific gravity and tensile strength shall not change more than 6 percent and 25 percent respectively from their initial values;
- f) Modulus of Elasticity — Not less than 18.6 MPa [2 700 psi] when tested in accordance with test methods ISO 37; and
- g) Brittleness Temperature — Not higher than -9°C or lower temperature when specified by the purchaser, when tested in accordance with test method ISO 974 (*see* [Note](#)).

Applicability of this note needs to be checked based on ISO 974.

NOTE — The maximum brittleness temperature should be at least 8°C below the minimum temperature at which the gabions will be filled.

- h) Resistance to UV rays — Polymer mechanical characteristics (elongation and tensile strength) of the base compound after a UV rays exposure of 2 500 h QUV-A (ISO 4892-3 exposure mode 1)

cannot change more than 25 percent from the initial tests.

8 DIMENSIONS AND TOLERANCES

8.1 The diameter of galvanized steel wire shall conform to the values as per [Table 1](#) for gabions, [Table 2](#) for revet mattresses, [Table 3](#) for sack gabions, [Table 4](#) for vertical facing units of reinforced soil structures, [Table 5](#) for inclined facing units of reinforced soil structure and [Table 6](#) for rock fall netting. The diameter of the wires shall also conform to the tolerance values as shown in col (4) of [Table 5](#) as per IS 280 for galvanized steel wire.

8.2 The minimum and nominal thickness of polymer coating uniformly applied in a quality workmanlike manner shall be as shown in [Table 1](#), [Table 2](#), [Table 3](#), [Table 4](#), [Table 5](#) and [Table 6](#).

8.3 Gabions shall be manufactured with a 10×12 or 8×10 mesh type (*see* [Fig. 5](#)) having a nominal mesh opening size as per [Table 9](#). Dimensions are measured at right angles to the centre axis of the opening and parallel to the twist along the same axis.

8.4 Revet mattresses shall be manufactured with a 6×8 mesh type (*see* [Fig. 6](#)) having a nominal mesh opening size as per [Table 9](#). Dimensions are measured at right angles to the centre axis of the opening and parallel to the twist along the same axis.

8.5 Rock fall netting shall be manufactured with a 10×12 , 8×10 or 6×8 mesh type (*see* [Fig. 7](#)) having a nominal mesh opening size as per [Table 9](#).

8.6 Sack Gabion shall be manufactured with a 10×12 , 8×10 mesh type (*see* [Fig. 8](#)) having a nominal mesh opening size as per [Table 9](#).

8.7 Vertical facing units of reinforced soil structure shall be manufactured with a 10×12 , 8×10 mesh type (*see* [Fig. 9](#)) having a nominal mesh opening size as per [Table 9](#).

8.8 Inclined facing units of reinforced soil structure shall be manufactured with a 10×12 , 8×10 mesh type (*see* [Fig. 10](#)) having a nominal mesh opening size as per [Table 9](#).

8.9 The width and length of the gabions, revet mattresses, sack gabions, vertical and inclined facing units of reinforced soil structure as manufactured shall not differ more than ± 5 percent from the ordered size prior to filling. (Typical gabions, revet mattresses, sack gabions, vertical and inclined facing units of reinforced soil structure sizes are shown in [Table 1](#), [Table 2](#), [Table 3](#), [Table 4](#), and [Table 5](#) respectively.)

8.10 The height of the gabions, revet mattresses, sack gabions, vertical and inclined facing units of

reinforced soil structure as manufactured shall not differ more than + 10 percent, if the height is less than or equal to 0.3 m and shall not differ more than ± 5 percent if the height is more than 0.3 m from the ordered size prior to filling.

8.11 The tolerance on the roll length of rock fall netting shall be +1 m to 0 m. The tolerance on the width shall be $\pm D$ (mesh size). Also see [Table 6](#) for the typical sizes of netting rolls.

8.12 Mesh Opening Tolerances

Tolerances on the hexagonal, double-twisted wire mesh opening shall not exceed + 10 percent to - 10 percent on the nominal dimension D values mentioned in [Table 9](#).

9 WORKMANSHIP

Wire of proper grade and quality, when fabricated in the manner herein required, shall result in a strong, serviceable mesh type product have substantially uniform openings. It shall be fabricated and finished with good workmanship as determined by visual inspection and shall conform to this standard.

10 SAMPLING

10.1 Samples for determining the mechanical and physical properties of double-twisted wire mesh shall be in accordance with the samples, dimensions, and requirements described in [12](#).

10.2 Samples for determining the mechanical and physical properties of coated steel wire used for mesh, lacing wire and stiffeners shall be selected at random from wire coils used for manufacturing.

11 NUMBER OF TESTS

11.1 The tensile strength, galvanizing weight, and polymer coating thickness of the coated steel wire used in the fabrication of mesh, lacing wire and stiffeners shall be certified by the steel wire/Polymer coated steel wire producers for conformance to the requirements of [6](#), [7](#) and [8](#).

11.2 A minimum of three tests each for conformance to strength of galvanized steel wire mesh parallel to twist and perpendicular to twist shall be performed. A retest for conformance with the aforementioned strength tests shall be required when changes of the physical characteristics of the mesh products occur.

For galvanized steel wire with polymer coating, follow the same requirements as for the galvanized steel wire mesh. The results of all three tests shall meet the requirements of [Table 7](#).

12 TEST METHODS

12.1 Tensile Strength of Wire Mesh Panel

The wire mesh specimens shall be representative of

proper field construction as to materials, mesh geometry, and workmanship, and shall be as large as practical to minimize the effect of variations. The tests shall be run with the load applied parallel to the axis of the twist and repeated on a separate test specimen with the load applied perpendicular to the axis of the twist.

12.1.1 Place the mesh into the machine grips such that the gripped mesh will be maintained in the mesh geometry characteristic of field use. The specimen of approximately 0.8 m width and 0.5 m height shall be tested. The effective width to be considered for test specimen shall be the distance between two extreme gripping points. The specimen should extend by at least one mesh repetition beyond the extreme gripping points on either side. However, specimen should not extend more than two mesh repetitions beyond extreme gripping points. The mesh shall be pre-loaded to 10 percent of the specified minimum strength and machine head travels topped. The mesh gauge dimensions shall be recorded at this time and taken as the initial dimensions of the specimen where such dimensions are required. The loading shall then continue uniformly maintaining the displacement rate of 75 mm/min to 100 mm/min, until first fracture or unwrapping of an individual wire in the system occurs. The distortion of the mesh or changes in gauge length shall be measured to accuracy consistent with reporting the percent elongation to the nearest 0.5 percent.

12.2 Punch Test

The punch test could be done using two different apparatus.

a) Pretensioned punch test

An uncut section of 1.82m in length (unservedged) and not less than 0.91 m in width shall have the ends securely for 0.91 m along the width of the sample. When the width of the section under test exceeds 0.91m, the clamps shall be centered along the width and the excess width will be allowed to fall free on each side of the clamped section. The sample shall then be subjected to tension sufficient to cause 10 percent elongation of the same section between the clamps. After elongation and while clamped as described above (and otherwise unsupported), the section shall be subjected to a load over 960 cm² of area applied to the approximate center of the sample section between the clamps and in a direction perpendicular to the direction of the tension force.

b) Secured Punch Test

An uncut section of 1.24 m in length and not less than 0.9 m in width (selvedged), including all selvedge bindings, shall have the sides and the ends securely clamped at every mesh opening to a rigid frame. After being secured as described above, the section shall be subjected to a load over 960 cm² applied to the approximate center of the sample section between the clamps and in a direction perpendicular to the direction of the tension force.

The sample shall withstand without rupture of any strand or opening of any mesh fastening, an actual load applied by means of a circular ram at a uniform rate not to exceed 220 N/s equaling or exceeding the values shown in [Table 7](#). The ram head used in the test shall be circular with a 350 mm diameter and have its edges bevelled or rounded to prevent cutting of the wire strands.

12.3 Pull-Apart Resistance Test/Selvedge Strength Test/Panel to Panel Connection

A set of two identical rectangular gabion panels, each with a width about $10\frac{1}{2}$ mesh openings along a selvedge wire, shall be joined by properly installed wire fasteners along the two selvedge wires so that each fastener confines two selvedge and two mesh wires. If the fasteners are also to be used to join two individual empty gabion baskets, two additional selvedge wires that are each mechanically wrapped with mesh wires shall be included so that each fastener confines four selvedge and four mesh wires. The set of the jointed panels shall be subject to pull-apart resistance test.

The specimen shall be mounted on a loading machine with grips or clamps such that the panels are uniformly secured along the full width. The grips or clamps shall be designed to only transmit tension forces. The load will then be applied at a uniform rate not to exceed 220 N/s until failure occurs. The failure is defined as when the maximum load is reached and a drop of strength is observed with subsequent loading or alternately the opening between any two closest selvedge wires, applicable to a fastener confining either two or four selvedge wires, becomes greater than 50 mm at any place along the panel width. The strength requirements of the jointed panels at failure shall be as shown in [Table 7](#). The results of the test shall be selvedge strength and panel to panel connection strength or pull apart strength. As shown in [Table 7](#), the values corresponding to above three terms

will be same for each type of double twist mesh. Different terminologies are just for indicating different mechanisms involved for different applications.

12.4 Metallic Coating Mass

Perform coating mass tests and adhesion tests as specified in IS 4826 or IS 12757 as applicable.

12.5 Polymer Coating Thickness

The thickness of the Polymer coating shall be determined on a randomly chosen individual piece of wire removed from the coil at 3 places 1 m apart.

Measure the diameter of the galvanized steel wire with polymer coating with a micrometre. Determine the thickness of the polymer coating by stripping the polymer coating from the wire and measure the reduced diameter with a micrometre. The thickness of the coating is the difference between the diameter of the galvanized steel wire with polymer coating and the measured diameter of the galvanized steel wire divided by two. The average value of thickness of the coating, shall be in accordance with [8.2](#) and [Table 1](#), [Table 2](#), [Table 3](#), [Table 4](#), [Table 5](#) and [Table 6](#). When removing the polymer coating by stripping, care to be taken, not to remove any of the metallic surfaces.

12.6 Polymer Coating — Resistance to Sodium Chloride Solution

12.6.1 Apparatus

12.6.1.1 Chamber or room, where the temperature is between 5 °C and 30 °C.

12.6.1.2 Scales, accurate to within 0.1 mg.

12.6.1.3 Test tube

12.6.2 Reagents — Saturated sodium chloride solution

12.6.3 Preparation of Test Specimen

Bend a 200 mm long piece of polymer coated wire into a U-shaped that it can fit in to the test tube.

12.6.4 Procedure

Weigh the test specimen and put it in the test tube. Fill the test tube with the sodium chloride solution such that the ends are 5 mm above the solution. After at least 60 h remove the test specimen from the solution, wash it, dry it and reweigh it. Check for compliance to [7.2](#) (d).

12.7 Polymer Coating

12.7.1 Abrasion Resistance Test

The test is for determination of the resistance of

polymer coated steel wire to abrasion by rubbing action. This is achieved by an abrading wire which moves back and forth along a linear path until it abrades through the polymer coating and the test is automatically stopped. Abrasion effect is prominent where there is scratching, wearing or rubbing effect caused by actions such as movement of solid objects, high bed load in flowing water, wave breaking at seashores or glaciation.

The sampling of polymer coated wire specimens used in the test shall be done randomly from production lot. A small section of polymer coating shall be stripped from both ends of the wire specimen before securing in place. A total vertical load of $2\,400\text{ g} \pm 50\text{ g}$ shall be applied to the abrading wire of $0.5\text{ mm} \pm 0.05\text{ mm}$ diameter as shown in Fig. 14. The test specimen shall be subjected to abrasion at a speed of 55 cycles ± 5 cycles per minute for a stroke length of 12.7 mm. The test shall stop automatically when the polymer coating is worn through to the metal wire. The number of cycles shall be recorded. A total of four tests shall be performed on each specimen. For each subsequent test, move the specimen 25 mm and rotate 90°. The abradant wire shall be replaced before each test. The average value of 4 tests performed shall be considered as final result.

High abrasion resistance coating shall be able to withstand on average greater than 300 cycles by linear abrading action.

12.7.2 Corrosion Spread Test

This test is relevant to assess in the event of local damage to an over-sheath, any consequential corrosion of the steel wire and ensure that the corrosion will remain confined to the damaged area of coating. The test procedure consists of immersing the wire samples of 250 mm length in 5 percent solution of HCl by weight. Samples are removed from the solution and analyzed after 100 hrs, 500 hrs, 1 000 hrs, 1 500 hrs and 2 500 hrs of immersion. The polymer coating shall be removed and the length of corroded wire measured. The part of the wire with reduced diameter is considered to be corroded. The average corrosion lengths measured versus time plot shall show the maximum length after which there is no more increase in length with respect to time. This maximum length measured shall be always less than one mesh repetition.

13 MARKING

13.1 Each finished product shall be marked legibly and indelibly with the following details on a metal tag:

- a) Name of manufacturer;
- b) Product type (gabions, revet mattresses,

sack gabion, soil reinforcement facia units or rock fall netting);

- c) Mesh type (10×12 , 8×10 or 6×8);
- d) Class of coating;
- e) Mesh wire size, in mm;
- f) Size, in m (length \times width \times height — For gabions, revet mattresses and soil reinforcement facia units, length and diameter for sack gabion and length \times width — for netting rolls);
- g) Batch No. or date of manufacturing; and
- h) Any other information as specified by the purchaser.

13.2 BIS Certification Marking

13.2.1 The product(s) conforming to the requirements of this standard may be certified as per the conformity assessment schemes under the provisions of the *Bureau of Indian Standards Act, 2016* and the Rules and Regulations framed thereunder, and the products may be marked with the Standard Mark.

13.3 The following information shall be supplied by the purchaser/indenter:

- a) Gabions, revet mattresses, sack gabions, soil reinforcement facia units or rock fall netting;
- b) Mesh type (10×12 , 8×10 or 6×8);
- c) Class;
- d) Mesh size and mesh wire diameter, in mm;
- e) Size, in m (length \times width \times height — For Gabions, revet mattresses, soil reinforcement facia units, length and diameter for sack gabions and length \times width — for netting rolls);
- f) IS number and year of issue;
- g) Quantity (number of units) for each class and size;
- h) Manufacturer's certificate, if required (see 14); and
- j) Any other requirement.

14 CERTIFICATES

When specified in the purchase order or contract, a manufacturer's certificate shall be furnished to the purchaser that the material has been manufactured, tested, and inspected in accordance with requirements of this standard and has been found to be conforming to the requirements. When specified in the contract or purchase order, reports of the test results for each batch supplied shall be furnished.

15 INSTALLATION MANUAL

The manufacturer shall supply installation manual for installation of the product.

Table 1 Mesh and Box Characteristics for Gabions(Clauses [5.5](#), [8.1](#), [8.2](#), [8.9](#) and [12.5](#))

SI No.	Characteristics	Mesh Type					
		10 × 12 D = 100 mm			8 × 10 D = 80 mm		
		Only Zinc/Zinc Alloy ² coated	Zinc/Zinc Alloy ² + Polymer		Only Zinc/Zinc Alloy ² coated	Zinc/Zinc Alloy ² + Polymer coated	
(1)	(2)	(3)	(4)	(5)	(6)	(7)	(8)
i)	Mesh wire dia, mm	2.70	3.00	2.70/3.70 ¹⁾	2.70	3.00	2.70/3.70 ¹⁾
ii)	Edge/Selvedge wire dia, mm	3.40	3.90	3.40/4.40 ¹⁾	3.40	3.90	3.40/4.40 ¹⁾
iii)	Lacing wire dia, mm	2.20	2.20	2.20/3.20 ¹⁾	2.20	2.20	2.20/3.20 ¹⁾
iv)	Polymer coating thickness, mm			Nominal — 0.50			Nominal — 0.50
		NA		Minimum — 0.40	NA		Minimum — 0.40
v)	Typical sizes Length × Width × Height (m)	4 × 1 × 1 (3 Nos.), 3 × 1 × 1 (2 Nos.), 2 × 1 × 1 (1 No.), 1.5 × 1 × 1 (0 No.), 2 × 1 × 0.5 (1 No.), 3 × 1 × 0.5 (2 Nos.), 4 × 1 × 0.5 (3 Nos.), 2 × 1 × 0.3 (1 No.), 3 × 1 × 0.3 (2 Nos.), 4 × 1 × 0.3 (3 Nos.)					
vi)	(Number of diaphragms) Tolerances in size of Units.	Length and Width... ± 5 percent; Height > 0.3 m... ± 5 percent and gabion boxes Height < 0.3 m... ± 10 percent					

NOTES

1 Internal diameter/External diameter of polymer coated wire.

2 Zinc Alloy shall consist of 90 percent Zinc + 10 percent Aluminium or 95 percent Zinc + 5 percent Aluminium

Table 2 Mesh and Box Characteristics for Revet Mattresses(Clauses [5.5](#), [8.1](#), [8.2](#), [8.9](#) and [12.5](#))

SI No.	Characteristics	Mesh Type 6 × 8 D = 60 mm	
		Only Zinc/Zinc Alloy ² coated	Zinc/Zinc Alloy ² + Polymer coated
(1)	(2)	(3)	(4)
i)	Mesh wire dia, mm	2.20	2.20/3.20 ¹⁾
ii)	Edge/selvedge wire dia, mm	2.70	2.70/3.70 ¹⁾
iii)	Lacing wire dia, mm	2.20	2.20/3.20 ¹⁾

Table 2 (Concluded)

Sl No.	Characteristics	Mesh Type 6 × 8 D = 60 mm	
		Only Zinc/Zinc Alloy ² coated	Zinc/Zinc Alloy ² + Polymer coated
(1)	(2)	(3)	(4)
iv)	Polymer coating thickness, mm	N.A	Nominal — 0.50 Minimum — 0.40
v)	Typical sizes Length × Width × Height (m) (Number of diaphragms)	4 × 2 × 0.17 (3 Nos.), 3 × 2 × 0.17 (2 Nos.), 2 × 2 × 0.17 (1 No.), 4 × 2 × 0.23 (3 Nos.), 3 × 2 × 0.23 (2 Nos.), 2 × 2 × 0.23 (1 No.), 4 × 2 × 0.30 (3 Nos.), 3 × 2 × 0.30 (2 Nos.), 2 × 2 × 0.30 (1 No.)	
vi)	Tolerances in size of units.	Length and Width... ± 5 percent; Height < 0.3 m... ± 10 percent	

NOTES

1 Internal diameter/External diameter of polymer coated wire.

2 Zinc Alloy shall consist of 90 percent zinc + 10 percent Aluminium or 95 percent Zinc + 5 percent Aluminium

Table 3 Mesh and Box Characteristics for Sack Gabions

Clauses [5.5](#), [8.1](#), [8.2](#), [8.9](#) and [12.5](#)

Sl No.	Characteristics	Mesh Type						
		10 × 12 D = 100 mm			8 × 10 D = 80 mm			
(1)	(2)	Only Zinc/Zinc Alloy ² coated		Zinc/Zinc Alloy ² + Polymer		Only Zinc/Zinc Alloy ² coated		Zinc/Zinc Alloy ² + Polymer coated
		(3)	(4)	(5)	(6)	(7)	(8)	
i)	Mesh wire dia, mm	2.70	3.00	2.70/3.70 ¹⁾		2.70	3.00	2.70/3.70 ¹⁾
ii)	Edge/Selvedge wire dia, mm	3.40	3.90	3.40/4.40 ¹⁾		3.40	3.90	3.40/4.40 ¹⁾
iii)	Lacing wire dia, mm	2.20	2.20	2.20/3.20 ¹⁾		2.20	2.20	2.20/3.20 ¹⁾
iv)	Polymer coating thickness, mm	NA		Nominal — 0.50 Minimum — 0.40		NA		Nominal — 0.50 Minimum — 0.40
v)	Typical sizes length × diameter (m)	1.5 × 0.74, 2 × 0.96						

Table 3 (Concluded)

SI No.	Characteristics	Mesh Type						
		10 × 12 D = 100 mm			8 × 10 D = 80 mm			
(1)	(2)	Only Zinc/Zinc Alloy ² coated	Zinc/Zinc Alloy ² + Polymer	Only Zinc/Zinc Alloy ² coated	Zinc/Zinc Alloy ² + Polymer coated	(6)	(7)	(8)
vi)	Tolerances in size of units	Length and Diameter... ± 5 percent; Height > 0.3 m... ± 5 percent and Height < 0.3 m... ± 10 percent						
NOTES								
1 Internal diameter/External diameter of polymer coated wire.								
2 Zinc Alloy shall consist of 90 percent zinc + 10 percent Aluminium or 95 percent Zinc + 5 percent Aluminium								

Table 4 Mesh and Unit Characteristics for Vertical Facing Units of Reinforced Soil Structures

(Foreword, Clauses 5.5, 8.1, 8.2, 8.9 and 12.5)

SI No.	Characteristics	Mesh Type		
		10 × 12 D = 100 mm	8 × 10 D = 80 mm	6 × 8 D = 60 mm
(1)	(2)	Zinc/Zinc Alloy ² + Polymer coated	Zinc/Zinc Alloy ² + Polymer coated	Zinc/Zinc Alloy ² + Polymer coated
(1)	(2)	(3)	(4)	(5)
i)	Mesh wire dia, mm	2.70/3.70 ¹⁾	2.70/3.70 ¹⁾	2.2/3.2 ¹⁾
ii)	Edge/Selvedge wire dia, mm	3.40/4.40 ¹⁾	3.40/4.40 ¹⁾	2.7/3.7 ¹⁾
iii)	Lacing wire dia, mm	2.20/3.20 ¹⁾	2.20/3.20 ¹⁾	2.20/3.20 ¹⁾
iv)	Polymer coating thickness, mm	Nominal — 0.50 Minimum — 0.40	Nominal — 0.50 Minimum — 0.40	Nominal — 0.50 Minimum — 0.40
v)	Typical size Length × Width × Height (m)	3 × 2 × 0.5 (1 No.), 3 × 3 × 0.5 (2 Nos.), 4 × 2 × 0.5 (1 No.), 4 × 3 × 0.5 (2 Nos.), 5 × 2 × 0.5 (1 No.), 5 × 3 × 0.5 (2 Nos.), 6 × 2 × 0.5 (1 No.), 6 × 3 × 0.5 (2 Nos.)		
	(Number of diaphragms)	3 × 2 × 1 (1 No.), 3 × 3 × 1 (2 Nos.), 4 × 2 × 1 (1 No.), 4 × 3 × 1 (2 Nos.), 5 × 2 × 1 (1 No.), 5 × 3 × 1 (2 Nos.) 6 × 2 × 1 (1 No.), 6 × 3 × 1 (2 Nos.) 3 × 2 × 0.8 (1 No.), 3 × 3 × 0.8 (2 Nos.), 4 × 2 × 0.8 (1 No.), 4 × 3 × 0.8 (2 Nos.), 5 × 2 × 0.8 (1 No.), 5 × 3 × 0.8 (2 Nos.), 3 × 2 × 0.8 (1 No.), 6 × 3 × 0.8 (2 Nos.)		
vi)	Tolerances in size of Units	Length and Width ± 5 percent; Height > 0.3 m ± 5 percent and Height < 0.3 m ± 10 percent		
NOTES				
1 Internal diameter/External diameter of Polymer coated wire.				
2 Zinc Alloy shall consist of 90 percent zinc + 10 percent Aluminium or 95 percent Zinc + 5 percent				

Table 5 Mesh and Unit Characteristics for Inclined Facing Units of Reinforced Soil Structures

(Foreword, Clauses 5.5, 8.1, 8.2, 8.9 and 12.5)

SI No.	Characteristics	Mesh Type		
		10×12 $D = 100$ mm Zinc/Zinc Alloy ² + Polymer coated	8×10 $D = 80$ mm Zinc/Zinc Alloy ² + Polymer coated	6×8 $D = 60$ mm Zinc/Zinc Alloy ² + Polymer coated
(1)	(2)	(3)	(4)	(5)
i)	Mesh wire dia, mm	2.70/3.70 ¹⁾	2.70/3.70 ¹⁾	2.2/3.2 ¹⁾
ii)	Edge/Selvedge wire dia, mm	3.40/4.40 ¹⁾	3.40/4.40 ¹⁾	2.7/3.7 ¹⁾
iii)	Lacing wire dia, mm	2.20/3.20 ¹⁾	2.20/3.20 ¹⁾	2.20/3.20 ¹⁾
iv)	Polymer coating thickness, mm	Nominal — 0.50 Minimum — 0.40	Nominal — 0.50 Minimum — 0.40	Nominal — 0.50 Minimum — 0.40
v)	Typical size Length \times Width \times Height (m) (face angle)	$3 \times 2 \times 0.63$ (45), $3 \times 2 \times 0.76$ (60), $3 \times 2 \times 0.80$ (65), $3 \times 2 \times 0.83$ (70), $3 \times 3 \times 0.63$ (45), $3 \times 3 \times 0.76$ (60), $3 \times 3 \times 0.8$ (65), $3 \times 3 \times 0.83$ (70), $4 \times 2 \times 0.63$ (45), $4 \times 2 \times 0.76$ (60), $4 \times 2 \times 0.80$ (65), $4 \times 2 \times 0.83$ (70), $4 \times 3 \times 0.63$ (45), $4 \times 3 \times 0.76$ (60), $4 \times 3 \times 0.8$ (65), $4 \times 3 \times 0.83$ (70), $5 \times 2 \times 0.63$ (45), $5 \times 2 \times 0.76$ (60), $5 \times 2 \times 0.80$ (65), $5 \times 2 \times 0.83$ (70), $5 \times 3 \times 0.63$ (45), $5 \times 3 \times 0.76$ (60), $5 \times 3 \times 0.8$ (65), $5 \times 3 \times 0.83$ (70), $6 \times 2 \times 0.63$ (45), $6 \times 2 \times 0.76$ (60), $6 \times 2 \times 0.80$ (65), $6 \times 2 \times 0.83$ (70), $6 \times 3 \times 0.63$ (45), $6 \times 3 \times 0.76$ (60), $6 \times 3 \times 0.8$ (65), $6 \times 3 \times 0.83$ (70), $3 \times 3 \times 0.73$ (65), $3 \times 3 \times 0.76$ (70), $3 \times 3 \times 0.79$ (80), $3 \times 3 \times 0.65$ (87), $4 \times 3 \times 0.73$ (65), $4 \times 3 \times 0.76$ (70), $4 \times 3 \times 0.79$ (80), $4 \times 3 \times 0.65$ (87), $5 \times 3 \times 0.73$ (65), $5 \times 3 \times 0.76$ (70), $5 \times 3 \times 0.79$ (80), $5 \times 3 \times 0.65$ (87), $6 \times 3 \times 0.73$ (65), $6 \times 3 \times 0.76$ (70), $6 \times 3 \times 0.79$ (80), $6 \times 3 \times 0.65$ (87),		
vi)	Tolerances in size of Units	Length and Width... ± 5 percent; Height > 0.3 m ± 5 percent and Height < 0.3 m ± 10 percent		

NOTES

1 Internal diameter/External diameter of Polymer coated wire.

2 Zinc Alloy shall consist of 90 percent zinc + 10 percent Aluminium or 95 percent Zinc + 5 percent

Table 6 Mesh and Roll Characteristics for Rockfall Netting

(Clauses 5.5, 8.1, 8.2, 8.11 and 12.6)

SI No.	Characteristics	Mesh Type							
		10 × 12 D = 100 mm			8 × 10 D = 80 mm			6 × 8 D = 60 mm	
		Only Zinc/Zinc Alloy ² coated	Zinc/Zinc Alloy ² + Polymer coated	Only Zinc/Zinc Alloy ² coated	Zinc/Zinc Alloy ² + Polymer coated	Only Zinc/Zinc Alloy ² coated	Zinc/Zinc Alloy ² + Polymer coated		
(1)	(2)	(3)	(4)	(5)	(6)	(7)	(8)	(9)	(10)
i)	Mesh wire dia, mm	2.70	3.00	2.70/3.70 ¹⁾	2.70	3.00	2.70/3.70 ¹⁾	2.2	2.2/3.2 ¹⁾
ii)	Edge/Selvage wire dia, mm	3.40	3.90	3.40/4.40 ¹⁾	3.40	3.90	3.40/4.40 ¹⁾	2.7	2.7/3.7 ¹⁾
iii)	Lacing wire dia, mm	2.20	2.20	2.20/3.20 ¹⁾	2.20	2.20	2.20/3.20 ¹⁾	2.20	2.20/3.20 ¹⁾
iv)	Polymer coating thickness, mm	NA	Nominal — 0.50 Minimum — 0.40	NA	Nominal — 0.50 Minimum — 0.40	NA	Nominal — 0.50 Minimum — 0.40	NA	Nominal — 0.50 Minimum — 0.40
v)	Typical size Length × Width	25 × 2, 25 × 3 and 25 × 4							
vi)	Tolerances in size of netting rolls	Length and Width... ± 5 percent; Height > 0.3 m... ± 5 percent and Length + 1.0m to -0.0m, width + "D"							

NOTES

1 Internal diameter/External diameter of Polymer coated wire.

2 Zinc Alloy shall consist of 90 percent zinc + 10 percent Aluminium or 95 percent Zinc + 5 percent

Table 7 Strength Requirements of Hexagonal Wire Mesh Panel for all Relevant Products

[Clauses 6.2, 11.2, 12.2 (b) and 12.3]

SI No.	Characteristics	Mesh Type						
		10 × 12 D = 100 mm			8 × 10 D = 80 mm		6 × 8 D = 60 mm	
		Only Zinc/Zinc Alloy ² coated	Zinc/Zinc Alloy ² + Polymer coated	Only Zinc/Zinc Alloy ² coated	Zinc/Zinc Alloy ² + Polymer coated	Only Zinc/Zinc Alloy ² coated	Zinc/Zinc Alloy ² + Polymer coated	
(1)	(2)	(3)	(4)	(5)	(6)	(7)	(8)	(9)
i)	Mesh wire dia, mm	2.70	3.00	2.70/3.70 ¹⁾	3.00	2.70/3.70 ¹⁾	2.20	2.2/3.2 ¹⁾
ii)	Tensile Strength Parallel to twist, kN/m	32.00	40.00	32.00	51.00	42.50	33.50	34.00

Table 7 (Concluded)

SI No.	Characteristics	Mesh Type								
		10 × 12 D = 100 mm			8 × 10 D = 80 mm		6 × 8 D = 60 mm			
(1)	(2)	Only Zinc/Zinc Alloy ² coated	Zinc/Zinc Alloy ² + Polymer coated	(5)	Only Zinc/Zinc Alloy ² coated	Zinc/Zinc Alloy ² + Polymer coated	(7)	Only Zinc/Zinc Alloy ² coated	Zinc/Zinc Alloy ² + Polymer coated	(9)
iii)	Tensile Strength Perpendicular to twist, kN/m	15.50	20.50	15.50	26.50	20.50		13.00	13.00	
iv)	Selvedge Strength, kN/m	10.20	11.22	10.20	20.40	16.32		10.20	10.20	
v)	Punch Strength, kN	17.80	19.58	17.8	26.70	21.36		17.80	17.80	
vi)	Panel to panel connection (lacing wire/ fasteners), kN/m	10.20	11.22	10.20	20.40	16.32		10.20	10.20	

NOTES

1 Internal diameter/External diameter of polymer coated wire.

2 Zinc alloy shall consist of 90 percent zinc + 10 percent aluminium or 95 percent

Table 8 Minimum Mass of Zinc/Zinc Alloy Coating for Heavily Coated, Soft Type for Different Wire Sizes used in Gabion, Sack Gabions, Revet Mattresses, Rockfall Netting and Facia Units for Reinforced Soil Structures

(Clauses 5.4.1 and 7.1.1)

SI No.	Nominal Diameter of Galvanized Wire mm	Mass of Zinc/Zinc Alloy Coating g/m ²	Permitted Tolerances on Wire Diameters mm
(1)	(2)	(3)	(4)
i)	2.00	240	± 0.05
ii)	2.20	240	± 0.06
iii)	2.40	260	± 0.06
iv)	2.70	260	± 0.07
v)	3.00	270	± 0.08
vi)	3.40	270	± 0.09
vii)	3.90	280	± 0.10

Table 9 Mesh Types and Sizes*(Clauses [5.4.1](#), [8.3](#), [8.4](#), [8.5](#), [8.6](#), [8.7](#), [8.8](#) and [8.12](#))*

Sl No.	Mesh Type	'D' Nominal Size	Tolerances
(1)	(2)	(3)	(4)
i)	10 × 12	100	+ 10 percent to – 10 percent
ii)	8 × 10	80	
iii)	6 × 8	60	

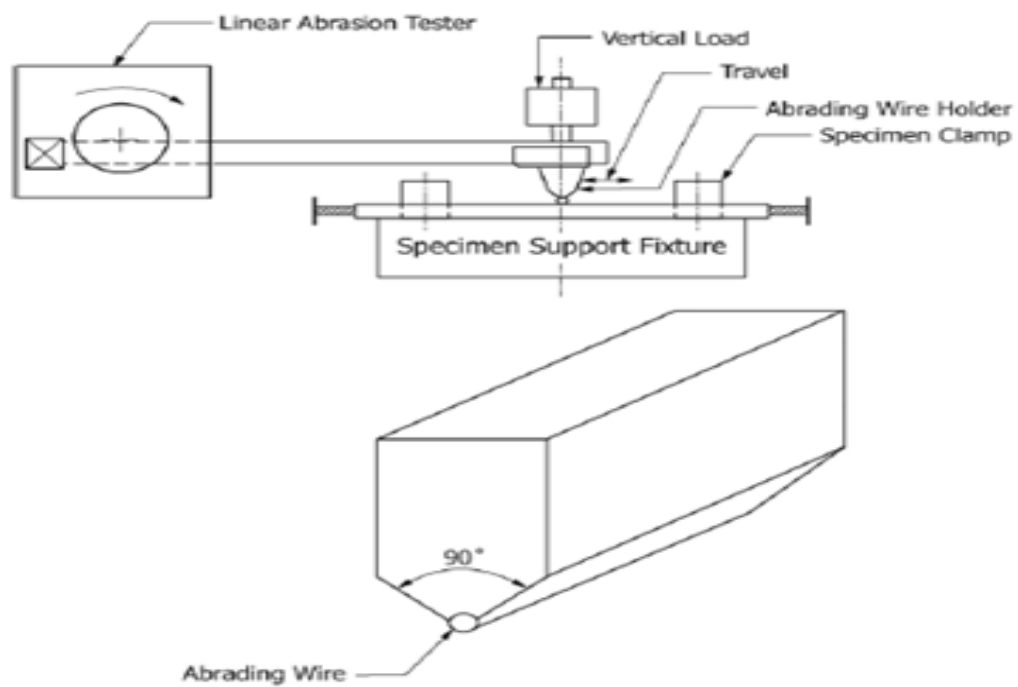

FIG. 14 LINEAR ABRADER

ANNEX A

(Clause 2)

LIST OF REFERRED STANDARDS

<i>IS No./Other Standards</i>	<i>Title</i>	<i>IS No./Other Standards</i>	<i>Title</i>
IS 280 : 2006	Mild steel wire for general engineering purposes (<i>fourth revision</i>)	(Sec 11) : 2013	Determination of indentation hardness) of plastics by means of durometer (shore hardness)
IS 4454 (Part 1) : 2001	Steel wires for mechanical springs — Specification: Part 1 Cold drawn unalloyed steel wires (<i>third revision</i>)	(Part 8/Sec 14) : 2018	Performance/Chemical properties, Section 14 Determination of the effects of exposure to damp heat, water spray and salt mist (<i>first revision</i>)
IS 4454 (Part 4) : 2001	Steel wires for mechanical springs — Specification: Part 4 Stainless Steel wire (<i>second revision</i>)		
IS 12753 : 1989	Electro galvanized coatings on round steel wire — Specification	ISO 37 : 2017	Rubber, vulcanized or thermoplastic — Determination of tensile stress-strain properties
IS 13360	Plastics — Methods of testing	ISO 974 : 2000	Plastics — Determination of the brittleness temperature by impact
(Part 3)	Physical and dimensional properties,	IS 4826 : 2023	Hot dipped galvanized coatings on round steel wires — Specification (<i>second revision</i>)
(Sec 10) : 2021	Determination of density of non-cellular plastics — Immersion method, liquid pycnometer method and titration method (<i>first revision</i>)	ISO 4892-3 : 2016	Plastics — Methods of exposure to laboratory light sources — Part 3 : Fluorescent UV lamps
(Sec 11) : 2021	Determination of density of non-cellular plastics — Density gradient column method (<i>first revision</i>)	ISO 9223 : 2012	Corrosion of metals and alloys — Corrosivity of atmospheres — Classification, determination and estimation
(Sec 12) : 2016	Determination of density of non-cellular plastics — Gas pycnometer method		
(Part 5)	Mechanical properties,	ISO 22479 : 2019	Corrosion of metals and alloys — Sulfur dioxide test in a humid atmosphere (fixed gas method)
(Sec 1) : 2021	Determination of tensile properties — General principles (<i>second revision</i>)		

To access Indian Standards click on the link below:

https://www.services.bis.gov.in/php/BIS_2.0/bisconnect/knowyourstandards/Indian_standards/isdetails/

ANNEX B

(Clause 4)

Table B-1 Description of Environment of Installation Site, Coating Wire Requirements

SI No.	Site Environment Level ^a (in Accordance with ISO 9223, Table 1)	Organic Coating Material	Coating	Class ^b	Assumed Working Life of the Product (years)
(1)	(2)	(3)	(4)	(5)	(6)
i)	Low aggressive: (C 2)	—	Zinc	A (Table A.2)	25
	Dry conditions	—	Zn 95 percent/Al 5 percent alloy	A (Table A.3)	> 50
	Temperate zone, atmospheric environment with low pollution, for example rural areas, small towns (over 100 m above sea level). Dry or cold zone, atmospheric environment with short time of wetness, for example deserts, sub-arctic areas	—	Zn 95 percent/Al 10 percent alloy	A (Table A.3)	> 120
ii)	Medium aggressive: (C 3)	—	Zinc	E (Table A.2)	10
	Dry conditions	—	Zn 95 percent/Al 5 percent alloy	A (Table A.3)	25
	Temperate zone, atmospheric environment with medium pollution or some effect of chlorides, for example urban areas, coastal areas with low deposition of chlorides, for example subtropical and tropical zone, atmosphere with low pollution	—	Zn 90 percent/Al 10 percent alloy	A (Table A.3)	> 50
		Polyvinyl Chloride (PVC)	Zn 95 percent/ Al 5 percent alloy	A (Table A.3)	120
		Polyamide (PA6)	Zn 90 percent/Al 10 percent alloy	A (Table A.3)	> 120
		HAR Polymer	Zn 95 percent/Al 10 percent alloy	E (Table A.3)	
iii)	High aggressive: (C 4)	—	Zn 95 percent/Al 10 percent alloy	A (Table A.3)	25
	Wet conditions temperate zone,	—	Zn 90 percent/Al 10 percent alloy	A (Table A.3)	10
	atmospheric environment with high pollution or substantial effect of chlorides, for example polluted urban areas, industrial areas, coastal areas, without spray of salt water, exposure to strong effect of de-icing salts, for example subtropical and tropical zone, atmosphere with medium pollution	Polyvinyl Chloride (PVC)	Zn 90 percent/Al 10 percent alloy	A (Table A.3)	120
	Polyamide (PA6)	Zn 90 percent/Al 10 percent alloy	E (Table A.3)		
	HAR Polymer	Zn 90 percent/Al 10 percent alloy	E (Table A.3)		

Table B-1 (Concluded)

SI No.	Site Environment Level ^a (in Accordance with ISO 9223, Table 1)	Organic Coating Material	Coating	Class ^b	Assumed Working Life of the Product (years)
(1)	(2)	(3)	(4)	(5)	(6)
	industrial areas, coastal areas, shelter positions at coastline	Polyvinyl Chloride (PVC)	Zn 90 percent/Al	A (Table A.3)	> 120
		Polyamide (PA6) HAR Polymer	10 percent alloy	E (Table A.3)	
iv)	Very high aggressive: (C 5) Wet conditions Temperate and subtropical zone, atmospheric environment with very high pollution and/or important effect of chlorides, for example industrial areas, coastal areas, shelter positions at coastline.	Polyvinyl Chloride (PVC)	Zn 95 percent/Al	A (Table A.3)	120
		Polyamide (PA6) HAR Polymer	5 percent alloy	E (Table A.3)	
	Subtropical and tropical zone (very high time of wetness), atmospheric environment with very high pollution SO ₂ (higher than 250 µg/m ³) including accompanying and production ones and/or strong effect of chlorides, for example extreme industrial areas, coastal and offshore areas, occasionally contact with salt spray.	Polyvinyl Chloride (PVC)	Zn 90 percent/Al	A (Table A.3)	> 120
		Polyamide (PA6) HAR Polymer	10 percent alloy	E (Table A.3)	
v)	Extreme aggressive: (C X) Subtropical and tropical zone (very high time of wetness), atmospheric environment with very high pollution SO ₂ (higher than 250 µg/m ³) including accompanying and production ones and/or strong effect of chlorides, for example extreme industrial areas, coastal and off shore areas, occasionally contact with salt spray.	Polyvinyl Chloride (PVC)		A (Table A.3)	> 120
		Polyamide (PA6) HAR Polymer	Zn 90 percent/Al	E (Table A.3)	

Table B-2 Mass requirements for a coating of Zn

SI No.	Diameter d mm	Classes ^a					
		A g/m ²	AB g/m ²	B g/m ²	C g/m ²	D g/m ²	Ax3 ^b g/m ²
(1)	(2)	(3)	(4)	(5)	(6)	(7)	(8)
i)	0.15 ≤ d < 0.20	–	–	15	–	10	–
ii)	0.20 ≤ d < 0.25	30	20	20	20	15	–

Table B-2 (Concluded)

Sl No.	Diameter d mm	Classes ^a					
		A g/m ²	AB g/m ²	B g/m ²	C g/m ²	D g/m ²	Ax3 ^b g/m ²
(1)	(2)	(3)	(4)	(5)	(6)	(7)	(8)
iii)	$0.25 \leq d < 0.32$	45	30	30	25	15	–
iv)	$0.32 \leq d < 0.40$	60	30	30	25	15	–
v)	$0.40 \leq d < 0.50$	85	55	40	30	15	–
vi)	$0.50 \leq d < 0.60$	100	70	50	35	15	–
vii)	$0.60 \leq d < 0.70$	115	80	60	40	20	–
viii)	$0.70 \leq d < 0.80$	130	90	60	45	20	–
ix)	$0.80 \leq d < 0.90$	145	100	70	50	20	–
x)	$0.90 \leq d < 1.00$	155	110	70	55	20	–
xi)	$1.00 \leq d < 1.20$	165	115	80	60	25	–
xii)	$1.20 \leq d < 1.40$	180	125	90	65	25	540
xiii)	$1.40 \leq d < 1.65$	195	135	100	70	25	585
xiv)	$1.65 \leq d < 1.85$	205	145	100	75	30	615
xv)	$1.85 \leq d < 2.15$	215	155	115	80	30	645
xvi)	$2.15 \leq d < 2.50$	230	170	125	85	40	690
xvii)	$2.50 \leq d < 2.80$	245	185	125	95	45	735
xviii)	$2.50 \leq d < 3.20$	255	195	135	100	50	765
xix)	$3.20 \leq d < 3.80$	265	210	135	105	60	795
xx)	$3.80 \leq d < 4.40$	275	220	135	110	60	825
xxi)	$4.40 \leq d < 5.20$	280	220	150	110	70	840
xxii)	$5.20 \leq d < 8.20$	290	–	–	110	80	870
xxiii)	$8.20 \leq d < 10.00$	300	–	–	110	80	900

NOTES

1 The coating class with a designation starting with A relates to thick coatings (generally final coating). Designations ending in B relate to classes usually but not always obtained by (zinc coating) and subsequent drawing. Classes C and D are standard classes for low mass coating which are usually produced but not exclusively, produced by hot zinc dipping and then wiping.

2 $A \times 3$ relates to very high mass requirement three times higher than class A. Other multiples of Class A are possible and these classes will be identified in the same way, for example $A \times 4$.

Table B-3 Mass requirements for a coating of Zn95Al5

Sl No.	Diameter d mm	Classes ^a			
		A g/m ²	AB g/m ²	B g/m ²	E ^b g/m ²
(1)	(2)	(3)	(4)	(5)	(6)
i)	$0.20 \leq d < 0.25$	–	20	20	
ii)	$0.25 \leq d < 0.40$	–	30	30	

Table B-3 (Concluded)

Sl No.	Diameter d mm	Classes ^a			
		A g/m ² (3)	AB g/m ² (4)	B g/m ² (5)	E ^b g/m ² (6)
(1)	(2)	(3)	(4)	(5)	(6)
iii)	0.40 ≤ d < 0.50	85	55	40	
iv)	0.50 ≤ d < 0.60	100	70	50	40
v)	0.60 ≤ d < 0.70	115	80	60	
vi)	0.70 ≤ d < 0.80	130	90	60	
vii)	0.80 ≤ d < 0.90	145	100	70	
viii)	0.90 ≤ d < 1.00	155	110	70	
ix)	1.00 ≤ d < 1.20	165	115	80	
x)	1.20 ≤ d < 1.40	180	125	90	
xi)	1.40 ≤ d < 1.65	195	135	100	
xii)	1.65 ≤ d < 1.85	205	145	100	
xiii)	1.85 ≤ d < 2.15	215	155	115	
xiv)	2.15 ≤ d < 2.50	230	170	125	
xv)	2.50 ≤ d < 2.80	245	185	125	
xvi)	2.80 ≤ d < 3.20	255	195	135	60
xvii)	3.20 ≤ d < 3.80	265	210	135	
xviii)	3.80 ≤ d < 4.40	275	220	135	
xix)	4.40 ≤ d < 5.20	280	220	150	
xx)	5.20 ≤ d < 8.20	290	–	–	
xxi)	8.20 ≤ d < 10.00	300	–	–	

NOTES

1 The coating class with a designation starting with A relates to thick coatings (generally final coating). Designations ending in B relate to classes usually but not always obtained by (zinc coating) and subsequent drawing.

2 the corrosion resistance of this class E must be at least equivalent of these from a zinc coating according Table A.2 class B

- a) Gabion products immersed in water (saline and/or polluted water) and/or in contact with alkaline solutions, or gabions which are subject to abrasive conditions (sand storms, etc.) shall be metallic-coated or organic coated or shall be made from stainless steel wire.
- b) There exist more advanced metallic coatings with superior corrosion resistance. In terms of salt spray performance (EN ISO 9227), it means that the mesh samples shall not show more than 5 percent of DBR (dark brown rust) after 2 000 h of exposure on the surface, When subjected to test in sulphur Dioxide environment (ISO 6988), mesh samples shall not show more than 5 percent of DBR (dark brown rust) after 56 cycles of discontinuous test on the surface. So assumed working life values will be improved depending upon the prevailing conditions.

Working life (product) - the period of time during which the performance of a product will be maintained at a level that enables properly designed and executed works to fulfill the essential requirements (that is the essential characteristics of a product meet or exceed minimum acceptable values, without incurring major costs for repair or replacement). The working life of a product depends upon its inherent durability and normal installation and maintenance.

ANNEX C

(Foreword)

COMMITTEE COMPOSITION

Wire Ropes and Wire Products Sectional Committee, MED 10

<i>Organization</i>	<i>Representative(s)</i>
Directorate General of Mines Safety, Dhanbad	SHRI D. B. NAIK (Chairperson) SHRI VIJAY BARAPATRE (<i>Alternate</i>)
Bharat Heavy Electrical Limited, New Delhi	SHRI BHASKARJIT BARUA SHRI RAMAN BHARIHOKE (<i>Alternate I</i>) SHRI DEVENDRA SINGH RATHORE (<i>Alternate II</i>)
Bharat Wire Ropes Limited, Mumbai	SHRI MAHENDER SINGH ARORA SHRI MAYANK MITTAL (<i>Alternate</i>)
Central Institute of Mining and Fuel Research, Dhanbad	DR MANOJ KUMAR SINGH, DR DEBASISH BSSAK (<i>Alternate</i>)
Directorate General Factory Advice Service and Labour Institutes, Mumbai	SHRI SAMIR PANDEY SHRI N. VARADHARAJAN (<i>Alternate</i>)
Maccaferri Environment Solutions Pvt Limited, Navi Mumbai	SHRIMATI MINIMOL KORULLA SHRI RUDRA BUDDHABHATTI (<i>Alternate</i>)
Ministry of Ports, Shipping and Waterways, New Delhi	SHRI ANIL PRUTHI SHRI RAMJI SINGH (<i>Alternate</i>)
Nanda and Miller Co, Kolkata	SHRI J. P. GOENKA
National Test House, Kolkata	SHRI SURESH PARWAL SHRI ANGAD VERMA (<i>Alternate</i>)
Oil and Natural Gas Corporation Limited, New Delhi	SHRI RITUJIT HAZARIKA SHRI RAKESH KUMAR SRIVASTAVA (<i>Alternate</i>)
Orient Wire Ropes, Indore	SHRI RUSHIKESH AKARTE
Otis Elevator Company (India) Limited, Bengaluru	SHRI SHRIHARI VISPUTE SHRI PRAVEENA SIDDARAMANNA (<i>Alternate</i>)
Schindler India Private Limited, Mumbai	SHRI NITIN VITHAL KADAM SHRI KETAN KSHIRSAGAR (<i>Alternate</i>)
TK Elevator India Private Limited, Navi Mumbai	SHRI VISHNU PARASHAR SHRI DEEPAK BALANI (<i>Alternate</i>)
Usha Martin Industries Limited, Ranchi	SHRI SUBRATA DUTTA SHRI SANDEEP JAISWAL (<i>Alternate</i>)
Vedanta Limited, Mumbai	SHRI RAKESH SINGHIV
BIS Directorate General	SHRI K. V. RAO SCIENTIST 'F'/SENIOR DIRECTOR AND HEAD (MECHANICAL ENGINEERING) [REPRESENTING DIRECTOR GENERAL (<i>Ex-officio</i>)]

Member Secretary
SHRI SANDEEP KESHAV
SCIENTIST 'C'/DEPUTY DIRECTOR
(MECHANICAL ENGINEERING), BIS

Bureau of Indian Standards

BIS is a statutory institution established under the *Bureau of Indian Standards Act, 2016* to promote harmonious development of the activities of standardization, marking and quality certification of goods and attending to connected matters in the country.

Copyright

BIS has the copyright of all its publications. No part of these publications may be reproduced in any form without the prior permission in writing of BIS. This does not preclude the free use, in the course of implementing the standard, of necessary details, such as symbols and sizes, type or grade designations. Enquiries relating to copyright be addressed to the Head (Publication & Sales), BIS.

Review of Indian Standards

Amendments are issued to standards as the need arises on the basis of comments. Standards are also reviewed periodically; a standard along with amendments is reaffirmed when such review indicates that no changes are needed; if the review indicates that changes are needed, it is taken up for revision. Users of Indian Standards should ascertain that they are in possession of the latest amendments or edition by referring to the website- www.bis.gov.in or www.standardsbis.in.

This Indian Standard has been developed from Doc No.: MED 10 (24593).

Amendments Issued Since Publication

Amend No.	Date of Issue	Text Affected

BUREAU OF INDIAN STANDARDS

Headquarters:

Manak Bhavan, 9 Bahadur Shah Zafar Marg, New Delhi 110002
Telephones: 2323 0131, 2323 3375, 2323 9402

Website: www.bis.gov.in

Regional Offices:

	Telephones
Central : 601/A, Konnectus Tower -1, 6 th Floor, DMRC Building, Bhavbhuti Marg, New Delhi 110002	{ 2323 7617
Eastern : 8 th Floor, Plot No 7/7 & 7/8, CP Block, Sector V, Salt Lake, Kolkata, West Bengal 700091	{ 2367 0012 2320 9474
Northern : Plot No. 4-A, Sector 27-B, Madhya Marg, Chandigarh 160019	{ 265 9930
Southern : C.I.T. Campus, IV Cross Road, Taramani, Chennai 600113	{ 2254 1442 2254 1216
Western : 5 th Floor/MTNL CETTM, Technology Street, Hiranandani Gardens, Powai, Mumbai 400076	{ 2570 0030 2570 2715

Branches : AHMEDABAD, BENGALURU, BHOPAL, BHUBANESHWAR, CHANDIGARH, CHENNAI, COIMBATORE, DEHRADUN, DELHI, FARIDABAD, GHAZIABAD, GUWAHATI, HARYANA (CHANDIGARH), HUBLI, HYDERABAD, JAIPUR, JAMMU, JAMSHEDPUR, KOCHI, KOLKATA, LUCKNOW, MADURAI, MUMBAI, NAGPUR, NOIDA, PARWANOO, PATNA, PUNE, RAIPUR, RAJKOT, SURAT, VIJAYAWADA.