खदानों में उपयोग के लिए ज्वालासह हैंड-
हेल्ड रोटरी इलेक्ट्रिक ड्रिलिंग मशीन —
विशिष्टि

(पहला पुनरीक्षण)

**Flameproof Hand-Held Rotary
Electric Drilling Machine for Use in
Mines — Specification**

(*First Revision*)

ICS 73.100.01

© BIS 2023



भारतीय मानक ब्यूरो
BUREAU OF INDIAN STANDARDS
मानक भवन, 9 बहादुर शाह ज़फर मार्ग, नई दिल्ली - 110002
MANAK BHAVAN, 9 BAHADUR SHAH ZAFAR MARG
NEW DELHI - 110002
www.bis.gov.in www.standardsbis.in

FOREWORD

This Indian Standard (First Revision) was adopted by the Bureau of Indian Standards, after the draft finalized by the Mining Techniques and Equipment Sectional Committee had been approved by the Mechanical Engineering Divisional Council.

This standard was first published in 1979. This revision has been taken up with a view to incorporate the modification found necessary as a result of experience gained in the use of this standard. Also, in this revision, the standard has been brought into the latest style and format of Indian Standards, and references to Indian Standards, wherever applicable have been updated. BIS certification marking clause has been modified to align with the revised *Bureau of Indian Standard Act, 2016*. The following major modifications have been incorporated in this revision of the standard.

Compliance with this standard does not of itself guarantee that satisfactory service will be attained. Conditions of use vary greatly and it is necessary to relate the standards of performance to the actual use to which the device will be subjected during its life.

This standard specifies the constructional and performance requirements of flameproof hand-held rotary electric drilling machine for use in mines.

The composition of the Committee responsible for the formulation of this standard is given in [Annex C](#).

For the purpose of deciding whether a particular requirement of this standard is complied with, the final value, observed or calculated, expressing the result of a test or analysis, shall be rounded off in accordance with IS 2 : 2022 'Rules for rounding off numerical values (*second revision*)'. The number of significant places retained in the rounded off value should be the same as that of the specified value in this standard.

*Indian Standard***FLAMEPROOF HAND-HELD ROTARY ELECTRIC DRILLING
MACHINE FOR USE IN MINES — SPECIFICATION***(First Revision)***1 SCOPE**

This standard covers the requirements for flameproof hand-held rotary electric drilling machine for use in mines.

2 REFERENCES

The standards listed in [Annex A](#) contain provisions which, through reference in this text, constitute provisions of this standard. At the time of publication, the editions indicated were valid. All standards are subject to revision and parties to the agreement based on this standard are encouraged to investigate the possibility of applying the most recent editions of the standards.

3 MATERIAL

Material used in the construction of various components for the drill shall have mechanical properties as specified in [Table 1](#). For guidance the recommended material for manufacture of various components are also listed in [Table 1](#).

Aluminum, magnesium and titanium or their alloys shall not be used for manufacture of external casing of the drill.

4 GENERAL REQUIREMENTS**4.1 General**

4.1.1 The enclosures of the electrical apparatus, such as motor, switch, plug and socket, shall conform to the requirements of [IS/IEC 60079-1](#).

4.1.2 The moving parts of the fan shall not be directly accessible in normal working condition.

4.1.3 The drill shall be of robust construction to withstand the duty conditions required in mines.

4.1.4 The drill shall be designed for easy dismantling for maintenance of renewable components, various covers, such as motor end covers, switch covers, cable couplers, etc, provided for maintenance shall be designed such that their repeated dismantling shall not cause any damage

likely to effect the flameproof characteristic of the drill.

4.2 Motor

4.2.1 The drill shall have a squirrel cage induction motor suitable for operation on 125 V, 3 phase 50 Hz a.c. supply and shall conform to the requirements of [IS 12615](#).

4.2.2 The motor shall be capable of giving power output of 1.1 kW, *Max* at declared speed of chuck for a period of 30 min continuously, without exceeding the temperature rise as specified in [Table 2](#). The current at this output shall not exceed 15 A.

4.2.3 The windings of motor may have insulation of Class E or B but insulation of Class B shall be preferred.

4.3 Switch

4.3.1 The switch for operating the motor shall be designed to be operated by a spring-loaded trigger placed in the handle of the machine and shall be able to break contact at the release of the trigger. The switch shall be dust-proof and shall be housed in a flameproof enclosure conforming to [IS/IEC 60079-1](#).

4.3.2 The switch shall be a single pole switch for a.c. or d.c. applications.

4.3.3 If required by customer and in accordance with [IS/IEC 60079-1](#), arrangement shall be made adjacent to the switch for fixing a diode in the earth line of the switch circuit for pilot core protection.

4.4 Plug and Socket

4.4.1 The drill shall be fitted with a bolted type cable coupler and adapter suitable to receive cables of type FTD 2 and FTD 3 conforming to [IS 14494](#).

4.4.1.1 The bolted type of cable couplers shall be designed to carry 15 A at 125 V.

4.4.1.2 The restrained type cable couplers and adaptors shall not be used.

Table 1 Materials for Components for Drills

(Clause 3)

SI No.	Components	Tensile Strength, <i>Min</i> N/mm ²	Hardness HV (\approx HB), <i>Min</i>	Recommended Materials	Remarks
(1)	(2)	(3)	(4)	(5)	(6)
i)	External casing of drill	225		IS 2062 or IS 14329 or IS 1865 or IS 1570 (all parts)	Mass of the complete drill shall not exceed 23 kg
ii)	Fasteners	395	—	—	—
iii)	Contact pins of couplers	—	74(70)	IS 613 or IS 320	—
iv)	Contact tubes of adaptors	—	74(70)	IS 7811 'Phosphor bronze rods and bars' or copper, or any similar material	—

Table 2 Limits of Temperature Rise

(Clause 4.2.2 and Table 3)

SI No.	Part	Temperature Rise	Class of Insulation	Measured by
(1)	(2)	(3)	(4)	(5)
i)	Winding	75 °C	E	Resistance method
		80 °C	B	Resistance method
ii)	Magnetic core and other parts in contact with windings	75 °C	E	Thermometer
		80 °C	B	Thermometer
iii)	External casing (excluding handle and fan cowling)	40 °C	—	Thermometer
iv)	Handle and fan cowling	20 °C	—	Thermometer

4.4.1.3 In case of 5-point couplers and adaptors, the pin connected to pilot core shall make the contact with its tube, after and break before, the pins connected to the power cores of the cable make or break the contacts with the respective tubes.

4.4.2 All external metallic parts of the drill shall be in effective electrical connection with the earthing conductor through a mechanically secured and electrically efficient attachment.

4.4.3 Provision shall be made for firm gripping of the cable within socket assembly or in equally effective manner, in order to avoid undue tension in power terminals. The gripping arrangement shall

withstand the weight of the drill when suspended and shall also be able to prevent entry of water in the plug and socket.

4.5 Chuck

4.5.1 The chuck dimensions shall be in accordance with [Fig. 1](#). The driving slots shall be effectively shrouded and shall be able to engage effectively with drill rods conforming to [IS 7868](#).

NOTE — The chucks designed with dimensions other than those specified in [Fig. 1](#) shall be deemed to comply with this standard provided they satisfy all other relevant requirements specified herein.

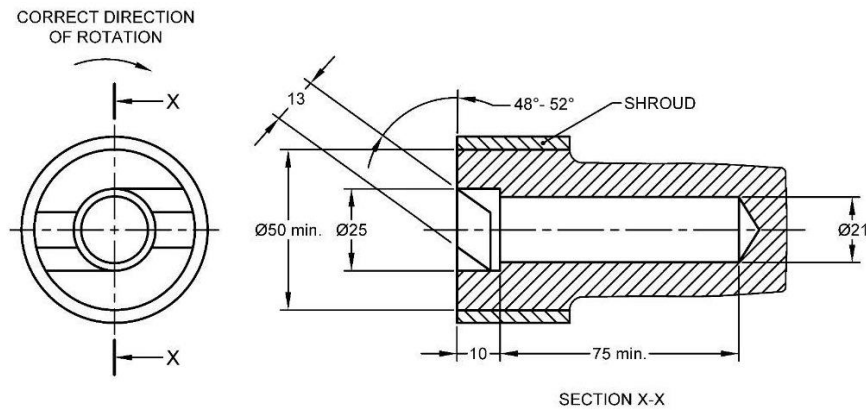

All dimensions in millimetres.

FIG. 1 DIMENSIONS OF CHUCK

4.5.2 The chuck shall have a minimum hardness of 390 HV.

4.5.3 The chuck speed shall preferably be between 400 rev/min to 600 rev/min as agreed between the manufacturer and the user.

4.6 Handles

The position of handles with respect to the centre line of the chuck shall be such that the force on each handle does not exceed 265 N under maximum torque conditions.

5 MARKING

5.1 Each drill shall be marked with the following information:

- Manufacturer's name and identification mark;
- Type designation, serial number and year of manufacture;
- Rated voltage current, frequency, output power and insulation grade;
- Chuck speed; and
- Direction of rotation of chuck.

5.2 BIS Certification Marking

The product(s) conforming to the requirements of this standard may be certified as per the conformity assessment schemes under the provisions of the *Bureau of Indian Standards Act, 2016* and the Rules and Regulations framed thereunder, and the products may be marked with the Standard Mark.

6 TESTS

6.1 Tests as specified in [Table 3](#) shall be conducted by the manufacturer on one drill out of a batch of

20 drills or part thereof for type tests. For routine test these tests shall be conducted on each drill.

NOTE — The test results shall be recorded on proforma as given in [Annex B](#).

6.1.1 For type tests, instruments of class 0.5 accuracy shall be used [*see* [IS 1248 \(Part 8\)](#)] and for routine tests instruments of class 1.0 accuracy shall be used [*see* [IS 1248 \(Part 8\)](#)].

6.2 High Voltage Test

6.2.1 For Switch

The test voltages of 500 V (sinusoidal a.c.) shall be applied for 5 s between the contacts of the switch and also between the pilot terminal of the switch and the frame.

6.2.1.1 Initially 50 percent of test voltages shall be applied which shall be increased gradually to its full rated test voltage in a period of not less than 10 s and shall be maintained for test period mentioned in [6.2.1](#).

6.3 Stalled Rotor Test

A balanced sinusoidal 125 V, 3 phase supply shall be applied to the stator of drill motor, rotor being locked. The stalled current shall not exceed 40 A. The motor shall be capable of carrying, without injury and after it has attained the temperature corresponding with its rating, the current of the stalled machine for a period of 15 s.

6.4 Operational Test for Switch

6.4.1 The tests as mentioned in [6.4.2](#) and [6.4.3](#) shall be carried out on one switch out of a batch of 1 000 switches or part thereof to check the mechanical and electrical endurance of the switch

and shall be conducted at the supply frequency for which the drill is designed.

6.4.2 Switches designed to make and break the control circuit shall be tested for 10 000 operations, when carrying a current of 1 A at 50 V dc. The switch shall be able to withstand this test without mechanical or electrical breakdown.

6.4.3 Switches designed to make and break line current directly shall be tested for 5 000 operations when carrying three-phase current equal to that of

the motor when stalled. The switch shall be able to withstand this test without suffering mechanical or electrical breakdown and without any flash occurring between terminals or between terminal and frame.

6.4.3.1 For the purpose of this test the voltage between phases, as measured at the terminal of the switch, shall be not less than 125 V on open circuit and not less than 100 V at the prescribed current, at a power factor equal to that of the motor when stalled.

Table 3 Test for Drill

(Clause [6.1](#))

SI No.	Particulars of Test	Nature of Test	IS/IEC 60079-1 Ref to Cl No.	IS 12615 Ref to Cl No.	IS 4029 ¹⁾ Ref to Cl No.	Ref to Cl No. in This Standard	Remark
(1)	(2)	(3)	(4)	(5)	(6)	(7)	(8)
i)	Hydraulic test	Type and routine	16	—	—	—	—
ii)	Insulation resistance test	Type and routine	—	16.1.1	—	—	—
iii)	DC stator resistance test	Type and routine	—	—	7	—	—
iv)	No load test	Type and routine	—	—	8.1	—	—
v)	Reduced voltage running test	Type and routine	—	16.1.5	—	—	—
vi)	High voltage test:						
	a) Motor	Type and routine	—	16.1.6	—	—	—
	b) Switch	Type	—	—	—	6.2.1	—
vii)	Locked rotor test	Type and routine	—	—	8.3 and 8.4	—	—
viii)	Stalled rotor test	Type	—	—	—	6.3	—
ix)	Load test	Type	—	—	8.8	—	—
x)	Temperature rise test	Type	—	16.2.4	—	—	Temperature rise shall lie within the limits specified in Table 2
xi)	Momentary overload test	Type	—	16.2.5	—	—	—
xii)	Operational test for switch	Endurance	—	—	—	6.4	—

¹⁾ Guide for testing three-phase induction motors.

ANNEX A

(Clause 2)

LIST OF REFERRED STANDARDS

<i>IS No.</i>	<i>Title</i>	<i>IS No.</i>	<i>Title</i>
IS 320 : 1980	Specification for high tensile brass rods and sections (other than forging stock) (<i>second revision</i>)	(Part 5) : 1985	Stainless and heat-resisting steels (<i>second revision</i>)
IS 613 : 2000	Copper rods and bars for electrical purposes — Specification (<i>third revision</i>)	(Part 6) : 1996	Carbon and alloy tool steels (<i>first revision</i>)
IS 1248 (Part 8) : 2021	Direct acting indicating analogue electrical measuring instruments and their accessories: Part 8 Special requirements for accessories (<i>fourth revision</i>)	(Part 7) : 1992	Steels for elevated temperature service (creep resistant steels)
IS 1570	Schedules for wrought steels:	IS 1865 : 1991	Iron castings with spheroidal or nodular graphite — Specification (<i>third revision</i>)
(Part 1) : 1978	Steels specified by tensile and/or yield properties (<i>first revision</i>)	IS 2062 : 2011	Hot rolled medium and high tensile structural steel — Specification (<i>seventh revision</i>)
(Part 2)	Carbon steels (unalloyed steels) (<i>first revision</i>),	IS 4029 : 2010	Guide for testing three phase induction motors (<i>first revision</i>)
(Sec 1) : 1979	Wrought products (other than wires) with specified chemical composition and related properties (<i>first revision</i>)	IS 7811 : 2019	Phosphor bronze rods and bars (<i>second revision</i>)
(Sec 2) : 1987	Carbon steel wires with related properties (<i>first revision</i>)	IS 7868 : 1975	Specification for rotary drill rods for drilling principally in coal
(Part 3) : 1979	Carbon and carbon-manganese free cutting steels (<i>first revision</i>)	IS 12615 : 2018	Line operated three phase a.c. motors (IE CODE) “efficiency classes and performance specification” (<i>third revision</i>)
(Part 4) : 1988	Alloy steels (alloy constructional and spring steels) with specified chemical composition and related mechanical properties (<i>first revision</i>)	IS 14329 : 1995	Malleable iron castings — Specification
		IS 14494 : 2019	Elastomer insulated flexible cables for use in mines — Specification (<i>first revision</i>)
		IS/IEC 60079-1 : 2014	Explosive atmospheres: Part 1 Equipment protection by flameproof enclosures “d” (<i>first revision</i>)

To access Indian Standards click on the link below:

https://www.services.bis.gov.in/php/BIS_2.0/bisconnect/knowyourstandards/Indian_standards/isdetails/

ANNEX B

(Clause 6.1)

FORM FOR TEST REPORT OF DRILL

Name and address of manufacturer

Certificate No.

B-1 GENERAL INFORMATION

<i>Output</i> kW	<i>Chuck Speed</i> rev/min	<i>Hertz</i> Hz	<i>Volts</i> V	<i>Full Load,</i> A	<i>Rating</i> <i>Model No.</i>	<i>Temperature</i> <i>Rise,</i> °C	<i>Class of Insulation</i>

B-2 HYDRAULIC TEST

<i>Sl No.</i>	<i>Components/Assembly</i>	<i>Test Pressure</i>	<i>Duration of Test</i>	<i>Test Result</i>	<i>Acceptance</i>

B-3 FOR ROUTINE TESTING

<i>Volts</i>	<i>No Load</i>			<i>Locked Rotor</i>			<i>Insulation</i> <i>Resistance</i> MΩ	<i>High</i> <i>Voltage</i> V s	<i>dc Stator</i> <i>Resistance</i> Ω
	<i>Amperes</i> A	<i>Amperes</i> A	<i>Amperes</i> A	<i>Volts</i> V	<i>Amperes</i> A	<i>Amperes</i> A			

B-3.1 Reduced Voltage Running Test

The drill runs up to full speed on no load with V applied to stator.

B-4 FOR TYPE TESTING

B-4.1 Loading Characteristics

<i>Sl No.</i>	<i>Loading</i>	<i>Volts</i>	<i>Amperes</i>	<i>Amperes</i>	<i>Watts</i>	<i>Chuck</i> <i>Speed</i>	<i>Hours</i> <i>Run</i>	<i>Power Factor</i>		<i>Efficiency</i>	
								<i>Tested</i>	<i>Guaranteed</i>	<i>Tested</i>	<i>Guaranteed</i>
(1)	(2)	(3)	(4)	(5)	(6)	(7)	(8)	(9)	(10)	(11)	(12)
i)	No load										
ii)	Locked rotor										
iii)	Full load										

B-4.2.1 The drill runs up to full speed on no load in specified direction with V applied to stator.

B-4.2.2 Momentary overload (1.6 times) for 15 s. Tested

B-4.2.3 The drill has been tested as per IS 9192.

Tested by
Name
Signature and Date (Seal)

Accepted by
Name
Signature and Date (seal)

NOTE — For type testing complete form shall be filled up. For routing testing **B-4** to **B-4.2.3** shall not be filled up.

ANNEX C

(Foreword)

COMMITTEE COMPOSITION

Mining Techniques and Equipment Sectional Committee, MED 08

<i>Organization</i>	<i>Representative(s)</i>
Directorate General of Mines Safety, Dhanbad	SHRI SAIFULLAH ANSARI (Chairperson) SHRI M. ARUMUGAM (<i>Alternate</i>)
Andhra Pradesh Heavy Machinery and Engineering Limited, Vijaywada	SHRI T. V. RAMANA
BEML Limited, Bengaluru	SHRI V. R. S. PRASAD RAO SHRI H. G. SURESH (<i>Alternate</i>)
Bharat Coking Coal Limited, Dhanbad	SHRI P. K. SINHA
Caterpillar India Private Limited, Chennai	SHRI K. REJI JOSE
CSIR - Central Institute for Mining and Fuel Research, Dhanbad	DR MANOJ KUMAR SINGH SHRI SURAJIT DEY (<i>Alternate</i>) PROF S. K. KASHYAP (<i>Alternate</i>)
Eastern Coalfields Limited, Dishergarh	DR MANAS KUMAR
Eimco Elecon (India) Limited, Vallabh Vidyanagar	SHRI RAM RAMESH KALE SHRI VINAY JAYNARAYAN SHARMA (<i>Alternate</i>)
Hindustan Zinc Limited, Kolkata	SHRI B. V. RAO
Indian Institute of Technology (ISM), Dhanbad	SHRI L. A. KUMARASWAMIDHAS
John Deere India Private Limited, Mumbai	SHRI KARTHIK KALIAPPAN
Manganese Ore Limited, Nagpur	SHRI RAKESH KU. VERMA SHRI ATUL SHARMA (<i>Alternate I</i>) SHRI ASHWINI BAGHELE (<i>Alternate II</i>)
Nanda Millar Company, Kolkata	SHRI J. P. GOENKA SHRI MADHUR GOENKA (<i>Alternate</i>)
National Mineral Development Corporation, Hyderabad	SHRI D. RAJASEKARAN
South Eastern Coalfields Limited, Bilaspur	SHRI KAPIL K. RAI SHRI D. BHATTACHARJEE (<i>Alternate</i>)
Tata Steel Limited, Dhanbad	SHRI SOUMENDHU MANJHI SHRI ABINASH JHA (<i>Alternate</i>)
BIS Directorate General	SHRI NAVINDRA GAUTAM, SCIENTIST 'E'/DIRECTOR AND HEAD (MECHANICAL ENGINEERING) [REPRESENTING DIRECTOR GENERAL (<i>Ex-officio</i>)]

Member Secretary

SHRI SHUBHAM YADAV
SCIENTIST 'B'/ASSISTANT DIRECTOR
(MECHANICAL ENGINEERING), BIS

Bureau of Indian Standards

BIS is a statutory institution established under the *Bureau of Indian Standards Act, 2016* to promote harmonious development of the activities of standardization, marking and quality certification of goods and attending to connected matters in the country.

Copyright

BIS has the copyright of all its publications. No part of these publications may be reproduced in any form without the prior permission in writing of BIS. This does not preclude the free use, in the course of implementing the standard, of necessary details, such as symbols and sizes, type or grade designations. Enquiries relating to copyright be addressed to the Head (Publication & Sales), BIS.

Review of Indian Standards

Amendments are issued to standards as the need arises on the basis of comments. Standards are also reviewed periodically; a standard along with amendments is reaffirmed when such review indicates that no changes are needed; if the review indicates that changes are needed, it is taken up for revision. Users of Indian Standards should ascertain that they are in possession of the latest amendments or edition by referring to the website-www.bis.gov.in or www.standardsbis.in.

This Indian Standard has been developed from Doc No.: MED 08 (20486).

Amendments Issued Since Publication

Amend No.	Date of Issue	Text Affected

BUREAU OF INDIAN STANDARDS

Headquarters:

Manak Bhavan, 9 Bahadur Shah Zafar Marg, New Delhi 110002

Telephones: 2323 0131, 2323 3375, 2323 9402

Website: www.bis.gov.in

Regional Offices:

	Telephones
Central : 601/A, Konnectus Tower -1, 6 th Floor, DMRC Building, Bhavbhuti Marg, New Delhi 110002	{ 2323 7617
Eastern : 8 th Floor, Plot No 7/7 & 7/8, CP Block, Sector V, Salt Lake, Kolkata, West Bengal 700091	{ 2367 0012 2320 9474
Northern : Plot No. 4-A, Sector 27-B, Madhya Marg, Chandigarh 160019	{ 265 9930
Southern : C.I.T. Campus, IV Cross Road, Taramani, Chennai 600113	{ 2254 1442 2254 1216
Western : Plot No. E-9, Road No.-8, MIDC, Andheri (East), Mumbai 400093	{ 2821 8093

Branches : AHMEDABAD. BENGALURU. BHOPAL. BHUBANESHWAR. CHANDIGARH. CHENNAI. COIMBATORE. DEHRADUN. DELHI. FARIDABAD. GHAZIABAD. GUWAHATI. HIMACHAL PRADESH. HUBLI. HYDERABAD. JAIPUR. JAMMU & KASHMIR. JAMSHEDPUR. KOCHI. KOLKATA. LUCKNOW. MADURAI. MUMBAI. NAGPUR. NOIDA. PANIPAT. PATNA. PUNE. RAIPUR. RAJKOT. SURAT. VISAKHAPATNAM.