

भारतीय मानक

IS/IEC 63203-801-1 : 2022

Indian Standard

वेरबल इलेक्ट्रोनिक डिवाइसस एवं टेक्नॉलजीस

भाग 801 स्मार्ट बॉडी एरिया नेटवर्क (स्मार्टबीएन)

अनुभाग 1 एनहॅन्स्ड अल्ट्रा-लो पवर फिज़िकल लेयर

**Wearable Electronic Devices and
Technologies**

**Part 801 Smart Body Area Network
(SmartBAN)**

**Section 1 Enhanced Ultra-Low Power
Physical Layer**

ICS 35.100.01; 35.240.80

© BIS 2024

© ISO/IEC 2022



भारतीय मानक ब्यूरो

BUREAU OF INDIAN STANDARDS

मानक भवन, 9 बहादुर शाह ज़फर मार्ग, नई दिल्ली - 110002

MANAK BHAVAN, 9 BAHADUR SHAH ZAFAR MARG

NEW DELHI - 110002

www.bis.gov.in www.standardsbis.in

September 2024

Price Group 7

NATIONAL FOREWORD

This Indian Standard (Part 801/Sec 1) which is identical to IEC 63203-801-1 : 2022 'Wearable electronic devices and technologies — Part 801-1: Smart body area network (SmartBAN) — Enhanced ultra-low power physical layer' issued by the International Electrotechnical Commission (IEC) was adopted by the Bureau of Indian Standards on the recommendation of Wearable Electronic Devices and Technologies Sectional Committee and approval of the Electronics and Information Technology Division Council.

The text of IEC standard has been approved as suitable for publication as an Indian Standard without deviations. Certain conventions are, however, not identical to those used in Indian Standards. Attention is particularly drawn to the following:

- a) Wherever the words 'International Standard' appears referring to this standard, they should be read as 'Indian Standard'; and
- b) Comma (,) has been used as a decimal marker while in Indian Standards, the current practice is to use a point (.) as the decimal marker.

For the purpose of deciding whether a particular requirement of this standard is complied with, the final value, observed or calculated, expressing the result of a test or analysis, shall be rounded off in accordance with IS 2 : 2022 'Rules for rounding off numerical values (*second revision*)'. The number of significant places retained in the rounded off value should be same as that of the specified value in this standard

CONTENTS

INTRODUCTION.....	iv
1 Scope.....	1
2 Normative references.....	1
3 Terms and definitions.....	1
4 Abbreviated terms.....	1
5 General PHY framework – Frequency spectrum.....	2
6 Packet formats.....	2
6.1 PPDU structure.....	2
6.2 Preamble.....	3
6.3 Sync.....	3
6.4 PLCP header.....	3
6.4.1 PLCP header structure.....	3
6.4.2 Packet Length.....	3
6.4.3 PHY Scheme.....	3
6.4.4 BCH Parity Bits.....	3
6.4.5 Header Parity.....	3
6.5 PSDU.....	4
6.6 Frame parity.....	4
7 Modulation and error control.....	4
7.1 PPDU formation.....	4
7.2 Modulation.....	4
7.3 Repetition and FEC.....	5
7.3.1 Repetition.....	5
7.3.2 BCH (127, 113, $t = 2$) encoding.....	5
7.3.3 BCH (36, 22, $t = 2$) encoding.....	6
7.4 Scrambling.....	6
8 Other requirements.....	7
8.1 Packet length.....	7
8.2 CCA.....	8
Bibliography.....	9
Figure 1 – PPDU structure.....	3
Figure 2 – PLCP header structure.....	3
Figure 3 – Transmitter physical layer chain.....	4
Figure 4 – Example of 2-repetition and 4-repetition.....	5
Figure 5 – Data scrambler.....	6
Figure 6 – Channel access slot structure.....	7
Table 1 – Mapping of channel number to Data and Control Channel numbers.....	2
Table 2 – PHY scheme field bit mapping.....	4
Table 3 – PHY throughput.....	5

INTRODUCTION

TC 124 is developing International Standards (IS) for body area network (BAN) to define the wireless connectivity between the hub coordinator and the sensing nodes. The IEC 63203-801 series consists of the following sub-parts, under the general part title “Smart body area network (SmartBAN)”:

IEC 63203-801-1: Enhanced ultra-low power physical layer

IEC 63203-801-2: Low complexity medium access control (MAC) for SmartBAN

The present document describes the physical layer (PHY) specifications including packet formats, modulation and forward error correction.

This document originates from the corresponding technical specification (ETSI TS 103 326) standardized in the European Telecommunication Standard Institute (ETSI) and captures the results of the work of IEC TC 124 Working Group 4 on devices and systems. The current document reflects contributions and discussions by IEC TC 124 experts, mirror committees, liaison members and Joint Advisory Group (JAG) between IEC SyC AAL, IEC TC 100 and IEC TC 124. This document contains material gathered from reports and group output from the IEC TC 124 meetings in May 2018 (Manchester), October 2018 (Busan), May 2019 (San Francisco), September 2019 (Shanghai), November 2020 (online) as well as information obtained during various web meetings.

Experts from the following national committees, liaison organizations have contributed: BE, CN, DE, FI, FR, GB, IN, JP, KR, MY, NL, US and ETSI TC SmartBAN.

This document is also positioned as a result of the activities of the JAG. At the IEC General Meeting in Busan in 2018, three committees related to wearable systems and technologies, SyC AAL, IEC TC 100 and IEC TC 124 had a joint workshop and agreed to collaborate to develop relevant standards and to share roles. This collaboration agreement was made into a Joint Advisory Group (JAG) and the JAG was established and managed by SyC. AAL in 2019.

The target audience for this document includes the following stakeholders who have an interest in the systems and services using wearable devices:

- consumer electronics (CE) and information communications technology (ICT) device manufacturers;
- system integrators who want to utilize wearable device and technologies;
- service operators who are interested in the AAL systems and services;
- stakeholders who want to understand the technologies and requirements for wireless connectivity between wearable sensor nodes and hub coordinators.

*Indian Standard***WEARABLE ELECTRONIC DEVICES AND TECHNOLOGIES
PART 801 SMART BODY AREA NETWORK (SMARTBAN)
SECTION 1 ENHANCED ULTRA-LOW POWER PHYSICAL LAYER****1 Scope**

This part of IEC 63203-801 specifies the ultra-low power physical layer (PHY) of SmartBAN.

As the use of wearables and connected body sensor devices grows rapidly in the Internet of Things (IoT), wireless body area networks (BANs) facilitate the sharing of data in smart environments such as smart homes, smart life, etc. In specific areas of digital healthcare, wireless connectivity between the edge computing device or hub coordinator and the sensing nodes requires a standardized communication interface and protocols.

The present document describes the following physical layer (PHY) specifications:

- packet formats;
- modulation;
- forward error correction.

2 Normative references

There are no normative references in this document.

3 Terms and definitions

No terms and definitions are listed in this document.

ISO and IEC maintain terminological databases for use in standardization at the following addresses:

- IEC Electropedia: available at <https://www.electropedia.org/>
- ISO Online browsing platform: available at <https://www.iso.org/obp>

4 Abbreviated terms

ACK	Acknowledgement
BAN	Body area network
BCH	Bose-Chaudhuri-Hocquenghem
BT	Bandwidth-time
CCA	Clear channel assessment
CE	Consumer electronics
CRC	Cyclic redundancy check
ED	Energy detection
FEC	Forward error correction
GFSK	Gaussian frequency shift keying
ICT	Information communications technology

IFS	Inter-frame spacing
IoT	Internet of Things
ISM	Industrial, scientific and medical
MAC	Medium access control
MPDU	MAC protocol data unit
PHY	Physical layer
PLCP	Physical layer convergence protocol
PPDU	PHY protocol data unit
PSDU	Physical layer service data unit
Sync.	Synchronization

5 General PHY framework – Frequency spectrum

The frequency of operation shall fall between 2 401 MHz and 2 481 MHz. The channels shall be arranged in blocks of 2 MHz with centre frequencies:

$$f_c = 2\,402 \text{ MHz} + 2 \times n \text{ MHz, for } n = 0 \text{ to } 39$$

where

n is the channel number.

Table 1 shows the mapping of the channel number to the Data Channel number and the Control Channel number.

Table 1 – Mapping of channel number to Data and Control Channel numbers

Channel number	Centre frequency (MHz)	Channel type	Data Channel number	Control Channel number
0	2 402	Control		0
1	2 404	Data	0	
...		Data		
11	2 424	Data	10	
12	2 426	Control		1
13	2 428	Data	11	
...		Data		
38	2 478	Data	36	
39	2 480	Control		2

6 Packet formats

6.1 PPDU structure

Figure 1 shows the PPDU structure. The PPDU consists of Preamble, Synchronization (Sync.), PLCP Header, PSDU and Frame Parity.

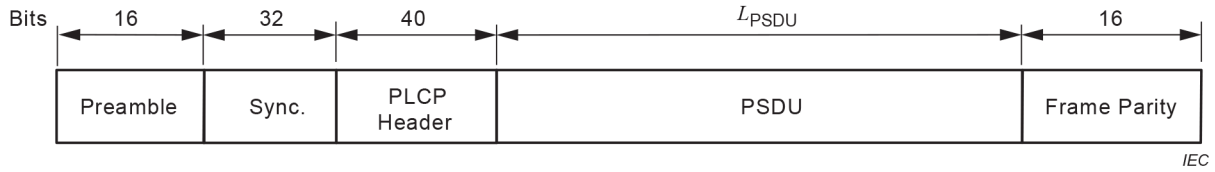

Figure 1 – PPDU structure

6.2 Preamble

PPDUs have a 16-bit preamble used for frequency synchronization, timing synchronization, and automatic gain control.

The preamble for all PPDUs shall be 1010101010101010.

6.3 Sync.

The Sync. field indicates the synchronization pattern that shall be 10000111101100101000011110110010.

6.4 PLCP header

6.4.1 PLCP header structure

The PLCP header is structured as illustrated in Figure 2. The PLCP header consists of Packet Length, PHY Scheme, Reserved, BCH Parity Bits, and the Header Parity fields.

The PLCP header may be scrambled by the procedure described in 7.4.

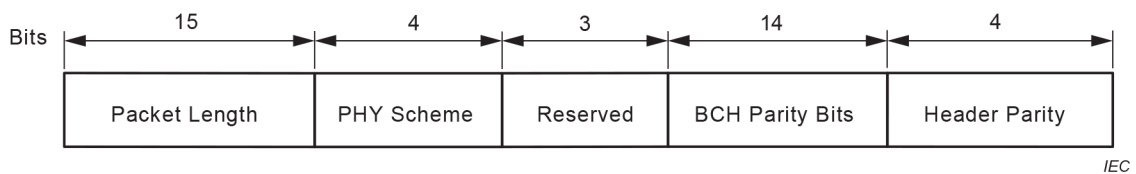

Figure 2 – PLCP header structure

6.4.2 Packet Length

The Packet Length field indicates the length of the PSDU.

6.4.3 PHY Scheme

The PHY Scheme field describes the forward error correction (FEC) type and the repetition type the PPDU employs. The mapping of the field bits is as described in Table 2.

6.4.4 BCH Parity Bits

The BCH Parity Bits field is generated using a BCH (36,22, $t = 2$) code defined in 7.3.3 to protect the Packet Length, PHY Scheme, and Reserved fields.

6.4.5 Header Parity

The Header Parity field is generated by the CRC polynomial $1 + x + x^4$ on the Packet Length, PHY Scheme, Reserved, and BCH Parity Bits fields.

Table 2 – PHY scheme field bit mapping

Field value b0 b1	FEC type		Field value b2 b3	Repetition type
00	None		00	None
01	BCH (127,113,2)		01	2
10	Reserved		10	4
11	Reserved		11	Reserved

6.5 PSDU

The physical layer service data unit (PSDU) is either an encoded or unencoded MAC protocol data unit (MPDU) as defined in IEC 63203-801-2:2022, 6.1. The MPDU may be encoded using a BCH (127,113, $t = 2$) code. The encoding procedure shall be described in 7.3. The PSDU shall be scrambled using the procedure described in 7.4.

6.6 Frame parity

The Frame Parity field shall contain a 16-bit CRC sequence of the PSDU generated using the generator polynomial $x^{16} + x^{12} + x^5 + 1$.

7 Modulation and error control

7.1 PPDU formation

The PPDU is formed from the following process described in Figure 3. The dashed boxes represent optional support.

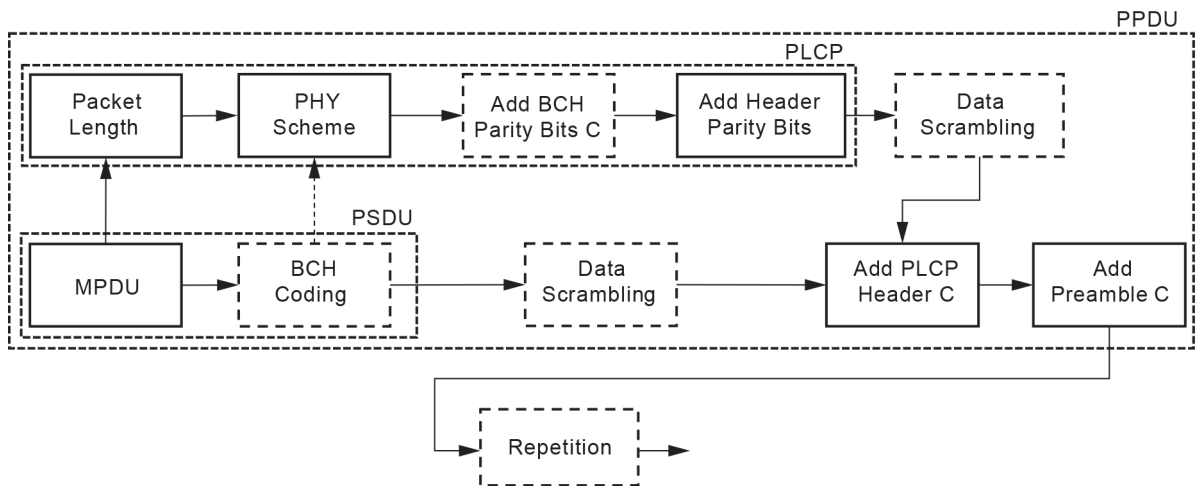

Figure 3 – Transmitter physical layer chain

7.2 Modulation

The modulation is Gaussian frequency shift keying (GFSK) with a bandwidth-time (BT) product that shall be 0,5, and a modulation index h that shall be 0,5.

A symbol rate, T_{sym} , of 1 MSymbols/s shall be supported in both control and data channels. Table 3 shows the possible information rate according to the combination of symbol rate, code rate and number of repetitions.

Table 3 – PHY throughput

Channel (data/control)	Information flow	Symbol rate (MSymbols/s)	Code rate	Repetition	Information rate (Mbps)
Data/control	Downlink/uplink	1,0	1	1	1,0
Data/control	Downlink/uplink	1,0	1	2	0,5
Data/control	Downlink/uplink	1,0	1	4	0,25
Data/control	Downlink/uplink	1,0	113/127	1	0,89
Data/control	Downlink/uplink	1,0	113/127	2	0,44
Data/control	Downlink/uplink	1,0	113/127	4	0,22

7.3 Repetition and FEC

7.3.1 Repetition

The hubs and nodes may implement repetition coding to reduce errors if required. Should repetition coding be implemented, this should be indicated in the PHY Scheme field in 6.4.3. Two repetition schemes should be supported, 2-repetition, repeating the entire PPDU two times, and 4-repetition, repeating the entire PPDU four times.

When repetition is employed, the original PPDU along with its repeated versions should be treated as one single PPDU.

An example of 2-repetition and 4-repetition is shown in Figure 4.

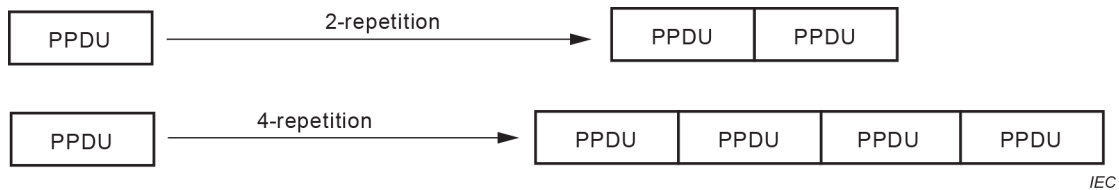

Figure 4 – Example of 2-repetition and 4-repetition

7.3.2 BCH (127,113, $t = 2$) encoding

For error correction control of the MPDU, a systematic BCH (127,113, $t = 2$) code may be employed. t indicates the maximum number of bits that can be corrected. The generator polynomial of the BCH (127,113, $t = 2$) code is

$$g(x) = x^{14} + x^9 + x^8 + x^6 + x^5 + x^4 + x^2 + x + 1 \quad (1)$$

The encoding process is as follows:

- 1) Calculate the number of padding bits, N_{padding} . The number of padding bits depends on the length of the MPDU, L_{MPDU} , and can be calculated as

$$N_{\text{padding}} = \left\lceil \frac{L_{\text{MPDU}}}{k} \right\rceil \times k - L_{\text{MPDU}} \quad (2)$$

where $k = 113$

- 2) Append $N_{padding}$ zero bits to the end of the MPDU.
- 3) Partition the padded MPDU into subpackets with a length of k .
- 4) Compute the parity bits for each subpackets using the generator polynomial $g(x)$.
- 5) Remove $N_{padding}$ bits from the last subpacket.
- 6) Append the parity bits generated for each subpacket to each subpacket.
- 7) Reassemble the expanded subpackets in the same order they were dissembled to produce the PSDU.

7.3.3 BCH (36, 22, $t = 2$) encoding

For error correction control of the Packet Length, PHY Scheme, and Reserved fields of the PLCP header, a systematic BCH (36,22, $t = 2$) code should be employed. The BCH code is a shortened code derived from the primitive BCH (127,113, $t = 2$) described in 7.3.2. The encoding process is as follows:

- 1) Set $N_{padding} = 91$.
- 2) Append $N_{padding}$ zero bits to the end of the Packet Length, PHY Scheme, and Reserved fields; the resulting 113 bits are treated as a subpacket in 7.3.2.
- 3) Compute the parity bits for the subpacket using the generator polynomial $g(x)$ in Formula (1).
- 4) Remove $N_{padding}$ bits from the subpacket.
- 5) Append the generated parity bits to the subpacket.

7.4 Scrambling

A data scrambler may be supported when necessary. The scrambling sequence generated by the scrambling polynomial is $1 + x^{14} + x^{15}$, with an initial state of 000100100001010. The output of the data scrambler is

$$x[n] = x[n - 14] \oplus x[n - 15] \tag{3}$$

Figure 5 shows an implementation of the data scrambler. D denotes the delay operation.

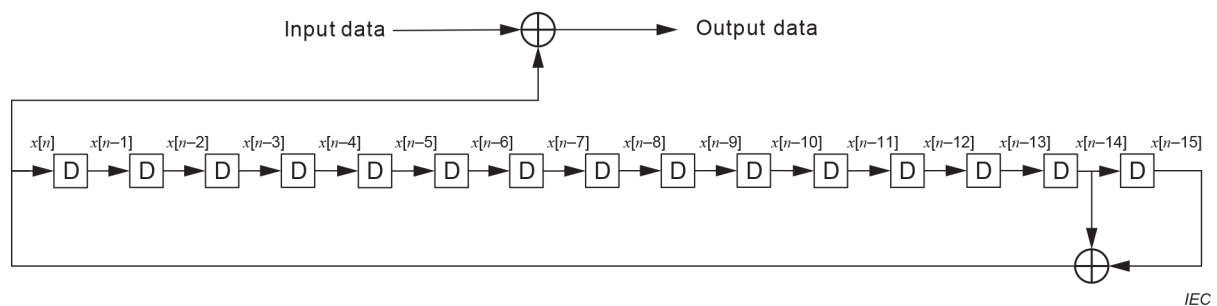

Figure 5 – Data scrambler

8 Other requirements

8.1 Packet length

In Clause 8, the maximum permitted length of PPDU and MPDU is calculated.

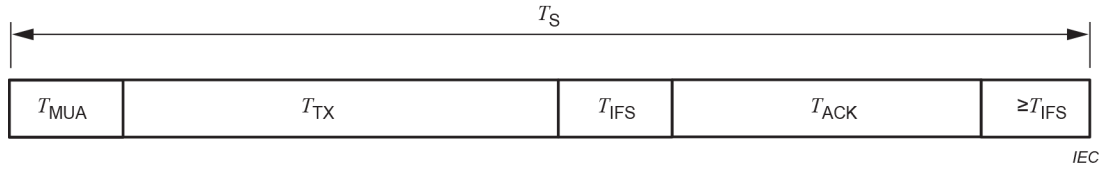

Figure 6 – Channel access slot structure

Each time slot is partitioned into two transmission phases (T_{TX} and T_{ACK}) and two or more transition phases (see Figure 6). The time allocated to the initial transmission phase is dependent on several factors:

- time for transmitting the acknowledgement frame;
- inter-frame spacing;
- channel access mode;
- PHY scheme.

The time for transmitting the acknowledgement frame is

$$T_{ACK} = (L_{\text{preamble}} + L_{\text{PLCPheader}} + L_{\text{header}} + L_{\text{parity}}) / R_{\text{sym}} \quad (4)$$

where L_{preamble} , $L_{\text{PLCPheader}}$, L_{header} , L_{parity} , and R_{sym} are the length (in bits) of the PHY preamble, PLCP header, MAC header, MAC parity fields, and the symbol rate respectively.

Therefore, the maximum permissible time for the initial transmission phase is

$$T_{TX,\text{max}} = (T_S - T_{MUA} - T_{ACK} - 2 \times T_{IFS}) / N_{\text{rep}} \quad (5)$$

where N_{rep} is the number of times the PPDU is repeated, as indicated in the PHY Scheme field in the PLCP header. T_{MUA} is the sensing time in the multi-use access mode. For scheduled and slotted Aloha channel access modes, T_{MUA} shall be 0. Consequently, the maximum length (in bits) of the PSDU is

$$L_{\text{PSDU,max}} = T_{TX,\text{max}} \times R_{\text{sym}} - (L_{\text{preamble}} + L_{\text{PLCPheader}}) \quad (6)$$

In the case where no BCH encoding is employed, $L_{\text{PSDU,max}} = L_{\text{MPDU,max}}$. When BCH (n, k) encoding is employed, the maximum length of the MPDU is

$$L_{\text{MPDU,max}} = \left[L_{\text{PSDU,max}} / n \right] \times k + \kappa \quad (7)$$

where

$$\kappa = \begin{cases} (L_{\text{PSDU,max}} \% n) - (n - k); & \text{if } (L_{\text{PSDU,max}} \% n) > (n - k), \\ 0; & \text{if } (L_{\text{PSDU,max}} \% n) < (n - k). \end{cases} \quad (8)$$

Hence, the maximum length of the MAC frame body, $L_{\text{F,max}}$ is

$$L_{\text{F,max}} = L_{\text{MPDU}} - L_{\text{header}} - L_{\text{parity}} \quad (9)$$

8.2 CCA

The PHY should provide the capability to perform clear channel assessment (CCA) in devices which optionally support the multi-use access channel access mode according to at least one of the following three methods:

- 1) CCA mode 1: Energy above the threshold. The CCA should report a busy medium upon detecting any energy above the energy detection (ED) threshold.
- 2) CCA mode 2: Carrier sense only. The CCA should report a busy medium only upon the detection of a signal compliant with the present document. This signal may be above or below the ED threshold. The CCA detection time shall be less than or equal to T_{MUA} .
- 3) CCA mode 3: Carrier sense with energy above the threshold. The CCA should report a busy medium using a logical combination of the following:
 - a) detection of a signal with the modulation and characteristics of the PHY that is currently in use by the device, and
 - b) energy above the ED threshold, where the logical operator can be AND or OR.

The CCA parameters are subject to the following criteria:

- The ED threshold should be -75 dBm.
- The CCA detection time should be less than or equal to T_{MUA} . Local regulatory requirements can apply for CCA procedures.

Bibliography

IEC 63203-801-2:2022, *Wearable electronic devices and technologies – Part 801-2: Smart body area network (SmartBAN) – Part 2: Low complexity medium access control (MAC) for SmartBAN*

ETSI TS 103 326, *Smart Body Area Network (SmartBAN); Enhanced Ultra-Low Power Physical Layer*, V1.2.1 (2021-07)

Bureau of Indian Standards

BIS is a statutory institution established under the *Bureau of Indian Standards Act, 2016* to promote harmonious development of the activities of standardization, marking and quality certification of goods and attending to connected matters in the country.

Copyright

BIS has the copyright of all its publications. No part of these publications may be reproduced in any form without the prior permission in writing of BIS. This does not preclude the free use, in the course of implementing the standard, of necessary details, such as symbols and sizes, type or grade designations. Enquiries relating to copyright be addressed to the Head (Publication & Sales), BIS.

Review of Indian Standards

Amendments are issued to standards as the need arises on the basis of comments. Standards are also reviewed periodically; a standard along with amendments is reaffirmed when such review indicates that no changes are needed; if the review indicates that changes are needed, it is taken up for revision. Users of Indian Standards should ascertain that they are in possession of the latest amendments or edition by referring to the website-www.bis.gov.in or www.standardsbis.in.

This Indian Standard has been developed from Doc No.: LITD 33 (24132).

Amendments Issued Since Publication

Amend No.	Date of Issue	Text Affected

BUREAU OF INDIAN STANDARDS

Headquarters:

Manak Bhavan, 9 Bahadur Shah Zafar Marg, New Delhi 110002

Telephones: 2323 0131, 2323 3375, 2323 9402

Website: www.bis.gov.in

Regional Offices:

Central : 601/A, Konnectus Tower -1, 6th Floor,
DMRC Building, Bhavbhuti Marg, New
Delhi 110002

Telephones

{ 2323 7617

Eastern : 8th Floor, Plot No 7/7 & 7/8, CP Block, Sector V,
Salt Lake, Kolkata, West Bengal 700091

{ 2367 0012
2320 9474

Northern : Plot No. 4-A, Sector 27-B, Madhya Marg,
Chandigarh 160019

{ 265 9930

Southern : C.I.T. Campus, IV Cross Road, Taramani, Chennai 600113

{ 2254 1442
2254 1216

Western : Manakalya, 4th Floor, NTH Complex (W Sector), F-10, MIDC, Andheri
(East), Mumbai 400093

{ 283 25838

Branches : AHMEDABAD, BENGALURU, BHOPAL, BHUBANESHWAR, CHANDIGARH, CHENNAI, COIMBATORE, DEHRADUN, DELHI, FARIDABAD, GHAZIABAD, GUWAHATI, HARYANA (CHANDIGARH), HUBLI, HYDERABAD, JAIPUR, JAMMU, JAMSHEDPUR, KOCHI, KOLKATA, LUCKNOW, MADURAI, MUMBAI, NAGPUR, NOIDA, PARWANOO, PATNA, PUNE, RAIPUR, RAJKOT, SURAT, VIJAYAWADA.