

मैनुअल रूप से संचालित उर्वरक  
प्रसारणकर्ता — विशिष्टि

( पहला पुनरीक्षण )

Manually Operated Fertilizer  
Broadcaster — Specification

( First Revision )

ICS 65.060.01

© BIS 2024



भारतीय मानक ब्यूरो  
BUREAU OF INDIAN STANDARDS  
मानक भवन, 9 बहादुर शाह ज़फर मार्ग, नई दिल्ली - 110002  
MANAK BHAVAN, 9 BAHADUR SHAH ZAFAR MARG  
NEW DELHI - 110002

[www.bis.gov.in](http://www.bis.gov.in) [www.standardsbis.in](http://www.standardsbis.in)

## FOREWORD

This Indian Standard (First Revision) was adopted by the Bureau of Indian Standards, after the draft finalized by the Agricultural Machinery and Equipment Sectional Committee had been approved by the Food and Agriculture Division Council.

Fertilizers are broadcasted in the field mostly by hand. But hand broadcasting is a time-consuming operation and also the distribution is not uniform. To overcome this issue, simple hand-operated fertilizer broadcasters were developed. As demand of these broadcasters increased among the farmers, a need was felt to develop a standard for the manufacturers to produce and users to select good quality fertilizer broadcasters. The standard was published in 1988 deriving assistance from technical information provided by Punjab Agricultural University, Ludhiana.

The revision of this standard has been brought out to incorporate necessary editorial corrections and to align it with latest style and format of Indian Standards. Amendment No. 1 issued to the earlier version has also been included. Reference to Indian Standards wherever applicable have been updated.

The figure given in the standard is meant only for illustration of components. This should not be considered as suggestive of any standard design.

The composition of the Committee responsible for the formulation of this standard is given in [Annex B](#).

For the purpose of deciding whether a particular requirement of this standard is complied with, the final value, observed or calculated, expressing the result of a test or analysis, shall be rounded off in accordance with IS 2 : 2022 'Rules for rounding off numerical values (*second revision*)'. The number of significant places retained in the rounded off value should be the same as that of the specified value in this standard.

*Indian Standard***MANUALLY OPERATED FERTILIZER BROADCASTER —  
SPECIFICATION***( First Revision )***1 SCOPE**

This standard prescribes the material, constructional and other requirements of manually operated fertilizer broadcaster.

**2 REFERENCES**

The standards listed in [Annex A](#) contain provisions which, through reference in this text, constitute provisions of this standard. At the time of publication, the edition indicated were valid. All standards are subject to revision, and parties to agreements based on this standard are encouraged to investigate the possibility of applying the most recent edition of these standards.

**3 TERMINOLOGY**

For the purpose of this standard, the following definitions shall apply (*see also* [Fig. 1](#)).

**3.1 Agitator** — A device which mechanically initiates the movement of the fertilizer within the hopper (*see* [Fig. 1](#)).

**3.2 Broadcasting** — The process of scattering of agricultural inputs, such as seed, fertilizer and manure on the surface of the soil.

**3.3 Crank** — A component to help in rotating the gear train.

**3.4 Feed Control** — A device to control the feed of the fertilizer.

**3.5 Fertilizer Broadcaster** — A fertilizer distributor with a spreading width substantially greater than the width of the machine.

**3.6 Hopper** — A container for holding the fertilizer.

**3.7 Spreading Disc** — A circular disc having equally spaced fins for spreading the material falling on the disc by centrifugal force.

**3.8 Total Mass** — The mass of the broadcaster with all its mountings and attachments but without any fertilizer in the hopper.

**4 MATERIAL**

**4.1** The materials for construction of various

components of manually operated fertilizer broadcasters are given in [Table 1](#) for guidance.

**4.2** The material used for different components shall be declared by the manufacturer in the parts catalogue (*see* [5.10](#)).

**5 CONSTRUCTIONAL REQUIREMENTS****5.1 Hopper**

The hopper shall have a concave shaped or conical bottom with a slope of 30° to 50° so that the fertilizer contained in it easily moves towards the feeding aperture. The hopper bottom shall have a circular hole for metering the fertilizer. The ratio between the diameter and the height of the hopper shall be in the range of 0.8 to 1.25. The hopper should be covered with a lid. The lid if provided, should have a peeping hole of at least 75 mm in diameter for observing the quantity of fertilizer left in the hopper during operation. The hopper should be sufficiently strong and should not buckle when fully filled with fertilizer.

The thickness of the mild steel and galvanized steel sheet for hopper shall be not less than 0.63 mm and 0.56 mm respectively.

**5.2 Spreading Disc**

The spreading disc mounted at the bottom of the hopper shall have 6 or 8 equally spaced fins. The spreading disc shall have a vertical clearance of at least 30 mm from the hopper bottom.

**5.3 Feed Control Mechanism**

A suitable feed control mechanism with locking device shall be provided to control the flow of fertilizer through the aperture. The mechanism shall be controlled by 8 levers from outside of the hopper and shall not require any tool for the operation. Provision of an Index pointer with marking for the aperture opening of hopper at positions closed 1/4, 1/2, 3/4 and full shall be provided. Provision of a scale indicating the discharge rate in kg/ha at different settings of the aperture opening is preferred.

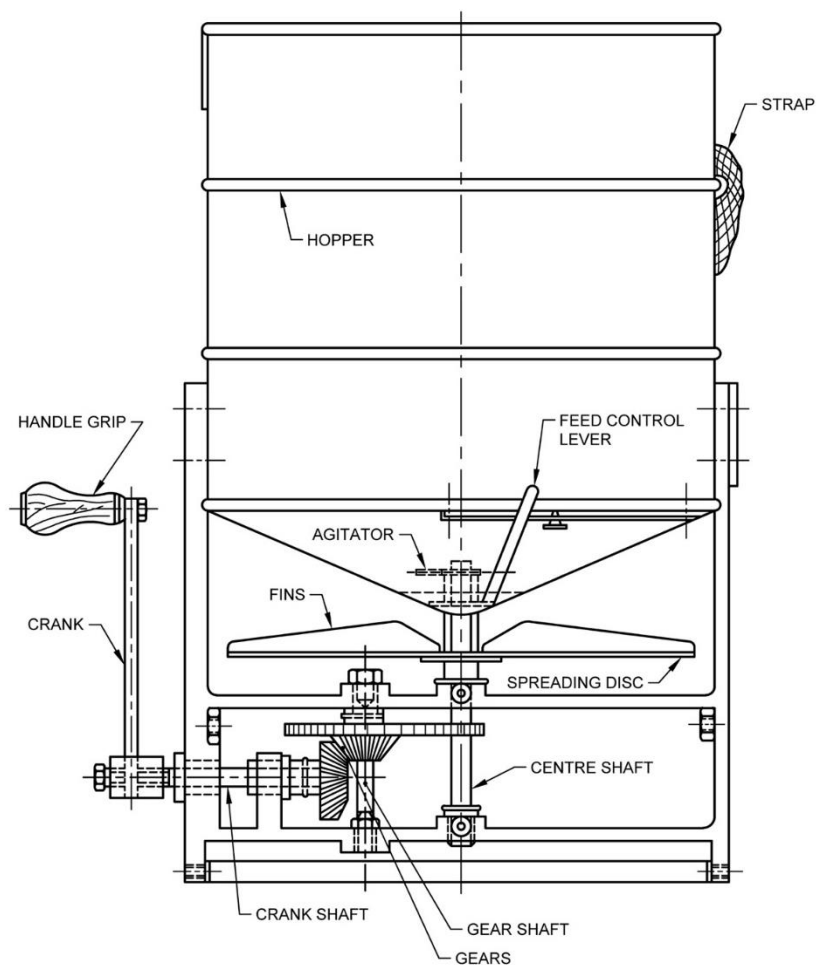

FIG. 1 NOMENCLATURE OF A MANUALLY OPERATED FERTILIZER BROADCASTER

**Table 1 Material for Construction of Different Components**

*(Clause 4.1)*

Sl No.	Name of Component	Material	Refer to Indian Standard
(1)	(2)	(3)	(4)
i)	Hopper	Mild steel	IS 2062
		Galvanized steel sheet	IS 277
		Aluminium	IS 617
		Fibre glass reinforcement plastics	-
		Plastics	-
ii)	Spreading disc	Plastics	-
iii)	Lid	Plastics	-
iv)	Handle grip	Seasoned wood	IS 620
		Plastics	-
v)	Gears	Mild steel	IS 2062
		Nylon	-
vi)	Agitators	Mild steel	IS 2062
		Spring steel	IS 4454 (Part 2)

Sl No.	Name of Component	Material	Refer to Indian Standard
(1)	(2)	(3)	(4)
vii)	Gear shaft	Mild steel	IS 2062
		Carbon steel	IS 5517
viii)	Centre shaft	Carbon steel	IS 5517
ix)	Crank shaft	Mild steel	IS 2062
x)	Feed control mechanism	Mild steel	IS 2062
		Galvanized steel sheet	IS 277
		Nylon	-
xi)	Strap	Woven web cotton	-
		Synthetic yarn	-

#### 5.4 Agitator

A suitable agitator shall be provided near the orifice of the hopper to avoid the clogging of the aperture and for feeding the fertilizer to the aperture. The agitator shall be kept at a vertical clearance of at least 3 mm above the aperture.

#### 5.5 Gear Box and Gears

A suitable gear arrangement shall be provided for giving a peripheral speed of 500 cm/s  $\pm$  50 cm/s to the spreading disc. The gear box shall be so designed as to allow easy access to gears for lubricating and inspection. Suitable provision for lubrication shall be provided. The gears shall mate correctly and shall move smoothly.

#### 5.6 Crank

A crank shall be fitted with the crank shaft which should function in a clockwise motion. The crank shall be fitted with a handle of sufficient size. The handle shall be in easy reach of the operator.

#### 5.7 Straps

**5.7.1** Two straps of suitable length shall be provided in order to help easy carriage of the broadcaster. The provision for easy adjustment of the length of the straps shall be provided. At the option of the purchaser, a cushion of minimum 40 mm width and 20 mm thickness shall be provided with the straps at least on that portion which rests on the shoulder of the operator. The cushion, if provided shall be covered with cotton, canvas, rexin, PVC or plastic-coated fabrics. The straps and their assembly shall withstand the test prescribed in [5.7.2](#).

**5.7.2** The hopper shall be filled with granular fertilizer to its total capacity. The broadcaster shall be hung from a solid support by its straps, simulating its carriage by the operator. It shall be lifted to a

height of 30 cm and allowed to drop and hang by straps 25 times. The straps and their assembly shall be deemed to have passed this test, if no breakage, deformation, etc are found during the test.

#### 5.8 Bearings

The crank shaft, gear shaft and the centre shaft shall be provided with bearings. The bearings shall be dust proof.

#### 5.9 Total Mass

The total mass of the broadcaster shall not exceed 5 kg (*see* [3.8](#)).

#### 5.10 Other Requirements

**5.10.1** Operational and maintenance manual and parts catalogue shall be provided with each broadcaster. The manual should also contain the safety precautions, recommended forward speed, handle speed, effective width of spread, calibration chart indicating the discharge rate in kg/ha at different settings of the aperture opening, etc.

**5.10.2** Each broadcaster shall also be supplied with necessary tools.

### 6 CAPACITY

The total capacity of the hopper shall be 12 litre to 15 litre. The capacity shall be declared by the manufacturer. The tolerance on the declared capacity shall be  $\pm$  5 percent.

### 7 WORKMANSHIP AND FINISH

**7.1** The components of the broadcaster shall have a smooth finish and shall be free from pits, burrs. Sharp edges and other defects that may be detrimental for their use.

7.2 The exposed metallic parts shall have a protective coating to prevent surface deterioration in transit and storage.

## 8 MARKING AND PACKING

### 8.1 Marking

Each broadcaster shall be marked with the following particulars:

- a) Manufacturer's name or recognized trademark, if any;
- b) Batch or code number; and
- c) Hopper capacity.

### 8.2 BIS Certification Marking

The product(s) conforming to the requirements of this standard may be certified as per the conformity assessment schemes under the provisions of the *Bureau of Indian Standards Act, 2016* and the Rules

and Regulations framed thereunder, and the products may be marked with the Standard Mark.

### 8.3 Packing

Each broadcaster shall be packed, as agreed to between the purchaser and the supplier, for safe handling in transit.

## 9 SAMPLING FOR LOT ACCEPTANCE

Unless otherwise agreed to between the purchaser and the supplier, sampling of the broadcaster for lot acceptance shall be done in accordance with **3** of IS 7201 (Part 1). The classification of different requirements of this specification for the purpose of lot acceptance is given below for guidance:

- a) Dimensional and visual requirements — see [5](#) (except [5.7.2](#) and [5.9](#)); and
- b) Other than visual and dimensional requirements — see [5.7.2](#), [5.9](#) and [6](#).

## ANNEX A

*(Clause 2)*

## LIST OF REFERRED STANDARDS

<i>IS No.</i>	<i>Title</i>	<i>IS No.</i>	<i>Title</i>
IS 277 : 2018	Galvanized steel strips and sheets (plain and corrugated) — Specification ( <i>seventh revision</i> )	IS 4454 (Part 2) : 2001	Steel wire for mechanical springs — Specification: Part 2 Oil hardened and tempered steel wire ( <i>second revision</i> )
IS 617 : 2024	Aluminium and aluminium alloys ingots for remelting and castings for general engineering purposes — Specification ( <i>fourth revision</i> )	IS 5517 : 1993	Steels for hardening and tempering — Specification ( <i>second revision</i> )
IS 620 : 1985	Specification for wooden tool handles general requirements ( <i>fourth revision</i> )	IS 7201 (Part 1) : 1987	Methods of sampling for agricultural machinery and equipment: Part 1 Hand-tools and hand-operated/animal-drawn equipment ( <i>first revision</i> )
IS 2062 : 2011	Hot rolled medium and high tensile structural steel — Specification ( <i>seventh revision</i> )		

To access Indian Standards click on the link below:

[https://www.services.bis.gov.in/php/BIS\\_2.0/bisconnect/knowyourstandards/Indian\\_standards/isdetails/](https://www.services.bis.gov.in/php/BIS_2.0/bisconnect/knowyourstandards/Indian_standards/isdetails/)

## ANNEX B

*(Foreword)*

## COMMITTEE COMPOSITION

Agricultural Machinery and Equipment Sectional Committee, FAD 11

<i>Organization</i>	<i>Representative(s)</i>
ICAR - Central Institute of Agricultural Engineering, Bhopal	DR C. R. MEHTA ( <i>Chairperson</i> )
Agricultural Machinery Manufacturers Association (AMMA-India), Gandhinagar	DR SURENDRA SINGH SHRI MITUL PANCHAL ( <i>Alternate</i> )
All India Farmers Alliance, New Delhi	DR RAJARAM TRIPATHI SHRIMATI APURVA TRIPATHI ( <i>Alternate</i> )
ASPEE Agro Equipment Private Limited, Mumbai	SHRI JATIN S. PATEL SHRI GANGADHAR VARPE ( <i>Alternate</i> )
Automotive Research Association of India, Pune	SHRI A. AKBAR BADUSHA SHRI GIRISH TANAWADE ( <i>Alternate I</i> ) SHRI GANGARAM AUTI ( <i>Alternate II</i> )
CCS Haryana Agricultural University, Hisar	DR VIJAYA RANI
Central Farm Machinery Training and Testing Institute, Budni	SHRI ANIL KUMAR UPADHYAY SHRI BABUL NATH DIXIT ( <i>Alternate I</i> ) SHRI PARTH LODH ( <i>Alternate II</i> )
CLAAS India Private Limited, Chandigarh	SHRI KRISHNA PRABHAKAR SINGH
CNH Industrial India Private Limited, Pune	SHRI SANTHOSH RAO SHRI SUJIT HINGE ( <i>Alternate</i> )
Consumer Guidance Society of India, Mumbai	SHRI SITARAM DIXIT
Dasmesh Mechanical Works Private Limited, Malerkotla	SHRI SARBJEET SINGH PANESAR SHRI GURDEEP SINGH PANESAR ( <i>Alternate</i> )
ICAR - All India Coordinated Research Project on Ergonomics and Safety in Agriculture, Bhopal	DR SUKHBIR SINGH DR RAHUL R. POTDAR ( <i>Alternate I</i> ) SHRIMATI SWEETI KUMARI ( <i>Alternate II</i> )
ICAR - All India Coordinated Research Project on Farm Implements and Machinery, Bhopal	DR K. N. AGRAWAL
ICAR - All India Coordinated Research Project on Mechanization of Animal Husbandry, Bhopal	DR S. P. SINGH
ICAR - Central Institute of Agricultural Engineering, Bhopal	DR V. P. CHAUDHARY DR U. R. BADEGAONKAR ( <i>Alternate I</i> ) DR DILIP JAT ( <i>Alternate II</i> )
Indian Council of Agricultural Research, New Delhi	DR PANNA LAL SINGH
John Deere India Private Limited, Pune	SHRI ANAND RAJ SHRI CHANDRASHEKHAR DESHMUKH ( <i>Alternate I</i> ) SHRI PRATIK DURAPHE ( <i>Alternate II</i> )
Kerala Agro Machinery Corporation Ltd (KAMCO), Athani	SHRI A. UNNIKRISHNAN SHRI P. C. SAJIMON ( <i>Alternate</i> )
Kisan Kraft Limited, Bangaluru	SHRI RAVINDRA AGARWAL SHRI ANKIT CHITALIA ( <i>Alternate I</i> ) SHRI SUNIL PRASAD ( <i>Alternate II</i> )



<i>Organization</i>	<i>Representative(s)</i>
Kubota Agricultural Machinery India Private Limited, Faridabad	SHRI ASHOK KUMAR SHRI ASHISH KUMAR MALLARH ( <i>Alternate</i> )
Maharana Pratap University of Agricultural and Technology, Udaipur	DR SANWAL SINGH MEENA
Mahatma Phule Krishi Vidyapeeth, Rahuri	DR SACHIN MADHUKAR NALAWADE SHRI VIKRAM PARASHARAM KAD ( <i>Alternate I</i> ) DR AVDHUT ASHOK WALUN ( <i>Alternate II</i> )
Mahindra and Mahindra Limited, Mumbai	SHRI PRADEEP SHINDE
Ministry of Agriculture, Department of Agriculture, New Delhi	DR V. N. KALE SHRI ARVIND N. MESHARAM ( <i>Alternate</i> )
National Innovation Foundation, New Delhi	SHRI RAKESH MAHESHWARI SHRI MAHESH PATEL ( <i>Alternate</i> )
National Institute of Plant Health Management, Hyderabad	DR VIDHU KAMPURATH P. SHRI MUTYALA UDAYA ( <i>Alternate</i> )
North Eastern Region Farm Machinery Training and Testing Institute, Biswanath Chariali	DR P. P. RAO SHRI S. G. PAWAR ( <i>Alternate I</i> ) SHRI KHAGENDRA BORA ( <i>Alternate II</i> )
Northern Region Farm Machinery Training and Testing Institute, Hisar	DR MUKESH JAIN SHRI SANJAY KUMAR ( <i>Alternate</i> )
Power Tillers Manufacturers Association, Kolkata	SHRI A. R. GANESH KUMAR
Punjab Agricultural University, Ludhiana	DR MAHESH KUMAR NARANG DR RAJESH GOYAL ( <i>Alternate I</i> ) SHRI APOORV PRAKASH ( <i>Alternate II</i> )
Southern Region Farm Machinery Training and Testing Institute, Anantpur	DR B. M. NANDEDE
Tamil Nadu Agricultural University, Coimbatore	DR R. KAVITHA DR A. SURENDRA KUMAR ( <i>Alternate I</i> ) DR A. P. MOHAN KUMAR ( <i>Alternate II</i> )
Tirth Agro Technology Pvt. Ltd. 'Shaktiman', Rajkot	SHRI PARAG DEVIDAS BADGUJAR SHRI V. AUDHI NARAYAN REDDY ( <i>Alternate</i> )
Tractor and Mechanization Association, New Delhi	SHRI PHILIP KOSHY SHRI VEENIT NEGI ( <i>Alternate I</i> ) SHRIMATI DEVYANI ( <i>Alternate II</i> )
Tube Investments Clean Mobility Private Limited, Chennai	SHRI ABHISHEK SINHA SHRI S. O. TYAGI ( <i>Alternate</i> )
Voluntary Organisation in Interest of Consumer Education (VOICE), New Delhi	SHRI B. K. MUKHOPADHYAY
In Personal Capacity Capacity (201, Memnon Tower, Omaxe The Nile, Sector 49, Sohna Road, Gurugram - 122018)	SHRI VIVEK GUPTA
BIS Directorate General	SHRIMATI SUNEETI TOTEJA, SCIENTIST 'F'/SENIOR DIRECTOR AND HEAD (FOOD AND AGRICULTURE) [REPRESENTING DIRECTOR GENERAL ( <i>Ex-officio</i> )]

*Member Secretary*  
SHRI VIKRANT CHAUHAN  
SCIENTIST 'B'/ASSISTANT DIRECTOR  
(FOOD AND AGRICULTURE), BIS

**IS 12337 : 2024**

Panel to review and formulate Indian Standards on Plant Protection Equipment, FAD 11/P 8

<i>Organization</i>	<i>Representative(s)</i>
ICAR - Central Institute of Agricultural Engineering, Bhopal	DR K. N. AGRAWAL ( <b>Convenor</b> )
Agricultural Machinery Manufacturers Association (AMMA-India), Gandhinagar	DR SURENDRA SINGH
ASPEE Agro Equipment Private Limited, Mumbai	SHRI JATIN S. PATEL
Dr. Balasaheb Sawant Konkan Krishi Vidyapeeth, Dapoli	DR P. U. SHAHARE
John Deere India Private Limited, Pune	SHRI CHANDRASHEKHAR DESHMUKH
Ministry of Agriculture, Department of Agriculture, New Delhi	SHRI ARVIND N. MESHRAM
National Institute of Plant Health Management, Hyderabad	DR VIDHU KAMPURATH P.
Northern Region Farm Machinery Training and Testing Institute, Hisar	DR MUKESH JAIN
Punjab Agricultural University, Ludhiana	DR MAHESH KUMAR NARANG
Southern Region Farm Machinery Training and Testing Institute, Anantpur	DR B. M. NANDEDE



## Bureau of Indian Standards

BIS is a statutory institution established under the *Bureau of Indian Standards Act, 2016* to promote harmonious development of the activities of standardization, marking and quality certification of goods and attending to connected matters in the country.

### Copyright

BIS has the copyright of all its publications. No part of these publications may be reproduced in any form without the prior permission in writing of BIS. This does not preclude the free use, in the course of implementing the standard, of necessary details, such as symbols and sizes, type or grade designations. Enquiries relating to copyright be addressed to the Head (Publication & Sales), BIS.

### Review of Indian Standards

Amendments are issued to standards as the need arises on the basis of comments. Standards are also reviewed periodically; a standard along with amendments is reaffirmed when such review indicates that no changes are needed; if the review indicates that changes are needed, it is taken up for revision. Users of Indian Standards should ascertain that they are in possession of the latest amendments or edition by referring to the website-[www.bis.gov.in](http://www.bis.gov.in) or [www.standardsbis.in](http://www.standardsbis.in).

This Indian Standard has been developed from Doc No.: FAD 11 (25122).

### Amendments Issued Since Publication

Amend No.	Date of Issue	Text Affected

## BUREAU OF INDIAN STANDARDS

### Headquarters:

Manak Bhavan, 9 Bahadur Shah Zafar Marg, New Delhi 110002

Telephones: 2323 0131, 2323 3375, 2323 9402

Website: [www.bis.gov.in](http://www.bis.gov.in)

### Regional Offices:

	Telephones
Central : 601/A, Konnectus Tower -1, 6 <sup>th</sup> Floor, DMRC Building, Bhavbhuti Marg, New Delhi 110002	{ 2323 7617
Eastern : 8 <sup>th</sup> Floor, Plot No 7/7 & 7/8, CP Block, Sector V, Salt Lake, Kolkata, West Bengal 700091	{ 2367 0012 2320 9474
Northern : Plot No. 4-A, Sector 27-B, Madhya Marg, Chandigarh 160019	{ 265 9930
Southern : C.I.T. Campus, IV Cross Road, Taramani, Chennai 600113	{ 2254 1442 2254 1216
Western : 5 <sup>th</sup> Floor/MTNL CETTM Technology Street, Hiranandani Gardens, Powai, Mumbai - 400076	{ 25700030 25702715

**Branches :** AHMEDABAD, BENGALURU, BHOPAL, BHUBANESHWAR, CHANDIGARH, CHENNAI, COIMBATORE, DEHRADUN, DELHI, FARIDABAD, GHAZIABAD, GUWAHATI, HARYANA (CHANDIGARH), HUBLI, HYDERABAD, JAIPUR, JAMMU, JAMSHEDPUR, KOCHI, KOLKATA, LUCKNOW, MADURAI, MUMBAI, NAGPUR, NOIDA, PARWANOO, PATNA, PUNE, RAIPUR, RAJKOT, SURAT, VIJAYAWADA.