

फसल संरक्षण उपकरण — रॉकर फुहारा —
विशिष्टि और परिक्षण पद्धति
(पाँचवां पुनरीक्षण)

Crop Protection Equipment —
Rocker Sprayer — Specification
and Test Method
(Fifth Revision)

ICS 65.060.40

© BIS 2024



भारतीय मानक ब्यूरो
BUREAU OF INDIAN STANDARDS
मानक भवन, 9 बहादुर शाह ज़फर मार्ग, नई दिल्ली - 110002
MANAK BHAVAN, 9 BAHADUR SHAH ZAFAR MARG
NEW DELHI - 110002
www.bis.gov.in www.standardsbis.in

July 2024

Price Group 12

FOREWORD

This Indian Standard (Fifth Revision) was adopted by the Bureau of Indian Standards, after the draft finalized by the Agricultural Machinery and Equipment Sectional Committee had been approved by the Food and Agriculture Division Council.

This standard was first published in 1965 and subsequently revised in 1970, 1974 and 1982. A need was felt again to revise the standard to incorporate certain technical modifications as suggested by the testing centres and the manufacturers. The fourth revision was done in the year 1995, whereby, materials of construction were modified and chemical composition of brass casting components as per relevant Indian Standards were given to ensure conformity, provision of supply of adjustable hydraulic spray nozzle and spray gun were given. Also, test for piston made of synthetic rubber was added.

In this revision the following modifications have been made:

- a) Technical data has been elaborated and explained through respective figures and clauses;
- b) Performance test methods and test for components have been incorporated which were earlier covered in IS 10134 : 1994 'Methods of test for manually-operated sprayers (*first revision*)';
- c) Addition of further details as [Annex D](#) (hand operated cut-off device), [Annex E](#) (spray lance), [Annex F](#) (hydraulic spray gun) and [Annex G](#) (hydraulic spray nozzle) has been made which were earlier covered in IS 3652 : 1995 'Crop protection equipment — Foot sprayer — Specification (*fourth revision*)';
- d) Option of multihole nozzle is also provided; and
- e) Necessary editorial changes have been made including updating of referred Indian Standards and schematic diagrams given in the standard.

The figures given in the standard are meant only for illustration of the components. These should not be considered as suggestive of any standard design.

This standard contains [9.3](#) which call for agreement between the purchaser and the supplier. For the guidance of the purchaser and testing centres information to be supplied by the manufacturer is given in [Annex B](#).

The composition of the Committee responsible for the formulation of this standard is given in [Annex H](#).

For the purpose of deciding whether a particular requirement of this standard is complied with, the final value, observed or calculated, expressing the result of a test or analysis, shall be rounded off in accordance with IS 2 : 2022 'Rules for rounding off numerical values (*second revision*)'. The number of significant places retained in the rounded off value should be the same as that of the specified value in this standard.

*Indian Standard***CROP PROTECTION EQUIPMENT — ROCKER SPRAYER —
SPECIFICATION AND TEST METHOD***(Fifth Revision)***1 SCOPE**

This standard specifies material, performance, constructional and other requirements of rocker sprayer (rocker type mechanical device) used for spraying pesticides.

The sprayers of this type are normally used with an average working pressure of 600 kPa (100 kPa = 1.019 7 kgf/cm² = 1 bar).

2 REFERENCES

The standards listed in [Annex A](#) contain provisions which through reference in this text, constitute provisions of this standard. At the time of publication, the editions indicated were valid. All standards are subject to revision and parties to agreements based on this standard are encouraged to investigate the possibility of applying the most recent edition of these standards.

3 TERMINOLOGY

For the purpose of this standard, the following definitions in addition to those given in IS 8480 shall apply (*see also* [Fig. 1](#) and [Fig. 2](#))

3.1 Handle Extension — A rod or tube, one end of which is attached to the handle lever to enable the sprayer to be operated with hand while the sprayer itself remains on the ground.

3.2 Handle Lever — A lever, connecting the handle extension, piston rod and frame to operate the piston with hand.

3.3 Handle Lever Pivot — A pivot for connecting the handle lever with frame.

3.4 Stroke — The maximum travel of the piston rod in one direction when the handle lever moves from a maximum of 25° forward to a maximum of 35° backward (that is, total of 60° or less), a vertical plane passing through the central line of the handle lever pivot.

3.5 Total Mass — The mass of complete sprayer with all its mountings but without any liquid and

discharge line, that is, without delivery hose, cut-off device, lance and nozzle.

3.6 Valve Assembly — A device provided to check or to allow the flow of the fluid.

4 MATERIALS

4.1 The material of construction of various components of the sprayer shall be selected from col (3) of [Table 1](#). The brass casting components shall conform to chemical composition of IS 292 (grade to be declared by the manufacturer). The material other than brass casting may conform to the relevant Indian Standards. Some of the relevant Indian Standards are given in [Annex C](#) for guidance.

4.2 The material for spray lance, nozzle, cut-off device, spray gun and its components shall be as given in [Table 1](#).

4.3 All metallic parts coming in contact with the pesticides should preferably be of the same material to minimize bimetallic corrosion.

4.4 The material used for different components shall be declared by the manufacturer in the manual (*see* [7.1](#)).

5 PERFORMANCE REQUIREMENTS**5.1 Discharge Rate**

When tested in accordance with the method give in [11.1](#). The pump shall be capable of discharging a minimum of 1 200 ml of water per minute.

5.2 Volumetric Efficiency

When tested in accordance with the method given in [11.2](#), the volumetric efficiency shall not be less than 82 percent.

5.3 Endurance Test

The sprayer shall withstand the test prescribed in [11.3](#).

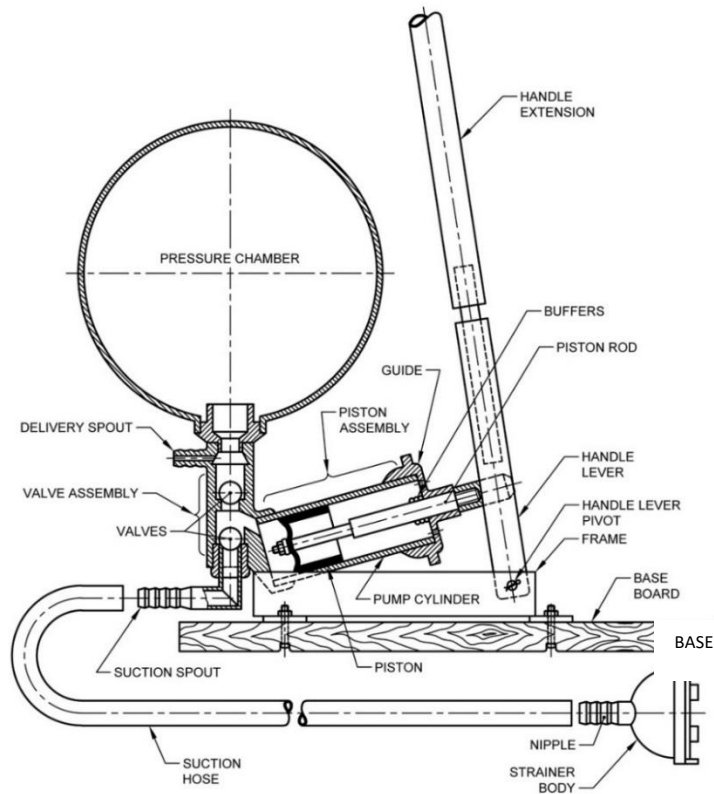

FIG. 1 ROCKER SPRAYER

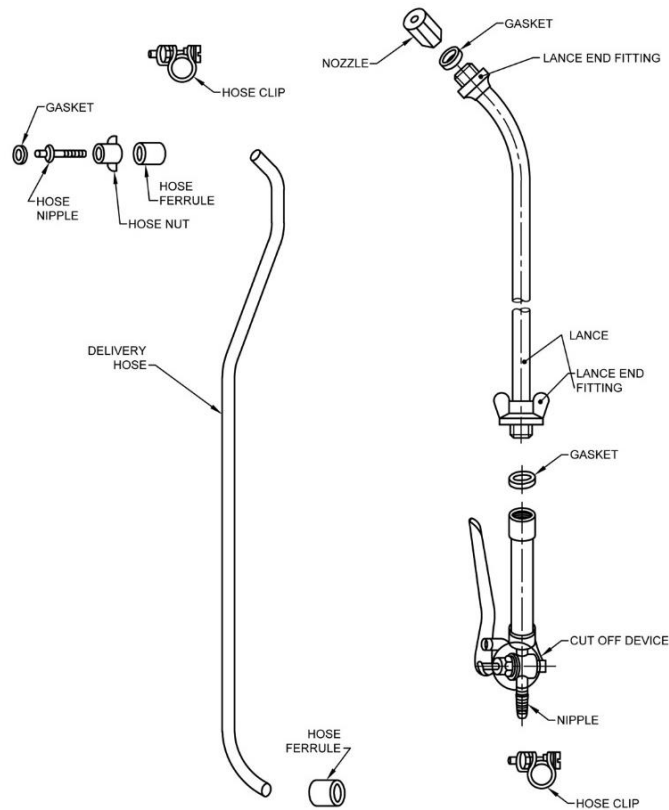

FIG. 2 DISCHARGE LINE OF SPRAYER

Table 1 Materials of Construction of Various Components*(Clauses 4.1 and 4.2)*

SI No.	Component	Material
(1)	(2)	(3)
i)	Pressure chamber, pump cylinder, piston rod, guide, suction spout, delivery spout, valve seat, spreader	Brass, stainless steel
ii)	Piston rod, valve	Brass, stainless steel, steel
iii)	Hose nut	Brass, stainless steel, engineering plastic
iv)	Hose nipple, strainer body	Brass, stainless steel, engineering plastic
v)	Strainer	Brass, stainless steel, engineering plastic
vi)	Frame, handle extension, handle lever	Steel
vii)	Hose ferrule/clip	Brass, steel
viii)	Base	Wood, plastic
ix)	Piston	Chrome tanned leather , PVC
x)	Buffer	Spring steel, engineering plastic, rubber
xi)	Hose	PVC
xii)	Gasket	Synthetic rubber, PVC, fibre
xiii)	Spray lance	Brass plastic, stainless steel
xiv)	Nozzle components	
	a) Body and cap	Brass, engineering plastic, stainless steel
	b) Swirl core	Brass, engineering plastic stainless steel,
	c) Disc tip	Brass, ceramic, stainless steel
	d) Spindle, coupling nut and gland nut	Brass, engineering plastic, stainless steel
	f) Strainer	Plastic, stainless steel
xv)	Cut off device components	
	a) Body, valve stem, valve seat, gland nut, cap and collar, nipple	Brass, engineering plastic, stainless steel
	b) Valve	Brass, synthetic rubber, stainless steel, engineering plastic
	c) Strainer	Brass, stainless steel, plastic
	d) Operating knob/lever	Brass, engineering plastic
	e) Operating trigger	Stainless steel, engineering plastic, steel
	f) Spring	Stainless steel
	g) Gasket	Synthetic rubber, fibre, PVC
	h) Gland seal	PVC
	j) Gland packing	Asbestos rope, PVC washer

Table 1 (Concluded)

SI No.	Component	Material
(1)	(2)	(3)
xvi)	Spray gun components	
	a) Barrel, connecting rod, connecting guide, connections for extension, holder and inlet collector, lock nut, gland nut and rigid washer	Brass, engineering plastic, stainless steel
	b) Swirl rotor, nozzle cap and body	Brass, engineering plastic, stainless steel
	c) Spring	Stainless steel
	d) Nozzle disc	Brass, stainless steel, ceramic
	e) Grip	Engineering plastic
	f) Packing gland	Asbestos rope, PVC washer, rubber
	g) Gland seal	PVC
	h) Split pin/pivot pin	Steel

NOTES

1 All the components mentioned above may not be available in a particular design.

2 The components other than those listed in above table and coming in direct contact with the pesticides shall be of corrosion resistant material.

6 CONSTRUCTIONAL REQUIREMENTS

6.1 Base

The length, width and thickness of the base shall be 750 mm to 900 mm, 140 mm to 220 mm and 20 mm to 30 mm respectively. Provision shall be made on base for fixing the frame.

6.2 Frame

It shall withstand the test prescribed in [12.1](#).

6.3 Handle Lever and Extension

The height of the handle lever with extension shall not be less than one meter when measured vertically from the base of the frame. The grip portion of the lever or extension shall be 25 mm to 30 mm in diameter. For slippery handles, handle grip shall be provided. The diameter of the handle with handle grip shall be between 32 mm to 35 mm.

6.3.1 The lever or extension shall not foul with any part of the sprayer. The angular movement of the handle lever and extension shall not be more than 25° forward to a maximum of 35° backward (that is, total of 60° or less) from a vertical plane passing through the central line of the handle lever pivot.

6.3.2 The handle lever and extension shall withstand the test prescribed in [12.1](#).

6.4 Pump

Pump shall conform to the requirement as given in [6.4.1](#) to [6.4.5](#).

6.4.1 Pump Cylinder

It shall not be more than 55 mm in inner diameter and shall withstand the test prescribed in [12.2](#). A guide shall be attached to the pump cylinder.

6.4.2 Piston

The thickness and height of piston(s) shall be minimum of 3.5 mm and 16 mm respectively. In case the piston is made out of synthetic rubber it shall withstand the test specified in [12.3](#).

6.4.3 Piston Spreader

It shall be capable of holding the piston in its position and shape without distortion against, the wall of the pump cylinder.

6.4.4 Piston Rod

It shall not be less than 12.0 mm in diameter. A buffer shall be provided on the piston rod, so as to prevent direct impact of the piston against the guide.

The piston rod shall withstand the test prescribed in [12.1](#).

6.4.5 Guide

A guide shall be attached to the pump cylinder.

6.5 Pressure Chamber

The pressure chamber shall have a minimum effective volumetric capacity of 16 times of the piston displacement.

The pressure chamber shall withstand the test prescribe in [12.2](#).

6.6 Threaded Connection

All metallic threaded connections on the sprayer and its components shall conform to IS 2643. The size designation and type of threads are as given in [Table 2](#). The engaged length of the threads shall not be less than 6 mm.

NOTE — The measurement of thread size shall be done by gauges and not by measuring absolute dimensions (see IS 10216).

6.7 Suction and Delivery Spout

There shall be one suction spout having serrated nipple or threaded connection and two delivery spouts with threaded connections. In case of nipple connection, the length of nipple shall be minimum 20 mm.

6.8 Suction Line

Suction line shall conform to the requirements as given below.

6.8.1 Suction Hose

A suction hose of suitable diameter and at least 2 m in length shall be provided agreed to between the purchaser and the supplier. The hose shall be connected with suction spout and strainer body through hose connections (see [6.8.3](#)).

Table 2 Threaded Connections

([Clause 6.6](#))

SI No.	Component	Type	Size Designation
(1)	(2)	(3)	(4)
i)	Suction spout	External	G1/2B
ii)	Delivery spout	External	G1/4B
iii)	Hose connection		
	a) For delivery spout	Internal	G1/4
	b) For cut off device	Internal	G1/4
iv)	Cut off device		
	a) Inlet end	External	G1/4B
	b) Outlet end	Internal	G 1/2 or G1/4
v)	Spray lance		
	a) Nozzle end	External	G1/4B
	b) Cut off device end	External	G 1/2B or G1/4B
	c) Bent portion for connection with straight and portion (in case of type B2)	Internal	G1/4
vi)	Spray gun inlet	External	G1/4B
vii)	Nozzle body	Internal	G1/4

6.8.2 Strainer Assembly

A removable strainer fitted in the strainer body shall be provided.

6.8.2.1 Strainer

The average size of any side or diameter of apertures of the strainer shall not be more than 625 µm.

NOTE — For measuring the size of apertures, select 10 consecutive apertures in the strainer and measure each side or diameter as the case may be. Report average the measured value.

6.8.2.2 Strainer body

The strainer body shall have a serrated nipple connection for attaching the suction hose. The length of the nipple shall not be less than 20 mm.

6.8.3 Hose Connections

6.8.3.1 For suction spout

The hose connection for threaded type and nipple type suction spout shall be nut-nipple and clamp type, respectively. The clamp shall be in the form of ferrule or clip.

6.8.3.2 For strainer body

The hose connection shall be clamp type. The clamp shall be in the form of ferrule or clip.

6.9 Discharge Line

6.9.1 Delivery Hose

One or two delivery hoses of suitable diameter and preferably 5 m in length shall be provided, as agreed to between the purchaser and the supplier. The hose shall be connected with delivery spout and cut-off device through hose connections (see [6.9.2](#)).

6.9.2 Hose Connections

6.9.2.1 For delivery spout

The hose connection shall be nut-nipple and clamp type. The clamp shall be in the form of ferrule or clip.

6.9.2.2 For cut-off device

The hose connection, for cut-off device aide having threaded or nipple connection, shall be nut-nipple and clamp type respectively. The clamp shall be in the form of ferrule or clip.

6.9.2.3 The delivery hose and hose connections shall withstand the test prescribed in [12.4](#).

6.9.3 Cut-off Device and Spray Lance/Spray Gun

Each sprayer shall be provided with a cut-off device and spray lance conforming to the requirements given in [Annex D](#) and [Annex E](#) or spray gun conforming to the requirements given in [Annex F](#).

NOTE — In case the cut-off device, spray lance and spray gun of types other than those specified in [Annex D](#), [Annex E](#) and [Annex F](#) are required by purchaser, for special purpose, its requirement shall be as agreed to between the purchaser and the supplier.

6.9.4 Nozzle

Unless otherwise specified by the purchaser, the nozzle shall conform to the requirements as given in [Annex G](#).

6.10 Gasket

Gasket of synthetic rubber wherever, provided, shall with stand the test prescribed in [12.3](#).

6.11 Total Mass

The total mass of the sprayer (see [3.5](#)) shall not be more than 11.5 kg.

7 OTHER REQUIREMENTS

7.1 Manual

The manual shall include technical specification of the sprayer, material of construction of various components shown in the exploded view of the sprayer, instructions for operations, calibration and maintenance, common faults and their remedies and safety precaution. Calibration procedure as per IS 11429 should be given in the manual

7.2 Spare Parts

Spare parts, separately packed for each sprayer according to the number required by the purchaser shall be provided. If no demand for spare parts has been made a set of gaskets, nozzles and safety gadgets shall be provided with each sprayer.

7.3 Safety

Each sprayer shall be provided with a set of masks, hand gloves and safety goggles.

8 WORKMANSHIP AND FINISH

8.1 The components of the sprayer shall have a smooth surface finish and shall be free from burrs, sharp edges and other defects that may be detrimental for their use.

8.2 The exposed steel parts shall have a protective coating to prevent surface deterioration. The steel used for hose ferrule/clip shall be plated with cadmium, zinc or nickel-chrome. Exposed brass parts may be given a suitable protective finish with clear transparent lacquer.

9 MARKING AND PACKING

9.1 Marking

Each sprayer shall be marked with the following particular:

- a) Manufacturer's name or recognized trade-mark; and
- b) Batch or serial number and month and year of manufacture.

9.2 BIS Certification Marking

The product(s) conforming to the requirements of this standard may be certified as per the conformity assessment schemes under the provisions of the *Bureau of Indian Standards Act, 2016* and the Rules and Regulations framed thereunder, and the products may be marked with the Standard Mark.

9.3 Packing

Each sprayer shall be packed, as agreed to between the purchaser and the supplier, for safe handling in transit.

10 SAMPLING FOR LOT ACCEPTANCE

Unless otherwise agreed to between the purchaser and the supplier, sampling of the sprayers for lot acceptance shall be done in accordance with **3** of IS 7201 (Part 1).

11 PERFORMANCE TESTS

11.1 Discharge Rate

11.1.1 The sprayer shall rigidly mounted on the test bench ([Fig. 3](#)). One end of the suction hose shall be connected to the suction spout of the sprayer and the other end with the strainer shall be submerged into a container filled with clean water.

11.1.2 The handle lever or extension in case of rocker sprayer shall be connected to an adjustable

crank mechanism operated by a motor through a speed-step down drive so as to give movement of 16 ± 1 cycles per minute to the piston rod in such a manner as to maintain the proper alignment between the piston rod and pump cylinder.

11.1.3 One end of a hose of 2 m length shall be connected to one of the delivery spouts of the sprayer and the other end to the inlet end of a straight rigid tube of 75 cm length and of 6 mm internal diameter. The other delivery spout shall be plugged.

11.1.4 A pressure regulator shall be fitted at the outlet end of the rigid tube to adjust the pressure.

11.1.5 An extension tube of suitable shape may be filled at the outlet end of the pressure regulator for collecting the discharge of water in a container.

11.1.6 A pressure gauge (*see* IS 3624) having full scale reading from 0 to not exceeding 2.5 times and not less than 1.5 times the normal working pressure of the sprayer, shall be fitted in the rigid tube at a distance of 15 cm from the inlet end of the pressure regulator on its upstream side.

11.1.7 The rigid tube with the pressure gauge and the pressure regulator shall be mounted on a separate test bench, other than the one with the driving unit in order to eliminate vibration.

11.1.8 The crank mechanism shall be adjusted so as to utilize the full stroke of the sprayer.

11.1.9 The piston rod shall be operated at a constant speed of 16 ± 1 cycles per minute.

11.1.10 The pressure regulator shall be adjusted to develop a pressure of 600 kPa within a fluctuation of ± 20 percent. Additional pressure chamber may be mounted to reduce the pressure fluctuation during test.

11.1.11 The discharge of water in 1 min shall be collected and measured.

11.1.12 The above test shall be repeated four times and the average value of the measured discharge shall be calculated.

11.2 Test for Volumetric Efficiency

11.2.1 The discharge of water in 1 min or 10 successive strokes shall be collected and measured in accordance with [11.1](#) for the sprayer. Repeat the test four times and calculate average value of the measured discharge. Calculate the volume of water in one cycle, that is, in one discharge stroke from the average measured discharge.

11.2.2 Calculate the piston displacement by measuring the inner diameter of the pump cylinder and the actual length or one stroke. The inner diameter of the pump cylinder shall be measured below the bell mouth of the cylinder.

The length of one stroke shall be measured by subjecting the pump to a pressure of 300 kPa within a fluctuation of ± 20 percent.

11.2.3 Divide the value obtained in [11.2.1](#) by the value obtained in [11.2.2](#) and express the result in percentage.

11.2.4 The volumetric efficiency shall be recorded in the test report.

11.3 Test for Endurance

11.3.1 The sprayer or pump shall be operated in accordance with the method given for discharge rate test ([11.1](#)) for a minimum period of 48 h without measuring the liquid. The period should be covered minimum with continuous stretch of 6 h.

11.3.2 The sprayer or pump shall not show any leakage, deformation or breakdown during the test.

12 TESTS FOR COMPONENTS

12.1 Test for Frame, Piston Rod, Pedal Lever or Handle Lever and Extension

The frame, piston rod, handle lever and extension shall not break, deform or crack when the force is exerted on them at test pressure.

12.2 Test for Leakage and Deformation of Pressure Chamber, Pump Cylinder, Pressure Tank

12.2.1 Pneumatic Test

A hose shall be attached to the opening of the pressure chamber or pump cylinder or tank. In case there are a number of openings, other than the one to which the hose is attached shall be scaled. The pressure chamber or pump cylinder or tank shall then be pneumatically pressurized to a minimum of one and a half times the normal working pressure of the sprayer and the pressure shall be retained for a period of 1 min. The component shall be disconnected, immersed in water and examined for any leakage and deformation.

The pressure chamber or pump cylinder or tank shall not show any leakage or deformation during the test.

12.2.2 Hydraulic Test

With the similar connection as that of [12.2.1](#), the pressure chamber or pump cylinder or tank shall be pressurized to a static hydraulic pressure of a minimum of two and a half times the normal working pressure of the sprayer and the pressure shall be retained for a period of 1 min. The pressure chamber or pump cylinder or tank shall be examined for any leakage or deformation.

The pressure chamber or pump cylinder or tank shall not show any leakage or deformation during the test.

12.3 Test for Gasket and Piston Made up of Synthetic Material

12.3.1 All the gaskets/piston made up of synthetic material in the sprayer shall be immersed in test mixture of 60 percent kerosene, 5 percent benzene, 20 percent toluene and 15 percent xylene for a period of 72 h at a temperature of 27 °C to 33 °C and then dried in air at the same temperature range for 24 h. The gaskets then be placed in their original positions.

12.3.2 The sprayer complete with its discharge line shall be operated at its normal working conditions for 1 h.

12.3.3 The gaskets/piston fitted to the points shall not show any leakage during the test.

NOTE — This test shall be conducted at the end of all the tests with new set of gaskets/pistons.

12.4 Test for Hose and Hose Connection

12.4.1 The inlet of the hose shall be connected to a hydraulic pump through hose connection. The other end of the hose shall be connected to the appropriate cut-off device. The outlet of the cut-off device shall be closed, that is, no discharge is allowed. A minimum hydrostatic pressure of 1.5 MPa, using water as a liquid, shall be developed in the hose assembly and the pressure shall be retained for a period of 1 min.

12.4.2 The hose and hose connection shall not show any leakage, crack or breakage during the test.

NOTES

1 Test for hose and hose connection, cut-off device and lance may be conducted at a time.

2 The gaskets and piston test shall be conducted with a new set of gaskets and piston provided with sprayer.

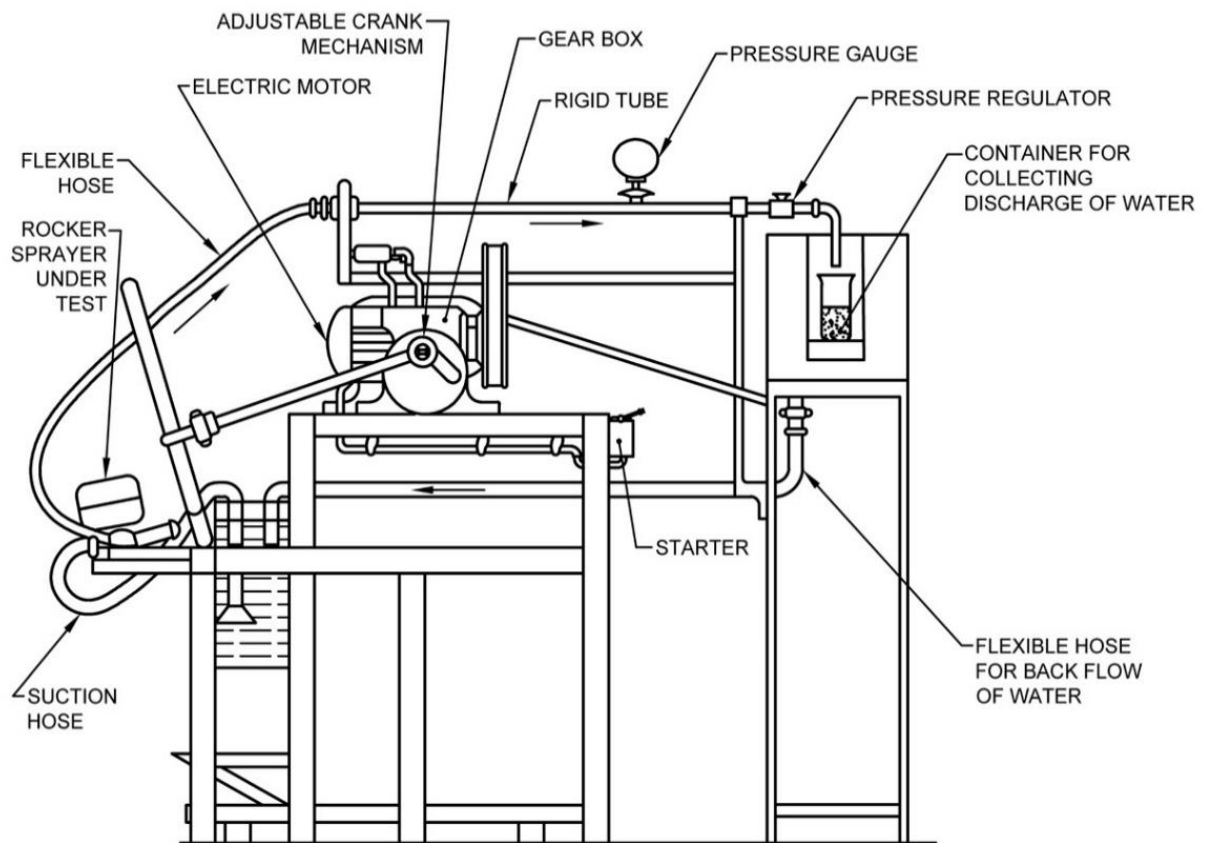

FIG. 3 RIG FOR CONDUCTING PUMP PERFORMANCE TEST ON ROCKER SPRAYER (SCHEMATIC)

ANNEX A

(Clause 2)

LIST OF REFERRED STANDARDS

<i>IS No.</i>	<i>Title</i>	<i>IS No.</i>	<i>Title</i>
IS 292 : 1983	Specification for leaded brass ingots and casting (<i>second revision</i>)		Hand-tools and hand-operated/animal-drawn equipment (<i>first revision</i>)
IS 2643 : 2005/ ISO 228-1 : 2000	Pipe threads where pressure-tight joints are not made on the threads — Dimensions, tolerances and designation (<i>third revision</i>)	IS 8480 : 2023/ ISO 5681 : 2020	Equipment for crop protection — Vocabulary (<i>second revision</i>)
IS 3624 : 1987	Specification for pressure and vacuum gauges (<i>second revision</i>)	IS 10216 : 1988/ ISO 228-2 : 1987	Pipe threads where pressure-tight joints are not made on the threads — Verification by means of limit gauges (<i>first revision</i>)
IS 7201 (Part 1) : 1987	Method of sampling for agricultural machinery and equipment: Part 1	IS 11429 : 1985	Method for calibration of sprayers

To access Indian Standards click on the link below:

https://www.services.bis.gov.in/php/BIS_2.0/bisconnect/knowyourstandards/Indian_standards/isdetails/

ANNEX B

(Foreword)

SPECIFICATION SHEET

- a) Name of the purchaser
- b) Preference of material for various components (*see* [4](#))
- c) Length of suction hose (*see* [6.8.1](#))
- d) Length of delivery hose (*see* [6.9.1](#))
- e) Type of cut-off device (*see* [6.9.3](#))
- f) Type of lance (*see* [6.9.3](#))
- g) Type of nozzle (*see* [6.9.4](#))
- h) Type of spray gun (*see* [6.9.3](#))
- j) Spray parts needed (*see* [7.2](#))
- k) Safety gadgets (*see* [7.3](#))

ANNEX C

(Clause 4.1)

LIST OF RELEVANT INDIAN STANDARDS FOR MATERIALS OF CONSTRUCTION

<i>IS No.</i>	<i>Title</i>	<i>IS No.</i>	<i>Title</i>
IS 28 : 1985	Specification for phosphor bronze ingots and castings (<i>fourth revision</i>)	IS 2062 : 2011	Hot rolled medium and high tensile structural steel — Specification (<i>seventh revision</i>)
IS 210 : 2009	Grey iron castings — Specification (<i>fifth revision</i>)	IS 2954 : 1978	Specification for vegetable tanned leather for belting (<i>first revision</i>)
IS 277 : 2018	Galvanized steel strips and sheets (plain and corrugated) — Specification (<i>seventh revision</i>)	IS 4170 : 1967	Specification for brass rods for general engineering purposes
IS 292 : 1983	Specification for leaded brass ingots and castings (<i>second revision</i>)	IS 4413 : 1981	Specification for brass wires for general engineering purposes (<i>first revision</i>)
IS 407 : 1981	Specification for brass tubes for general purposes (<i>third revision</i>)	IS 4454 (Part 1) : 2001	Steel wire for mechanical springs — Specification: Part 1 Cold drawn unalloyed steel wire (<i>third revision</i>)
IS 410 : 1977	Specification for cold rolled brass sheet, strip and foil (<i>third revision</i>)	IS 4687 : 1995	Gaskets and packings — Gland packings asbestos — Specification (<i>second revision</i>)
IS 617 : 2024	Aluminium and aluminium alloys ingots for remelting and castings for general engineering purposes — Specification (<i>fourth revision</i>)	IS 6528 : 1995	Stainless steel wire — Specification (<i>first revision</i>)
IS 737 : 2008	Wrought aluminium and aluminium alloy sheet and strip for general engineering purposes — Specification (<i>fourth revision</i>)	IS 6603 : 2024	Stainless steel semi-finished products, bars, wire rods and bright bars — Specification (<i>second revision</i>)
IS 739 : 1992	Wrought aluminium and aluminium alloys — Wire for general engineering purposes (<i>third revision</i>)	IS 6911 : 2017	Stainless steel plate, sheet and strip — Specification (<i>second revision</i>)
IS 1570 (Part 5) : 1985	Schedules for wrought steels: Part 5 Stainless and heat-resisting steels (<i>second revision</i>)	IS 7328 : 2020	Specification for polyethylene material for moulding and extrusion (<i>third revision</i>)
IS 1741 : 2019	Latex foam rubber products — Specification (<i>first revision</i>)	IS 7608 : 1987	Specification for phosphor bronze wire for general engineering purposes (<i>first revision</i>)
		IS 14329 : 1995	Malleable iron castings — Specification

To access Indian Standards click on the link below:

https://www.services.bis.gov.in/php/BIS_2.0/bisconnect/knowyourstandards/Indian_standards/isdetails/

ANNEX D

(Foreword and clause 6.9.3)

HAND-OPERATED CUT-OFF DEVICE

D-1 TYPES

The cut off device shall be the following types (see Fig. 4 and Fig. 5):

- a) Trigger type (Type A); and
- b) Knob type (Type B).

D-2 DIMENSIONS

D-2.1 The cross-sectional area of passage in valve body for liquid shall not be less than 12.0 mm².

D-2.2 The diameter of the valve stem shall be minimum 5 mm.

D-2.3 The length of the operating trigger, in Type A cut-off device, from the pivot axis shall be minimum 100 mm².

D-3 STRAINER

D-3.1 The cut-off device may be provided with a strainer on its outlet side, the flow of the liquid through strainer shall be from outward to inward.

D-3.2 The strainer area shall not be less than 1 000 mm².

The average size of any sides or diameter of apertures of the strainer shall not be more than 450 µm.

NOTE — For measuring the size of apertures, select 10 consecutive apertures in the strainer and measure each side or diameter as the case may be. Average the measured value and report.

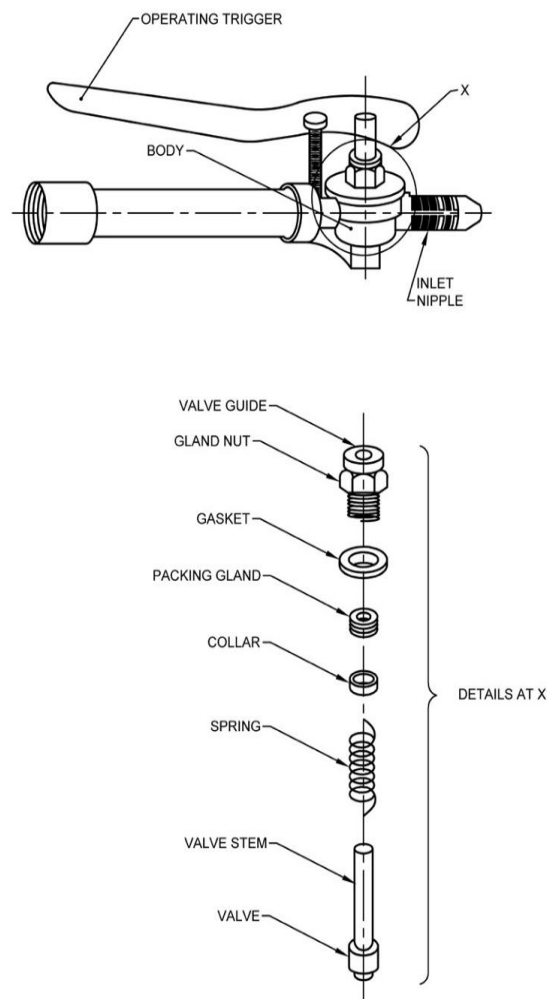

NOTE — Packing gland shown is optional, PVC gasket with or without PVC packing can be used instead.

FIG. 4 TRIGGER TYPE (TYPE A) CUT-OFF DEVICE

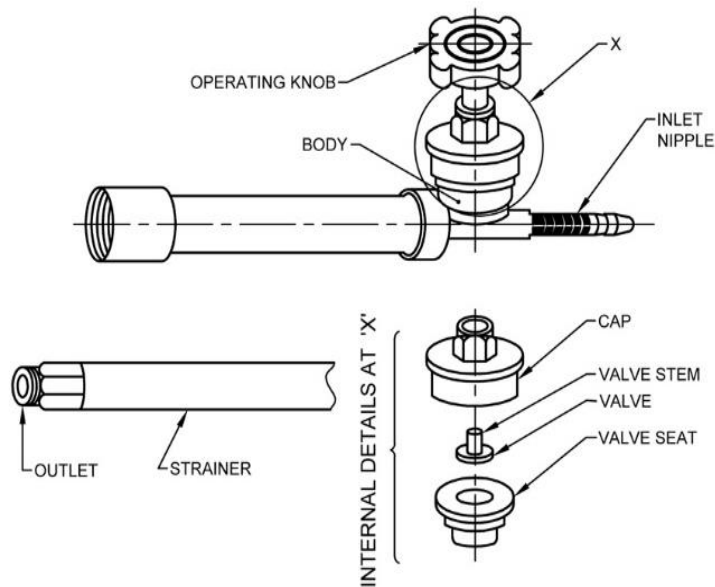

FIG. 5 KNOB TYPE CUT-OFF DEVICE

D-4 END-FITTINGS

D-4.1 The inlet end-fitting of the cut-off device for connecting the delivery hose, shall be nipple type or thread type. The length of the nipple shall not be less than 20 mm.

D-4.2 The outlet end-fitting of the cut-off device for connecting the lance shall be of thread type.

D-5 GASKETS

End fitting of thread type shall be provided with gaskets. If fitted to the external thread, it shall be recessed for at least one third of its thickness. Where fitted to internal thread, it shall at no time obstruct the passage of the liquid.

D-6 OPERATING TRIGGER/KNOB

D-6.1 The operating trigger in Type A cut-off device shall be attached with valve stem. A locking device shall be fitted which may be in the form of ring sliding over the trigger when the valve is in open position.

D-6.2 When tested in accordance with the method given in [D-6.2.1](#), the maximum torque required for trigger actuation shall not be more than 3.5 Nm (35 kgf.cm).

D-6.2.1 A suggestive arrangement for measuring the torque required to activate the cut-off device is

shown in [Fig. 6](#). The procedure for measurement is as given below:

- The cut-off device shall be mounted on a support rigidly;
- A U-bolt or other arrangement should be made for putting the weight at the rear most free end of the trigger;
- The distance (D) between the pivot point and the point of hanging or bolt or similar arrangement shall be measured;
- The weight of known mass shall be applied gradually till the point of application of trigger reaches from its highest position to the lowest possible position (carefully observe the actions while reaching the lowest possible position). Calculate the total weight W by adding the mass of the weights and the mass of the bolt or arrangement on which the weights were added;
- The torque shall be calculated by multiplying D and W; and
- The test shall be repeated and the average value in Nm (kgf.cm), shall be reported.

D-6.3 The operating knob in Type B cut-off device shall be suitably shaped for convenient handling.

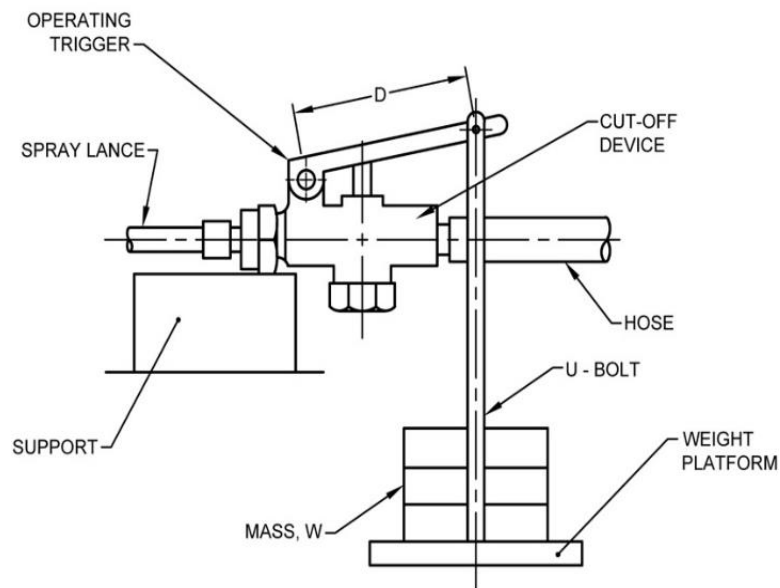

FIG. 6 ARRANGEMENT OF TRIGGER ACTUATION TEST

D-7 TESTS

The cut-off device shall withstand the strength, leakage and reliability tests as given in [D-7.1](#) and [D-7.2](#).

D-7.1 Strength Test of Cut Off Device

D-7.1.1 The inlet of the cut-off device shall be attached with a delivery hole and shall be coupled to a hydraulic pump.

D-7.1.2 The outlet of the cut-off device shall be closed, that is, no discharge shall be allowed from the device.

D-7.1.3 A hydraulic pressure of minimum 750 kPa shall be applied at the inlet of the device. The pressure shall be maintained for a period of 5 min.

D-7.1.4 During this test, the cut-off device should not crack or burst.

D-7.2 Leakage and Reliability Test

D-7.2.1 Test Apparatus

The test apparatus shall be vibration free and shall be so arranged that the valve of cut-off device can be activated at a speed of not more than 15 cycle per minute.

D-7.2.1.1 A typical test apparatus for trigger type cut-off device is given in [Fig. 7](#) and [Fig. 8](#). The dimensional and other details of cam follower and cam follower assembly except for cams given in [Fig. 8](#) are for guidance purpose only. The cam 1 in [Fig. 8](#) shall be used for operating the cut-off device and cam 2, if provided, may be used to operate a timing switch for counting the number of cycles.

D-7.2.1.2 A typical test apparatus for knob type cut-off device is given in [Fig. 9](#).

D-7.2.2 Test Liquid

The test liquid shall consist of a 5 percent suspension of any commercially available water dispersible powder.

The test liquid shall be changed after every 6 months of use.

D-7.2.3 Test Method

D-7.2.3.1 The cut-off device or spray gun shall be rigidly mounted on the appropriate test apparatus.

D-7.2.3.2 A spray nozzle or an orifice plate designed to deliver liquid approximately 0.75 litre per minute at a pressure of 300 kPa \pm 30 kPa shall be attached at the outlet of the device. The nozzle or orifice may discharge the liquid directly or through appropriate piping into reservoir from which the liquid is recycled.

D-7.2.3.3 The test liquid shall be applied to the inlet of the cut-off device or spray gun under a static pressure of $300 \text{ kPa} \pm 30 \text{ kPa}$ or $600 \text{ kPa} \pm 60 \text{ kPa}$ respectively. The cut-off device or spray gun shall be operated for 5 000 cycles at a speed of approximately 15 cycles per minute.

D-7.2.3.4 After operating for 5 000 cycles, the test shall be repeated for 500 cycles at a pressure of $600 \text{ kPa} \pm 60 \text{ kPa}$ for cut-off device and at $1\,200 \text{ kPa} \pm 120 \text{ kPa}$ for spray gun.

D-7.2.3.5 The cut-off device or spray gun shall not

drip or leak through the valve during the test.

D-8 MARKING

Each cut-off device shall be marked with the following particulars, if is procured by manufacturer from other source:

- a) Manufacturer's name or recognized trademark; and
- b) Batch or code number.

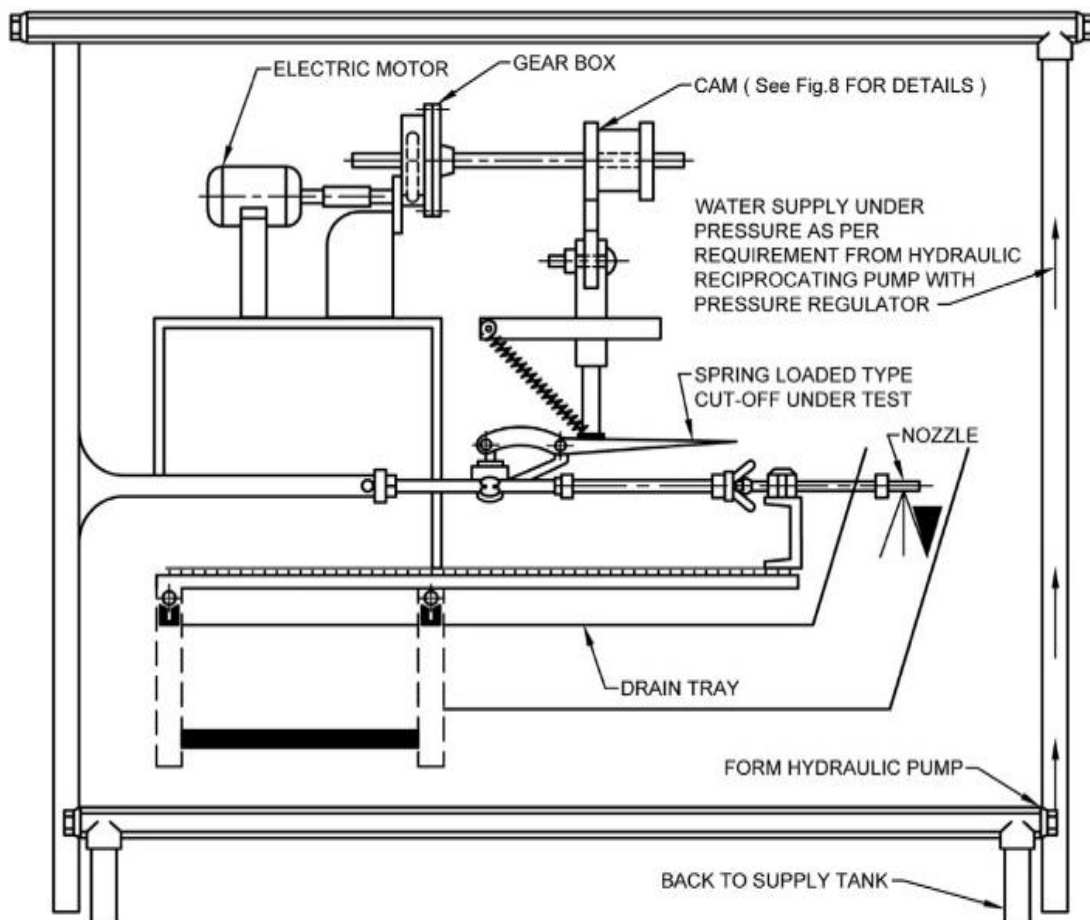

FIG. 7 TRIGGER TYPE CUT-OFF DEVICE DURABILITY TESTER (SCHEMATIC)

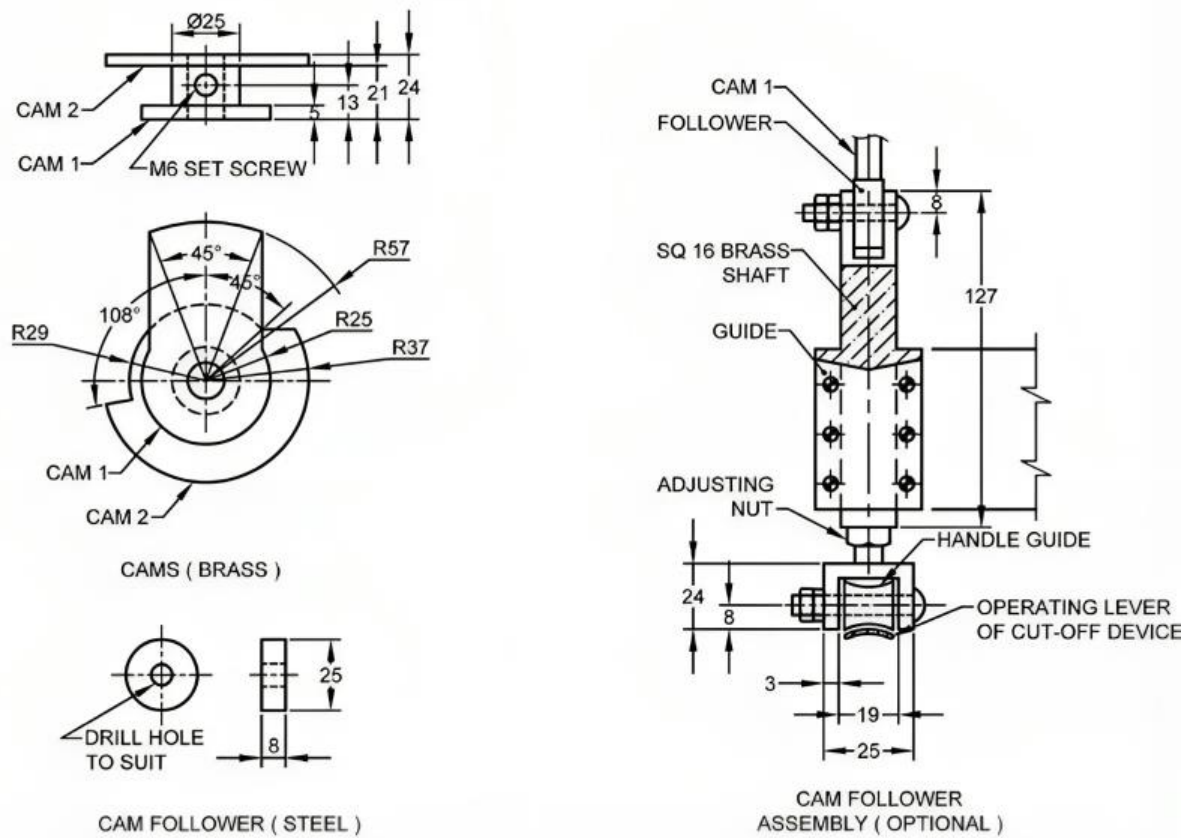

FIG. 8 DETAILS OF CAMS AND CAM FOLLOWER OF DURABILITY TESTER FOR TRIGGER TYPE CUT-OFF DEVICE

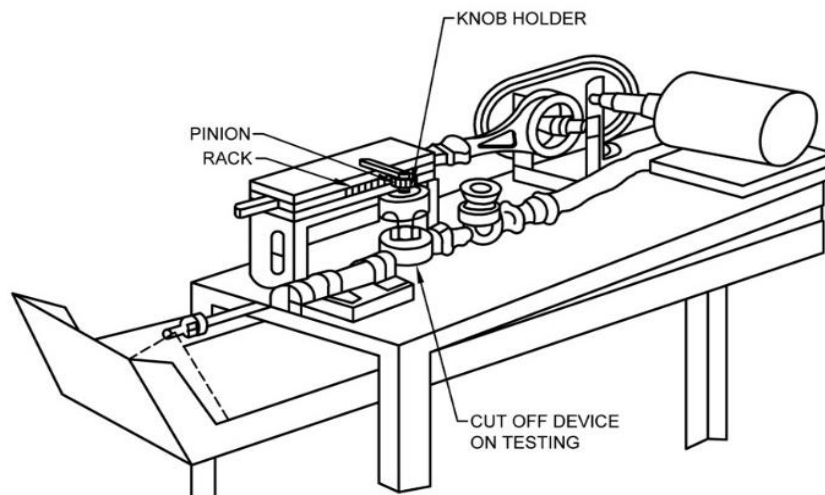

FIG. 9 KNOB TYPE CUT-OFF DEVICE DURABILITY TESTER (SCHEMATIC)

ANNEX E

(Foreword and clause 6.9.3)

SPRAY LANCE

E-1 TYPES

The lance shall be of following types (see Fig. 10):

- a) Straight type (Type A);
- b) Gooseneck type (Type B):
 - 1) Single piece (Type B₁); and
 - 2) Two piece (Type B₂).

E-2 MATERIALS

Brass or stainless steel or plastic tube shall be used. The material for end-fittings shall be the same as that of the tube.

E-3 DIMENSIONS

E-3.1 Minimum thickness of the wall of the tube

forming the lance shall be as given below:

- a) Brass tube — 0.60 mm; and
- b) Plastic tube — 3.0 mm.

E-3.2 Internal diameter of the tube shall not be less than 6 mm.

E-3.3 When measured vertically from sealing face to sealing face, as shown in Fig. 10 the nominal length of the lance shall be in between 500 mm and 900 mm \pm 2.5 percent

E-3.4 At least three-quarter length of Type B lance shall be straight and then provide a bent to the remaining length, a radius of not less than 35 mm at an angle of 45° to 60° (see Fig. 10).

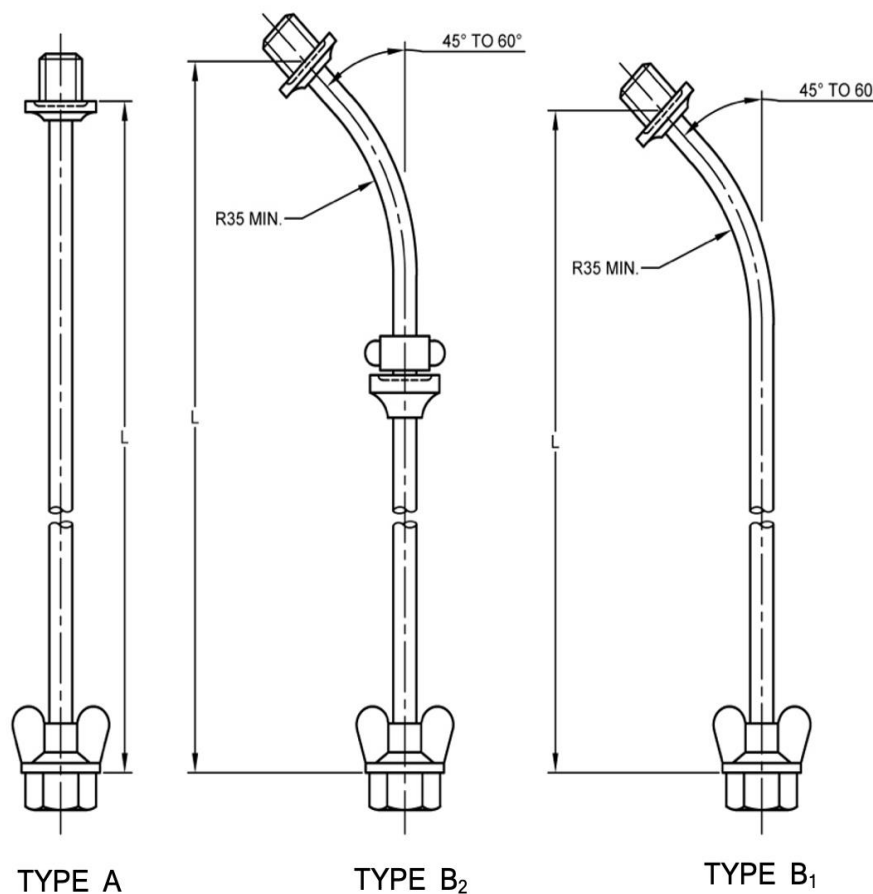

FIG. 10 LANCE

ANNEX F

(Foreword and clause 6.9.3)

HYDRAULIC SPRAY GUN

F-1 TYPES

The spray guns shall be of the following two types:

- a) Trigger type (*see* [Fig. 11](#)); and
- b) Screw type (*see* [Fig. 12](#)).

F-2 DIMENSIONS

F-2.1 The thickness of the wall of the barrel shall be minimum of 0.60 mm.

F-2.2 The diameter of the connecting rod shall be minimum of 5 mm.

F-2.3 The annular clearance between the barrel and the connecting rod shall not be less than 2.5 mm.

F-2.4 The total length of the spray gun when measured from the top of the nozzle to the tip of the trigger or screw shall be less than 500 mm.

F-3 PERFORMANCE AND STRENGTH REQUIREMENTS

F-3.1 The discharge rate of the spray gun for extreme adjustment for fine cone spray jet spray patterns at a pressure of 600 kPa ± 60 kPa shall be declared by the manufacturer.

The discharge rate when tested in accordance with [G-7](#), shall be within ± 10 percent of the declared value.

F-3.2 The spray angle of the spray gun at a pressure of 600 kPa ± 60 kPa for extreme adjustment of fine cone spray pattern shall be declared by the manufacturer. The angle, when tested in accordance with the method given in [G-9](#), by mounting the gun on test bench, shall not differ by ± 5° from the declared value.

F-3.3 When tested in accordance with the method given in [D-6.2](#) the maximum torque required in case of trigger type spray gun for triage actuation shall not be more than 7.0 Nm (70 kgf.cm).

F-3.4 The gun shall withstand the tests given in [F-3.4.1](#) and [F-3.4.2](#).

F-3.4.1 Test for Jet Spray

A circular area faced with blotting paper or any other

suitable paper shall be kept in a vertical place at a distance of 6 m from the tip of the gun. The place of the testing shall be free from drought. The gun shall be firmly secured horizontally at a height of about 1 m above the ground and it shall be operated at its working pressure (600 kPa ± 60 kPa). The jet spray from the spray gun shall reach the paper during the test.

F-3.4.2 Test for Strength

The spray gun shall be connected to a hydraulic pump. Nozzle tip shall be closed, that is no discharge shall be allowed through the nozzle. A hydraulic pressure of 1 500 kPa shall be applied to the gun up to a period of 5 min. During this test, the gun shall not leak, crack or bent.

F-3.5 When tested in accordance with the method given in [D-7.2](#) no leakage or breakdown shall occur in the spray gun.

F-3.6 Endurance Test

When tested in accordance with [G-7](#) and [G-9](#) at the pressure of 600 kPa ± 60 kPa after operating for 48 h duration with 6 h continuous stretch in each setting of the fine cone spray and jet spray pattern, the discharge rate and spray angle observed shall not vary by more than ± 10 percent and ± 5° respectively from the initial values obtained before the test.

F-4 OTHER REQUIREMENTS

F-4.1 The farthest point of the trigger in case of the trigger type distance shall not be exceeding 100 mm (to facilitate convenience grip by hand) when the valve is in closed position. When the trigger is pressed for full discharge it shall have a minimum clearance of 10 mm from to the barrel tube.

F-4.2 A lock shall be provided for locking the trigger in different positions to attain different spray patterns.

F-4.3 The total mass of the spray gun having length up to 1 000 mm shall not exceed 1.6 kg.

F-5 DESIGNATION

F-5.1 The gun shall be designated by its identification mark AG-C-J for fine cone spray and jet spray pattern, spray angle and discharge at a

nominal pressure of 600 kPa.

Example:

An adjustable spray gun capable of giving 80° spray angle with the discharge rate of 3 500 ml/min during jet spray at nominal pressure of 600 kPa shall be designated as AG-C80 1200-J 3500.

F-6 MARKING

Each gun shall be marked with the following particulars:

- a) Manufacturer's name or recognized trade mark; and
- b) Batch or code number.

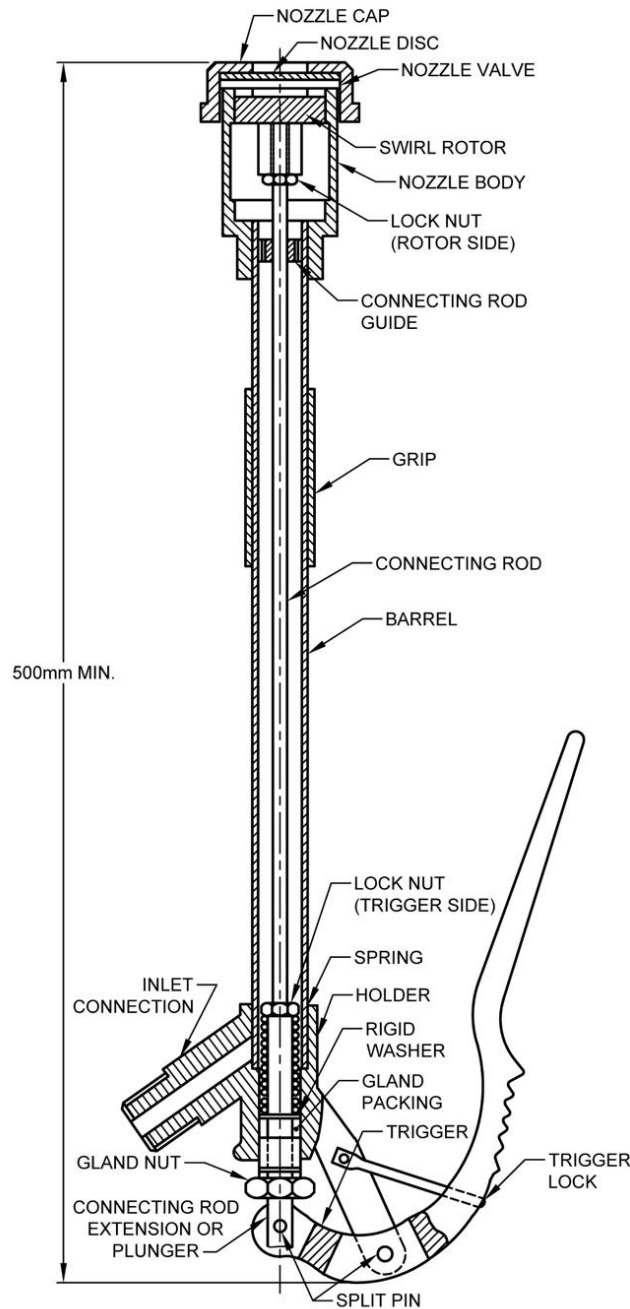

FIG.11 TRIGGER TYPE SPRAY GUN

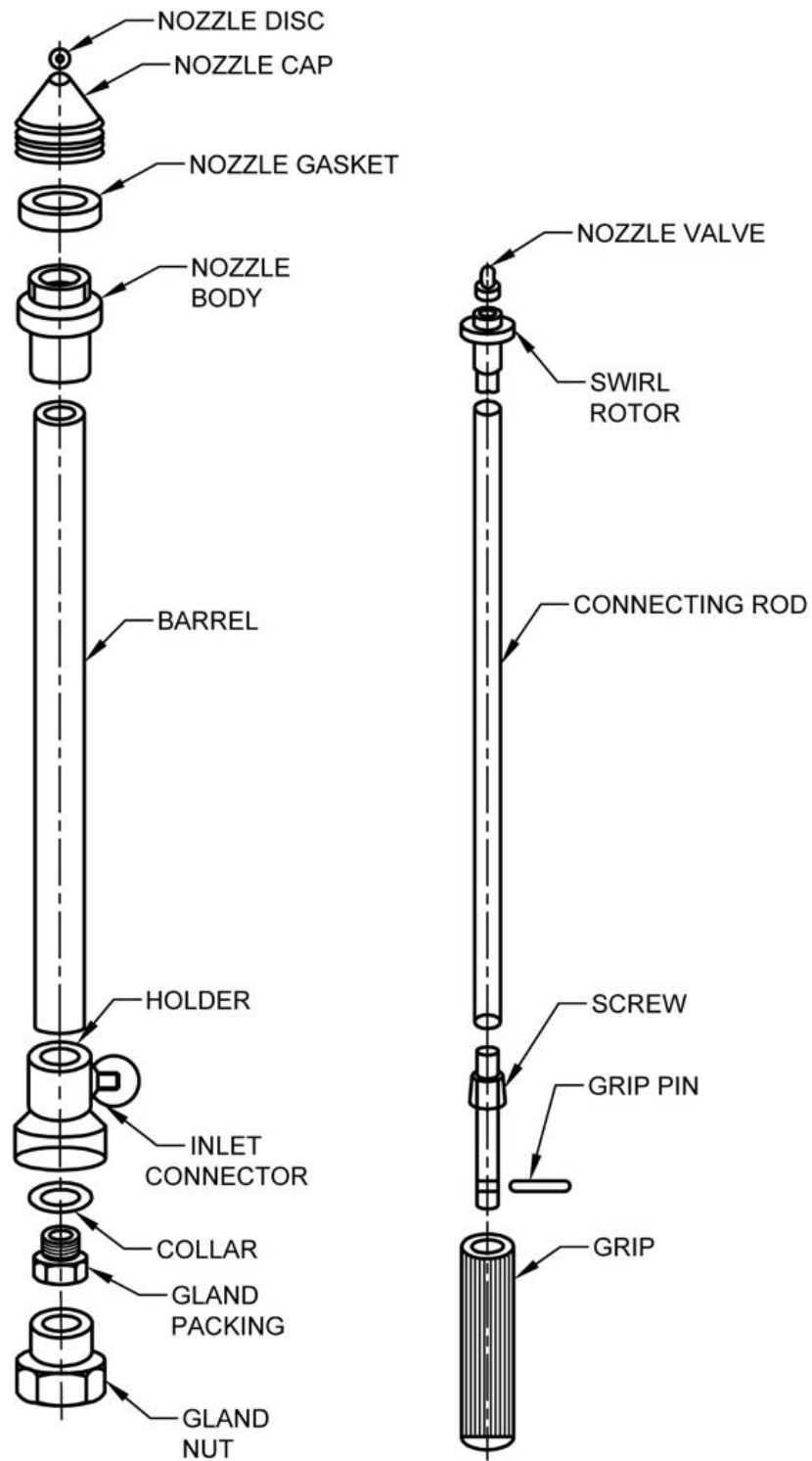

FIG.12 COMPONENTS OF SPRAY GUN (SCREW TYPE)

ANNEX G

(Foreword and clause 6.9.4)

HYDRAULIC SPRAY NOZZLE

G-1 TYPES

G-1.1 On the basis of spray distribution, the nozzles shall be of the following types:

- a) Hollow cone type (see Fig. 13);
- b) Fan type (see Fig. 14);
- c) Multi hole (see Fig. 15);
- d) Adjustable type:
 - 1) Double action type (see Fig. 16); and
 - 2) Triple action type (see Fig. 17).

G-1.2 On the basis of the method of attachment, the nozzles shall be of the following types:

- a) Fixed type; or
- b) Swivel type.

G-2 DESCRIPTION

G-2.1 The nozzle may consist of various components as shown in their respective figures.

G-2.1.1 A tangential velocity in the liquid emerging from cone nozzle orifice could be obtained either by passing it through a tangential or a helical slot in a swirl core or by sending it tangentially in the swirl chamber. Liquid is discharged from the orifice as a hollow cone of spray drops (see Fig. 18). Some nozzles of this type are adjustable producing any spray pattern from straight jet to wide angle hollow cone. The degree of atomization is governed by the relative sizes of swirl core and nozzle orifice.

G-2.1.2 Fan nozzles produce a spray pattern in the form of the flat sheet. Generally, the nozzle tip has a narrow hole that is especially shaped to curve inward towards its axis thus narrowing in immediately behind the orifice. The hole in nozzle is either rectangular or more commonly ventricular in shape. The size of the orifice governs the discharge rate at a given pressure.

G-2.1.3 In case of an adjustable nozzle the liquid if discharged from the nozzle orifice in the form of cone spray or jet spray of any pattern upon the axial adjustment of the spindle or body. The swirl core may be integral part of the tip or separately attached.

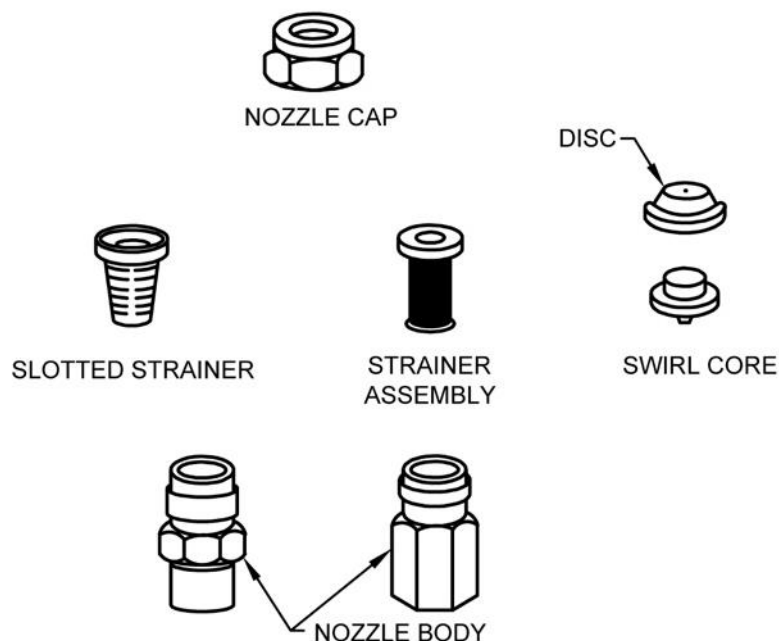

FIG. 13 CONE NOZZLE SHOWING PARTS

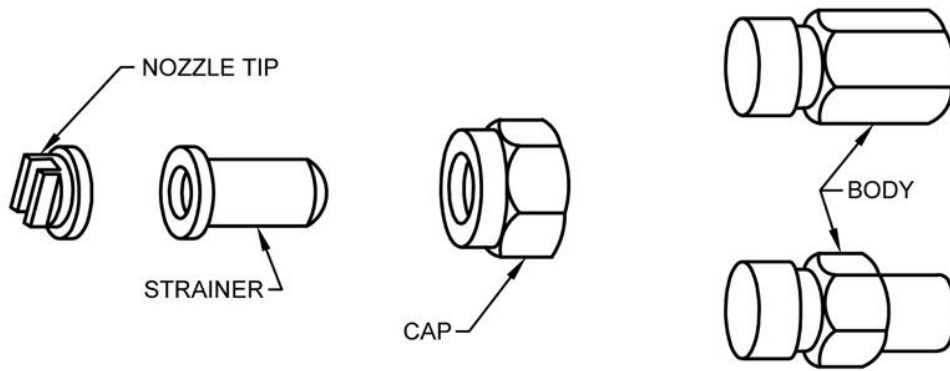

FIG. 14 FAN NOZZLE SHOWING PARTS

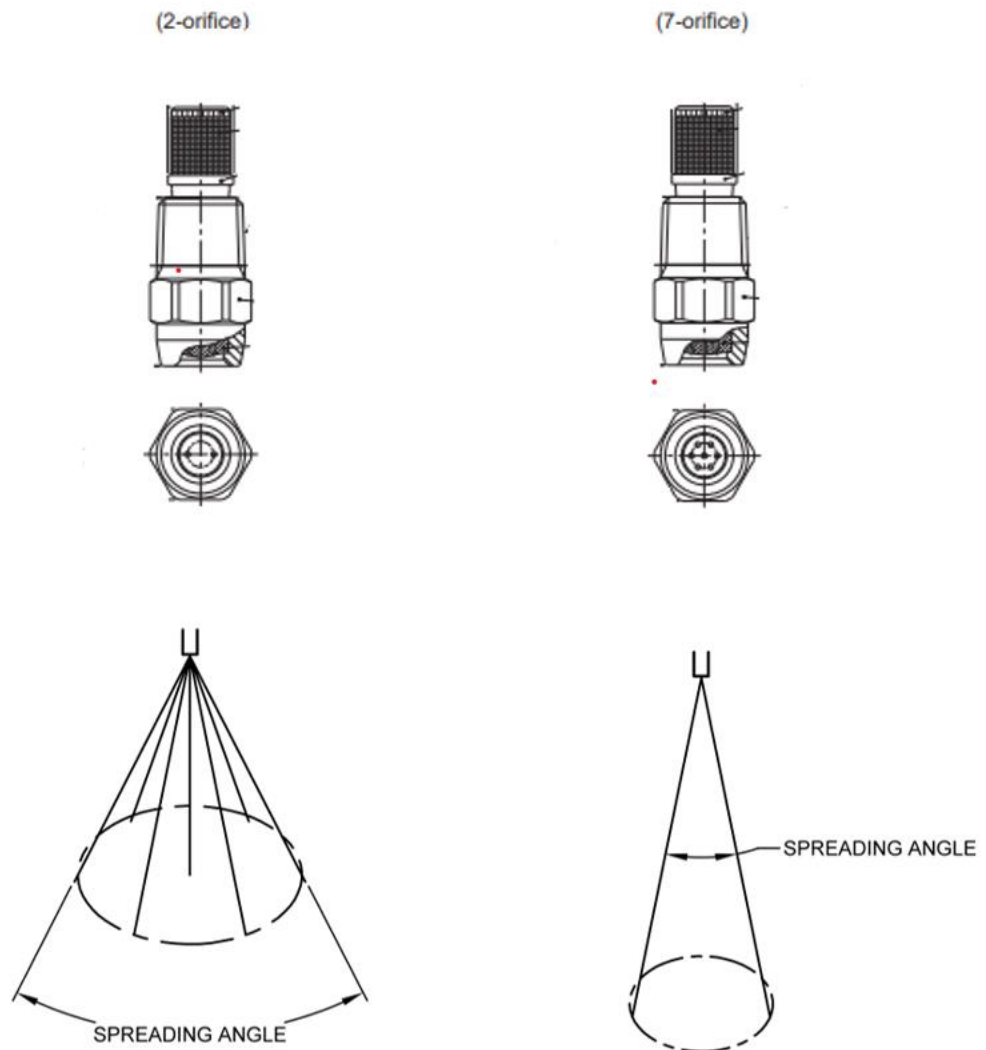

FIG. 15 MULTI HOLE NOZZLES

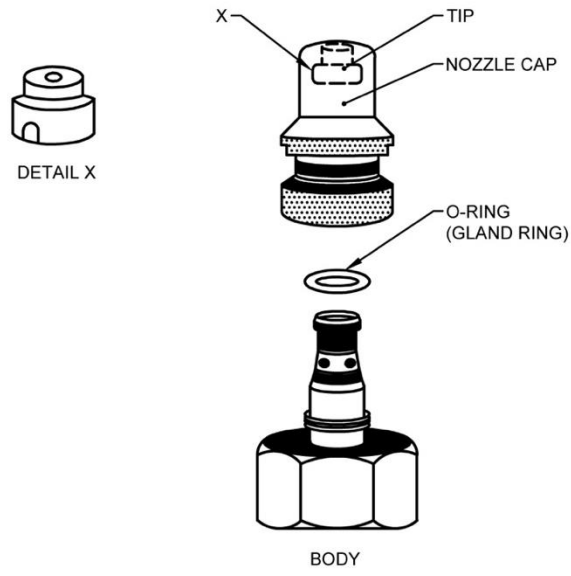

FIG. 16 DOUBLE ACTION NOZZLE

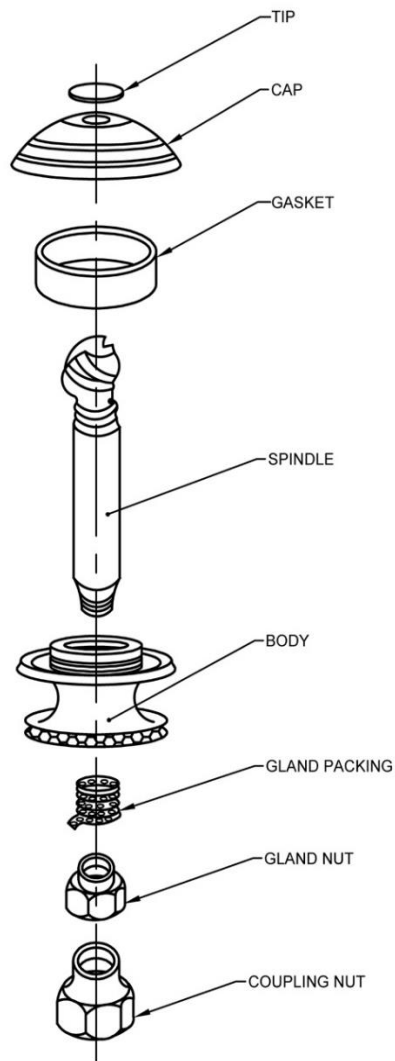

FIG. 17 TRIPLE ACTION NOZZLE

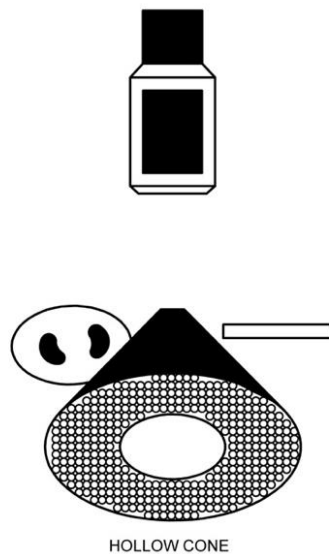

FIG. 18 CONE OR SWIRL NOZZLE

G-3 PERFORMANCE REQUIREMENTS

G-3.1 Rate of Discharge

G-3.1.1 The discharge rate of the nozzle shall be declared by manufacturer. In case of an adjustable nozzle, the declared value shall be for extreme adjustment for cone and jet spray pattern at a pressure of 300 kPa.

G-3.1.2 When tested in accordance with [G-7](#), the nozzle shall provide a rate of discharge as given in [Table 3](#). The rate of discharge shall be within ± 5 percent for fixed type and ± 10 percent for adjustable type nozzles of the declared value.

G-3.2 Spray Angle

The spray angle of the nozzle shall be declared by the manufacturer. The angle when tested in accordance with the method given in [G-9](#) shall not differ by $\pm 3^\circ$ for fixed type and $\pm 5^\circ$ for adjustable type nozzles from the declared value.

G-3.3 Endurance Test

The hydraulic spray nozzle when tested in accordance with [G-7](#) and [G-9](#) at a pressure of 300 kPa \pm 30 kPa after operating for 48 h duration with continuous stretches of 6 h, variation in discharge rate and spray angle from initial values should not be more than ± 10 percent and $\pm 3^\circ$ respectively.

G-4 OTHER REQUIREMENTS

G-4.1 If strainer is provided the average size of any side or diameter of the apertures shall not be more than 450 μm .

NOTE — For measuring the size of apertures, select 10 consecutive apertures in the strainer and measure each side or diameter as the case may be. Consider average of the measured value and report.

G-4.2 At the option of the purchaser, the provision shall be made for rotating of nozzle by hand to make it swivel type.

NOTE — With swivel arrangement, it is possible to adjust the nozzle to spray in any direction without changing the position of lance or boom (*see* [Fig. 19](#)).

G-5 DESIGNATION

The cone and fan nozzle shall be designated by its identification in mark A for agricultural use and B for public health use to (*see* [Note](#) in [Table 3](#)), spray angle and discharge rate. An adjustable nozzle shall be designated by identification mark AN-C-J for cone and jet spray pattern and discharge rate at a controlled pressure of 300 kPa.

Examples:

A nozzle for agricultural use giving 90° spray angle with discharge rate of 300 ml/min shall be designated as: A 90300.

A nozzle for public health use giving 80° spray angle with discharge rate of 900 ml/min shall be designated as: B 80900.

during extreme adjustment of cone spray and discharge rate of 1 800 ml/min during jet spray at a controlled pressure of 300 kPa shall be designated as: AN-C 60 600-J 1800.

An adjustable nozzle capable of giving 60° spray angle with discharge rate of 600 ml/min

Table 3 Rate of Discharge of Nozzles

(Clauses G-3.1.2 and G-5)

SI No.	Normal Discharge Rate in ml/min at Pressure of	
	(75 kPa)	(300 kPa)
(1)	(2)	(3)
i)	150	225
ii)	200	300
iii)	225	337
iv)	300	400
v)	337	450
vi)	400	600
vii)	450	675
viii)	600	800
ix)	675	900
x)	900	1 200
xi)	1 200	1 350
xii)	1 350	1 800
xiii)	1 800	2 400
xiv)	2 700	2 700
xv)	3 600	3 600
xvi)	4 500	4 500

NOTE — The nozzle for public health purpose and agricultural purpose would be tested at 75 kPa and 300 kPa respectively.

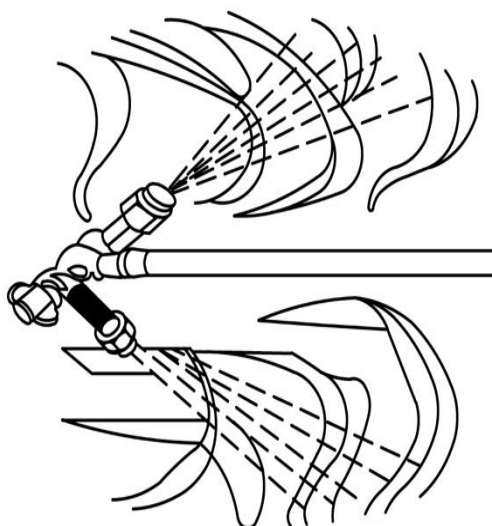

FIG. 19 NOZZLE WITH SWIVEL ARRANGEMENT SPRAYING UNDER LEAF

G-6 WORKMANSHIP AND FINISH

G-6.1 The components of the spray nozzle shall be free from burrs and other defects; this applies particularly to the internal surfaces and especially to the orifice.

G-6.2 The mating faces of the cap, tip and nozzle body or boss shall be finished flat so as to seal on the end face of the nozzle body or boss; a gasket may be used, if necessary.

G-6.3 The screw threads shall be well formed and the crests of the threads shall be free from burrs or any other defects which may prevent free engagement.

G-7 METHOD OF TEST FOR DISCHARGE RATE

G-7.1 The nozzle under test, shall be connected to a supply of clean water or spray materials which are equal in density surface tension and viscosity of water. The water or spray material shall be under a controlled pressure of 75 kPa or 300 kPa or 600 kPa (as the case may be) with the pressure gauge (IS 3624). The pressure gauge shall be positioned immediately before the nozzle and shall have full scale reading of pressure from 0 to not exceeding 2.5 times, not less than 1 time, that is to be read. The fluctuation of the pressure during the test shall not be more than 10 percent from the controlled pressure.

G-7.2 Turn of the supply and adjust the pressure and direct the spray for a period timed by stop watch, into receiving vessel so designed and as to collect to be whole of the spray from the nozzle. The period shall not be less than 60 s or not less than the time required to discharge 500 ml, whichever is higher.

G-7.3 Direct the spray away from the vessel and turn off the supply. Measure the volume of the water or the spray material and calculate the discharge rate per minute.

G-7.4 Repeat the above test for at least four times and obtain average rate of discharge per minute.

G-8 METHOD OF TEST FOR SPRAY DISTRIBUTION

G- 8.1 Apparatus

G-8.1.1 *Patternator*

The patternator (*see* [Fig. 20](#)) normally consist of 16 channels each 25 mm \pm 0.5 mm wide and of any convenient length provided that it encompasses the

area of the spray. The number of channels may be increased or decreased so that the whole of the spray falls within the patternator. The channels lead the liquid directly to the measuring tube having a bore not more than 24 mm and be a long enough to hold minimum of 200 ml test liquid. The depth of channels shall be at least 50 mm and shall have provision to avoid rebound of the spray droplets. The top edge of the trough dividers shall be round (tapered to 2.0 mm \pm 0.5 mm on the top edge) and straight in the horizontal plane, so that no point along with the edge lies more than 1 mm from the straight line joining the corresponding point at positioned so that when a straight edge is laid across the full width of the front and back of the troughs no edge lies more than 1 mm below this. Each divider shall be straight in the vertical plane to within \pm 0.5 mm.

NOTE — The surface of patternator should be such that the droplets should not stick on it.

G-8.1.2 A compressed air supply or small pump giving a steady output, with a liquid supply line from the reservoir of capacity two litres or more.

G-8.1.3 A constant pressure regulator and a pressure gauge should be installed as close to the nozzle as possible.

G-8.1.4 Establish a suitable means of holding the nozzle at the appropriate height with the required facilities for adjustments.

G-8.1.5 A test tube rack so made that the collecting tube can be inserted in the flow when constant flow has been achieved, and retracted after a predetermined period.

G-8.2 Method

G-8.2.1 Carry out the test directing spray, at standard rate of discharge and standard pressure, from the nozzle on the patternator protected by screens from draughts.

G-8.2.2 In the case of fan spray nozzles, mount the nozzle so that the axis of spray sheet is right angle to the upper surface of the trough divisions on the patternator and the nozzle tip at a height of 545 mm above the trough division. In case of cone nozzle, mount the nozzles so that axis of its spray cone is at right angles to the upper surface of the trough division on the patternator and the nozzle tip at a height of 545 mm above trough divisions.

G-8.2.3 Test the cone spray nozzle in three different positions of nozzles, namely, 90°, 180° and 270° (*see* [Fig. 21](#)).

G-8.2.4 The total amount of liquid sprayed for each individual test shall be about a litre.

G-8.2.5 As soon as the amount collected in any of measuring tube has reached 180 ml, collection is discontinued taking care that no water from the patternator fall into any of measuring tubes.

G-8.2.6 The volume of the water in each measuring tube shall be determined and a graph prepared by plotting the volume of water in each tube against its position in the patternator (see Fig. 22 and Fig. 23).

G-9 METHO OF TEST FOR SPRAY ANGLE

G-9.1 Carry out test at a place protected from draughts. Mount the nozzle on the test rig as shown

in Fig. 24. Connect the nozzle to supply of clean water. A pressure gauge having full scale reading of pressure not exceeding 2.5 times or not less than 1.5 times of the pressure to be read, shall be connected immediately before the nozzle.

G-9.2 Commence the spray at a controlled pressure of 75 kPa or 300 kPa or 600 kPa (as the case may be) within the fluctuation of ± 10 percent. Adjust the arms of the protector as shown in test rig (see Fig. 25) so as to coincide with the clearly visible straight boundary lines of the nozzle spray pattern as shown in Fig. 25. Read the spray angle directly on the protractor and round it off in whole degree.

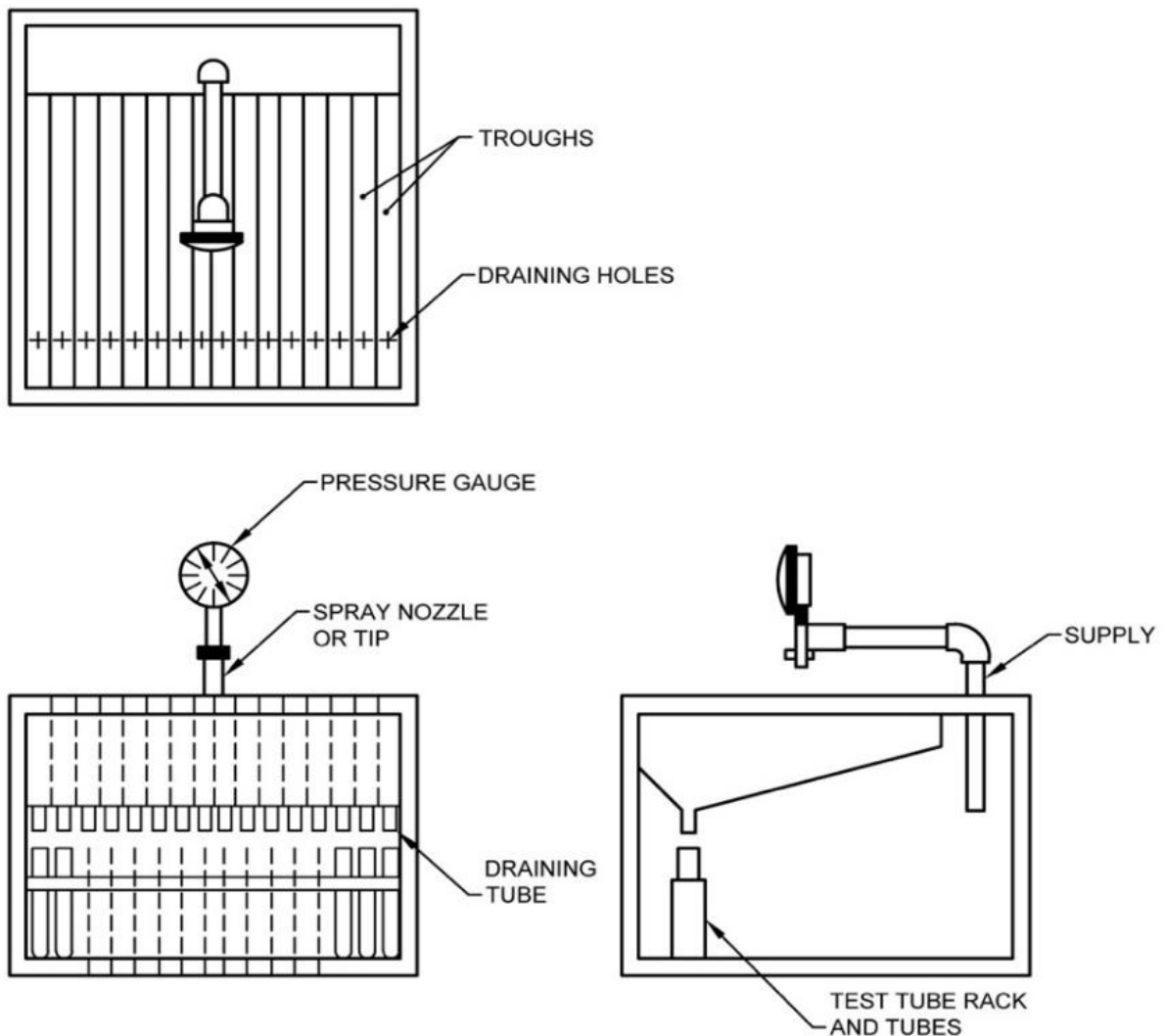

FIG. 20 PATTERNATOR FOR SPRAY DISTRIBUTION TEST

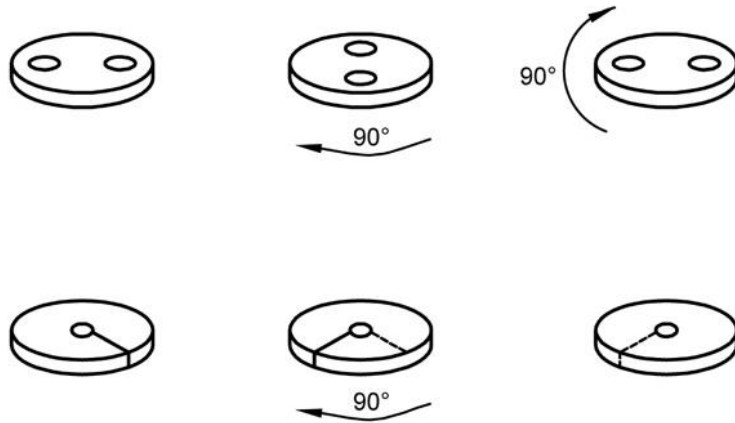

FIG. 21 TEST POSITION FOR CONE SPRAY NOZZLE

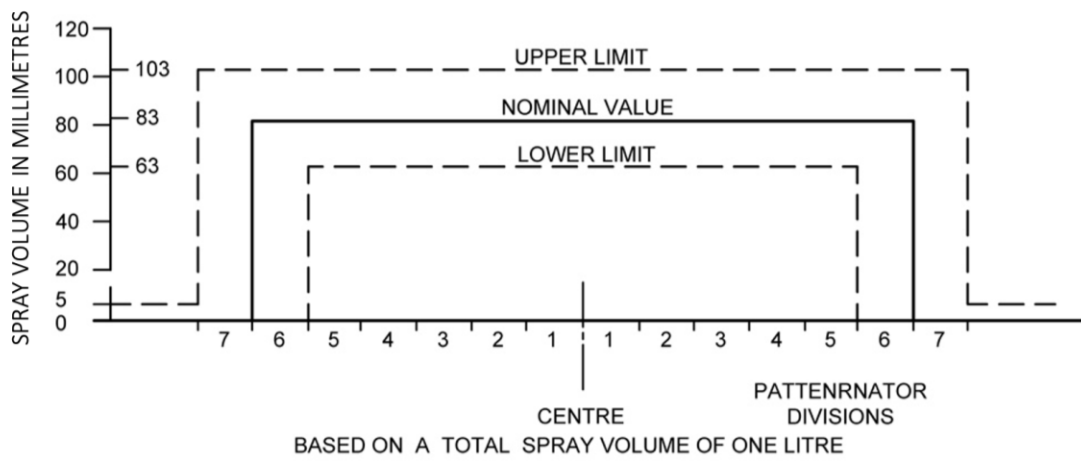
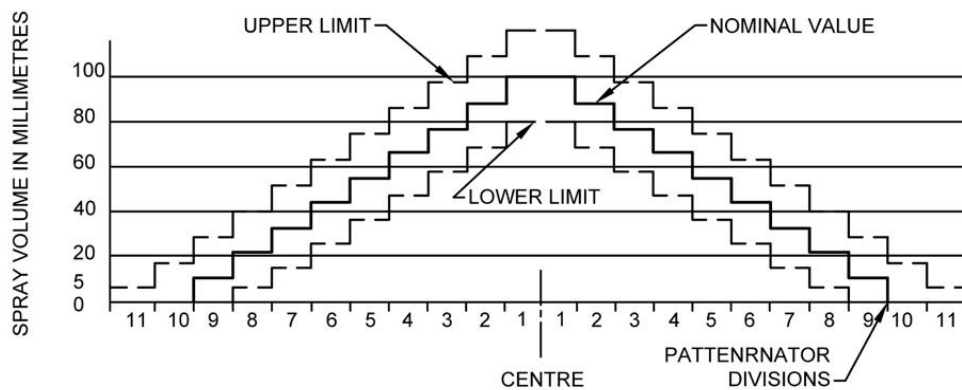

FIG. 22 RECTANGULAR DISTRIBUTION LIMITS



BASED ON A TOTAL SPRAY VOLUME OF ONE LITRE
 TOLERANCE ON EACH DIVISION IS ± 20 ml. DECREMENT OF NOMINAL VALUE
 OUTLINE IS 11.1 ml PER TUBE.

FIG. 23 TRIANGULAR DISTRIBUTION LIMIT

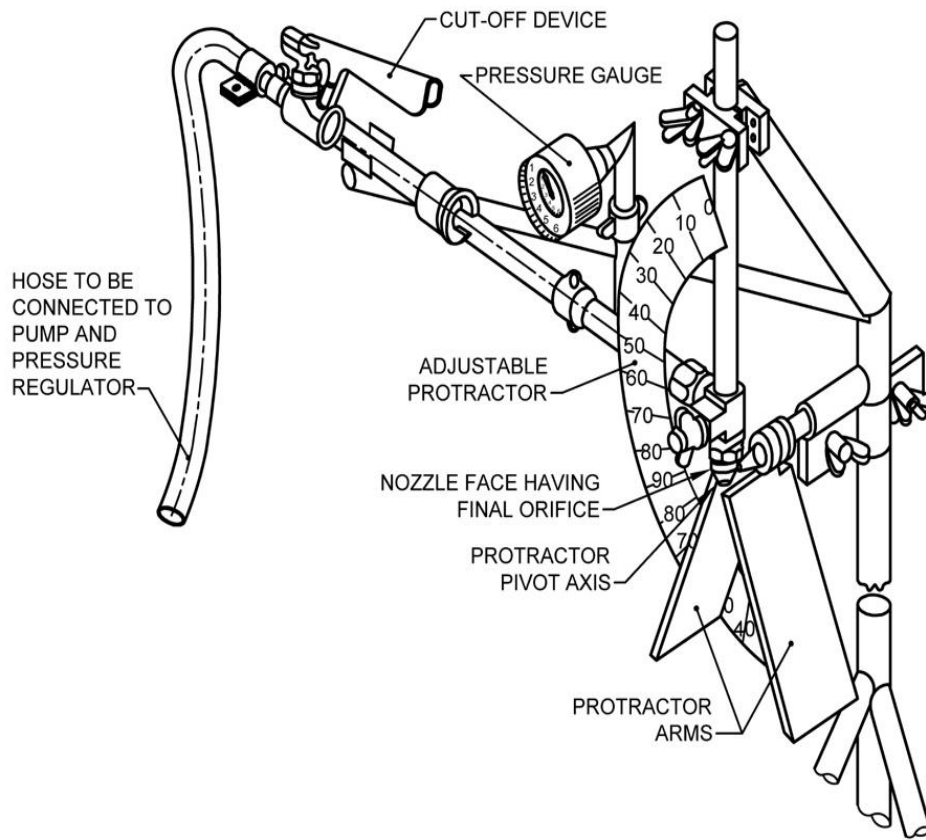

FIG. 24 TEST RIG FOR MEASUREMENT OF NOZZLE SPRAY ANGLE (SCHEMATIC)

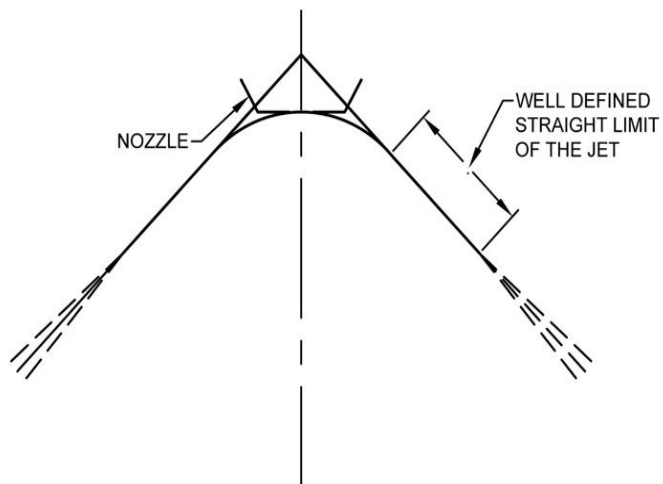

FIG. 25 DIAGRAM OF THE PRINCIPLE FOR MEASURING SPRAY ANGLE

G-10 METHOD OF TEST FOR VARIATION IN DISCHARGE AND DISTRIBUTION DUE TO ABRASION AND CORROSION

This test does not prejudge the life of a nozzle in the actual conditions of use, but is used to compare the resistance of wear of the nozzle and result of deterioration in the distribution.

G-10.1 Test Liquid

G-10.1.1 Clean water with the addition of 20 g/l of abrasive or corrosive material shall be used as a test liquid. The abrasive material may be a synthetic silica powder of following chemical and physical properties:

<i>Sl No.</i>	<i>Property</i>	<i>Requirement</i>
(1)	(2)	(3)
i)	Bulk density	160 kg/m ³
ii)	Specific gravity	1.95
iii)	Average particle size	0.002 2 μm
iv)	Colour	White
v)	Refractive index	135 to 165
vi)	Surface area	140 m ³ /g to 160 m ³ /g
vii)	pH (5 % water suspension)	7.3
viii)	Loss at 105 °C	5 percent
ix)	Loss at 1 200 °C	10 percent
x)	SO ₂ content	87 percent
xi)	CaO content	0.5 percent
xii)	Fe ₂ O ₃ content	0.2 percent
xiii)	Al ₂ O ₃ content	0.6 percent
xiv)	NaCl content	1.0 percent

G-10.1.2 Ensure that the abrasive material is always well dispersed throughout the liquid. This may be done by means of controlled escape of compressed air with such a pressure so that after 5 min of

operation, no deposit of abrasive material is left at bottom of tank.

G-10.1.3 Ensure, if need be by preliminary tests that the liquid retains its effectiveness in relation to the material of nozzle throughout the duration of the test defined in [G-10.2](#). If it does not, replace the abrasive liquid as often as necessary.

NOTE — It is possible to proceed using identical metering orifices from the same batch made from a suitable material in relation to nozzle being tested, measuring the increase in discharge rate after passing through a given volume of the test liquid at a specified pressure.

G-10.1.4 The temperature of the test liquid as all be 20 °C ± 3 °C throughout the test.

G-10.2 Method

G-10.2.1 Measure the discharge rate at the beginning of the test at a controlled pressure (the fluctuation shall not be more than ± 10 percent) and then every hour or at a regular interval chosen according to the speed of wear out of nozzle or at discharge of 4 litres intervals. It shall be continued until the nozzle is abraded to the point where the flow increases beyond the allowable limit of 6 percent.

G-10.2.2 Carry out the spray distribution test at the beginning and the end of the test for about 10 percent, 15 percent and 20 percent of increase in discharge rate if these values are reached.

G-10.3 Result

G-10.3.1 State in the test report the increase in discharge rate thus obtained shall be expressed as a percentage of the initial discharge rate and as function of test period.

G-10.3.2 Also give spray distribution observed at the various degree of wear indicated in [G-10.2.2](#).

G-11 MARKING

Each nozzle shall be marked with the following particulars, if procured from other agencies:

- a) Manufacturer's name or recognized trade-mark; and
- b) Nozzle designation (*see* [G-5](#)).

ANNEX H

(Foreword)

COMMITTEE COMPOSITION

Agriculture Machinery and Equipment Sectional Committee, FAD 11

<i>Organization</i>	<i>Representative(s)</i>
ICAR - Central Institute of Agricultural Engineering, Bhopal	DR C. R. MEHTA (<i>Chairperson</i>)
Agricultural Machinery Manufacturers Association (AMMA- India), Gandhinagar	DR SURENDRA SINGH SHRI MITUL PANCHAL (<i>Alternate</i>)
All India Farmers Alliance, New Delhi	DR RAJARAM TRIPATHI SHRIMATI APURVA TRIPATHI (<i>Alternate</i>)
Aspee Agro Equipment Pvt Ltd, Mumbai	SHRI JATIN S. PATEL SHRI GANGADHAR VARPE (<i>Alternate</i>)
Automotive Research Association of India, Pune	SHRI A. AKBAR BADUSHA SHRI GIRISH TANAWADE (<i>Alternate I</i>) SHRI GANGARAM AUTI (<i>Alternate II</i>)
CCS Haryana Agricultural University, Hisar	DR VIJAYA RANI
Central Farm Machinery Training and Testing Institute, Budni	SHRI ANIL KUMAR UPADHYAY SHRI BABUL NATH DIXIT (<i>Alternate I</i>) SHRI PARTH LODH (<i>Alternate II</i>)
CLAAS India Pvt Ltd, Chandigarh	SHRI KRISHNA PRABHAKAR SINGH
CNH Industrial India Pvt Ltd, Pune	SHRI SANTHOSH RAO SHRI SUJIT HINGE (<i>Alternate</i>)
Consumer Guidance Society of India, Mumbai	SHRI SITARAM DIXIT
Dasmesh Mechanical Works Pvt Ltd, Malerkotla	SHRI SARBJEET SINGH PANESAR SHRI GURDEEP SINGH PANESAR (<i>Alternate</i>)
ICAR - All India Coordinated Research Project on Ergonomics and Safety in Agriculture, Bhopal	DR SUKHBIR SINGH DR RAHUL R. POTDAR (<i>Alternate I</i>) SHRIMATI SWEETI KUMARI (<i>Alternate II</i>)
ICAR - All India Coordinated Research Project on Farm Implements and Machinery, Bhopal	DR K. N. AGRAWAL
ICAR - All India Coordinated Research Project on Utilization of Animal Energy, Bhopal	DR S. P. SINGH
ICAR - Central Institute of Agricultural Engineering, Bhopal	DR V. P. CHAUDHARY DR U. R. BADEGAONKAR (<i>Alternate I</i>) DR DILIP JAT (<i>Alternate II</i>)
Indian Council of Agricultural Research, New Delhi	DR PANNA LAL SINGH

<i>Organization</i>	<i>Representative(s)</i>
John Deere India Pvt Ltd, Pune	SHRI ANAND RAJ SHRI CHANDRASHEKHAR DESHMUKH (<i>Alternate I</i>) SHRI PRATIK DURAPHE (<i>Alternate II</i>)
Kerala Agro Machinery Corporation Ltd (KAMCO), Athani	SHRI A. UNNIKRISHNAN SHRI P. C. SAJIMON (<i>Alternate</i>)
Kubota Agricultural Machinery India Pvt Ltd, Faridabad	SHRI ASHOK KUMAR SHRI ASHISH KUMAR MALLARH (<i>Alternate</i>)
Maharana Pratap University of Agricultural and Technology, Udaipur	DR SANWAL SINGH MEENA
Mahatma Phule Krishi Vidyapeeth, Rahuri	DR SACHIN MADHUKAR NALAWADE SHRI VIKRAM PARASHARAM KAD (<i>Alternate I</i>) DR AVDHUT ASHOK WALUN (<i>Alternate II</i>)
Mahindra and Mahindra Ltd, Mumbai	SHRI PRADEEP SHINDE
Ministry of Agriculture, Department of Agriculture, New Delhi	DR V. N. KALE SHRI ARVIND N. MESHRAM (<i>Alternate</i>)
National Innovation Foundation, New Delhi	SHRI RAKESH MAHESHWARI SHRI MAHESH PATEL (<i>Alternate</i>)
National Institute of Plant Health Management, Hyderabad	DR VIDHU KAMPURATH P. SHRI MUTYALA UDAYA (<i>Alternate</i>)
North Eastern Region Farm Machinery Training and Testing Institute, Biswanath Charali	DR P. P. RAO SHRI S. G. PAWAR (<i>Alternate I</i>) SHRI KHAGENDRA BORA (<i>Alternate II</i>)
Northern Region Farm Machinery Training and Testing Institute, Hisar	DR MUKESH JAIN SHRI SANJAY KUMAR (<i>Alternate</i>)
Power Tillers Manufacturers Association, Kolkata	SHRI A. R. GANESH KUMAR
Punjab Agricultural University, Ludhiana	DR MAHESH KUMAR NARANG DR RAJESH GOYAL (<i>Alternate I</i>) SHRI APOORV PRAKASH (<i>Alternate II</i>)
Southern Region Farm Machinery Training and Testing Institute, Anantpur	DR B. M. NANDEDE
Tamil Nadu Agricultural University, Coimbatore	DR R. KAVITHA DR A. SURENDRA KUMAR (<i>Alternate I</i>) DR A. P. MOHANKUMAR (<i>Alternate II</i>)
Tirth Agro Technology Pvt Ltd 'Shaktiman', Rajkot	SHRI PARAG DEVIDAS BADGUJAR SHRI V. AUDI NARAYAN REDDY (<i>Alternate</i>)
Tractor and Mechanization Association, New Delhi	SHRI PHILIP KOSHY SHRI VEENIT NEGI (<i>Alternate I</i>) SHRIMATI DEVYANI (<i>Alternate II</i>)
Tube Investments Clean Mobility Pvt Ltd, Chennai	SHRI ABHISHEK SINHA SHRI S. O. TYAGI (<i>Alternate</i>)

<i>Organization</i>	<i>Representative(s)</i>
Voluntary Organisation in Interest of Consumer Education (VOICE), New Delhi	SHRI B. K. MUKHOPADHYAY
BIS Directorate General	SHRIMATI SUNEETI TOTEJA, SCIENTIST 'E'/DIRECTOR AND HEAD (FOOD AND AGRICULTURE) [REPRESENTING DIRECTOR GENERAL (<i>Ex-officio</i>)]

Member Secretary
SHRI VIKRANT CHAUHAN
SCIENTIST 'B'/ASSISTANT DIRECTOR
(FOOD AND AGRICULTURE), BIS

Sub-committee to Review of Indian Standards Related to Plant Protection Equipment, FAD 11 : 01

<i>Organization</i>	<i>Representative(s)</i>
ICAR – Central Institute of Agricultural Engineering, Bhopal	DR K. N. AGRAWAL (<i>Convener</i>)
Agriculture Machinery Manufacturers Association, Pune	DR SURENDRA SINGH
ASPEE Agro Equipment Private Limited, Mumbai	SHRI JATIN S. PATEL
Dr Balasaheb Sawant Konkan Krishi Vidyapeeth, Dapoli	DR PRASHANT U. SHAHARE
John Deere India Private Limited, Pune	SHRI CHANDRASHEKHAR DESHMUKH
Ministry of Agriculture, Department of Agriculture, New Delhi	SHRI ARVIND MESHARAM SHRI P. K. CHOPRA
National Institute of Plant Health Management, Hyderabad	DR VIDHU KAMPURATH P.
Northern Region Farm Machinery Training and Testing Institute, Hisar	DR MUKESH JAIN
Punjab Agricultural University, Ludhiana	DR MAHESH KUMAR NARANG
Southern Region Farm Machinery Training and Testing Institute, Anantapur	DR B. M. NANDEDE

Bureau of Indian Standards

BIS is a statutory institution established under the *Bureau of Indian Standards Act, 2016* to promote harmonious development of the activities of standardization, marking and quality certification of goods and attending to connected matters in the country.

Copyright

BIS has the copyright of all its publications. No part of these publications may be reproduced in any form without the prior permission in writing of BIS. This does not preclude the free use, in the course of implementing the standard, of necessary details, such as symbols and sizes, type or grade designations. Enquiries relating to copyright be addressed to the Head (Publication & Sales), BIS.

Review of Indian Standards

Amendments are issued to standards as the need arises on the basis of comments. Standards are also reviewed periodically; a standard along with amendments is reaffirmed when such review indicates that no changes are needed; if the review indicates that changes are needed, it is taken up for revision. Users of Indian Standards should ascertain that they are in possession of the latest amendments or edition by referring to the website-www.bis.gov.in or www.standardsbis.in.

This Indian Standard has been developed from Doc No.: FAD 11 (24450).

Amendments Issued Since Publication

Amend No.	Date of Issue	Text Affected

BUREAU OF INDIAN STANDARDS

Headquarters:

Manak Bhavan, 9 Bahadur Shah Zafar Marg, New Delhi 110002

Telephones: 2323 0131, 2323 3375, 2323 9402

Website: www.bis.gov.in

Regional Offices:

	Telephones
Central : 601/A, Konnectus Tower -1, 6 th Floor, DMRC Building, Bhavbhuti Marg, New Delhi 110002	{ 2323 7617
Eastern : 8 th Floor, Plot No 7/7 & 7/8, CP Block, Sector V, Salt Lake, Kolkata, West Bengal 700091	{ 2367 0012 2320 9474
Northern : Plot No. 4-A, Sector 27-B, Madhya Marg, Chandigarh 160019	{ 265 9930
Southern : C.I.T. Campus, IV Cross Road, Taramani, Chennai 600113	{ 2254 1442 2254 1216
Western : Manakalya, 4 th Floor, NTH Complex (W Sector), F-10, MIDC, Andheri (East), Mumbai 400093	{ 283 25838

Branches : AHMEDABAD, BENGALURU, BHOPAL, BHUBANESHWAR, CHANDIGARH, CHENNAI, COIMBATORE, DEHRADUN, DELHI, FARIDABAD, GHAZIABAD, GUWAHATI, HARYNA, HUBLI, HYDERABAD, JAIPUR, JAMMU & KASHMIR, JAMSHEDPUR, KOCHI, KOLKATA, LUCKNOW, MADURAI, MUMBAI, NAGPUR, NOIDA, PARWANOO, PATNA, PUNE, RAIPUR, RAJKOT, SURAT, VIJAYAWADA.