

सिगरेट — सिगरेट के मेनस्ट्रीम स्मोक में
चयनित कार्बोनिल का निर्धारण — उच्च
दक्षता द्रव क्रोमैटोग्राफी पद्धति

Cigarettes — Determination of
Selected Carbonyls in the
Mainstream Smoke of Cigarettes —
Method Using High Performance
Liquid Chromatography

ICS 65.160

© BIS 2024

© ISO 2018



भारतीय मानक ब्यूरो
BUREAU OF INDIAN STANDARDS
मानक भवन, 9 बहादुर शाह ज़फर मार्ग, नई दिल्ली - 110002
MANAK BHAVAN, 9 BAHADUR SHAH ZAFAR MARG
NEW DELHI - 110002

www.bis.gov.in www.standardsbis.in

NATIONAL FOREWORD

This Indian Standard which is identical to ISO 21160 : 2018 'Cigarettes — Determination of selected carbonyls in the mainstream smoke of cigarettes — Method using high performance liquid chromatography' issued by the International Organization for Standardization (ISO) was adopted by the Bureau of Indian Standard on recommendation of the Tobacco and Tobacco Products Sectional Committee and approval of the Food and Agriculture Division Council.

The text of ISO standard has been approved as suitable for publication as an Indian Standard without deviations. Certain conventions are, however, not identical to those used in Indian Standards. Attention is particularly drawn to the following:

- a) Wherever the words 'International Standard' appear referring to this standard, they should be read as 'Indian Standard'; and
- b) Comma (,) has been used as a decimal marker while in Indian Standards, the current practice is to use a point (.) as the decimal marker.

In this adopted standard, reference appears to the following International Standards for which Indian Standard also exists. The corresponding Indian Standards which are to be substituted in their respective places, are listed below along with their degree of equivalence for the editions indicated:

<i>International Standard</i>	<i>Corresponding Indian Standard</i>	<i>Degree of Equivalence</i>
ISO 3308 Routine analytical cigarette-smoking machine — Definitions and standard conditions	IS 16022 : 2015/ISO 3308 : 2012 Routine analytical cigarette-smoking machine — Definitions and standard conditions (<i>first revision</i>)	Identical
ISO 3402 Tobacco and tobacco products — Atmosphere for conditioning and testing	IS 16124 : 2023/ISO 3402: 2023 Tobacco and tobacco products — Atmosphere for conditioning and testing (<i>first revision</i>)	Identical
ISO 4387 Cigarettes — Determination of total and nicotine-free dry particulate matter using a routine analytical smoking machine	IS 16023 : 2021/ISO 4387 : 2019 Cigarettes — Determination of total and nicotine-free dry particulate matter using a routine analytical smoking machine (<i>first revision</i>)	Identical
ISO 8243 Cigarettes — Sampling	IS 12942 : 2018/ISO 8243 : 2013 Cigarettes — Sampling (<i>third revision</i>)	Identical

In reporting the results of a test or analysis made in accordance with this standard, if the final value, observed or calculated, is to be rounded off, it shall be done in accordance with IS 2 : 2022 'Rules for rounding off numerical values (*second revision*)'.

Contents

Page

Introduction	iv
1 Scope	1
2 Normative references	1
3 Terms and definitions	1
4 Principle	1
5 Apparatus	2
6 Reagents	3
7 Preparation	4
7.1 Preparation of glassware.....	4
7.2 Preparation of solutions.....	4
7.3 Preparation of standards.....	4
7.3.1 HPLC calibration standards and working solutions.....	4
7.3.2 Carbonyl working standards.....	5
8 Sampling	5
9 Tobacco product preparation	5
10 Sample generation — Smoking of cigarettes	5
10.1 General.....	5
10.2 Smoking machine setup.....	5
10.3 Smoking.....	6
10.3.1 General.....	6
10.3.2 Linear smoking.....	6
10.3.3 Rotary smoking.....	7
11 Sample analysis	7
11.1 Preparation of mainstream smoke extract solution.....	7
11.2 Reversed phase high performance liquid chromatography.....	7
11.2.1 Chromatographic conditions.....	7
11.2.2 Mobile phase reagents.....	7
11.2.3 HPLC separation conditions.....	8
11.3 Calculation.....	8
11.3.1 Calibration curve.....	8
11.3.2 Sample quantification.....	8
12 Repeatability and reproducibility	9
12.1 General.....	9
12.2 Results from the 2012 collaborative study.....	9
13 Test report	12
Annex A (informative) Recrystallization of 2,4-dinitrophenylhydrazine	13
Annex B (normative) Example of calibration standards preparation	14
Annex C (informative) HPLC chromatogram of a typical combined carbonyl calibration standard	15
Annex D (informative) HPLC chromatogram of carbonyls in DNPH extract of mainstream cigarette smoke	16
Bibliography	17

Introduction

At the outset of this work, discussions in the CORESTA (www.coresta.org) Special Analytes Sub-Group (since 2017 the Sub-Group changed its name to Smoke Analytes) determined that most laboratories used a method involving derivatization of carbonyls with 2,4-dinitrophenylhydrazine (DNPH) because they considered it the most suitable. This was chosen as the basis of the CORESTA Recommended Method (CRM). The CRM comprised smoke collection in impinger traps, derivatization of carbonyls with DNPH followed by their determination using reversed phase High Performance Liquid Chromatography with Ultra Violet or Diode Array Detection (HPLC-UV or HPLC-DAD).

Initial joint experiments and ongoing discussions addressed some methodological aspects that needed to be evaluated before the drafting of a CRM. This method was produced through a collaborative study undertaken in 2010 involving 15 laboratories from 11 countries using the ISO 3308 smoking regime^[1]. Further data are provided for the same selected carbonyl compounds from 10 samples with different tar yields from the collaborative study in 2012, which involved 19 laboratories from 11 countries^[2].

This method includes recommendations about some of the critical steps that should be controlled to provide data as robust and consistent as the repeatability and reproducibility data provided in the ISO document. Statistical evaluations were carried out according to ISO 5725-1 and ISO 5725-2^{[3],[4]}.

No machine smoking regime can represent all human smoking behaviour.

- It is recommended that cigarettes also be tested under conditions of a different intensity of machine smoking than those specified in this document.
- Machine smoking testing is useful to characterize cigarette emissions for design and regulatory purposes, but communication of machine measurements to smokers can result in misunderstandings about differences in exposure and risk across brands.
- Smoke emission data from machine measurements may be used as inputs for product hazard assessment, but they are not intended to be nor are they valid as measures of human exposure or risks. Communicating differences between products in machine measurements as differences in exposure or risk is a misuse of testing using ISO standards.

Indian Standard

CIGARATTES — DETERMINATION OF SELECTED CARBONYLS IN THE MAINSTREAM SMOKE OF CIGARETTES — METHOD USING HIGH PERFORMANCE LIQUID CHROMATOGRAPHY

WARNING — The use of this document can involve hazardous materials, operations and equipment. This document does not purport to address all the safety problems associated with its use. It is the responsibility of the user of this document to establish appropriate safety and health practices, and determine the applicability of any other restrictions prior to use.

1 Scope

This document specifies a method for the determination of selected carbonyls (formaldehyde, acetaldehyde, acetone, acrolein, propionaldehyde, crotonaldehyde, 2-butanone and *n*-butyraldehyde) as their 2,4-dinitrophenylhydrazones in mainstream smoke using reversed phase HPLC-UV/DAD.

This method is applicable to cigarettes with nicotine-free dry particulate matter (NFDPM) yields between 1 mg/cigarette and 15 mg/cigarette using reversed phase HPLC-UV/DAD.

2 Normative references

The following documents are referred to in the text in such a way that some or all of their content constitutes requirements of this document. For dated references, only the edition cited applies. For undated references, the latest edition of the referenced document (including any amendments) applies.

ISO 3308, *Routine analytical cigarette-smoking machine — Definitions and standard conditions*

ISO 3402, *Tobacco and tobacco products — Atmosphere for conditioning and testing*

ISO 4387, *Cigarettes — Determination of total and nicotine-free dry particulate matter using a routine analytical smoking machine*

ISO 8243, *Cigarettes — Sampling*

3 Terms and definitions

No terms and definitions are listed in this document.

ISO and IEC maintain terminological databases for use in standardization at the following addresses:

- ISO Online browsing platform: available at <https://www.iso.org/obp>
- IEC Electropedia: available at <http://www.electropedia.org/>

4 Principle

Cigarettes are smoked on a standard smoking machine as specified in ISO 3308 that has been fitted with impingers, but without a glass fibre filter pad as described in ISO 3308 (Cambridge filter pad; CFP, for example of equivalent product) and the filter pad holder, under the ISO 3308 smoking regime.

The carbonyls in mainstream tobacco smoke are trapped by passing each puff through an impinger device containing an acidified solution of 2,4-dinitrophenylhydrazine (DNPH) in 1:1 acetonitrile:water.

An aliquot of the smoke extract is then syringe-filtered and diluted with 1 % tris-(hydroxymethyl)-aminomethane in aqueous acetonitrile.

The samples are subjected to analysis using reversed phase HPLC-UV or HPLC-DAD.

5 Apparatus

The usual laboratory apparatus for use in preparation of samples, solutions and standards and, in particular, the following.

- 5.1 **Equipment for conditioning of tobacco products.**
- 5.2 **Equipment for butt length marking.**
- 5.3 **Equipment for smoking of tobacco products**, complying with ISO 3308.
- 5.4 **Impingers for trapping mainstream smoke.**
- 5.5 **Erlenmeyer flasks**, of capacities 150 ml, with ground glass stoppers, (or equivalent for combining impinger solutions).
- 5.6 **Polyvinylchloride (PVC) tubing**, suitable for connection of the trapping system.
- 5.7 **Analytical balance**, capable of measuring to four decimal places.
- 5.8 **Amber glass volumetric flasks**, of capacities 10 ml, 25 ml, 200 ml, 1 l and 2 l.
- 5.9 **Glass micropipettes**, of capacities 50 µl, 100 µl, 150 µl, 300 µl, 400 µl, 500 µl, 800 µl, 1 000 µl and 2 000 µl.
- 5.10 **Volumetric pipettes**, of capacities 1 ml, 2 ml, 5 ml, 6 ml, 7 ml, 8 ml and 20 ml.
- 5.11 **Glass graduated measuring cylinders**, of capacities 25 ml, 50 ml and 100 ml.
- 5.12 **Dispenser**, capable of delivering 35 ml.
- 5.13 **Hot plate/stirrer.**
- 5.14 **Syringe filter**, 0,45 µm PVDF or equivalent.
- 5.15 **Disposable syringes**, 5 ml.
- 5.16 **Disposable glass Pasteur pipettes.**
- 5.17 **Rubber bulbs.**
- 5.18 **Autosampler vials**, caps and PTFE faced septa.
- 5.19 **HPLC system**, consisting of:
 - tertiary gradient pump;
 - auto-sampler with appropriate sampling loop;
 - UV and/or DAD detector;

- data collection system;
- LC column: 250 mm × 4 mm, 100 Å, Reversed Phase (RP) 18e (5 µm), or equivalent;
- disposable guard column: 4 mm × 4 mm RP 18e (5 µm), or equivalent;
- vacuum filter;
- amber glass bottles 1 l and 4 l;
- desiccator;
- degasser (optional).

6 Reagents

- 6.1 **Acetonitrile**, MeCN, HPLC grade.
- 6.2 **Isopropanol**, IPA, HPLC grade.
- 6.3 **Ethyl acetate**, HPLC grade.
- 6.4 **Tetrahydrofuran**, THF, HPLC grade.
- 6.5 **Ethanol**, HPLC grade.
- 6.6 **Phosphoric acid**, 85 %.
- 6.7 **Deionized water**, resistivity > 18,0 MΩ.cm at 25 °C.
- 6.8 **Formaldehyde-DNPH**, min. 99 %.
- 6.9 **Acetaldehyde-DNPH**, min. 99 %.
- 6.10 **Acetone-DNPH**, min. 99 %.
- 6.11 **Acrolein-DNPH**, min. 99 %.
- 6.12 **Propionaldehyde-DNPH**, min. 98 %.
- 6.13 **Crotonaldehyde-DNPH**, min. 99 %.
- 6.14 **2-Butanone-DNPH**, min. 98 %; methyl ethyl ketone-DNPH derivative.
- 6.15 **n-Butyraldehyde-DNPH**, min. 99 %.
- 6.16 **Tris-(hydroxymethyl)-aminomethane**, ACS reagent grade¹⁾.
- 6.17 **2,4-Dinitrophenylhydrazine (DNPH)**.

1) A reagent that meets the requirements of the American Chemical Society (ACS) Committee on Analytical Reagents.

6.18 Helium, (UHP), if necessary for sparging of HPLC system mobile phase or equivalent degassing system.

7 Preparation

7.1 Preparation of glassware

Glassware shall be cleaned and dried in such a manner as to ensure that contamination from glassware does not occur.

All possible sources of contamination shall be removed from the work area (e.g. acetone solvent wash bottles).

7.2 Preparation of solutions

7.2.1 DNPH solution (using phosphoric acid)

Add approximately 150 ml deionized water to a 200 ml volumetric flask, then carefully add 28 ml of 85 % phosphoric acid and mix the solution.

Make up the solution to volume with deionized water.

Weigh approximately 6,8 g (24,0 mmol should be achieved) of DNPH (approximately 30 % water) into a 2 l amber volumetric flask and add 1 l of acetonitrile. Dissolve DNPH by alternately gently swirling the flask. Make sure there are no crystals remaining.

WARNING — Do not sonicate as a precipitation of DNPH may occur.

If using re-crystallized DNPH, weigh 4,8 g to achieve the same molarity (see [Annex A](#)).

After the DNPH is dissolved, add 58 ml of the diluted phosphoric acid solution while gently mixing. Dilute to volume with deionized water. The colour of the solution will become bright orange upon addition of the deionized water.

The addition of acid or water will cool the solution and may initiate the precipitation of the DNPH. Add the acid or water slowly. Gentle swirling may be required to maintain the solution at room temperature and to prevent the precipitation of DNPH. If crystals appear, do not sonicate.

Store the solution in a 4 l amber bottle at room temperature in the dark to prevent or significantly reduce the chances of DNPH precipitation. This solution, if properly sealed, will remain stable for one week.

7.2.2 Tris-(hydroxymethyl)-aminomethane dilution solution, 80:20 (volume fraction), MeCN: 1 % aqueous solution.

Dissolve 2,00 g of tris-(hydroxymethyl)-aminomethane in 200 ml of deionized water in a 1 l volumetric flask. Dilute to volume with acetonitrile.

Store in a 1 l amber bottle with PTFE-lined cap or equivalent at ambient temperature.

7.3 Preparation of standards

7.3.1 HPLC calibration standards and working solutions

The calibration should cover the concentration range of interest.

7.3.1.1 Primary carbonyl standards

Weigh the hydrazones as described in [Annex B](#) into individual 25 ml volumetric flasks and dissolve in acetonitrile. Record the concentrations of the free aldehyde equivalents in µg/ml.

These solutions have been shown to be stable for up to one year when stored at approximately 4 °C. Stability and storage time should be checked by the laboratory.

7.3.1.2 Secondary carbonyl standards

Pipette predetermined volumes ([Annex B](#)) of each primary hydrazone standard into a 25 ml volumetric flask and dilute to the mark with acetonitrile.

Store at approximately 4 °C. Stability and storage time should be checked by the laboratory.

7.3.2 Carbonyl working standards

Take appropriate volumes (0,050 ml to 10 ml) of the secondary carbonyl standard ([7.3.1.2](#)) and dilute to 10 ml with acetonitrile to prepare calibration standards with approximate carbonyl concentrations (see [Annex B](#)).

Transfer to auto-sampler vials.

The calibration range described in [Annex B](#) has been shown to be suitable; however, it can be necessary to adjust the calibration range depending on factors such as the number of cigarettes smoked and the carbonyl yields of the test cigarettes. The user shall ensure the low calibration standard has a sufficient signal to noise ratio for accurate quantitation ($\geq 10:1$) and that the calibration curve is linear.

These solutions have been shown to be stable for 20 days when stored at approximately 4 °C. Stability and storage time should be checked by the laboratory.

8 Sampling

Carry out sampling in accordance with ISO 8243.

9 Tobacco product preparation

Condition the cigarettes in accordance with ISO 3402.

10 Sample generation — Smoking of cigarettes

10.1 General

The smoking parameters for which the method has been studied are defined in ISO 3308. See [Table 1](#).

Table 1 — Smoking parameters for ISO smoking regime

Smoking regime	Puff volume (ml)	Puff frequency (s)	Puff duration (s)	Ventilation blocking (%)
ISO 3308	35	60	2	0

10.2 Smoking machine setup

An analytical cigarette smoking-machine complying with the requirements of ISO 3308 is required with the following modifications as detailed below.

No filter pad is required in the set up and therefore puff count information is the only means of monitoring whether the smoking process is controlled.

Add 35 ml of DNPH solution to each impinger. Assemble the carbonyl mainstream apparatus on the smoking machine without using the filter pads and filter holders (Figure 1).

A volume other than 35 ml of DNPH solution may need to be added to each impinger depending on the particular style of impinger used.

Check and adjust the puff volume drawn by the smoking machine at all channels at the cigarette end of the port as described in ISO 4387 with the impingers and DNPH in line.

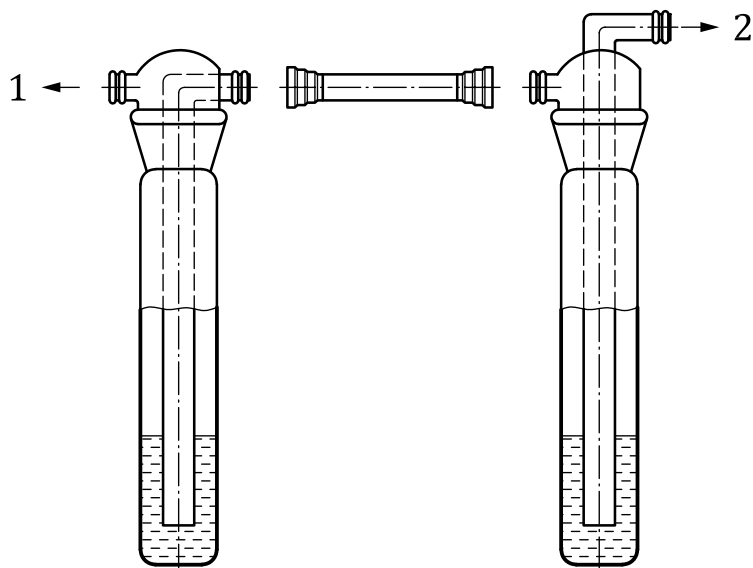

Key

- 1 attached to tubing leading to piston
- 2 back of cigarette holder

Figure 1 — Example of a suitable trapping system

Since there is no standard impinger design, trapping efficiency shall be verified when validating this method. The trapping system should effectively trap 95 % of the analytes of interest. To check the trapping efficiency of the method, add an additional backup impinger and follow the method accordingly. Analyse each impinger individually for the compounds of interest. If no compounds are detected in the backup impinger then only the prescribed number of impingers is required to trap all the carbonyls effectively. Breakthrough or poor trapping efficiency can be due to the design of the impinger or cigarettes with high carbonyl yields.

To determine whether a leak has occurred in the smoking machine impinger setup, use a leak tester. If the fluid column does not maintain its position but drops then there is a leak in the system.

10.3 Smoking

10.3.1 General

The cigarettes are smoked according to ISO smoking regime in ISO 3308 with the modifications given in 10.3.2 and 10.3.3.

10.3.2 Linear smoking

Two cigarettes are smoked per replicate.

10.3.3 Rotary smoking

Five cigarettes are smoked per replicate.

The number of cigarettes smoked may be adjusted to bring the samples within the calibration range.

11 Sample analysis

11.1 Preparation of mainstream smoke extract solution

Rinse the tubing with the impinger solution by forcing the solution back up the impinger, e.g. by using positive air pressure, then with negative air pressure until air is drawn back through the solution.

Repeat this rinsing procedure at least three times for each impinger to dissolve any smoke condensate in the gas transfer lines.

Allow the DNPH smoke extract solution to sit for five to 30 min^[4] before continuing with sample preparation.

Pipette 5 ml of 1 % tris-(hydroxymethyl)-aminomethane solution into a 10 ml volumetric flask.

Add 4 ml of syringe-filtered DNPH smoke extract to the volumetric flask.

Fill up to the mark with tris-(hydroxymethyl)-aminomethane solution and mix the volumetric flask well. Transfer a portion of this solution to an auto-sampler vial.

Cap the vials with PTFE faced septa and store at ambient temperature until analysed.

Repeat above steps for each smoke extract sample.

11.2 Reversed phase high performance liquid chromatography

11.2.1 Chromatographic conditions

These settings are detector-dependent. In order to achieve a linear response over the concentration range of analytes of interest modification can be necessary.

EXAMPLE

- Column temperature: 30 °C
- Auto-sampler tray temperature: ambient
- Injection volume: 20 µl
- UV or DAD detection: at 365 nm

11.2.2 Mobile phase reagents

- **Solvent A:** Prepare 2 l of 30 % acetonitrile, 10 % THF, 1 % IPA in deionized water, filter and degas (UHP helium sparged)
- **Solvent B:** Prepare 2 l of 65 % acetonitrile, 1 % THF, 1 % IPA in deionized water, filter and degas (UHP helium sparged)
- **Solvent C:** Acetonitrile (UHP helium sparged)

NOTE Depending on column differences or resolution of the analytes, adjustments to the mobile phase can be necessary.

- Sample wash: Solvent A

11.2.3 HPLC separation conditions

Standards and samples are analysed by HPLC operated at a flow rate of 1,5 ml/min ([Table 2](#)). The injection volume is 20 µl.

Table 2 — HPLC Mobile phase gradient

Time (min)	Composition		
0,0	100 % A	0 % B	0 % C
8,0	70 % A	30 % B	0 % C
20,0	47 % A	53 % B	0 % C
27,0	0 % A	100 % B	0 % C
30,0	0 % A	0 % B	100 % C
32,0	0 % A	0 % B	100 % C
34,0	95 % A	5 % B	0 % C
Method end	—	—	—
Equilibrate for 10 min	100 % A	0 % B	0 % C

The chromatographic conditions can be different for different instrument configurations and columns. However, as a general system suitability check, the elution pattern should be similar to the example chromatograms shown in [Annex C \(Figure C.1\)](#) and [Annex D \(Figure D.1\)](#).

11.3 Calculation

11.3.1 Calibration curve

Generate a calibration curve for each individual carbonyl by plotting standards peak areas against their respective concentrations.

11.3.2 Sample quantification

The concentration of selected carbonyls in smoke samples is quantified by the external standard method. An example of a typical chromatogram is shown in [Annex D](#). The identification of peaks is by comparison of retention times with standards, and the spiking of smoke samples.

Carbonyl concentrations are reported in micrograms per millilitre by the chromatography software.

The amount of carbonyl yields in the mainstream smoke of cigarettes, m_c , expressed in micrograms per cigarette, is given by [Formula \(1\)](#):

$$m_c = [A] d \frac{V}{N_{\text{cig}}} \quad (1)$$

where

[A] is the concentration of the analyte, in micrograms per millilitre, from the linear regression reported by the software;

d is the dilution factor (final volume/aliquot volume);

V is the impinger volume;

N_{cig} is the number of cigarettes smoked.

NOTE It was observed that under the conditions chosen for the derivatization an isomerization of acetaldehyde hydrazone occurs. The resulting additional isomer can be separated by HPLC and elutes under the described separation conditions in front of the main isomer ([Annex D](#)).

For the calculation of acetaldehyde yield, the area of both isomers should be calculated to obtain correct results.

If the carbonyls yields are above the top calibration standard, and the trapping efficiency was demonstrated to be sufficient, the sample should be diluted to fit into the calibration curve and re-analysed. It is recommended to dilute the sample using the same DNPH trapping solution and base (in the same ratio as in the sample).

The expression of the laboratory data depends on the purpose for which the data are required, and the level of laboratory precision. Any further statistical analyses should be calculated and expressed on the basis of the laboratory data before any rounding has taken place.

Carbonyl yields in the mainstream smoke of cigarette in units of microgram per cigarette ($\mu\text{g}/\text{cig}$) shall be reported rounded to the nearest 0,1 μg .

12 Repeatability and reproducibility

12.1 General

A collaborative study was conducted in 2012 involving 19 laboratories and 10 cigarette samples. This provided data on the measurement of the same selected carbonyls in five replicate analyses of 10 samples (see [Table 3](#)) performed under the ISO smoking regime (ISO 3308). The values^[5] for repeatability, r , and reproducibility, R , given in [Tables 4](#) to [11](#), were obtained for this method. The statistical evaluation was performed according to ISO 5725-2.

Table 3 — Cigarette test samples of the 2012 collaborative study

Sample	Product characterization	NFDPM yield (mg/cigarette)
Sample 1	Dark air-cured product	10
Sample 2	American blended product	8
Sample 3	American blended product	6
Sample 4	Virginia blended product	4
Sample 5	Virginia blended product	2
Sample 6	Virginia blended product	10
Sample 7	Charcoal filtered/blended product	1
3R4F	Kentucky Reference 3R4F/American blend	8
1R5F	Kentucky Reference 1R5F/American blend	2
CM6	CORESTA Monitor Test Piece CM6/Virginia blend	15

12.2 Results from the 2012 collaborative study

Results from the collaborative study including NFDPM yields, number of laboratories included in the study, mean yields obtained from ISO smoking regime (ISO 3308) and calculated statistical data for the individual carbonyls are given in [Tables 4](#) to [11](#).

Table 4 — Formaldehyde

Sample description	NFDPM yield (mg/cigarette)	N ^a	Mean	<i>r</i>	<i>R</i>
			(µg/cigarette)		
CM6	15	17	47,2	8,5	22,3
1R5F	2	18	3,7	1,2	2,9
3R4F	8	19	20,9	4,5	10,2
1	10	14	14,2	4,0	9,4
2	8	14	19,0	5,5	9,7
3	6	13	15,7	3,5	8,4
4	4	15	15,5	4,6	10,7
5	2	15	6,6	2,5	5,7
6	10	14	70,5	16,3	42,6
7	1	14	3,2	2,1	3,4

^a *N* = number of data sets taken for statistical analysis after removal of outliers.

Table 5 — Acetaldehyde

Sample description	NFDPM yield (mg/cigarette)	N ^a	Mean	<i>r</i>	<i>R</i>
			(µg/cigarette)		
CM6	15	17	694,2	81,5	193,3
1R5F	2	19	143,6	35,9	102,3
3R4F	8	18	552,4	75,6	147,2
1	10	14	489,2	86,4	170,9
2	8	14	508	77,2	150,6
3	6	14	396,1	62,4	129,7
4	4	14	189,4	44,0	79,1
5	2	14	100	23,9	51,5
6	10	15	577,4	121	171,8
7	1	15	93,2	37,8	48,5

^a *N* = number of data sets taken for statistical analysis after removal of outliers.

Table 6 — Acetone

Sample description	NFDPM yield (mg/cigarette)	N ^a	Mean	<i>r</i>	<i>R</i>
			(µg/cigarette)		
CM6	15	18	269	38,3	94,6
1R5F	2	18	63,5	16,0	54,3
3R4F	8	19	209,7	33,1	91,2
1	10	15	193,7	42,6	93,4
2	8	14	190,8	31,8	100,4
3	6	14	154,4	23,8	67,9
4	4	15	77,0	21,4	49,7
5	2	13	38,7	10,8	20,3
6	10	15	227,2	50,4	94,5
7	1	14	42,8	21,1	39,0

^a *N* = number of data sets taken for statistical analysis after removal of outliers.

Table 7 — Acrolein

Sample description	NFDPM yield (mg/cigarette)	N ^a	Mean	<i>r</i>	<i>R</i>
			(µg/cigarette)		
CM6	15	17	68,5	10,7	19,4
1R5F	2	17	9,3	2,3	5,8
3R4F	8	18	48,3	8,9	16,7
1	10	14	36,4	7,5	16,6
2	8	15	43,6	10,2	18,4
3	6	14	31,8	6,7	13,7
4	4	15	18,4	5,4	10,3
5	2	14	9,5	3,1	6,6
6	10	15	62,6	15,7	23,1
7	1	15	7,0	3,4	4,5

^a N = number of data sets taken for statistical analysis after removal of outliers.

Table 8 — Propionaldehyde

Sample description	NFDPM yield (mg/cigarette)	N ^a	Mean	<i>r</i>	<i>R</i>
			(µg/cigarette)		
CM6	15	17	53,1	6,8	17,1
1R5F	2	19	12,0	2,7	7,0
3R4F	8	19	42,1	7,1	14,1
1	10	15	36,1	9,1	15,8
2	8	14	38,4	6,3	12,2
3	6	14	29,6	5,4	9,4
4	4	15	14,8	4,4	8,1
5	2	15	8,1	2,3	5,2
6	10	15	44,6	9,6	17,7
7	1	15	7,8	2,8	4,8

^a N = number of data sets taken for statistical analysis after removal of outliers.

Table 9 — Crotonaldehyde

Sample description	NFDPM yield (mg/cigarette)	N ^a	Mean	<i>r</i>	<i>R</i>
			(µg/cigarette)		
CM6	15	18	20,5	3,6	11,1
1R5F	2	15	2,4	1,1	2,0
3R4F	8	18	11,0	2,9	6,4
1	10	14	13,9	3,6	8,0
2	8	14	11,1	2,8	5,5
3	6	13	7,8	2,2	4,2
4	4	14	4,4	1,5	2,8
5	2	14	2,3	1,1	1,5
6	10	14	18,4	4,8	9,8
7	1	14	1,9	0,9	2,2

^a N = number of data sets taken for statistical analysis after removal of outliers.

Table 10 — 2-butanone

Sample description	NFDPM yield (mg/cigarette)	N ^a	Mean	<i>r</i>	<i>R</i>
			(µg/cigarette)		
CM6	15	18	62,1	12,7	36,0
1R5F	2	19	13,6	3,8	13,7
3R4F	8	18	51,7	8,3	24,3
1	10	15	45,3	12,4	30,6
2	8	14	47,3	10,2	15,9
3	6	14	35,8	7,9	25,3
4	4	14	17,1	4,3	13,1
5	2	15	10,0	3,8	9,8
6	10	14	54,6	15,3	39,4
7	1	15	9,1	3,8	9,5

^a *N* = number of data sets taken for statistical analysis after removal of outliers.

Table 11 — 2-butyraldehyde

Sample description	NFDPM yield (mg/cigarette)	N ^a	Mean	<i>r</i>	<i>R</i>
			(µg/cigarette)		
CM6	15	17	36,9	4,5	19,9
1R5F	2	18	7,7	2,1	5,8
3R4F	8	18	25,3	3,4	9,3
1	10	13	21,9	4,7	12,0
2	8	13	24,3	3,7	11,0
3	6	14	19,6	3,7	10,2
4	4	14	9,7	2,6	5,5
5	2	13	6,1	1,6	2,9
6	10	13	30,2	5,3	11,6
7	1	14	5,0	1,9	2,6

^a *N* = number of data sets taken for statistical analysis after removal of outliers.

13 Test report

The test report shall state all tested product(s) each with unique identification, reference to the smoking regime used for sample generation, the yield of selected carbonyls in micrograms per cigarette smoked, and the method used. The test report shall include all conditions and deviations which can affect the result. All information should be recorded in fully traceable manner.

Annex A (informative)

Recrystallization of 2,4-dinitrophenylhydrazine

The supplied DNPH can contain contaminants or impurities. In this case, recrystallization of DNPH is recommended.

Weigh approximately 35 g of DNPH into a weighing boat. Transfer the DNPH into a clean 2 l Erlenmeyer flask and add a stirrer.

Add 750 ml of anhydrous reagent grade ethanol to the flask. Place the flask on a hot plate equipped with a stirrer. Gently heat the solution with constant stirring.

When the solution is warm, slowly add 1 000 ml of ethyl acetate. Continue to heat and stir (making sure not to boil) until all of the DNPH is completely dissolved. The solution should be clear and a very dark red.

Vacuum filter the hot solution.

Transfer the filtrate to a 2 l Erlenmeyer flask.

If crystallization does not start to occur, scratch the inside of the flask with a glass rod. Cover the Erlenmeyer flask with a watch glass and allow the solution to cool overnight in a cupboard.

Vacuum filter the recrystallized DNPH.

Transfer the crystals into a clean weighing boat that is labelled with the date of recrystallization and the lot of the DNPH. Weigh the recrystallized DNPH. Place the crystals in a desiccator to remove any moisture.

The filtrate can be evaporated down with a rotovap and vacuum filtered again to recover more crystals.

If recrystallizing a larger quantity of DNPH (requirement of more than 2 days), the DNPH shall be hydrated to approximately 30 % with water. After adding the water, place in an airtight container and label it as containing 30 % water.

Annex B (normative)

Example of calibration standards preparation

Table B.1 — Stock standards

Carbonyl hydrazone	Formula Wt hydrazone	Formula Wt carbonyl	Primary standards				Secondary standard ^a			
			Mass	Purity	Volume	Stock	Volume of primary stock	Dilute to volume	Stock	
			(mg)	(%)	(ml)	(µg/ml)	(µl)	(ml)	(µg/ml)	
Formaldehyde	210,15	30,03	50,6	99,9	25	288,9	500	25	5,779	
Acetaldehyde	224,18	44,05	33,9	99,9	25	266,2	1 800	25	19,16	
Acetone	238,21	58,08	40,6	99,9	25	395,6	800	25	12,66	
Acrolein	236,18	56,06	17,7	99,9	25	167,9	850	25	5,708	
Propionaldehyde	238,21	58,08	35,8	99,9	25	348,8	500	25	6,976	
Crotonaldehyde	250,22	70,09	36,1	99,9	25	404,1	500	25	8,082	
MEK	252,23	72,11	33,4	99,9	25	381,6	500	25	7,631	
Butyraldehyde	252,23	72,11	42,8	99,9	25	489,0	1 000	25	19,56	

NOTE MEK = methyl ethyl ketone = 2-butanone.

^a In a single 25 ml volumetric flask, made to volume with acetonitrile.

Table B.2 — Carbonyl working standards

Carbonyl	Volume of secondary standard (ml) ^a							
	10,0	7,0	4,0	2,0	0,80	0,40	0,20	0,05
	(µg/ml)	(µg/ml)	(µg/ml)	(µg/ml)	(µg/ml)	(µg/ml)	(µg/ml)	(µg/ml)
Formaldehyde	5,779	4,045	2,311	1,156	0,462 3	0,231 1	0,115 6	0,028 9
Acetaldehyde	19,16	13,42	7,666	3,833	1,533	0,766 6	0,383 3	0,095 8
Acetone	12,66	8,861	5,063	2,532	1,013	0,506 3	0,253 2	0,063 3
Acrolein	5,708	3,996	2,283	1,142	0,456 6	0,228 3	0,114 2	0,028 5
Propionaldehyde	6,976	4,883	2,790	1,395	0,558 1	0,279 0	0,139 5	0,034 9
Crotonaldehyde	8,082	5,657	3,233	1,616	0,646 5	0,323 3	0,161 6	0,040 4
MEK	7,631	5,342	3,053	1,526	0,610 5	0,305 3	0,152 6	0,038 2
Butyraldehyde	19,56	13,69	7,823	3,912	1,565	0,782 3	0,391 2	0,097 8

NOTE MEK = methyl ethyl ketone = 2-butanone.

^a In a single 10 ml volumetric flask, made to volume with acetonitrile.

Annex C (informative)

HPLC chromatogram of a typical combined carbonyl calibration standard

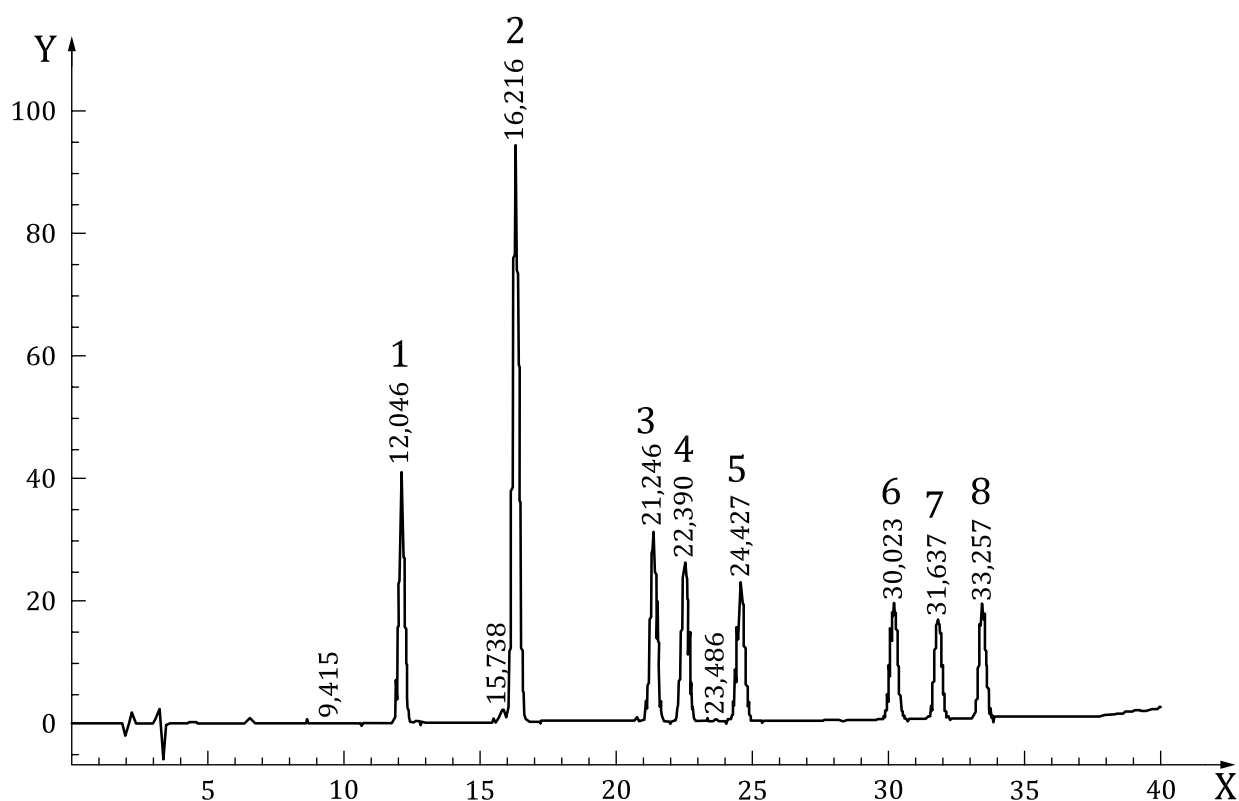

Key

- X time, min
- Y abundance
- 1 formaldehyde—DNPH
- 2 acetaldehyde—DNPH
- 3 acetone—DNPH
- 4 acrolein—DNPH
- 5 propionaldehyde—DNPH
- 6 crotonaldehyde—DNPH
- 7 2-butanone—DNPH
- 8 butyraldehyde—DNPH

Figure C.1 — HPLC chromatogram of a typical combined carbonyl calibration standard using column AQ RP C 18, 5 μ m, 250 mm \times 4,6 mm

Annex D (informative)

HPLC chromatogram of carbonyls in DNPH extract of mainstream cigarette smoke

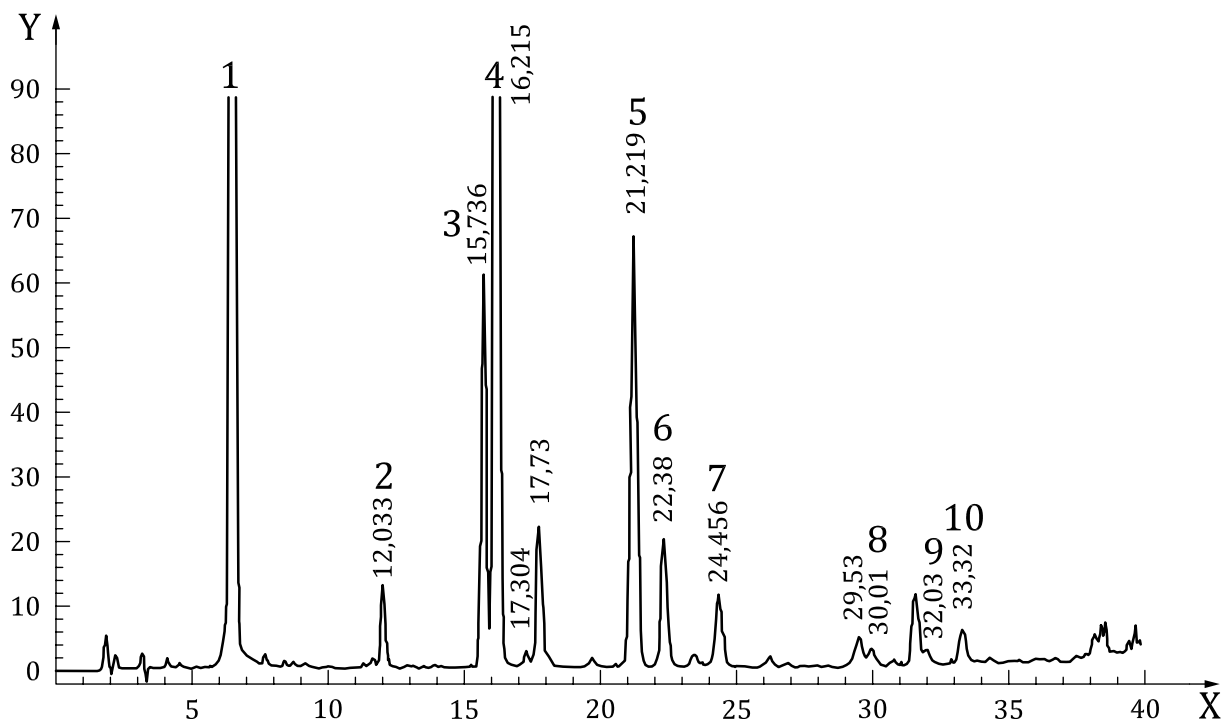

Key

- X time, min
- Y abundance
- 1 DNPH
- 2 formaldehyde—DNPH
- 3 isomer acetaldehyde—DNPH
- 4 acetaldehyde—DNPH
- 5 acetone—DNPH
- 6 acrolein—DNPH
- 7 propionaldehyde—DNPH
- 8 crotonaldehyde—DNPH
- 9 2-butanone—DNPH
- 10 butyraldehyde—DNPH

Figure D.1 — HPLC chromatogram of carbonyls in DNPH extract of mainstream tobacco smoke of 3R4F using column AQ RP C 18, 5 μ m, 250 mm \times 4,6 mm

Bibliography

- [1] INTORP M., PURKIS S.W., WAGSTAFF W. 2012: Determination of carbonyl compounds in cigarette mainstream smoke: The CORESTA 2010 Collaborative Study and Recommended Method. *Beiträge zur Tabakforschung International/Contributions to Tobacco Research*, **25** (2), pp. 361-374
- [2] PURKIS S.W., INTORP M., HAULEITHNER A. 2013: Updates of CORESTA Recommended Methods after Further Collaborative Studies Carried Out under Both ISO and Health Canada Intense Smoking Regimes, *Beiträge zur Tabakforschung International/Contributions to Tobacco Research*, **25** (8), pp. 700-707
- [3] ISO 5725-1:1994, *Accuracy (trueness and precision) of measurement methods and results — Part 1: General principles and definitions*
- [4] ISO 5725-2:1994, *Accuracy (trueness and precision) of measurement methods and results — Part 2: Basic method for the determination of repeatability and reproducibility of a standard measurement method*
- [5] CORESTA Recommended Method (CRM) No. 74 — *Determination of Selected Carbonyls in Mainstream Cigarette Smoke by High Performance Liquid Chromatography (HPLC)*. Available at: www.coresta.org

Bureau of Indian Standards

BIS is a statutory institution established under the *Bureau of Indian Standards Act, 2016* to promote harmonious development of the activities of standardization, marking and quality certification of goods and attending to connected matters in the country.

Copyright

BIS has the copyright of all its publications. No part of these publications may be reproduced in any form without the prior permission in writing of BIS. This does not preclude the free use, in the course of implementing the standard, of necessary details, such as symbols and sizes, type or grade designations. Enquiries relating to copyright be addressed to the Head (Publication & Sales), BIS.

Review of Indian Standards

Amendments are issued to standards as the need arises on the basis of comments. Standards are also reviewed periodically; a standard along with amendments is reaffirmed when such review indicates that no changes are needed; if the review indicates that changes are needed, it is taken up for revision. Users of Indian Standards should ascertain that they are in possession of the latest amendments or edition by referring to the website-www.bis.gov.in or www.standardsbis.in.

This Indian Standard has been developed from Doc No.: FAD 04 (23303).

Amendments Issued Since Publication

Amend No.	Date of Issue	Text Affected

BUREAU OF INDIAN STANDARDS

Headquarters:

Manak Bhavan, 9 Bahadur Shah Zafar Marg, New Delhi 110002

Telephones: 2323 0131, 2323 3375, 2323 9402

Website: www.bis.gov.in

Regional Offices:

	Telephones
Central : 601/A, Konnectus Tower -1, 6 th Floor, DMRC Building, Bhavbhuti Marg, New Delhi 110002	{ 2323 7617
Eastern : 8 th Floor, Plot No 7/7 & 7/8, CP Block, Sector V, Salt Lake, Kolkata, West Bengal 700091	{ 2367 0012 2320 9474
Northern : Plot No. 4-A, Sector 27-B, Madhya Marg, Chandigarh 160019	{ 265 9930
Southern : C.I.T. Campus, IV Cross Road, Taramani, Chennai 600113	{ 2254 1442 2254 1216
Western : Plot No. E-9, Road No.-8, MIDC, Andheri (East), Mumbai 400093	{ 2821 8093

Branches : AHMEDABAD. BENGALURU. BHOPAL. BHUBANESHWAR. CHANDIGARH. CHENNAI. COIMBATORE. DEHRADUN. DELHI. FARIDABAD. GHAZIABAD. GUWAHATI. HIMACHAL PRADESH. HUBLI. HYDERABAD. JAIPUR. JAMMU & KASHMIR. JAMSHEDPUR. KOCHI. KOLKATA. LUCKNOW. MADURAI. MUMBAI. NAGPUR. NOIDA. PANIPAT. PATNA. PUNE. RAIPUR. RAJKOT. SURAT. VISAKHAPATNAM.