



**International
Standard**

ISO 22705-3

**Springs — Measurement and test
parameters —**

Part 3:
**Cold formed cylindrical helical
torsion springs**

Ressort — Mesures et paramètres d'essai —

Partie 3: Ressorts à torsion cylindrique, enroulés à froid

**First edition
2024-04**



COPYRIGHT PROTECTED DOCUMENT

© ISO 2024

All rights reserved. Unless otherwise specified, or required in the context of its implementation, no part of this publication may be reproduced or utilized otherwise in any form or by any means, electronic or mechanical, including photocopying, or posting on the internet or an intranet, without prior written permission. Permission can be requested from either ISO at the address below or ISO's member body in the country of the requester.

ISO copyright office
CP 401 • Ch. de Blandonnet 8
CH-1214 Vernier, Geneva
Phone: +41 22 749 01 11
Email: copyright@iso.org
Website: www.iso.org

Published in Switzerland

Contents

	Page
Foreword	v
1 Scope	1
2 Normative references	1
3 Terms, definitions, symbols and abbreviated terms	1
3.1 Terms and definitions.....	1
3.2 Symbols and abbreviated terms.....	2
4 Environmental conditions	4
5 Qualifications of the person(s) performing the work	5
6 Geometries of guiding and supporting devices	5
7 Measuring and testing equipment	5
8 Measurement and test parameter for technical cold formed cylindrical torsion springs	5
8.1 Body length (L_B).....	5
8.1.1 General.....	5
8.1.2 Type of characteristic.....	5
8.1.3 Measuring and/or testing equipment.....	5
8.1.4 Conditions of measurement and testing.....	6
8.1.5 Method of measurement and testing.....	6
8.1.6 Test location on the product.....	7
8.2 Outside diameter (D_o).....	7
8.2.1 General.....	7
8.2.2 Type of characteristic.....	8
8.2.3 Measurement and/or testing equipment.....	8
8.2.4 Conditions of measurement and testing.....	8
8.2.5 Method of measurement and testing.....	8
8.2.6 Test location on the product.....	10
8.3 Inside diameter (D_i).....	10
8.3.1 General.....	10
8.3.2 Type of characteristic.....	11
8.3.3 Measurement and/or testing equipment.....	11
8.3.4 Conditions of measurement and testing.....	11
8.3.5 Method of measurement and testing.....	11
8.3.6 Test location on the product.....	13
8.4 Spring leg length (l).....	14
8.4.1 General.....	14
8.4.2 Type of characteristic.....	14
8.4.3 Measurement and/or testing equipment.....	14
8.4.4 Conditions of measurement and testing.....	15
8.4.5 Method of measurement and testing.....	15
8.4.6 Test location on the product.....	15
8.5 Number of coils (n) and coil direction.....	15
8.5.1 General.....	15
8.5.2 Type of characteristic.....	16
8.5.3 Measurement and/or testing equipment.....	16
8.5.4 Conditions of measurement and testing.....	16
8.5.5 Method of measurement and testing.....	16
8.5.6 Test location on the product.....	17
8.6 Bending radius on legs (r).....	17
8.6.1 General.....	17
8.6.2 Type of characteristic.....	17
8.6.3 Measurement and/or testing equipment.....	17
8.6.4 Conditions of measurement and testing.....	18
8.6.5 Method of measurement and testing.....	18

ISO 22705-3:2024(en)

	8.6.6 Test location on the product.....	18
8.7	Angle of bend on legs (φ).....	18
	8.7.1 General.....	18
	8.7.2 Type of characteristic.....	18
	8.7.3 Measurement and/or testing equipment.....	19
	8.7.4 Conditions of measurement and testing.....	19
	8.7.5 Method of measurement and testing.....	19
	8.7.6 Test location on the product.....	20
8.8	Spring pitch (p)/distance between the coils (u).....	20
	8.8.1 General.....	20
	8.8.2 Type of characteristic.....	20
	8.8.3 Measurement and/or testing equipment.....	21
	8.8.4 Conditions of measurement and testing.....	21
	8.8.5 Method of measurement and testing.....	21
	8.8.6 Test location on the product.....	21
8.9	Spring torque (M).....	21
	8.9.1 General.....	21
	8.9.2 Type of characteristic.....	21
	8.9.3 Measurement equipment.....	22
	8.9.4 Conditions of measurement.....	22
	8.9.5 Method of measurement.....	22
	8.9.6 Test location on the product.....	23
8.10	Free angle (γ_0).....	23
	8.10.1 General.....	23
	8.10.2 Type of characteristic.....	23
	8.10.3 Measurement and/or testing equipment.....	24
	8.10.4 Conditions of measurement and testing.....	24
	8.10.5 Method of measurement and testing.....	24
	8.10.6 Test location on the product.....	24
8.11	Shear-off burr.....	24
	8.11.1 General.....	24
	8.11.2 Type of characteristic.....	24
	8.11.3 Test equipment.....	25
	8.11.4 Conditions of testing.....	25
	8.11.5 Method of testing.....	25
	8.11.6 Test location on the product.....	25
Annex A (informative) Calculation of spring rate R_M		26
Annex B (informative) Type of legs		27
Annex C (informative) Measurement of the length of leg l		28
Annex D (informative) Offset of leg c		29
Bibliography		30

Foreword

ISO (the International Organization for Standardization) is a worldwide federation of national standards bodies (ISO member bodies). The work of preparing International Standards is normally carried out through ISO technical committees. Each member body interested in a subject for which a technical committee has been established has the right to be represented on that committee. International organizations, governmental and non-governmental, in liaison with ISO, also take part in the work. ISO collaborates closely with the International Electrotechnical Commission (IEC) on all matters of electrotechnical standardization.

The procedures used to develop this document and those intended for its further maintenance are described in the ISO/IEC Directives, Part 1. In particular, the different approval criteria needed for the different types of ISO document should be noted. This document was drafted in accordance with the editorial rules of the ISO/IEC Directives, Part 2 (see www.iso.org/directives).

ISO draws attention to the possibility that the implementation of this document may involve the use of (a) patent(s). ISO takes no position concerning the evidence, validity or applicability of any claimed patent rights in respect thereof. As of the date of publication of this document, ISO had not received notice of (a) patent(s) which may be required to implement this document. However, implementers are cautioned that this may not represent the latest information, which may be obtained from the patent database available at www.iso.org/patents. ISO shall not be held responsible for identifying any or all such patent rights.

Any trade name used in this document is information given for the convenience of users and does not constitute an endorsement.

For an explanation of the voluntary nature of standards, the meaning of ISO specific terms and expressions related to conformity assessment, as well as information about ISO's adherence to the World Trade Organization (WTO) principles in the Technical Barriers to Trade (TBT), see <http://www.iso.org/iso/foreword.html>.

This document was prepared by Technical Committee ISO/TC 227, *Springs*.

A list of all parts in the ISO 22705 series can be found on the ISO website.

Any feedback or questions on this document should be directed to the user's national standards body. A complete listing of these bodies can be found at www.iso.org/members.html.

Springs — Measurement and test parameters —

Part 3: Cold formed cylindrical helical torsion springs

1 Scope

This document specifies the measurement and test methods for general characteristics of cold formed cylindrical helical torsion springs made from round wire, excluding dynamic testing.

2 Normative references

There are no normative references in this document.

3 Terms, definitions, symbols and abbreviated terms

3.1 Terms and definitions

For the purposes of this document, the following terms and definitions apply.

ISO and IEC maintain terminology databases for use in standardization at the following addresses:

- ISO Online browsing platform: available at <https://www.iso.org/obp>
- IEC Electropedia: available at <https://www.electropedia.org/>

3.1.1

spring

mechanical device designed to store energy when deflected and to return the equivalent amount of energy when released

[SOURCE: ISO 26909:2009, 1.1]

3.1.2

torsion spring

spring that offers resistance to a twisting moment around the longitudinal axis of the spring

[SOURCE: ISO 26909:2009, 1.4]

3.1.3

coil spring

coil-shaped spring

[SOURCE: ISO 26909:2009, 3.11]

3.1.4

helical torsion spring

torsion spring normally made of wire of circular cross-section wound around an axis and with ends suitable for transmitting a twisting moment

[SOURCE: ISO 26909:2009, 3.14]

3.1.5

cold formed spring

spring formed at ambient temperature

[SOURCE: ISO 26909:2009, 1.12]

3.1.6

free angle

relative angle between both ends of a helical torsion spring when no load is applied

[SOURCE: ISO 26909:2009, 5.63]

3.1.7

torsional moment

torque

moment generated around the axis when external force is applied to a helical torsion spring

[SOURCE: ISO 26909:2009, 5.11]

3.1.8

spring characteristics

relationship between the load applied to a spring and the deflection caused by the load

[SOURCE: ISO 26909:2009, 5.1]

3.1.9

force

force exerted on or by a spring in order to reproduce or modify motion, or to maintain a system of forces in equilibrium

[SOURCE: ISO 26909:2009, 5.2]

3.1.10

test parameter

parameter with a tolerance for which there is an immediate conclusion after test (OK or not OK)

Note 1 to entry: Test can be done without measurement (i.e. with go/no-go gauges)

3.2 Symbols and abbreviated terms

[Table 1](#) includes the symbols and abbreviated terms used throughout this document.

Table 1 — Symbols and abbreviated terms

Symbols	Units	Designations
c	mm	offset of leg (see Annex D)
D_e	mm	outside diameter of spring
D_i	mm	inside diameter of spring
d	mm	diameter of wire
d_{max}	mm	maximum diameter of wire
d_{wire}	mm	wire diameter after coiling
d_R	mm	diameter of loading pins
L_B	mm	body length in axis direction (excluding legs) when unloaded
l	mm	length of leg (without considering working effect) see Annex C
l_1, l_2, \dots	mm	length of leg segments (without considering working effect)
l_w	mm	effective working length of leg
$l_{w,1}, l_{w,2}, \dots$	mm	effective working length of legs

Table 1 (continued)

Symbols	Units	Designations
M	N·mm	spring torque or moment
M_n	N·mm	spring torque for the maximum test torsional angle and related leg length
M_1, M_2, \dots	N·mm	spring torques for the specified spring loads
n	-	number of coils
p	mm	spring pitch
$R_M = \frac{\Delta M}{\Delta \alpha} = \frac{M_2 - M_1}{\alpha_2 - \alpha_1}$	N·mm/rad, N·mm/degree	angular spring rate (see Annex A)
r	mm	bending radius
r_1, r_2, \dots	mm	inner bend radius on legs
r_w	mm	effective working radius
$r_{w,1}, r_{w,2}, \dots$	mm	effective working radius of legs
u	mm	distance between the coils
α_h	rad, degree	angular deflection of spring (stroke) between two positions α_1, α_2
α_n	rad, degree	maximum permissible test torsional angle
γ_0	rad, degree	the position angle between two legs when unloaded
$\alpha_1, \alpha_2, \dots$	rad, degree	torsional angles for the specified spring torques, M_1, M_2, \dots
ε_0	degree	relative end fixture angle for unloaded spring
$\varepsilon_1, \varepsilon_2, \dots$	degree	relative end fixture angle corresponding to $\alpha_1, \alpha_2, \dots$
$\varphi_1, \varphi_2, \dots$	rad, degree	angle of bend on legs

The symbols for unloaded torsion spring is shown in Figure 1. The torsion spring with tangential ends is shown in Figure 2. The torsion spring when loaded is shown in Figure 3.

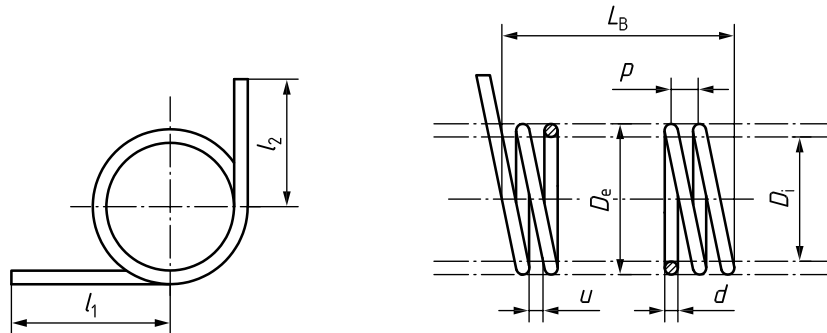

Figure 1 — Symbols for unloaded torsion spring

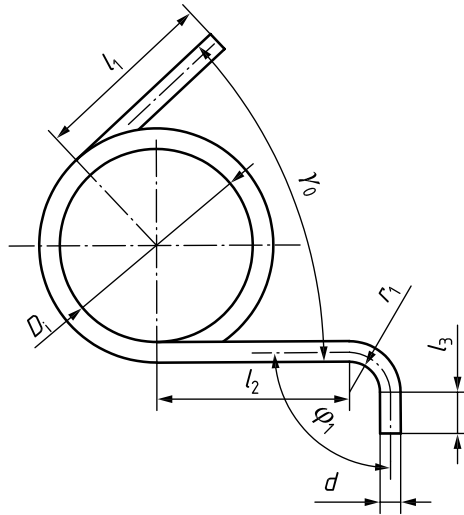

Figure 2 — Torsion spring with tangential ends

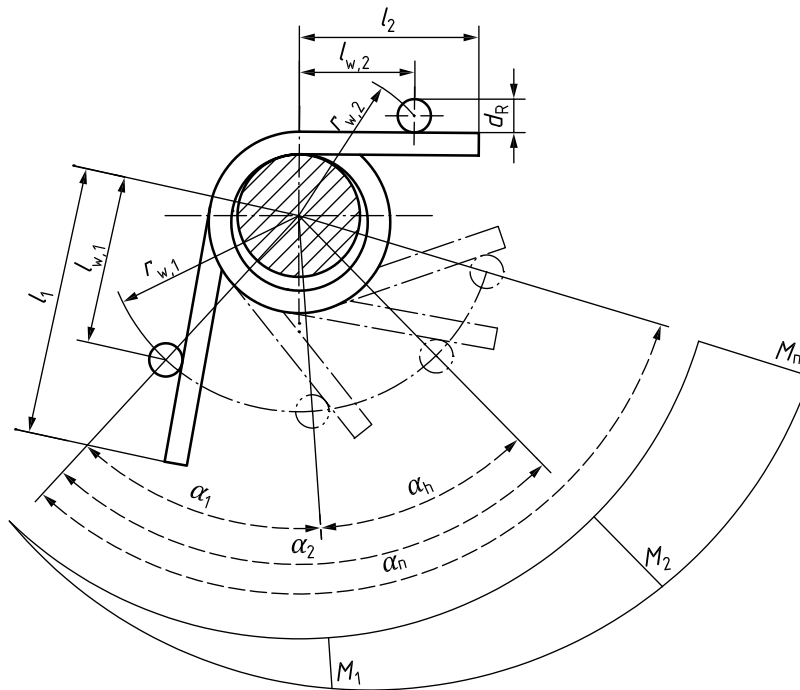

Figure 3 — Torsion spring when loaded

4 Environmental conditions

The spatial distribution and equipment of the facility shall permit a reliable implementation of the measurement and test.

Measurements and tests should be carried out at ambient temperature in a normal workshop environment.

Special tests (e.g. in air-conditioned rooms or other special environments) shall be agreed upon between the manufacturer and the customer.

Measuring and testing equipment should be subject to regular inspection.

5 Qualifications of the person(s) performing the work

The measurements and tests shall be carried out by a person who has been instructed/trained in the use of the measuring and testing equipment, as well as regarding methods and test requirements.

The qualifications or additional knowledge and skills shall be documented in appropriate qualification or training documents, depending on the requirements.

6 Geometries of guiding and supporting devices

If necessary, geometries of guiding and supporting devices (mandrels, guide sleeves, ring groove, etc.) shall be agreed upon between the manufacturer and the customer to include special cases such as snapping end coils, buckling, bulging. The alignment of guiding and supporting devices is aimed to improve the reproducibility of the measurements.

7 Measuring and testing equipment

Suitable measuring equipment shall be selected (standards such as ISO 3611 for micrometers and ISO 13385-1 for callipers can be used to ensure suitability).

8 Measurement and test parameter for technical cold formed cylindrical torsion springs

8.1 Body length (L_B)

8.1.1 General

The body length L_B is a measurement and test parameter.

8.1.2 Type of characteristic

The body length L_B is the body length in the axis direction (excluding legs) when no load is applied (see [Figure 4](#)); other case should be agreed upon between the manufacturer and the customer.

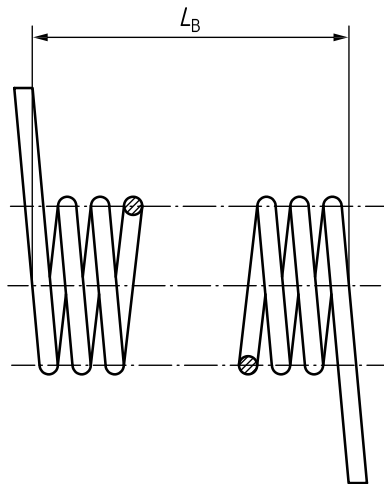

Figure 4 — Body length (L_B) of the unloaded torsion spring for open-coiled springs

8.1.3 Measuring and/or testing equipment

The following measuring equipment can be used:

- micrometer gauge;

- height gauge;
- calliper;
- dial gauge/indicating calliper;
- electronic measuring sensor;
- optical measuring instruments/measurement microscope/camera systems/projector.

In the case of attributive testing, the following testing equipment can be used:

- attributive gauges (“GO/NO GO” gauges).

8.1.4 Conditions of measurement and testing

The body length L_B shall be evaluated at ambient temperature as delivered.

8.1.5 Method of measurement and testing

The measurement can be carried out without contact using optical procedures, capacitive or electrically by contact (with minimal force) or by contact with the measuring surfaces (within tolerance/out of the tolerance/test gauges) (see [Figure 5](#)).

When there is a spring self-weight effect, the measurement of body length should be agreed upon between the manufacturer and the customer.

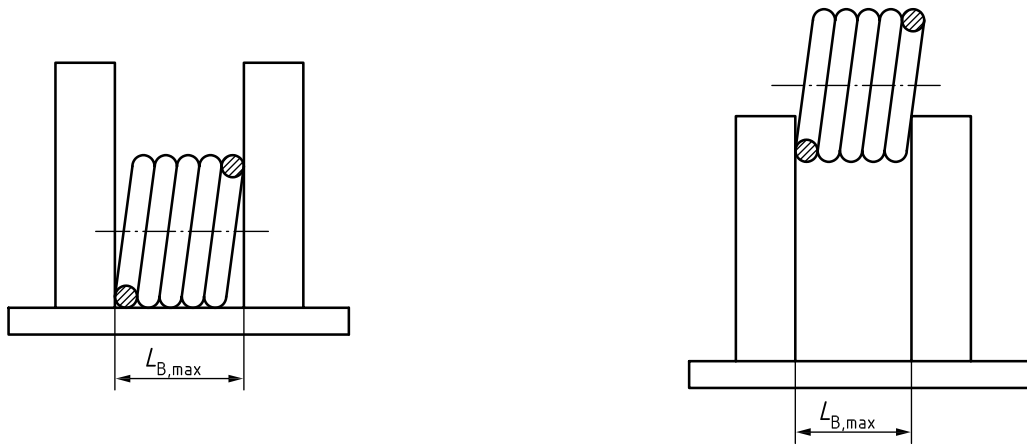

a) Tolerance upper limit check with gauge ($L_B \leq L_{B,max}$) (GO/within tolerance)

b) Tolerance upper limit check with gauge ($L_B > L_{B,max}$) (NO GO/out of tolerance)

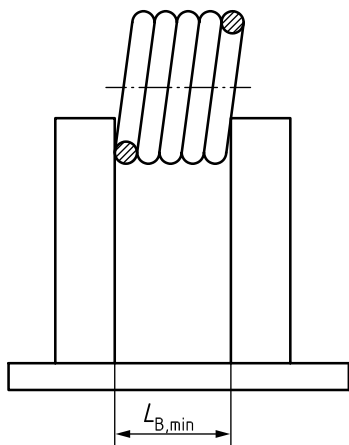

c) Tolerance lower limit check with gauge ($L_B < L_{B,min}$) (NO GO/within tolerance)

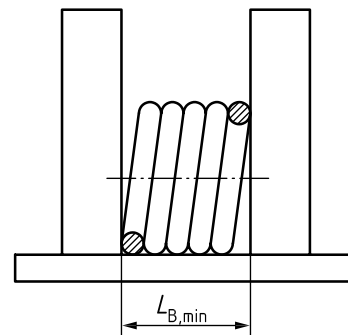

d) Tolerance lower limit check with gauge ($L_B \geq L_{B,min}$) (GO/out of tolerance)

Figure 5 — Method of testing of the body length (L_B) with gauges (examples)

8.1.6 Test location on the product

The test direction is in the axial direction to the finished spring. The measuring position is the distance between the tangent points of the two torsion legs and parallel to the axis of the spring body.

When measuring equipment is used that induces a measuring force then the applied force should not significantly deflect and/or compress the spring.

When optical measuring equipment (camera systems) is used, the measurement axis is perpendicular to the spring axis.

8.2 Outside diameter (D_e)

8.2.1 General

The outside diameter D_e is a measurement and test parameter.

8.2.2 Type of characteristic

The outside diameter D_e is the value of the outside diameter through the whole spring body (see [Figure 6](#)). If legs are bent in the outside part of the spring body or the legs overlap the outside diameter, the legs have to be ignored.

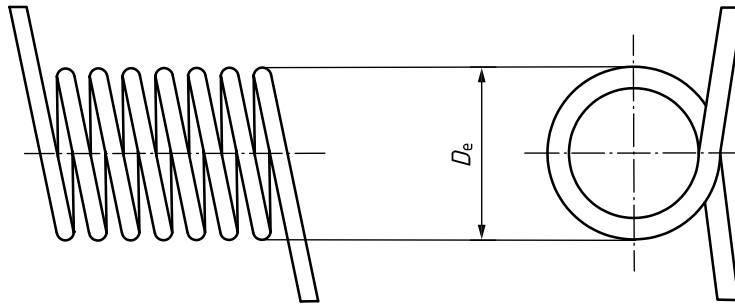

Figure 6 — Outside diameter (D_e)

8.2.3 Measurement and/or testing equipment

The following measuring equipment can be used:

- micrometer gauge;
- calliper;
- dial gauge.

Alternatively, optical measuring equipment can be used.

In the case of attributive testing, the following testing equipment can be used:

- test sleeve;
- special gauge (part-based);
- snap gauge.

The shape and dimension of all testing equipment shall be agreed upon between the manufacturer and the customer.

8.2.4 Conditions of measurement and testing

The outside diameter D_e shall be evaluated at ambient temperature as delivered.

8.2.5 Method of measurement and testing

a) Variable measurement (e.g. calliper) (see [Figure 7](#))

The measurement is performed at several locations on the product, at least at the beginning, in the centre and at the end of the spring. In the case of no interference with the legs, the measurements at the end are performed in two perpendicular directions of the spring. Each measured value shall be within the tolerance. The maximum measured value shall be documented.

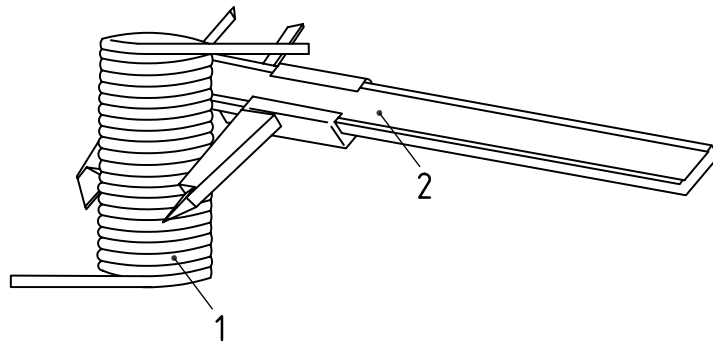

Key

- 1 spring
- 2 calliper

Figure 7 — Method of measurement of the outside diameter D_e with calliper (example)

b) Variable measurement (e.g. dial gauge) (see [Figure 8](#))

The measurements are to be carried out (0° - 180° , 90° - 270°). The measured values shall be within the tolerance. The maximum measured value shall be documented.

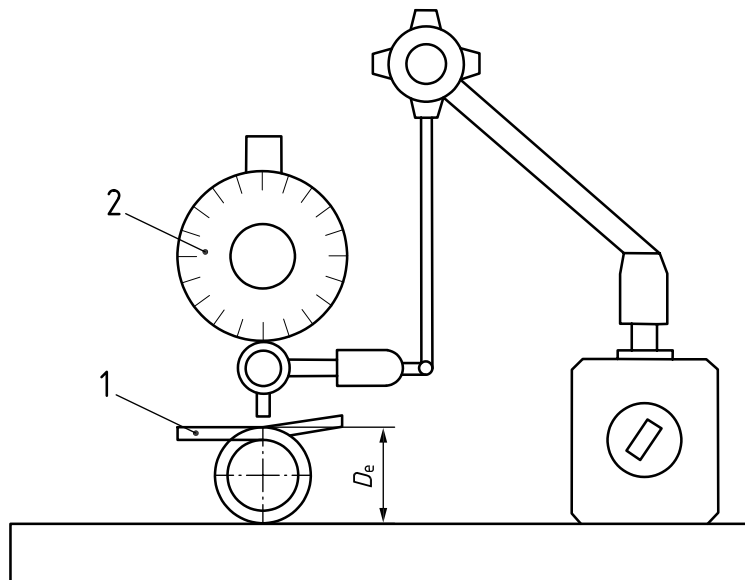

Key

- 1 spring
- 2 dial gauge

Figure 8 — Method of measurement of the outside diameter D_e with dial gauge (example)

c) **Attributive testing (within tolerance/out of the tolerance/test gauges)** (see [Figure 9](#))

The spring shall fall through the gauge due to its own weight at $D_{e,max}$.

The spring shall not fall through the gauge due to its own weight at $D_{e,min}$.

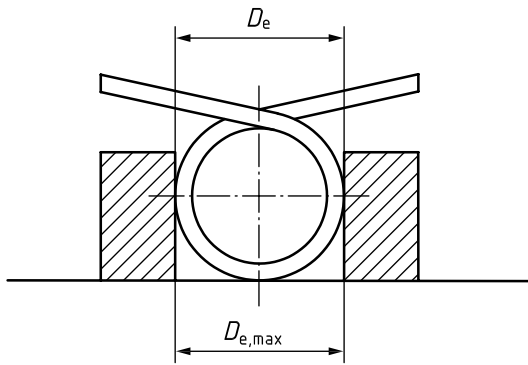

a) Tolerance upper limit check with gauge
($D_e \leq D_{e,max}$) (GO/within tolerance)

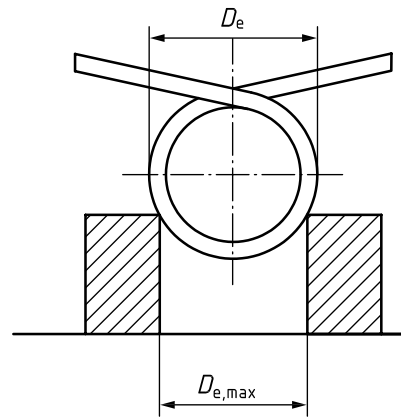

b) Tolerance upper limit check with gauge
($D_e > D_{e,max}$) (NO GO/out of tolerance)

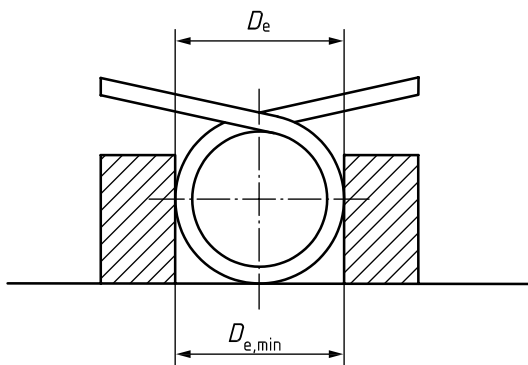

c) Tolerance lower limit check with gauge
($D_e < D_{e,min}$) (GO/out of tolerance)

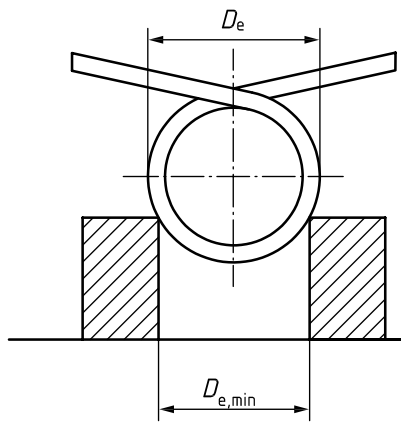

d) Tolerance lower limit check with gauge
($D_e \geq D_{e,min}$) (NO GO/within tolerance)

Figure 9 — Method of testing of the outside diameter D_e with gauges (examples)

8.2.6 Test location on the product

a) Variable measurement

The measurement is performed at several locations on the product, at least at the beginning, in the centre and at the end of the spring with no load applied.

b) Attributive testing

The test is carried out over the entire length of the spring. The test sleeve length shall correspond to at least the clearance of 2 coils.

For the purpose of testing geometrical deviations (enveloping circle, curvature), a test sleeve with the length and diameter for cylindrical springs can be agreed upon between the manufacturer and the customer.

8.3 Inside diameter (D_i)

8.3.1 General

The inside diameter D_i is a measurement and test parameter.

8.3.2 Type of characteristic

The inside diameter D_i is the minimum value of the inside diameter through the whole spring body (see [Figure 10](#)). If legs are bent in the interior part of the spring body or the legs overlap the inside diameter, the legs have to be ignored.

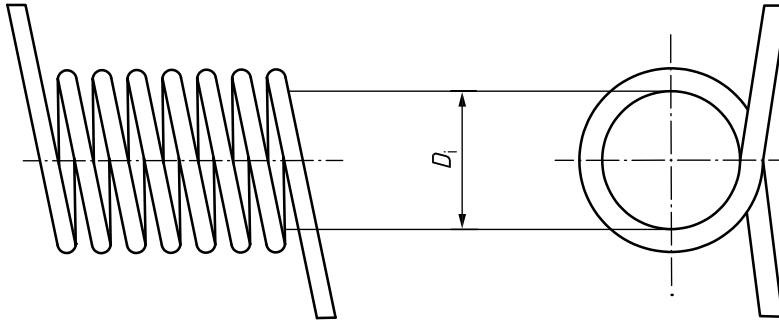

Figure 10 — Inside diameter (D_i)

8.3.3 Measurement and/or testing equipment

The following measuring equipment can be used:

- calliper.

Alternatively, a micrometer screw or optical measuring equipment can be used.

In the case of attributive testing, the following testing equipment can be used:

- test pin;
- special gauge (part-based), e.g. GO/NO GO gauge.

8.3.4 Conditions of measurement and testing

The inside diameter D_i shall be evaluated at ambient temperature as delivered.

8.3.5 Method of measurement and testing

- a) Variable measurement (e.g. calliper) (see [Figure 11](#))

If the length of the calliper jaws is equal to or greater than the body length, take only two measurements in perpendicular directions.

If the length of the calliper jaws is less than the body length, take only two measurements in perpendicular directions at each end of the body, and measure the inside diameter at the centre of the body indirectly by measuring the outside diameter and subtracting two wire diameters d_{wire} .

The measurement method of inside diameter can be agreed upon between the manufacturer and the customer. The measured values shall be within the tolerance. The minimum measured value shall be documented.

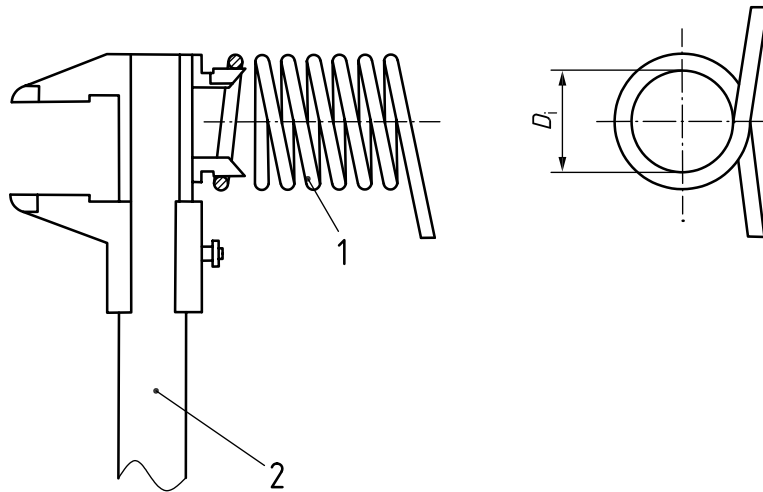

Key

- 1 spring
- 2 calliper

Figure 11 — Method of measurement of the inside diameter (D_i) with calliper (example)

b) **Attributive testing (within tolerance/out of the tolerance/test pin)** (see [Figure 12](#))

The spring shall not fall over the test pin due to its own weight at $D_{i,max}$ ([Figure 12 a](#)).

The spring shall fall over the test pin due to its own weight at $D_{i,min}$ ([Figure 12 c](#)).

Both above-mentioned criteria shall be met, regardless of which side of the spring is attached to the test pin.

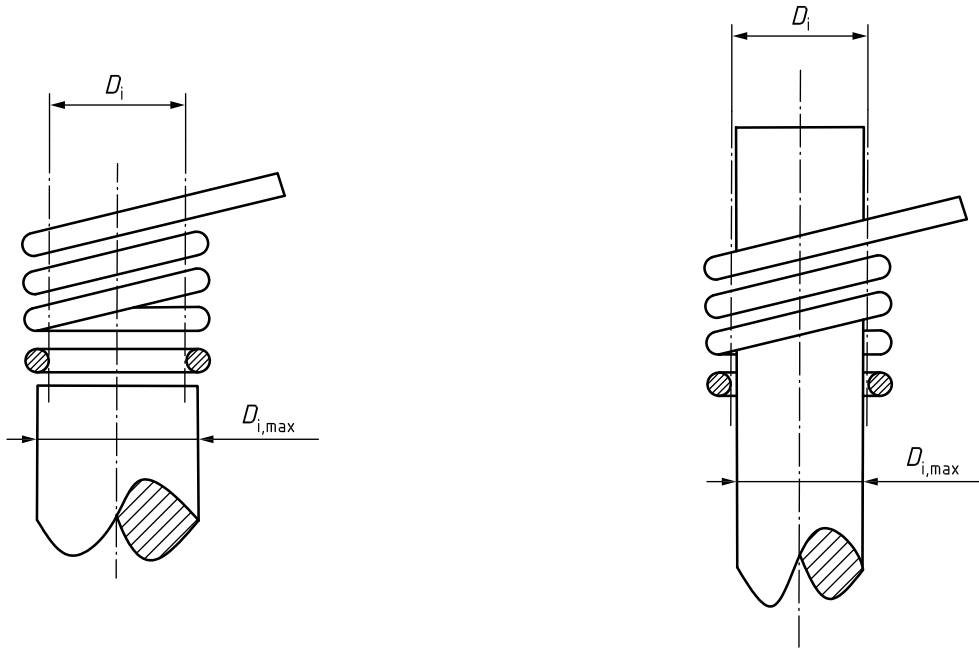

a) Tolerance upper limit check with test pin
 $(D_i \leq D_{i,max})$ (NO GO/within tolerance)

b) Tolerance upper limit check with test pin
 $(D_i > D_{i,max})$ (GO/out of tolerance)

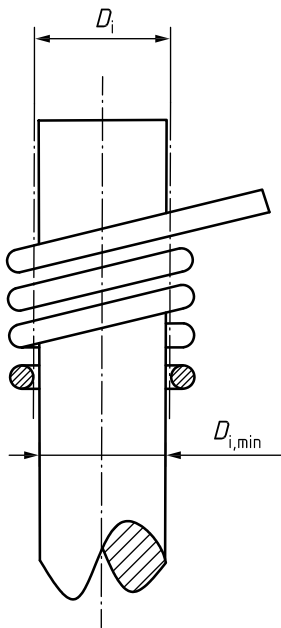

c) Tolerance lower limit check with test pin
 $(D_i \geq D_{i,min})$ (GO/within tolerance)

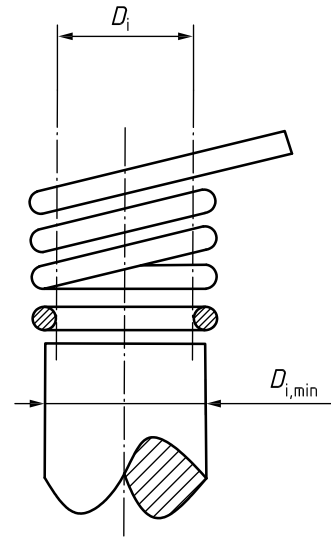

d) Tolerance lower limit check with test pin
 $(D_i < D_{i,min})$ (NO GO/out of tolerance)

Figure 12 — Method of testing the inside diameter (D_i) with test pin (examples)

8.3.6 Test location on the product

- a) Variable measurement

Where the spring has legs, the measurement is carried out on the outside diameter and the value can be calculated by the following formula

$$D_i = D_e - 2 \times d_{\text{wire}}$$

Where d_{wire} is the wire diameter after coiling.

b) **Attributive testing**

The test is carried out over the entire length of the spring (L_B).

For the purpose of testing geometrical deviations (enveloping circle, curvature), a test gauge can be agreed upon between the manufacturer and the customer.

8.4 Spring leg length (l)

8.4.1 General

The spring leg length l is a measurement and test parameter.

8.4.2 Type of characteristic

The spring leg length l is the length of each leg segment when there is no load. Torsion springs can have legs with more than one leg segment (see [Figure 13](#)).

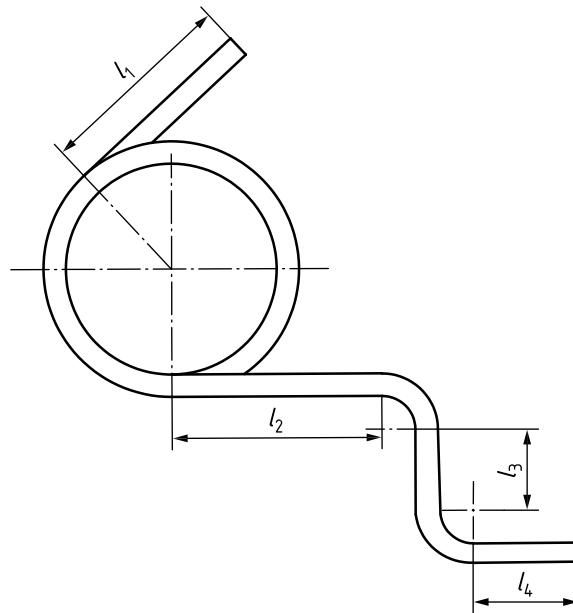

Figure 13 — Spring leg length (l)

8.4.3 Measurement and/or testing equipment

The following measuring equipment can be used:

- calliper;
- electronic measuring sensor;
- optical measuring instruments/measurement microscope/camera systems/projector.

In the case of attributive testing, the following testing equipment can be used:

- attributive gauges (“GO/NO GO” gauges).

8.4.4 Conditions of measurement and testing

The spring leg length l shall be evaluated at ambient temperature as delivered.

8.4.5 Method of measurement and testing

In the case of tangential legs (see [Annex B](#), Figure B.1 a), the measurement is carried out indirectly using a calliper remembering to subtract half of the body outside diameter from the measurement.

The leg length l is the indirect measurement value. The measurement method is to measure the distance from the end of torsion leg to the outside of spring body minus half of the measured value of outer diameter of spring. According to the formula $l_1 = A - \frac{D_e}{2}$, $l_2 = B - \frac{D_e}{2}$, the measurement method is shown in [Figure 14](#).

In the case of optical measurement, the axis of the wound body is mounted perpendicular to the measuring plane by means of a mandrel or fixture. If the spring body is parallel to the measuring plane, it shall be fixed in such a way that the legs to be measured are also parallel to the measuring plane.

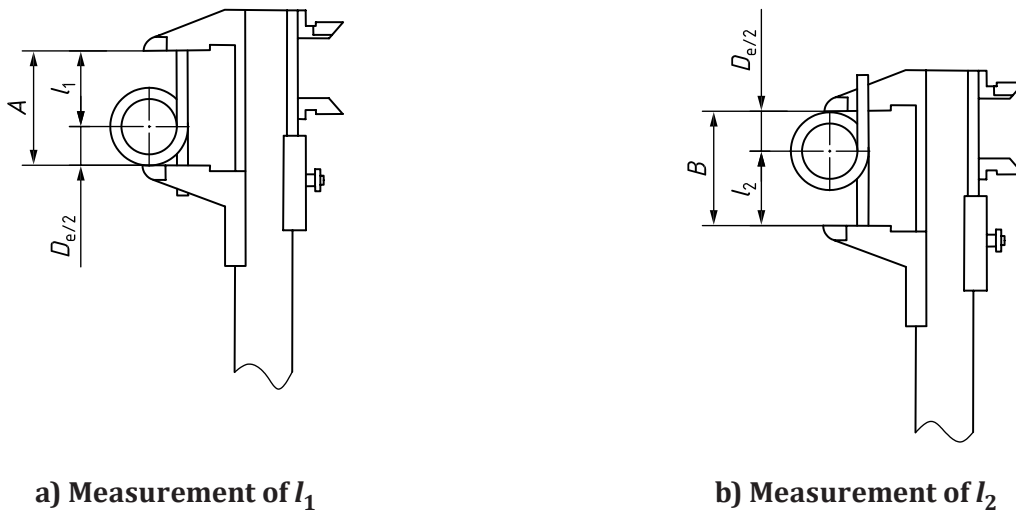

Figure 14 — Method of measurement of the spring leg length (l) with calliper (examples)

8.4.6 Test location on the product

Measurement takes place from leg end l_1/l_2 to the opposite facing spring body in one plane.

The test direction is in the axial direction to the spring legs. When measuring equipment is used that induces a measuring force, then the applied force should not deflect the spring.

When optical measuring equipment (camera systems) is used, the measurement axis is perpendicular to the spring leg.

8.5 Number of coils (n) and coil direction

8.5.1 General

The number of coils n and the coil direction are test parameters. All coils are active in the torsion spring.

8.5.2 Type of characteristic

Number of coils n is the number of wire rotations/coils around the spring axis, see [Figure 15](#).

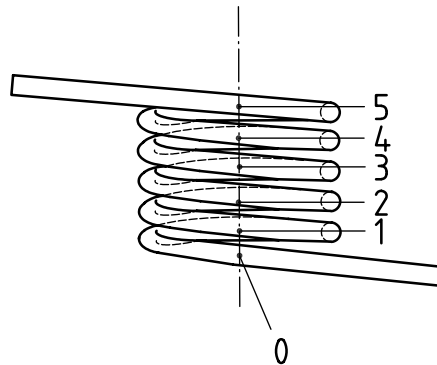

Key

- 1 coil number 1
- 2 coil number 2
- 3 coil number 3
- 4 coil number 4
- 5 coil number 5

Figure 15 — Number of coils (n)

8.5.3 Measurement and/or testing equipment

The following measuring equipment can be used:

- visual inspection;
- test template;
- optical test;
- projector;
- measuring microscope;
- camera system.

8.5.4 Conditions of measurement and testing

The number of coils n shall be evaluated at ambient temperature as delivered.

8.5.5 Method of measurement and testing

All tests are carried out on the unloaded spring.

The wire coil rotations shall be counted from one end of the wire (spring body end) to the other.

The coil direction can be clockwise (right-handed) or counterclockwise (left-handed) (see [Figure 16](#)).

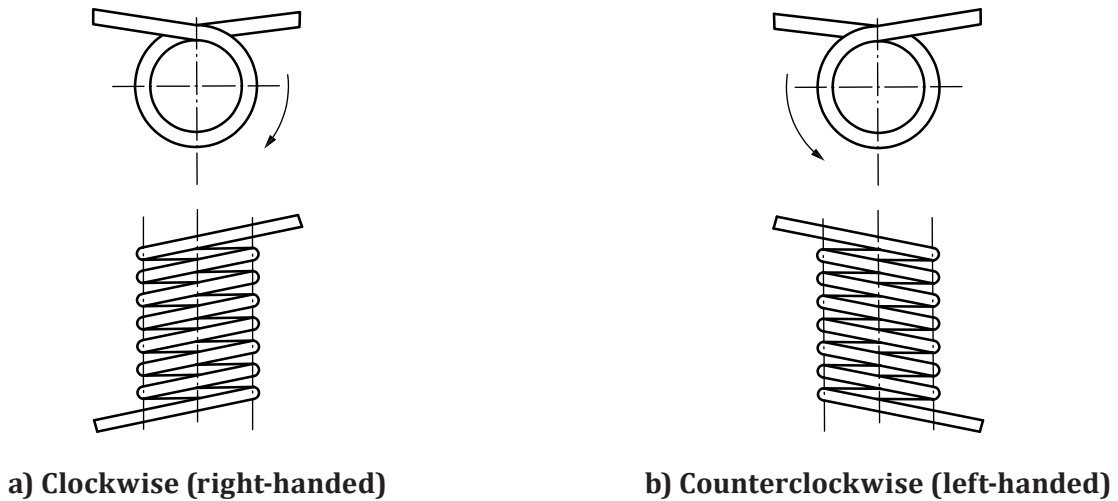

Figure 16 — Coil direction

8.5.6 Test location on the product

The entire spring body shall be considered.

8.6 Bending radius on legs (r)

8.6.1 General

The bending radius on legs r is a measurement and test parameter.

8.6.2 Type of characteristic

The bending radius on legs r applies to either the bending (inside) radius of bent legs or the bending (inside) radius of axially raised legs at the transition to the last turn, see [Figure 17](#).

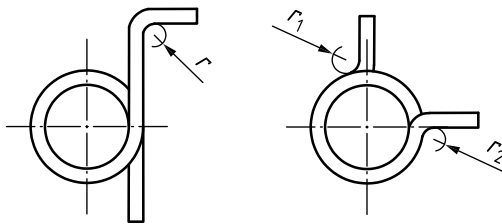

Figure 17 — Bending radius on legs (r)

8.6.3 Measurement and/or testing equipment

The following measuring equipment can be used:

- visual inspection (e.g. radius gauge);
- optical test;
- radius gauge;
- optical measuring instruments/measurement microscope/camera systems;
- template.

8.6.4 Conditions of measurement and testing

The bending radius on legs r shall be evaluated at ambient temperature as delivered.

8.6.5 Method of measurement and testing

All tests are carried out on the unloaded spring. [Figure 18](#) shows the schematic diagram of measuring with radius gauge.

In the case of optical measurements, the spring element shall be aligned perpendicular to the measuring plane using a mandrel or suitable fixture. If the spring body is parallel to the measuring plane, it shall be fixed in such a way that the legs to be measured are also parallel to the measuring plane.

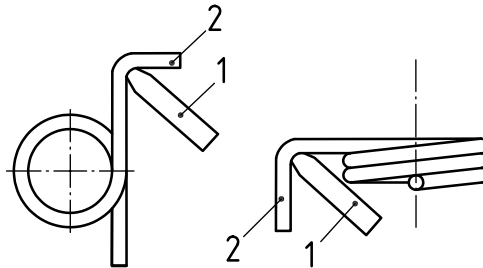

Key

- 1 radius gauge
- 2 torsion spring

Figure 18 — Measuring the bending radius (r) of torsional leg with radius gauge (example)

8.6.6 Test location on the product

When measuring equipment is used that induces a measuring force, then the applied force should not deflect the spring.

When optical measuring equipment (camera systems) is used, the measurement axis is perpendicular to the spring bend angle.

8.7 Angle of bend on legs (φ)

8.7.1 General

The angle of bend on legs φ are measurement and test parameter.

8.7.2 Type of characteristic

The angle of bend on legs φ is the angle between two adjacent leg segments, see [Figure 19](#).

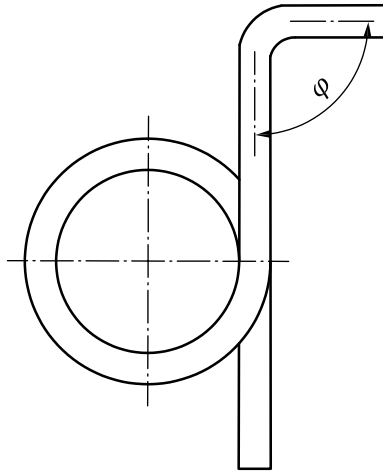

Figure 19 — The angle of bend on legs (φ)

8.7.3 Measurement and/or testing equipment

The following measuring equipment can be used:

- template;
- projector;
- protractor;
- angle gauge;
- optical measurement system;
- measuring microscope.

8.7.4 Conditions of measurement and testing

The angle of bend on legs φ shall be evaluated at ambient temperature as delivered.

8.7.5 Method of measurement and testing

All tests are carried out on the unloaded spring.

The measurement shall be performed without contact (optical) or with minimal force application without a deflection of the angle (manual check, see [Figure 20](#)).

For optical measurement, the spring body shall be aligned perpendicular to the measuring plane by means of a mandrel or suitable fixture. If the coiled body is parallel to the measuring plane, it shall be fixed in such a way that the legs to be measured are also parallel to the measuring plane.

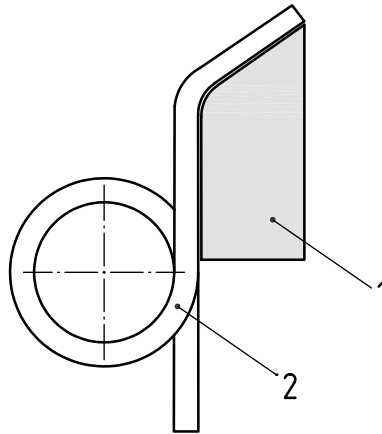

Key

- 1 template
- 2 torsion spring

Figure 20 — Measuring the angle of bend on legs (φ) of torsional leg with template (example)

8.7.6 Test location on the product

The measurement should be performed perpendicular to the spring legs.

8.8 Spring pitch (p)/distance between the coils (u)

8.8.1 General

The spring pitch p and distance between the coils u are measurement parameters.

The (functional) spring characteristic with the corresponding tolerances should be defined, rather than specifying the spring pitch p or distance between the coils u .

8.8.2 Type of characteristic

The distance between two consecutive coils in the direction of the spring axis is u .

The spring pitch p can be calculated with the distance between coils u and the diameter of wire d_{wire} :

$$p = d_{\text{wire}} + u$$

[Figure 21](#) illustrates the difference between distance between coils u and spring pitch p .

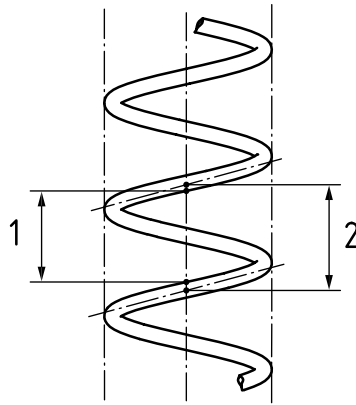
**Key**

- 1 distance between the coils (u)
- 2 spring pitch (p)

Figure 21 — Difference between spring pitch and distance between the coils

8.8.3 Measurement and/or testing equipment

The following measuring equipment can be used:

- calliper (with the corresponding dimension);
- optical test (identity check);
- sample rod;
- feeler gauge.

8.8.4 Conditions of measurement and testing

The spring pitch p and distance between the coils u shall be evaluated at ambient temperature as delivered.

8.8.5 Method of measurement and testing

The measurement can be performed without contact (optical) or with minimal force application (manual check).

The measurement should be performed perpendicular to the spring axis.

8.8.6 Test location on the product

The test location is to be defined between the manufacturer and the customer.

The measuring point should be precisely defined, since there is partly different distance between the coils in the spring.

8.9 Spring torque (M)**8.9.1 General**

The spring torque M is a measurement parameter.

8.9.2 Type of characteristic

The spring torque M is a torsional load applied to the legs of the torsion spring with the loading pins in closing direction (see [Figure 3](#)).

The spring torques M_1, M_2, \dots are the assigned spring torques to the rotation angles of the loaded spring $\alpha_1, \alpha_2, \dots$.

8.9.3 Measurement equipment

The following measuring equipment can be used:

- spring torque tester

NOTE In most cases the torque is the required measurement parameter for testing torsion springs. In very rare cases, the force is requested when testing the springs. If the spring force is required, the geometries of guiding and supporting devices (e.g. test pins, guide bushings, ring groove) may be agreed upon between the manufacturer and the customer.

8.9.4 Conditions of measurement

Before measuring the spring torque, the actual leg position is recorded.

The spring torque shall be evaluated at ambient temperature as delivered. Unless otherwise agreed with the customer, the spring should not be touched during testing and no additional lubrication should be used.

The spring shall be supported on a mandrel for its whole length and loaded using pins. The diameter of a torsion spring reduces as the spring is wound up, and the mandrel diameter should be smaller than the minimum spring inside diameter at the maximum deflection.

8.9.5 Method of measurement

Unless otherwise specified, the torque measurement procedure should be as follows (see [Figure 22](#)):

- 1) Insert spring into testing device.
- 2) Rotate testing pins in direction of loading to position ε_0 (where torque can start to be measured by the test device).
- 3) Rotate testing pins to ε_n and then return to ε_0 .
- 4) Rotate testing pins to $\varepsilon_1, \varepsilon_2 \dots$ and record torques at each position required.

NOTE $\varepsilon_0, \varepsilon_1, \varepsilon_2, \dots$ corresponds to $\gamma_0, \alpha_1, \alpha_2, \dots$

If other conditions are requested by the customer or the manufacturer, they shall be agreed upon between the manufacturer and the customer (e.g. measuring by increasing without presetting or decreasing angles/torques).

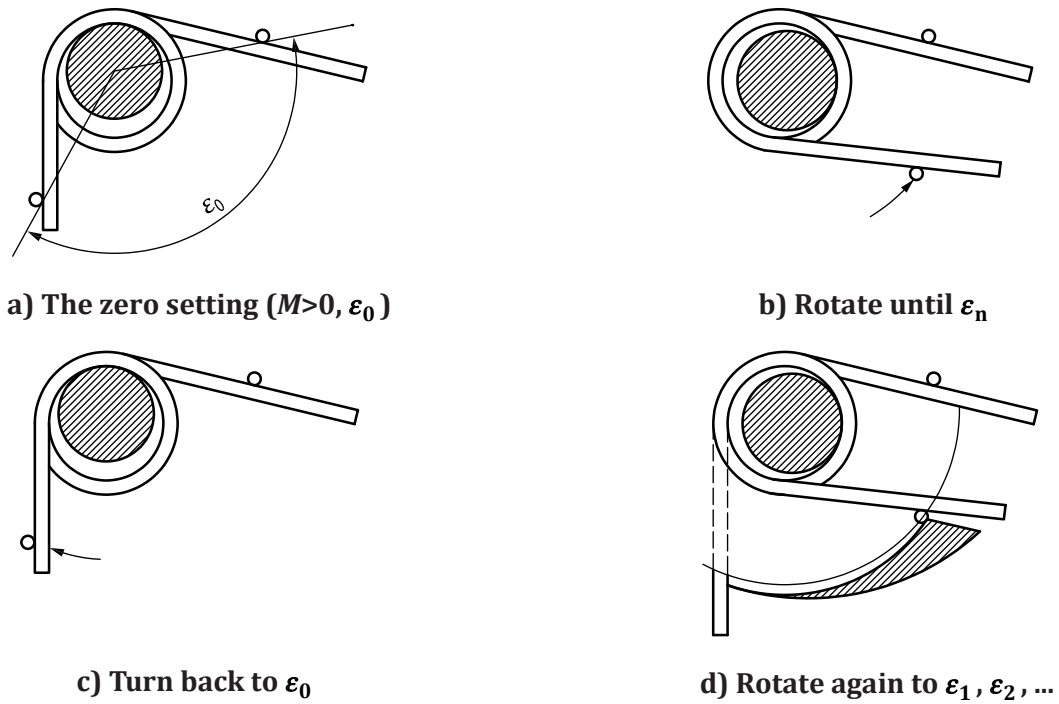

Figure 22 — Torque test schematic diagram

8.9.6 Test location on the product

Unless otherwise specified in the drawing, measuring conditions should be agreed upon between the manufacturer and the customer. The entire spring body shall be adequately supported by the mandrel in the tester. The spring torque is measured at the points of the moment leg contact.

8.10 Free angle (γ_0)

8.10.1 General

The free angle γ_0 is a measurement and test parameter.

8.10.2 Type of characteristic

The free angle γ_0 is the position angle between two legs when unloaded, see [Figure 23](#).

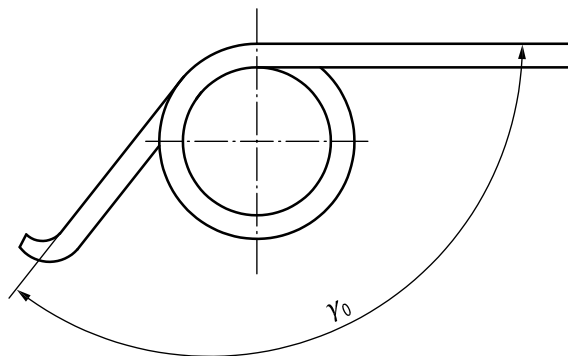

Figure 23 — The free angle (γ_0)

8.10.3 Measurement and/or testing equipment

The following measuring equipment can be used:

- optical measuring device;
- projector;
- measuring microscope;
- camera system (without measuring force);
- protractor.

In the case of attributive testing, the following measuring equipment should be used:

- gauge.

8.10.4 Conditions of measurement and testing

The free angle γ_0 shall be evaluated at ambient temperature as delivered.

8.10.5 Method of measurement and testing

The measurements and tests are carried out on the spring without load. The spring is aligned on a fixture on the diameter, perpendicular to the spring axis. An alignment is made from the first to the second leg. This test can also be carried out with a protractor, using the light gap method. It is also possible to check the leg position with a gauge.

8.10.6 Test location on the product

The measurement should be performed perpendicular to the spring axis.

8.11 Shear-off burr

8.11.1 General

The shear-off burr is a test parameter.

8.11.2 Type of characteristic

The inspected property is the shear-off burr resulting from cutting off at both ends of the spring, see [Figure 24](#).

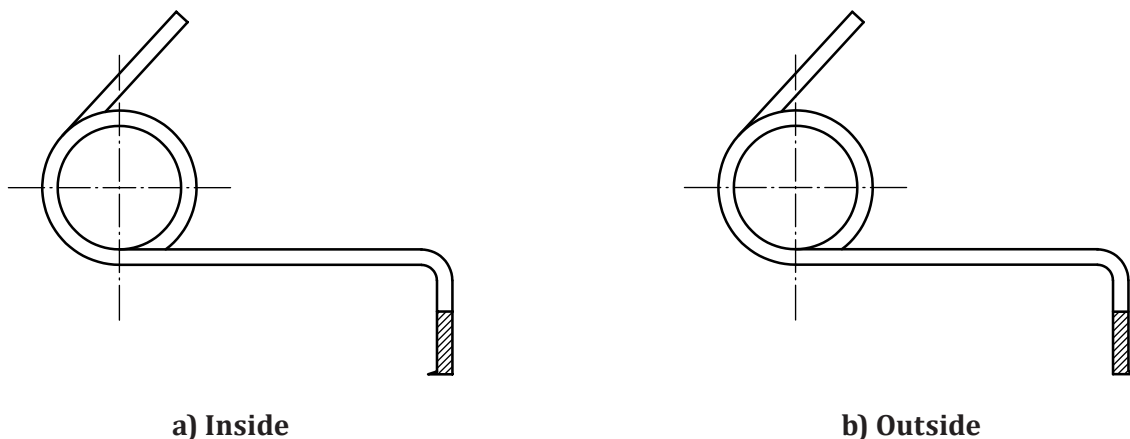

Figure 24 — The shear-off burr

8.11.3 Test equipment

Evaluation is carried out by test. This test is the assessment of the sharp edge (subjective evaluation).

The following testing equipment can be used:

- test pin and test sleeve;
- calliper;
- gauge;
- magnifying glass;
- projector;
- stereoscopic microscope;
- camera.

Unless otherwise agreed between customer and manufacturer, assessment is done with naked eye.

8.11.4 Conditions of testing

The shear-off burr shall be evaluated at ambient temperature as delivered.

8.11.5 Method of testing

One of the following test methods shall be applied:

- visual inspection;
- magnifying glass test;
- projector test;
- stereoscopic microscope test;
- camera test.

The shear-off burr should be taken into account when testing with a mandrel or sleeve. The shear-off burr shall not exceed/undercut the tolerances of the inside and outside diameter.

8.11.6 Test location on the product

Tests are carried out at the points where the wire is cut off/sheared.

Annex A (informative)

Calculation of spring rate R_M

A.1 General

The spring rate R_M [$\text{N} \cdot \text{mm}/\text{rad}$, $\text{N} \cdot \text{mm}/\text{degree}$] is a parameter and is determined by calculation.

To calculate the spring rate, take two torque measurements at two agreed positions within the range of 30 % to 70 % of the safe deflection.

A.2 Type of characteristic

$$R_M = \frac{\Delta M}{\Delta \alpha} = \frac{M_2 - M_1}{\alpha_2 - \alpha_1}$$

ΔM is the increase in torque corresponding to an increase in angle $\Delta \alpha$.

The spring rate calculation is between two points only, and does not define the whole travel of the spring. Furthermore, the rate of the torsion spring will not be constant, especially near the delivery position and the maximum permissible end position.

Annex B
(informative)

Type of legs

Due to the wide variety of legs, not all types are represented here. Some examples are shown in [Figure B.1](#).

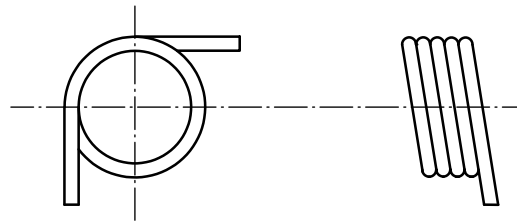

a) Tangential legs

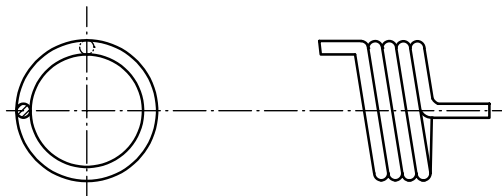

b) Axial legs

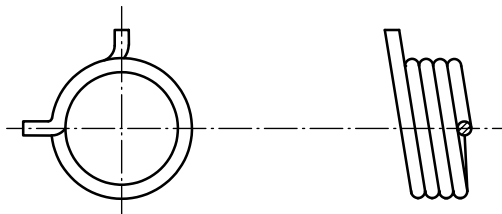

c) Radial external legs

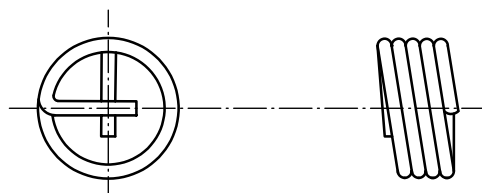

d) Radial internal legs

Figure B.1 — Type of legs

Annex C (informative)

Measurement of the length of leg l

Each torsion leg can be idealized as a series of straight leg segments (l_1, l_2, \dots) and bend segments, with each bend segment having a measurable inner bending radius (r_1, r_2, \dots) and angle of bend (ϕ_1, ϕ_2, \dots) (see [Figure C.1](#)).

When measuring the length of leg l , it is permissible to use other characteristics of the spring such as the wire diameter after coiling (d_{wire}), outside diameter (D_e) and bending radius (r_1, r_2, \dots), as long as the characteristics are used.

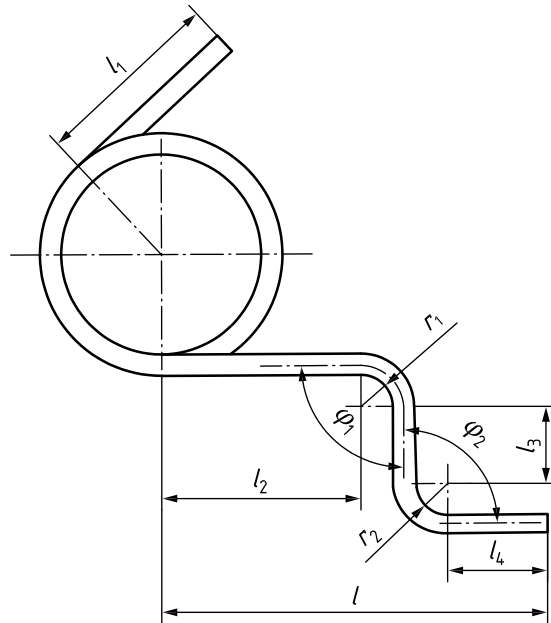

Figure C.1 — Measurement of the length of leg l

Annex D (informative)

Offset of leg *c*

The offset of leg *c* is a measurement parameter. If one or both legs are not tangential because of a bend, the distance between the outer part of the leg to the outside diameter of the spring body is the offset of leg (see [Figure D.1](#)).

The following can be used as measuring equipment: calliper gauge (for tangential legs and depending on the dimensioning or customer agreement), optical measuring device/projector/measuring microscope/camera system. Test equipment should be agreed between the manufacturer and the customer.

For measurement, the coiled body is to be aligned perpendicular to the measuring plane by means of a mandrel or suitable fixings (prism or similar). The leg to be measured is aligned with the measuring plane, the measuring device is zeroed and the length is moved to the spring body. A measurement with a calliper gauge is also possible with a proper adapter.

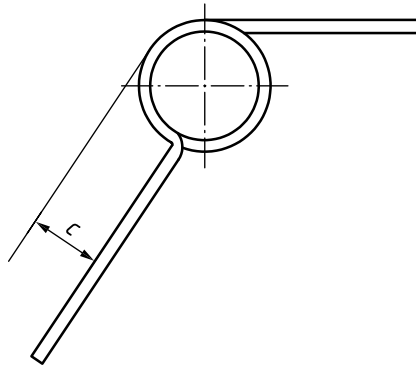

Figure D.1 — The offset of leg *c*

Bibliography

- [1] ISO 3611, *Geometrical product specifications (GPS) — Dimensional measuring equipment: Micrometers for external measurements — Design and metrological characteristics*
- [2] ISO 13385-1, *Geometrical product specifications (GPS) — Dimensional measuring equipment — Part 1: Design and metrological characteristics of callipers*
- [3] ISO 16249, *Springs — Symbols*
- [4] ISO 26909, *Springs — Vocabulary*



ICS 21.160

Price based on 30 pages

© ISO 2024
All rights reserved

iso.org