

पीयूसी उपकरण (गैस विश्लेषक और धुआं मीटर)
- विशिष्टता और परीक्षण विधियां

PUC EQUIPMENT (GAS ANALYZER AND
SMOKE METER) – SPECIFICATION AND
TEST METHODS

ICS: 13.040

© BIS 2024



भारतीय मानक ब्यूरो
BUREAU OF INDIAN STANDARDS
मानक भवन, 9 बहादुर शाह ज़फर मार्ग, नई दिल्ली 110002
MANAK BHAVAN, 9 BAHADUR SHAH ZAFAR MARG
NEW DELHI 110002
www.bis.gov.in www.standardsbis.in

JULY 2024

Price Group 10

In Service Vehicle Inspection, Certification and Garage Equipment Sectional Committee, TED
31

FOREWORD

This Indian Standard was adopted by the Bureau of Indian Standards, after the draft finalized by the In-Service Vehicle Inspection, Certification and Garage Equipment Sectional Committee had been approved by the Transport Engineering Division Council (TEDC).

Automobile vehicle running on diesel and petrol do exhaust certain hydrocarbon gases to the atmosphere. These hydrocarbons become involved in photochemical reactions in the atmosphere, which cause harm to human, plant and animal life. It becomes imperative to measure these hydrocarbons and put restriction on the exhaust limit. For measurement of these emission Smoke meter and 4 Gas analyzer are used for in-use vehicles.

In formulation of this standard, considerable assistance has been taken from AIS-137 (Part 8). Administrative procedure for Conformity of Production is given in **Annex- A**.

The composition of the Committee responsible for formulating this standard is given in **Annex- B**.

For the purpose of deciding whether a particular requirement of this standard is complied with, the final value, observed or calculated, expressing the result of test or analysis, shall be rounded off in accordance with IS 2:2022 'Rules for rounding off numerical values (*second revision*)'. The number of significant places retained in the rounded off value should be the same as that of the specified value in this standard.

Indian Standard

**PUC EQUIPMENT (GAS ANALYZER AND SMOKE METER) —
SPECIFICATION AND TEST METHODS**

1 SCOPE

1.1 It specifies test methods for measurement of Smoke levels, Carbon monoxide, and Hydrocarbon emissions for in-service vehicles.

1.2 It also specifies test methods for testing of PUC equipment used for emission measurements of in-service vehicles.

2 REFERENCE

The standards listed below contain provisions which, through reference in this text, constitute provisions of this standard. At the time of publication, the editions indicated were valid. Standards are subject to revision, and parties to agreements based on this standard are encouraged to investigate the possibility of applying the most recent edition of the standards listed below.

<i>IS/Other standards No.</i>	<i>Title</i>
IS/IEC 60068-2-6: 2007	Environmental Testing Part 2 Tests Section 6 Test Fc: Vibration sinusoidal
IS 9000 (Part 7/Sec 3) : 2019	Environmental Testing Part 7 Tests Section 3 Test Ec: Rough handling shocks, primarily for equipment-types specimens (<i>First Revision</i>)
IS 14700 (Part 4/Sec 3): 2023	Electromagnetic Compatibility (EMC) Part 4 Testing and Measurement Techniques Section 3 Radiated, Radio-Frequency
IEC 61000-4-3: 2020	Electromagnetic Field Immunity Test (<i>Second Revision</i>)

3 TERMINOLOGY

For the purposes of this standard, the following definitions shall apply:

3.1 Sampling Probe — Tube that is introduced into the exhaust tail pipe of a vehicle to take gas samples.

3.2 Water Separator — Water separator device that removes water to a level that prevents condensation within the gas handling system downstream from its location.

3.3 Filter Unit — Device that removes particulate matter from the exhaust gas sample.

3.4 Gas Handling System — All instrument components from the sampling probe to the gas sample outlet, through which the exhaust gas sample is conveyed by the pump.

3.5 Adjustment (of a Measuring Instrument) — Operation of bringing a measuring instrument into a state of performance suitable for its use.

3.6 User Adjustment (of a Measuring Instrument) — Adjustment employing only the means at the disposal of the user.

3.7 Manual Adjustment Facility — Facility allowing the adjustment of the instrument by the user.

3.8 Semi-Automatic Adjustment Facility — Facility allowing the user to initiate an adjustment of the instrument without having the possibility of influencing its magnitude whether the adjustment is automatically required or not.

NOTE — For those instruments that require the values of the calibration gas to be entered manually, the facility is considered to be semi-automatic.

3.9 Automatic Adjustment Facility — Facility performing the adjustment of the instrument as programmed without the intervention of the user, to initiate the adjustment or its magnitude.

3.10 Zero-Setting Facility — Facility to set the indication of the instrument to zero.

3.11 Calibration Gas Adjustment Facility — Facility to adjust the instrument to the value of a calibration gas.

3.12 Internal Adjustment Facility — Facility to adjust the instrument to a designated value without the use of an external calibration gas.

3.13 Warm-Up Time — Elapsed time between the instant power is applied to an instrument and the instant at which the instrument is capable of complying with the metrological requirements.

3.14 Response Time — Time interval between the instant when the instrument is subjected to a specified abrupt change in gas mixture composition and the instant when the response reaches within specified limits of its final steady value.

3.15 Error (of Indication) — Indication of a measuring instrument minus a true value of the corresponding input quantity.

3.16 Intrinsic Error — Error of a measuring instrument, determined under reference conditions.

3.17 Absolute Error of Measurement — Result of a measurement minus the conventional true value of the measurand.

3.18 Relative Error — Absolute error of measurement divided by the conventional true value of the measurand.

3.19 Fault — Difference between the error of indication and the intrinsic error of the instrument.

3.20 Significant Fault — Fault, the magnitude of which is greater than the magnitude of the maximum permissible error on initial verification.

NOTE — The following faults are considered not to be significant.

- a) Fault arising from simultaneous and mutually independent causes in the instrument itself or in its checking facilities;
- b) Faults implying the impossibility to perform any measurement;
- c) Transitory faults being momentary variations in the indication, which cannot be interpreted, recorded or transmitted as a measurement result; and
- d) Faults giving rise to variations in the measurement results that are so large as to be noticed by all users of the instruments.

3.21 Influence Quantity — Quantity that is not the measurand but which affects the result of the measurement.

3.22 Rated Operating Conditions — Conditions of use giving the ranges of the influence quantities for which the metrological characteristics of an instrument are intended to lie within the specified maximum permissible errors.

3.23 Influence Factor — Influence quantity having a value within the rated operating conditions of the instrument.

3.24 Disturbance — Influence quantity having a value within the limits specified in this Chapter but outside the rated operating conditions of the instrument.

3.25 Reference Conditions — Conditions of use prescribed for testing the performance of Instrument or for inter-comparison of results of measurements.

3.26 Checking Facility — Facility that is incorporated in the instrument and that enables significant faults to be detected and acted upon

NOTE — “Acted upon” means any adequate response by the Instrument (luminous or acoustic signal, byblocking of process, etc.)

3.27 Automatic Checking Facility — Checking facility operating without the intervention of the user.

3.27.1 Permanent Automatic Checking Facility (Type P) — Automatic checking facility operating during each measurement cycle.

3.27.2 Intermittent Automatic Checking Facility (Type I) — Automatic checking facility operating at certain time intervals or per fixed number of measurement cycles.

3.28 Test — Series of operations intended to verify the compliance of the equipment under test (EUT) with specified requirements.

3.29 Lambda — Dimensionless value representative of the burning efficiency of an engine in terms of the air/fuel ratio in the exhaust gases and determined with a referenced standardized formula.

3.30 Calibration Gas — Stable gas mixture of known concentration used for periodic calibration of the instruments and for various performance tests.

3.31 Modulus (of a Number) Absolute Value — Value of the number without regard to its sign.

3.32 Hand-Held Instrument — Type of portable instrument that can be transported by one person with its standard accessories, and that rests on a suitable surface during use or mounted on a suitable trolley.

3.33 Spark Ignition Engine — An internal combustion engine in which the combustion of the air/fuel mixture is initiated at given instants by a hot spot, usually an electric spark.

3.34 Idle Speed — The engine rate, in revolution per minute, with fuel system controls (accelerator and choke) in the rest position, transmission in neutral and clutch engaged in the case of vehicles with manual or semi-automatic transmission or with selector in park or neutral position when an automatic transmission is installed, as recommended by the manufacturer.

3.35 Raised Idle Speed — Maintaining the engine rate at 2500 ± 200 , in rpm with fuel system controls (accelerator and choke) in the rest position, transmission in neutral and clutch engaged in the case of vehicles with manual or semi-automatic transmission or with selector in park or neutral position when an automatic transmission is installed, as recommended by the manufacturer.

3.36 Normal Thermal Conditions — The thermal conditions attained by an engine and its drive line after a run of at least 15 min. on a variable course, under normal traffic conditions.

3.37 Compression Ignition Engine — An Internal Combustion Engine that operates on compression ignition principle (Diesel Engines).

3.38 Smoke Density — The light absorption coefficient of the exhaust gases emitted by the vehicle expressed in terms of m^{-1} or in other units such as Bosch, Hartridge, % opacity etc.

3.39 Smoke Meter — An instrument for continuous measurement of the light absorption

coefficient of the exhaust gases emitted by vehicles.

3.40 Maximum Rated Speed — The maximum speed permitted by governor at full load.

3.41 Free Acceleration Test — The test conducted by abruptly but not violently, accelerating the vehicle from idle to full speed with the vehicle Stationary in neutral gear.

4 TECHNICAL SPECIFICATIONS AND TEST PROCEDURE FOR 4 GAS ANALYSER

It specifies the metrological, technical requirements and tests for measuring instruments [hereafter termed 'instrument(s)'], that serve to determine the volume fractions of certain components of the exhaust gases emanating from motor vehicles, and establishes the conditions with which such instruments must comply in order to meet performance requirements.

It covers instruments whose principle of detection is based on infrared absorption in gases for CO, CO₂ and HC. Oxygen is generally measured with a fuel cell. It is not intended, however, to exclude any other types of instruments that although based on other principles of detection meet the specified metrological and technical requirements and satisfy the associated tests. It is applicable to instruments for the inspection and maintenance of in-service vehicles having Spark Ignition (SI) engines (both 2 and 4 stroke).

These instruments are used to determine the volume fraction of one or more of the following exhaust gas components:

- a) Carbon monoxide (CO);
- b) Carbon dioxide (CO₂);
- c) Hydrocarbons (HC, in terms of n-hexane);
- d) Oxygen (O₂) at the moisture level condition of the sample as analyzed; and
- e) Lambda (λ)

4.1 Description of Instruments

4.1.1 The instruments shall provide a means for sampling and then measuring the exhaust gases emitted from the tail pipe of a motor vehicle. A pump shall be provided to transport the gas sample through a gas sample handling system. One or more detection devices may be used and incorporated in the gas handling system to analyze the sample and provide signals related to the volume fractions of gas components of interest, namely CO, CO₂, HC and O₂. The detector signals are then electrically processed to display and record the results of a measurement in volumetric units of the gas components together with other important related information such as a lambda value calculation.

4.1.2 Acceptable overall performance of the instrument is dependent upon its various components for the associated characteristics. An example of an instrument using gas calibration for adjustment is shown in Fig 1.

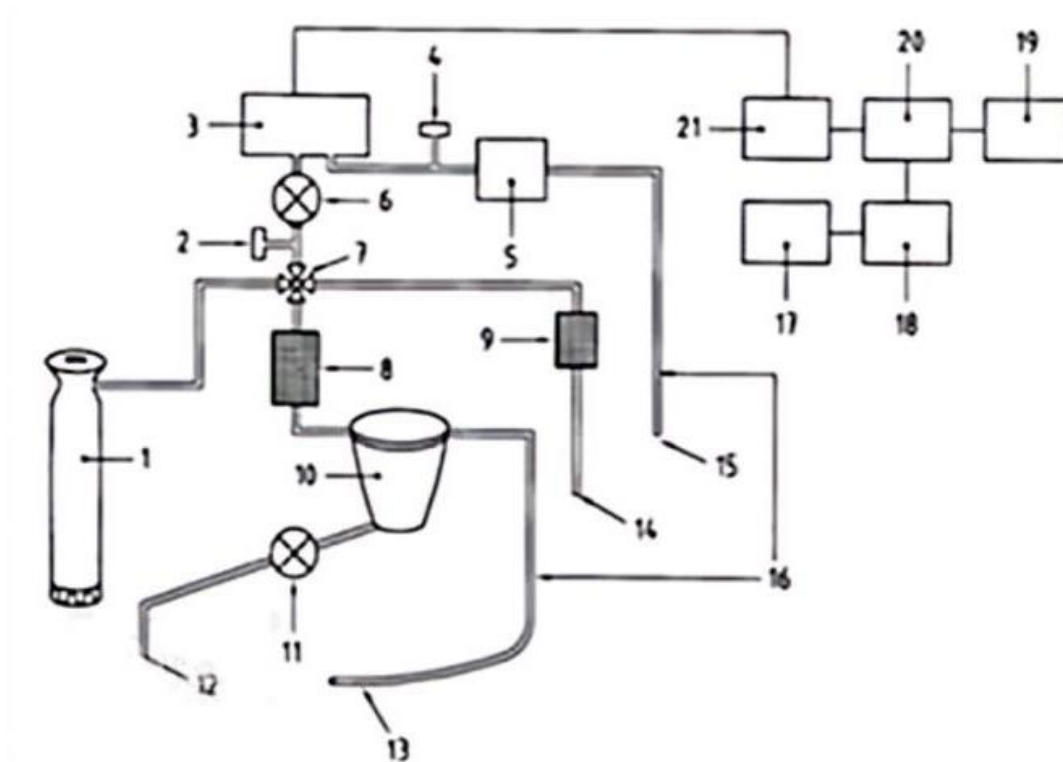

FIG. 1 DIAGRAMMATIC ILLUSTRATION OF AN INSTRUMENT FOR MEASURING VEHICLE EXHAUST EMISSIONS

Where,

1 : Calibration gas input	8 : Filter gas	15 : Gas output
2 : Differential pressure sensor	9 : Charcoal filter	16 : Gas handling system
3 : CO, CO ₂ and HC analysis	10 : Water separator	17 : Seals
4 : Atmospheric pressure sensor	11 : Water pump	18 : Adjustment facilities
5 : O ₂ analysis	12 : Water output	19 : Interfaces
6 : Gas pump	13 : Sampling probe	20 : Indicating device
7 : Electrovalve	14 : Gas input for zero-setting	21 : Signal conversion

4.1.3 Major instrument components are as follows:

4.1.3.1 A sampling probe introduced in the tail pipe of an operating motor vehicle to collect the exhaust gas sample.

4.1.3.2 A hose with associated tubing connected to the probe to provide a path for the gas sample to enter, pass through and exit the instrument.

4.1.3.3 A pump to convey the gases through the instrument.

4.1.3.4 A water separator to prevent water condensation from forming in the instrument.

4.1.3.5 A filter to remove particulate matter that could cause contamination of various sensitive parts of the instrument.

4.1.3.6 Ports downstream from the water separator and filter to introduce ambient air and calibration gas when required by the technology used. The calibration gas port should have a suitable provision for connection to the pressurized 10/47 liters gas cylinders by the means of

¼” teflon tube and compression tube fitting.

4.1.3.7 Detection devices to analyze the gas sample into its components according to volume fractions.

4.1.3.8 A data system to process the signal and an indicating device to display the results of a measurement.

4.1.3.9 A control facility to initiate and check instrument operations and a manual, semi-automatic, or automatic adjustment facility to set instrument operating parameters within prescribed limits.

4.1.3.10 Either a built-in printer and/or an RS 232 serial interface or USB or TCP/IP ethernet or Wireless interface through which the data can be transferred to a PC or any other peripheral device.

4.1.4 The instrument will be supplied with an exhaust extension pipe as a standard accessory. The extension pipe connection should be leak proof and should be universally adaptable to the exhaust pipe, where probe insertion of 300 mm is not possible.

4.2 Metrological Requirements

4.2.1 Indication of the Measured Result

The volume fractions of the gas components shall be expressed as a percentage (% vol) for CO, CO₂ and O₂ and in parts per million (ppm vol) for HC. The permanent inscriptions for these units or electronic display shall be assigned unambiguously to the indication, for example % vol CO , % vol CO₂, % vol O₂ and ppm vol HC, corrected CO and Lambda and RPM (idle or High Idle).

4.2.2 Measuring Range

The minimum indicating ranges shall be as follows:

Gas Component	Minimum Indicating Range
CO	0-5% vol
CO ₂	0-16% vol
HC	0-10000 ppm vol
O ₂	0-21% vol

4.2.3 Resolution of Indication

4.2.3.1 Digital indication

Digital figures shall be at least 5 mm high. The least significant figure of the display shall provide a resolution equal to or one order of magnitude higher than the values given in following table:

Gas Component	Minimum Resolution
CO	0.01% vol
Corrected CO	0.01% vol
CO ₂	0.1% vol
HC	1 ppm vol

O ₂	0.02% vol for measurand values ≤ 4 % vol and 0.1% vol for measurand values > 4% vol
----------------	--

4.2.4 Maximum Permissible Errors

4.2.4.1 Maximum permissible intrinsic errors

Maximum permissible errors shall apply for an instrument under the reference conditions as per following table:

Gas Component	Maximum Permissible Intrinsic Error
CO	Absolute: ±0.06 vol Relative: ±3% (whichever is greater)
CO ₂	Absolute: ±0.4% vol Relative: ±4% (whichever is greater)
HC	Absolute: ±12 ppm vol; Relative: ±5%, whichever is greater
O ₂	Absolute: ±0.1% vol; Relative: ±3%, whichever is greater

4.2.4.2 Maximum permissible errors on initial verification

Maximum permissible errors shall apply for an instrument at initial verification under the rated operating conditions as per following table.

Gas Component	Maximum Permissible Error on Initial Verification
CO	Absolute: ±0.06 vol; Relative: ±5%, whichever is greater
CO ₂	Absolute: ±0.5% vol; Relative: ±5%, whichever is greater
HC	Absolute: ±12 ppm vol; Relative: ±5%, whichever is greater
O ₂	Absolute: ±0.1% vol; Relative: ±5%, whichever is greater

4.2.4.3 Maximum permissible errors on subsequent verification

The maximum permissible errors on subsequent verification shall be equal to the errors on initial verification.

4.2.5 Influence Quantities

4.2.5.1 Reference conditions

- a) Temperature: 25° C ± 2° C ;
- b) Relative Humidity: 60% ± 10% ;
- c) Atmospheric Pressure: Stable ambient ;

- d) Mains voltage: $\pm 2\%$ Nominal voltage, $\pm 1\%$, Nominal frequency ; and
- e) Presence of influencing gas components: None except the measurands in N₂.

NOTES —

- 1) In case of Infrared technology, a relative humidity range from 30% to 60% is acceptable.
- 2) Equipment, which are calibrated on site, the above condition may not be applicable and condition will depend on ambient condition.

4.2.5.2 *Rated operation conditions*

- a) Temperature: 5° C to 45° C ;
- b) Relative Humidity: up to 90% ;
- c) Atmospheric Pressure: 860 hPa to 1060 hPa ; and
- d) Mains voltage variation: -15% to $+10\%$ of the nominal voltage, $\pm 2\%$ of the nominal frequency.

If a battery is used to power the instrument, the limits of power supplied shall be within the instrument manufacturer's specifications. In case the battery power drops outside the limits, there should be an indication on the instrument and it should not be possible to make any measurement with the instrument. If a portable generator is used, its requirements shall comply with the specifications for the mains voltage.

4.2.5.3 *Influence of gases other than the measurand (Cross sensitivity)*

The design of the instruments shall be such that measurements do not vary by more than half the modulus of the maximum permissible error on initial verification when gases other than the measurand are present in the following maximum volume fractions:

- a) 16% vol CO₂;
- b) 6% vol CO;
- c) 0.3% vol NO;
- d) 5% vol H₂;
- e) 10% vol O₂;
- f) 5000 ppm vol HC (as n-hexane); and
- g) Water vapour up to saturation.

However, the presence of H₂ is not necessary for testing the O₂ channel and the presence of H₂ and O₂ is not necessary in case of Infrared technology.

4.2.6 *Disturbances*

Significant faults (as defined in significant fault) shall not occur or shall be detected and acted upon by means of checking facilities for the following disturbances:

- a) Mechanical shock and vibrations;
- b) Short time power reductions;
- c) Bursts from the mains (transients);
- d) Electrostatic discharges;
- e) Radiated radio frequency electromagnetic fields; and
- f) Mains frequency magnetic fields.

4.2.7 *Response Time*

For measuring CO, CO₂ and HC, instrument including the specified gas handling system shall indicate 95% of the final value (as determined with calibration gases) within 15s or less after changing from a gas with zero content. For measuring O₂ the instruments shall indicate a value differing less than 0.1% vol of the final value within 60s after changing from air to oxygen-free calibration gas.

4.2.8 Warm-Up Time

After the warm-up time, the instruments shall meet the metrological requirements as stated in this standard. Instruments shall have the means to prevent measurement and an indication of measured gas volume fractions during the warm-up time. Instruments shall have a warm-up time not exceeding 10 min.

4.2.9 Propane/Hexane Equivalency Factor

The content of hydrocarbons shall be expressed in ppm vol n-hexane (C₆H₁₄) equivalent. The adjustment may be carried out using propane (C₃H₈). Therefore, a conversion factor referred to as “C₃ / C₆ Equivalence Factor”, or PEF, shall be permanently and conspicuously marked or easily displayed on each instrument. Alternatively, display of an array of conversion factors is allowed provided that the associated volume fractions are also displayed. The manufacturer shall provide the conversion factor(s) for each individual instrument to three significant figures. If the gas-sensitive element is replaced or repaired, the new conversion factor(s) shall be attached to the instrument. For instruments with one single conversion factor, the measuring values obtained when tested with n-hexane shall not differ by more than the applicable maximum permissible error from the curve established with propane. For instrument capable of displaying an array of conversion factors, the measuring values obtained when tested with n-hexane shall not differ by more than half the value of the applicable maximum permissible error from the curve established with propane.

NOTE — The value for this factor is usually between 0.490 and 0.540.

4.2.10 Lambda Calculation

Instruments equipped with a lambda indication shall carry out the appropriate calculation for different fuel options such as petrol, CNG, LPG with a suitable formula for lambda values between 0.8 and 1.2, the maximum permissible error in the calculation with respect to the resolution and the application of the chosen formula shall not exceed 0.3%. For this purpose, the conventional true value will be calculated according to the following formula:

$$\lambda = \frac{[CO_2] + \frac{[CO]}{2} + [O_2] + \left\{ \left(\frac{H_{cv}}{4} \times \frac{3.5}{3.5 + \frac{[CO]}{[CO_2]}} - \frac{O_{cv}}{2} \right) \times ([CO_2] + [CO]) \right\}}{\left(1 + \frac{H_{cv}}{4} - \frac{O_{cv}}{2} \right) \times \{ ([CO_2] + [CO]) + (K_1 \times [HC]) \}}$$

Where,

- (i) [] = is the concentration in % vol, for HC only in ppm vol;
- (ii) K₁ = is the conversion factor for HC if expressed in ppm vol n-hexane (C₆H₁₄) equivalent. Its value in this formula is 6x10⁻⁴;
- (iii) H_{cv} = is the atomic ratio of hydrogen to carbon in the fuel. The arbitrary value is 1.7261; and
- (iv) O_{cv} = is the atomic ratio of oxygen to carbon in the fuel. The arbitrary value is 0.0176

The lambda value shall be displayed digitally to four figures and shall be identified by an

appropriate symbol or sign (for example, lambda or λ) in any of the following format:

$$\text{Lambda} = \text{x.xxx} \text{ or } \lambda = \text{x.xxx}$$

For analyzers not equipped with oxygen channel but capable of calculating A/F ratio (air to fuel) an A/F / Lambda indication shall be carried out using a suitable formula. The details of the formula will be provided.

For lambda values between 0.8 and 1.2, the maximum permissible error in the calculation with respect to the resolution and the application of the chosen formula shall not exceed 0.3%. For this purpose, the conventional true value will be calculated according to the following formula.

$$\text{Lambda} = 1 / \text{AF}$$

$$\text{A/F} = 2.088 \times \frac{100 + 0.46\text{CO}_2 + 0.060\text{CO} - \text{THC}}{\text{CO}_2 + \text{CO} + \text{THC}}$$

Where,

CO, CO₂ are vol (%); and

THC in vol (%) C₁.

4.2.11 Stability with Time or Drift

When used in accordance with the manufacturer's operating instructions, the measurements made by the instruments, under stable environmental conditions and after adjustment using a calibration gas or the internal adjustment facility, shall remain within the maximum permissible errors on initial verification for at least 4 h without the need for calibration gas or internal re-adjustments by the user.

If the instruments are equipped with a means for drift compensation, such as automatic zero or automatic internal adjustment, then the action of such adjustments control shall not produce an indication / display that can be confused with a measurement of an external gas. It should not be possible to pass the gas sample and measure the same while the automatic adjustments are in process.

4.2.12 Repeatability

For 20 consecutive measurements, using the same calibration gas mixture, carried out by the same person with the same instrument within relatively short time interval the experimental standard deviation of the 20 results shall not be greater than one third of the modulus of the 'maximum permissible error on initial verification' taken from 4.2.4.2 for the relevant gas mixture.

4.2.13 Engine Speed Measurement System

The speed measurement range of the measurement system shall be minimum from 200 to 6000 rpm with the resolution of 10 rpm. The accuracy of speed measurement shall be ± 20 rpm or $\pm 2\%$ of the reading, whichever is greater and the rpm display shall be updated at least at 0.5 s time interval.

Alternately, the engine speed may be measured through the On-board diagnostic (OBD) port of the vehicle under test and electronically communicated to the gas analyzer.

4.3 Technical Requirements

4.3.1 Construction

4.3.1.1 All components of the sample gas handling system shall be made of corrosion-resistant

material in particular, the material of the sampling probe shall withstand the exhaust gas temperature. The materials used shall not influence the composition of the gas sample.

4.3.1.2 The sampling probe shall be so designed that it can be inserted at least 300 mm into the exhaust tail pipe of the vehicle and held in place by a retaining device regardless of the depth of insertion.

4.3.1.3 The sample gas handling system shall contain a filter with reusable or replaceable filter elements capable of removing dust, soot or like particles larger than 5 µm in diameter. It shall be possible to use the instruments for a period of at least 15 min with exhaust gas from a specially adjusted test engine having an HC fraction concentration of approximately 6000 ppm. It shall be possible to observe the degree of a filter's contamination without its removal, and it shall also be possible to replace, when necessary, this filter easily without special tools.

4.3.1.4 The sample gas handling system shall contain a water separator to prevent water condensation from forming in the measuring transducer. In the case of saturation of the separator, it shall empty automatically or manually. In any case the measurement operation shall be automatically stopped if there is a danger of water going inside the measuring transducer with water filled in the water separator.

4.3.1.5 In addition to the probe, instruments equipped with an HC measurement channel shall have following:

- a) A port for drawing in ambient air or other gas without hydrocarbons to provide a reference for zero-setting of the measuring instrument. For this purpose, ambient air shall pass through a charcoal filter or equivalent system. Instruments without an HC channel may also be equipped with this additional port. Oxygen measuring cells cannot use ambient air for zero- setting. If zero-setting is required, an oxygen-free gas should be used; and
- b) Another additional port shall be provided in the sample gas handling system for introducing calibration gas.

Both ports shall be located downstream of the water separator and filter unit in order to minimize potential contamination of the gases introduced.

A means shall be provided to maintain the same pressure within the detector during zero setting, gas calibration, and sampling.

4.3.1.6 The sampling pump conveying the exhaust gas shall be mounted so that its vibrations do not affect the measurements. It shall be possible to turn the pump on and off separately from the other instrument components by the user however, it shall not be possible to make a measurement when the pump is switched off. Instrument is required to purge and back-flush the sample gas handling system automatically with ambient air before the pump is switched off.

4.3.1.7 The instruments shall be equipped with a device that indicates when the gas flow rate decreases to a level that would cause the detection to exceed the response time and/or half the modulus of the maximum permissible error on initial verification and when that limit is reached, the device shall prevent measurements.

4.3.1.8 The sample gas handling system shall be airtight to such an extent that the influence of dilution with ambient air on the measuring results shall not be more than specified below:

- a) For CO, CO₂ and HC : Half the modulus of the 'maximum permissible error on initial verification'
- b) For O₂ : 0.1 % vol

A leakage test system / device along with procedure with sufficient accuracy to detect this specific maximum leakage shall be provided in the manufacturer's operating instructions.

Instruments shall not be able to make a measurement if this value is exceeded.

4.3.1.9 The instrument shall be equipped with an RS 232 / USB / TCP/IP Ethernet /Wireless interface permitting coupling to any peripheral devices or instruments. Any such interface shall not allow the metrological functions of the instruments or their measurement data to be inadmissibly influenced by the peripheral devices, by other interconnected instruments, or by disturbances acting on the interface. Functions that are performed or initiated via an interface shall meet the relevant requirements and conditions of the clause technical requirement.

If the Instrument are connected to a data printer / PC / any other peripheral device, through wired or wireless interface then the data transmission from the Instrument to such peripheral device shall be designed so that the results cannot be falsified. It shall not be possible to measure and or print out a document or test report or test certificate for legal purposes, if the Instrument checking facility(s) detect(s) a significant fault or a malfunction in the Instrument.

4.3.2 *Adjustment Facilities*

4.3.2.1 The Instrument shall have an adjustment facility that provides operations for zero-setting, gas calibration (if applicable), and internal adjustment.

4.3.2.2 The facility shall be automatic for zero-setting and internal adjustment.

4.3.2.3 The internal adjustment shall neither influence the adjusted zero nor the linearity of the response of the Instruments and these shall be coupled to any adjustment made with a calibration gas. A method for coupling shall be provided such that each time a gas calibration is conducted, the gas value and the internal adjustment value are adjusted and the indication equals the calibration gas value.

4.3.2.4 Instrument shall be provided with a means to observe negative indications near zero for certain tests.

4.3.3 *Security of Operation*

4.3.3.1 The instruments shall be designed and manufactured such that when exposed to any of the disturbances listed in 4.2.6.

Significant faults do not occur or are detected and acted upon by means of a checking facility. If this is achieved by the use of automatic self-checking facilities, then it shall be possible to check the correct functioning of such facilities.

4.3.3.2 The Instruments with an HC-channel shall be equipped with a checking facility for detecting HC gas residues. This facility serves to ascertain that before a measurement is made the value indicated is less than 20 ppm vol n- hexane for an ambient air sample taken through the probe.

4.3.3.3 Instrument shall not be able to make a measurement if the HC residue value exceeds 20 ppm vol n-hexane. If the measuring instrument are provided with the measuring cycle, this requirement shall be fulfilled at the beginning of each measuring cycle otherwise the manufacturer shall indicate what constitutes the beginning of the measurement.

4.3.3.4 Instruments with an O₂-channel shall be equipped with a device for automatically recognizing any malfunctioning of the sensor due to aging or a break in the connecting line.

4.3.3.5 Instrument shall be controlled by an automatic self-checking facility that shall operate in such a way that before a measurement can be indicated or printed, all internal adjustments, calibration gas adjustments, and all other checking facility parameters shall be confirmed for

proper values or status (i.e. within limits). The semi or automatic checking facility for the instrument, as a minimum requirement shall cover following:

- a) Warm-up check: Permanent Automatic;
- b) Low flow and Leak check: Always on POWER ON;
- c) Gas calibration check: Once in a day; and
- d) HC residue check: Always on POWER ON and before each measurement.

4.3.3.6 Instruments and peripheral devices like PC equipped with an automatic adjustment facility or a semi-automatic adjustment facility shall not be able to make a measurement until correct adjustments have been completed.

4.3.3.7 Instruments and peripheral devices like PC equipped with a semi-automatic adjustment facility shall not be able to make a measurement when an adjustment is required.

4.3.3.8 A means for warning of a required adjustment may be provided for both automatic and semi-automatic adjustment facilities.

4.3.3.9 Effective sealing devices shall be provided on all parts of the Instrument that cannot be materially protected in another way against operations liable to affect the accuracy or the integrity of the instruments. This applies in particular to:

- a) Adjustment means;
- b) Peripheral hardware;
- c) Software integrity; and
- d) Disposable oxygen fuel cell.

4.3.3.10 For instruments without a pressure-compensating device, daily calibration is required. The operating instructions shall contain this requirement.

4.3.3.11 A battery-operated instrument shall either continue to function correctly or not indicate any values whenever the voltage is below the manufacturer's specified value.

4.4 Marking

The instruments shall have a permanent and easily readable label or labels giving the following information:

- a) Manufacturer's trade mark/corporate name;
- b) Year of manufacture;
- c) Serial number of the instrument and of the measuring transducer;
- d) Minimum and nominal flow rate;
- e) Nominal mains voltage, frequency and power required;
- f) Gas components and respective maximum measured value; and
- g) Type description and model of the oxygen fuel cell.

Furthermore, the value of the propane/hexane equivalency factor for each instrument shall be marked permanently on the front panel of the instrument or shall be displayable on the indicating device. In the case where more than one single propane / hexane equivalency factor is available, these factors shall be displayed with the associated concentrations.

4.5 Operating Instructions

4.5.1 The manufacturer shall provide written operating instructions for each instrument in the English language.

4.5.2 The operating instructions shall include:

- a) The time intervals and the procedures for adjustment and maintenance that shall be followed to comply with the maximum permissible errors;
- b) A description of the leakage test procedure;

- c) An instruction for the user to conduct an HC-residue check prior to each HC measurement, including a description of the HC-residue check procedure;
- d) The maximum and minimum storage temperatures;
- e) A specification of the voltage and frequency required of any portable generator consistent with 4.2.5.2, taking into account varying load conditions typical of those encountered at the location of use;
- f) A statement of the rated operating conditions;
- g) In case a lambda value is calculated, a description of the applied formula;
- h) An instruction for the replacement of the oxygen fuel cell; and
- j) The description of the possible errors along with test data if the instrument is used for the temperature up to 50 °C and frequency variations of 48 to 52 Hz.

4.6 Performance Tests for 4 Gas Analyzer

4.6.1 Calibration Curve

The errors of the Instruments shall be determined separately for each measurand and for at least five values within their measuring range using the recommended volume fractions. The measurements shall be performed successively:

	1 st	2 nd	3 rd	4 th	5 th
CO	0.2% vol	0.3% vol	0.5% vol	1% vol	3.5% vol and/or 5% vol
CO₂	6% vol	10% vol	14% vol	--	--
HC	200 ppmvol	500 ppm vol	1000 ppm vol	5000 ppm vol	7000 ppm vol
O₂	0.5% vol	10% vol	20.9% vol	--	--

4.6.2 Stability with Time or Drift

This test shall be conducted for a period of 4 h following the warm-up time. Measurements shall be performed at least every half-hour using the following gas mixtures.

Measurand	Volume fraction of measurand
CO	0.5% vol
CO ₂	14% vol
HC	1000 ppm vol
O ₂	0.5% vol

4.6.3 Repeatability

The test procedure specified in 4.2.12 shall be carried out with the recommended volume fractions.

Measurand	Volume fraction of measurand
CO	0.5% vol
CO ₂	14% vol

HC	1000 ppm vol
O ₂	0.5% vol

4.6.4 Dry Heat Test

This test consists of exposure of the instruments to a temperature of 45° C under ‘free air’ conditions for 2 h (the time duration specified begins after the instrument has reached temperature stability). During the test, the rate of change in temperature shall not exceed 1° C/min during heating up and cooling down, and the relative humidity in the testing atmosphere shall not exceed 50%.

The following calibration gas shall be supplied to the probe at ambient pressure (to within 750 Pa). During the test, one measurement shall be performed every half-hour using the two mixtures composed of the recommended volume fractions.

Measurand	1 st mixture	2 nd mixture
CO	0.5% vol	3.5% vol
CO ₂	14% vol	14% vol
HC	1000 ppm vol	5000 ppm vol
O ₂	0.5% vol	0.5% vol

The tests will be repeated at 50° C also and the results of the test will be noted.

4.6.5 Cold Test

This test consists of exposure of the instruments to a temperature of 5° C under ‘free air’ conditions for 2 h (the time duration specified begins after the Instruments have reached temperature stability). During the heating up or cooling down of the Instrument, the rate of change in temperature shall not exceed 1° C/min.

Measurand	1 st mixture	2 nd mixture
CO	0.5% vol	3.5% vol
CO ₂	14% vol	14% vol
HC	1000 ppm vol	5000 ppm vol
O ₂	0.5% vol	0.5% vol

4.6.6 Damp Heat, Steady State Test

This test consists of exposure of the instruments to a constant temperature of 30° C and a constant relative humidity of 85 % for two days. The exposure shall be such that water does not condense on the instruments. The temperature is deemed to be steady when the difference between the extreme temperatures does not exceed 5° C, and the rate of change does not exceed 5° C/h.

The following calibration gas shall be supplied to the probe at ambient pressure (to within 750 Pa). During the test one measurement shall be performed every half-hour using the two mixtures composed of the recommended volume fractions.

Measurand	1 st mixture	2 nd mixture
CO	0.5% vol	3.5% vol
CO ₂	14% vol	14% vol

HC	1000 ppm vol	5000 ppm vol
O ₂	0.5% vol	0.5% vol

4.6.7 Atmospheric Pressure Test

The test consists of measurements under the extreme pressures of the rated operating conditions or extreme pressures outside these limits when specified by the manufacturer. The extreme values shall be reached gradually from stable ambient pressure conditions and shall then be kept stable for 30 min before starting the below specified measurements.

Test gases shall be supplied at the probe at ambient test pressure (to within 750 Pa). At least two measurements shall be performed at each extreme pressure value using two mixtures composed of the recommended volume fractions. The errors observed shall be within the limits of the maximum permissible errors as specified in 4.2.4.2 on initial verification for each measurement.

NOTE — If an automatic or semi-automatic adjustment is part of the pressure compensation process, care must be taken to ensure that the measurements at both extreme pressure values are performed after such adjustment has been carried out.

Measurand	1 st mixture	2 nd mixture
CO	0.5% vol	3.5% vol
CO ₂	14% vol	14% vol
HC	1000 ppmvol	5000 ppm vol
O ₂	0.5% vol	0.5% vol

4.6.8 Power Supply Variation Test

4.6.8.1 The A.C. power supply test consists of exposure of the instruments to extreme values of the nominal power supply voltage and nominal frequency for a period long enough to perform the required measurement under following variation conditions:

- a) **Voltage:** Nominal Voltage (230V), +10% ~ -15%
- b) **Frequency:** Nominal Frequency (50 Hz), ± 1 Hz.

The A.C. power supply test will be repeated with frequency of 50 Hz ± 2 Hz also.

4.6.8.2 The D.C. Power Supply test consists of exposure of the instruments to the specified power supply conditions for a period long enough to perform the required measurement. The upper tolerance limit shall be as specified by the manufacturer. The lower tolerance limit shall be the lowest voltage at which the instrument provides measurement results.

4.6.8.3 While the instruments are exposed separately to each type of mains variation as indicated in 4.6.8.1 or 4.6.8.2 above the measurements shall be performed using following volume fractions of Gas Mixtures.

Measurand	Volume fraction of measurand
CO	0.5% vol

CO ₂	14% vol
HC	1 000 ppm vol
O ₂	0.5% vol

The A.C. power supply test will be repeated at 50° C also.

4.6.9 Influence of Gases Other than the Measurand (Cross Sensitivity)

4.6.9.1 The cross sensitivity shall be determined by the following two tests:

4.6.9.1.1 Test with N₂ alone

- Supply the instrument with N₂ alone;
- Supply the instrument successively with each influencing gas alone in N₂ at its maximum value as specified in 4.2.5.3; and
- Compare the 'zero' responses of the instruments determined in 4.6.9.1.1(a) and 4.6.9.1.1(b) for each measurand. The difference of indications shall meet the requirement specified in 4.2.5.3 for 'ZERO'.

4.6.9.1.2 Test with all measurands in N₂

- Supply the Instrument with a measurand in N₂ alone. Repeat the operation for the other measurands;
- Supply the Instrument with all measurands together in N₂; and
- For each measurand, the difference between the errors of the Instruments determined in 4.6.9.1.2(a) and the error determined in 4.6.9.1.2(b) shall meet the requirements specified in 4.2.5.3.

4.6.9.2 For above test and for instruments that detect with infra-red absorption and for O₂ channel, the following volume fractions of gas mixture is required.

For the measurands in N₂:

<i>Measurand</i>	<i>Volume fraction of measurand</i>
CO	3.5% vol
CO ₂	14% vol
HC	1000 ppm vol

Referring to 4.2.5.3, if the presence of O₂ and H₂ is necessary, two different gas mixtures shall be used to avoid explosive risk. The recommended volume fractions for the measurands in N₂ are as per the following table:

<i>Mixture A</i>	<i>Mixture B</i>
3.5% vol CO	3.5% vol CO
14% vol CO ₂	14% vol CO ₂
1000 ppm vol HC	5000 ppm vol HC
10% O ₂	5% H ₂

4.6.10 Mechanical Shock and Vibrations Test

4.6.10.1 For mechanical shock testing, the tested instrument shall be placed in its normal position of use on a rigid surface. It shall be tilted on one bottom edge and then allowed to fall freely onto the test surface. The following conditions as per IS 9000 (Part 7/Sec 3) shall be applied:

- a) Height of fall : 25 mm
- b) Number of falls : 1 on each bottom edge

4.6.10.2 Vibration test shall be conducted as specified in IS/IEC 60068-2-6. Analyser shall be subjected to vibration in normal mounting axis for 5 to 9 Hz \pm 3 mm displacement and 9 to 150 Hz \pm 1 g acceleration amplitude, preferably with electrical power 'ON' condition. This test shall be repeated for other two axes also. However, during the test the instrument shall be mounted in its normal position only.

4.6.10.3 Before and after the test, measurements shall be performed using following volume fractions of gas mixture:

Measurand	Volume Fraction of Measurand
CO	0.5 % vol
CO ₂	14 % vol
HC	1000 ppm vol
O ₂	0.5 % vol

4.6.11 *Short Time Power Reductions Test*

4.6.11.1 A test generator suitable for reducing the amplitude of the A.C. mains voltage shall be used. It shall be adjusted before being connected to the instruments. The mains voltage interruptions and reductions shall be repeated 10 times with an interval of at least 10 s between successive disturbances. 100 % reductions shall be effectuated for duration of 10 ms 50 % reductions shall be effectuated for duration of 20 ms.

4.6.11.2 During the test, measurements shall be performed using the following volume fractions of gas mixture:

Measurand	Volume Fraction of Measurand
CO	0.5 % vol
CO ₂	14 % vol
HC	1000 ppm vol
O ₂	0.5 % vol

4.6.12 *Burst from the Mains (Transients)*

4.6.12.1 The test consists of exposure of the instruments to bursts of voltage spikes of 1 kV and having a double exponential waveform. Each spike shall have a rise time of 5 ns and a half amplitude duration of 50 ns. The burst length shall be 15 ms, the burst period (repetition time interval) shall be 300 ms. Repetition frequency of the impulses and peak values of the output voltage on 50 Ω load (5 kHz \pm 1 kHz). The transient generator shall have an output impedance of 50 Ω and shall be adjusted before connecting the instrument. At least 10 positive and 10 negative bursts randomly phased shall be applied. Insertion of blocking filters in the cables to the instrument may be necessary to prevent the burst energy being dissipated in the mains.

4.6.12.2 During the test, measurements shall be performed using the following volume fractions of gas mixture:

Measurand	Volume Fraction of Measurand
CO	0.5 % vol
CO ₂	14 % vol
HC	1000 ppm vol
O ₂	0.5 % vol

4.6.13 *Electrostatic Discharges Test*

4.6.13.1 A capacitor of 150 pF shall be charged by a suitable DC voltage source of 6 kV in

contact mode and 8 kV in air mode. Then it shall be discharged through the instrument by connecting one terminal to the instrument's ground chassis and the other through a 330 Ω resistance to the instrument's surfaces that are normally accessible to the user. At least 10 successive discharges shall be applied with a time interval between discharges of at least 10 s. An instrument not equipped with a grounding terminal shall be placed on a grounded plane surface that projects beyond the instrument by at least 0.1 m on all sides. The associated grounded connection to the capacitor shall be as short as possible.

4.6.13.2 In the contact discharge mode, to be carried out on conductive surfaces, the electrode shall be in contact with the instrument and the discharge shall be actuated by the discharge switch of the generator.

In the air discharge mode, on insulating surfaces, the electrode is approached to the instrument and the discharge occurs by spark.

4.6.13.3 During the test, measurements shall be performed using the following volume fractions of gas measurand:

Measurand	Volume Fraction of Measurand
CO	0.5 % vol
CO ₂	14 % vol
HC	1000 ppm vol
O ₂	0.5 % vol

4.6.14 *Radiated, Radio Frequency, Electromagnetic Fields Test*

4.6.14.1 Instrument shall be exposed to electromagnetic field strength as follows:

Frequency range	: 26 MHz to 1000 MHz
Field strength	: 10 V/m
Modulation	: 80 % AM, 1 kHz sine wave

4.6.14.2 The field strength may be generated in the following ways:

- a) Absorber Lined Shielded Enclosure (ALSE) Chamber for all frequency ranges;
- b) A strip line for low frequencies for small instruments from DC to 150 MHz;
- c) A TEM cell (Transverse Electromagnetic Mode cell) for higher frequencies, up to 1 GHz;
- d) A biconical antenna (26 MHz to 300 MHz); and
- e) A log periodic antenna (100 MHz to 1000 MHz)

The specified field strength shall be established prior to the actual testing (without the instruments in the field). When the test is carried out in a shielded enclosure to comply with international laws prohibiting interference to radio communications care needs to be taken to handle reflections from walls. Anechoic shielding may be necessary.

4.6.14.3 During the test, measurements shall be performed using the following volume fractions of gas mixture, as per IS 14700 (Part 4/Sec 3):

Measurand	Volume Fraction of Measurand
CO	0.5 % vol
CO ₂	14 % vol
HC	1000 ppm vol
O ₂	0.5 % vol

4.6.15 *Mains Frequency Magnetic Fields Test*

The Instrument tested shall be exposed in all directions to a magnetic field of 30 A/m at mains frequency. During the test, measurements shall be performed using the following volume fractions of gas measurand:

Measurand	Volume Fraction of Measurand
CO	0.5 % vol
CO ₂	14 % vol
HC	1000 ppm vol
O ₂	0.5 % vol

4.6.16 Warm-Up Time

4.6.16.1 At reference conditions and at 5° C, the warm-up time test to verify compliance with 4.2.8 shall consist of the following steps:

- a) Stabilize the Instrument at each temperature;
- b) Let the Instrument warm up;
- c) Immediately after either the manufacturer's prescribed warm-up period has elapsed or an automatic warm-up lockout has been de-activated, perform a volume fraction measurement (with any necessary internal adjustment being performed prior to this measurement); and
- d) At time intervals of 2 min, 5 min and 15 min after warm-up, perform a measurement with the same calibration gas as above.

The difference between any of the measured values above shall not exceed the modulus maximum permissible error on initial verification.

NOTE — At reference conditions, the warm-up time test may be included with the drift test.

4.6.17 Response Time

4.6.17.1 A measurement shall be taken to determine the time required for an instrument to respond to a calibration gas after sampling ambient air supplied at the probe. A means shall be employed for instantly changing from sampling ambient air to sampling calibration gas through the sample gas inlet probe. The gases shall be supplied at the probe inlet at ambient pressure (to within 750 Pa). The response time shall not exceed the appropriate values specified in 4.2.7.

4.6.17.2 The following recommended volume fractions shall be used:

Measurand	Volume Fraction of Measurand
CO	0.5 % vol
CO ₂	14 % vol
HC	1000 ppm vol
O ₂	0.5 % vol

4.6.18 Low Flow

4.6.18.1 A measurement shall be performed with a calibration gas that is initially supplied to the as handling system at a gas flow rate greater than the minimum required by the tested instrument. During the measurement, the gas flow rate shall be reduced until the low flow indicator responds according to requirements of 4.3.1.7.

4.6.18.2 The following recommended volume fractions shall be used:

Measurand	Volume Fraction of Measurand
CO	0.5 % vol
CO ₂	14 % vol
HC	1000 ppm vol
O ₂	0.5 % vol

4.6.19 Leakage

When following gas mixture is used, the adjustment of the leakage and the test shall be performed successively for each component

Measurand	Volume Fraction of Measurand
CO	0.5 % vol
CO ₂	14 % vol
HC	1000 ppm vol
O ₂	0.5 % vol

4.6.19.1 An adjustable leak shall be introduced artificially into the gas handling system near the pump where a leak of an appropriate orifice size will have the greatest effect on the measurement. With this artificial leak closed, a calibration gas shall be supplied at the probe at ambient pressure (to within 750 Pa).

4.6.19.2 While sampling the calibration gas, record the indication, then adjust the leakage rate so that the indication of the calibration gas differs from the value indicated previously (without the leak) by an amount equal to the requirement of 4.3.1.8.

4.6.19.3 Without disturbing the artificial leak, remove the calibration gas supplied at the probe, and conduct the leakage test procedure as described in the manufacturer's operating instructions.

NOTE — Since the leakage test is performed by introducing air in to the system, the calibration gas supplied at the probe should have a volume content of O₂ close to 0 %.

4.6.20 HC Residue

4.6.20.1 The exhaust of a specially adjusted test engine shall be sampled for at least 5 min by an Instrument in thermal equilibrium at 5°C. The exhaust gas shall contain at least 5% CO and 3000 ppm HC. Immediately after the sampling, conduct an HC residue check as described by the manufacturer's operating instructions. Repeat this operation as many times as necessary to obtain an HC residue that complies with the requirement of 4.3.3.2.

4.6.20.2 Then following calibration gases shall be supplied at the probe at ambient pressure (to within 750 Pa) to check compliance with the maximum permissible error on initial verification:

Measurand	Volume Fraction of Measurand
CO	3.5 % vol
HC	5000 ppm vol

4.6.21 Filter Unit

4.6.21.1 At reference conditions, the instrument shall be exposed to exhaust gases from a specially adjusted test engine for a period of at least 15 min. The exhaust gas shall contain at least 5% CO and 6000 ppm HC. Immediately after the sampling, conduct an HC residue check as described by the manufacturer's operating instructions. Repeat this operation as many times as necessary to obtain an HC residue that complies with requirements of 4.3.3.2. The instrument shall be checked immediately with a calibration gas that shall be supplied to the gas handling system at ambient pressure (to within 750 Pa). The instrument shall comply with the requirements for the maximum permissible error on initial verification and for the response time.

4.6.21.2 The test shall be carried out using the following gas mixture:

Measurand	Volume Fraction of Measurand
CO	3.5 % vol
CO ₂	14 % vol

HC	1000 ppm vol
O ₂	0.5 % vol

4.6.22 *Water Separator*

4.6.22.1 The water separator shall be subjected to the following mentioned in **4.6.22.1.1** and **4.6.22.1.2**

4.6.22.1.1 *High temperature test*

Stabilize the instrument at 45°C, and expose the instrument to water saturated N₂ at 45°C, or water saturated ambient air at 45°C, supplied to the gas handling system for 30 min.

4.6.22.1.2 *Low temperature test*

Stabilize the instrument at a low ambient temperature within the rated operating conditions, and expose the instrument to exhaust gases from any car attached to the probe for 30 min.

4.6.22.2 After each test, the instrument shall be checked immediately with the following gas mixture:

Measurand	Volume Fraction of Measurand
CO	3.5 % vol
CO ₂	14 % vol
HC	5000 ppm vol
O ₂	0.5 % vol

It shall comply with the requirements of the maximum permissible error on initial verification and with the response time requirements of **4.2.7**, before and after the test.

4.6.23 *Propane/Hexane Equivalency Factor*

4.6.23.1 The test procedure is as follows:

- a) Make a measurement for each of the following recommended volume fractions of propane calibration gas: 2000 ppm vol and 10000 ppm vol;
- b) Calculate the absolute error of the Instruments for each of these two volume fractions of propane calibration gas;

To this end, the true value is determined as follows:

$$I_{\text{true}} = C \times \text{PEF}$$

Where,

C = True value of the volume concentration of propane; and

PEF = Value of the propane/hexane equivalency factor given by the manufacturer

- c) Make a measurement for each of the following recommended fractions of hexane calibration gas (1000 ppm vol and 5000 ppm vol);
- d) Calculate the absolute error of the instrument for each of these two volume fractions of hexane; and
- e) For each of the two volume fractions, calculate the difference between the error obtained with propane and that obtained with hexane.

4.6.23.2 The difference between the errors shall not exceed (according to the case 4.2.9) the applicable maximum permissible intrinsic error or half of the applicable maximum permissible intrinsic error.

NOTE — It is assumed that the error of the instruments is constant both near 100 ppm vol and near 1000 ppm vol.

CAUTIONARY NOTE: Because of its low vapour pressure, Hexane can condense at ordinary temperatures of shipment, storage and use. Such condensation would invalidate the certified gas mixture concentration. Therefore, extreme care shall be taken at all times during shipment, storage and use to ensure that Hexane cylinders are maintained sufficiently above the condensation temperature for the specified gas volume fraction at the cylinder pressure.

4.6.24 Engine Speed Measurement System

The linearity of engine speed measurement shall be checked at minimum 4 points, which shall include at least one point, which is more than 80% of the required full-scale range. The linearity shall be checked using engine speed measurement system with the accuracy of at least ± 3 rpm.

4.6.25 Measurement Test Data Acquisition and Electronic Upload

- a) The instrument shall be equipped with suitable means to acquire in use vehicle emission test data of each measurement test performed in the field;
- b) The instrument shall be equipped with a facility to electronically upload measured field test data to NIC web application through an API; and
- c) The data parameters to be electronically uploaded to the NIC web application shall include the following in the prescribed sequence.

4.6.25.1 Data Format Requirements for 4 Gas Analyser

Sl. No.	Parameter	Field Type	Field Size	Example
(i)	CO	Numeric	5	1.23
(ii)	HC	Numeric	5	6666
(iii)	CO ₂	Numeric	5	12.12
(iv)	O ₂	Numeric	5	12.12
(v)	Engine speed	Numeric	5	6666
(vi)	Lambda CO	Numeric	5	1.23
(vii)	Lambda	Numeric	5	0.987
(viii)	Date of test	Text	12	DD-MM-YYYY
(ix)	Time of test	Text	8	HH:MM

4.6.25.2 Application Program Interface (API)

Manufacturer / supplier of PUC test equipment shall develop an 'Application Program Interface' (API) for the 4 gas analyzer. The API shall communicate with the 4 gas analyzer on one end and with NIC web application on the other end.

The API shall meet the following requirements:

- a) The API shall be web enabled / web compatible;
- b) Preferred web browser for the API shall be either Mozilla Firefox or Google Chrome;
- c) It shall be possible to call the API through an URL. Typical URL may be as below. However, the PUC test equipment manufacturer / supplier shall finalize URL.
 - 1) http://localhost:xxxxx/api/PUC_Test_Equipment_Manufacturer/Model (For default value return)
 - 2) http://localhost:xxxxx/api/PUC_Test_Equipment_Manufacturer/Model (For actual test);

- and
d) The output of the API shall be in “JSON” format

4.6.25.3 Return Parameter

Sl. no.	Parameter
(i)	<PUC Test Equipment Manufacturer / Model_tController.puc_data>
(ii)	<CO>1</CO>
(iii)	<HC>2</HC>
(iv)	<CO ₂ >3</CO ₂ >
(v)	<O ₂ >4</O ₂ >
(vi)	<RPM>5</RPM>
(vii)	<Lambda_CO>6</Lambda_CO>
(viii)	<Lambda>7</Lambda>
(ix)	<Date>01-01-2018</Date>
(x)	<Time>12:12</Time>
(xi)	<Reserve>8</Reserve>
(xii)	<Status>OK</Status>
(xiii)	</PUC Test Equipment Manufacturer Model_tController.puc_data>

4.7 Metrological Controls

4.7.1 Initial Verification

4.7.1.1 General requirements

A new instrument shall undergo initial verification only after type approval/certification. The verification shall be carried out using suitable testing means and certified calibration gases.

4.7.1.2 Inspection and tests

4.7.1.2.1 Initial verification of an instrument includes a visual inspection to determine conformance with the approved type approval/certification.

4.7.1.2.2 After adjusting an instrument according to the routine adjustment procedure described in the manufacturer’s operating instructions, tests to determine its errors shall be carried out under rated operating conditions at several values over the measuring range. The tests shall be performed using gas mixtures of at least three different volume fractions within the nominal ranges of the measurands as listed below:

Gas	Concentrations Nominal range
CO	0.5 % vol to 5 % vol

CO ₂	4 % vol to 16 % vol
HC	100 ppm vol to 10000 ppm vol as <i>n</i> -hexane

For all classes Oxygen channel should be tested for zero reading and span reading using a calibration gas without oxygen (only CO and/or CO₂ and/or HC in N₂) and a calibration gas containing 20.9 % vol O₂.

The calibration gases shall be introduced at the sample probe inlet at ambient pressure (to within 750 Pa). The errors observed shall be within the limits of the maximum permissible error of 4.2.4.2 on initial verification for each measurement.

4.7.2 Subsequent Verification

Clear and unambiguous instructions about requirements and intervals for subsequent verification and advice about routine testing shall be provided in the operating manuals and all other related documents for example, Service Manual, etc.

5 TECHNICAL SPECIFICATIONS AND TEST PROCEDURE FOR SMOKE METERS

5.1 Smoke Meter Specifications

5.1.1 Type of Tests

Smoke meter shall be suitable for conducting free acceleration test on different types of diesel vehicles as per CMVR 115 2(C) and 115(4). The smoke meter shall be labelled accordingly.

The smoke meter shall have probes of sufficient length (minimum 2 m) to facilitate easy attachment to the tailpipe of vehicles. According to the test procedure for free acceleration tests, the ratio of cross-sectional area of the probe to that of exhaust pipe shall not be less than 0.05. Considering the exhaust pipe diameter of 10 cm, the equipment shall be supplied with at least one probe of internal diameter not less than 2.25 cm.

5.1.2 Display

The smoke meter shall indicate light absorption coefficient 'K' directly. The instrument shall have peak hold facility to display / print the maximum smoke reading obtained during free acceleration test.

5.1.3 Oil Temperature Measurement System

The oil temperature measurement system shall have measurement range of at least 0 to 150°C. The oil temperature measurement shall have resolution of 1°C with accuracy of at least ±3°C. Temperature probe arrangement shall be such that it can be used for all types of diesel vehicles with different oil dipstick lengths. The temperature probe shall have a sleeve for fixing in to the oil probe assembly.

Alternately, the engine oil temperature may be measured through the On-board diagnostic (OBD) port of the vehicle under test and electronically communicated to the smoke meter.

5.1.4 Engine Speed Measurement System

The engine speed measurement shall be carried out with an easily attachable speed sensor. The speed measurement range shall be minimum from 200 to 6000 rpm with the resolution of 10 rpm. The accuracy of speed measurement shall be ± 20 rpm or ± 2% of the reading, whichever is greater, and the rpm display shall be updated at least at 0.5 s time interval.

Alternately, the engine speed may be measured through the On-board diagnostic (OBD) port

of the vehicle under test and electronically communicated to the smoke meter.

5.1.5 The instrument shall be equipped with an RS 232 / USB / TCP/IP Ethernet / Wireless interface permitting coupling to any peripheral devices or instruments. An interface shall not allow the metrological functions of the instruments or their measurement data to be inadmissibly influenced by the peripheral devices, by other interconnected instruments, or by disturbances acting on the interface. Functions that are performed or initiated via an interface shall meet the relevant requirements and conditions of the clause “Technical requirements”.

If the instrument are connected to a data printer / PC / any other peripheral device, through wired or wireless interface then the data transmission from the instrument to such peripheral device shall be designed so that the results cannot be falsified. It shall not be possible to measure and or print out a document or test report or test certificate for legal purposes, if the instrument checking facility(s) detect(s) a significant fault or a malfunction in the Instrument.

5.1.6 Heating

The condensation in the smoke chamber shall be avoided. If necessary, instrument shall have heating facility for the same.

5.1.7 Markings

The instruments shall be fitted with a permanent and easily readable label or labels giving the following information in English language:

- a) model number;
- b) serial number;
- c) name and address of the manufacturer;
- d) year and month of manufacture; and
- e) operating voltage range.

5.1.8 Scale

The scale shall be zero to at least 6 m^{-1} for light absorption coefficient.

5.1.9 Resolution

The smoke meter shall have a resolution of at least 0.1 m^{-1} between range 0 to 4 m^{-1} .

5.1.10 Calibration

The smoke meter shall have facility to adjust zero reading when the smoke meter is filled with clean air. Each smoke meter shall be supplied with a Neutral density filter (NDF) of known value to accuracy of $\pm 0.05 \text{ m}^{-1}$ light absorption coefficient (along with the calibration certificate) in the region of 1.5 to 2.5 m^{-1} . It shall be possible to calibrate the smoke meter easily in the field using this filter.

5.1.11 Linearity

The linearity of the smoke meter shall be within $\pm 0.1 \text{ m}^{-1}$.

5.1.12 Drift

The instrument zero drift and span drift, with neutral density filter having value between 1.5 to 2.5 m^{-1} , shall not exceed $\pm 0.1 \text{ m}^{-1}$ for four hours after warming up.

5.1.13 Repeatability

The repeatability of the instrument shall not exceed $\pm 0.1 \text{ m}^{-1}$ during five successive calibration tests with the Neutral Density Filter having value between 1.5 to 2.5 m^{-1} .

5.1.14 Light Source

The light source shall be an incandescent lamp with a colour temperature in the range 2800 to 3250 K or a green Light Emitting Diode (LED) with a spectral peak between 550 and 570 nm .

The smoke meter shall be supplied with spectral response characteristics of the light source received from a reputed organization.

5.1.15 *Light Detector*

It shall be a photo cell or photo diode (with filter if necessary). Any other equivalent device can be used if the equivalence is established by the manufacturer. In the case of an incandescent light source, the detector shall have a peak spectral response in the range 550 to 570 nm and shall have gradual reduction in response to value less than 4% of the peak response value below 430 nm and above 680 nm. The smoke meter shall be supplied with spectral response characteristics of the detector received from a reputed organization.

5.1.16 *Response Time*

5.1.16.1 *Physical Response Time*

This is due to physical phenomena in the smoke chamber and is the time taken from the start of the gas entering the chamber to complete filling of the smoke chamber. It shall not exceed 0.4 seconds.

5.1.16.2 *Electrical Response Time*

The response time of electrical measuring circuit, being the time necessary for the indicating dial to reach 90% of full scale deflection on insertion of a screen fully obscuring the photoelectric cell, shall be maximum 1.1 s.

The damping of the electrical measuring circuit shall be such that the initial over-swing beyond the final steady reading after any momentary variation in input (for example, calibration screen) does not exceed 0.1 m^{-1} with neutral density filter having value between 1.5 to 2.5 m^{-1} .

5.1.17 *Soiling of Light Source and Receiver*

The smoke meter shall be capable of being used for a period sufficient to take measurements without soiling of the light source and receiver. This is considered satisfactory if the overall drift of the instrument is less than 0.2 m^{-1} for over 1 h when used on diesel engine / vehicle producing smoke of light absorption coefficient between 2 to 4 m^{-1} .

5.1.18 *Warm Up Time*

Unless otherwise indicated on the meter, the smoke meter shall be stabilized for operation within half an hour after power 'ON'.

5.1.19 *Environmental Conditions*

5.1.19.1 The smoke meter shall withstand following environmental conditions:

Supply voltage variation of $230 \text{ V} \pm 10\%$. The instruments powered by battery shall have the battery condition indication and shall withstand indicated voltage variation.

5.1.19.2 Temperature range of 278 K to 323 K.

5.1.19.3 *Vibrations*

The meter shall withstand the vibrations encountered in the normal garage environment. The test agency may decide suitable method to test this. The recommended levels as per IS/IEC 60068-2-6, are:

Frequency : 5 to 9 Hz Amplitude $\pm 3 \text{ mm}$, 9 to 150 Hz Amplitude $\pm 1 \text{ g}$
Duration : 1 hour
Sweep rate : 1 octave per minute

5.1.19.4 *Drop Test*

The meter shall withstand drop test of 2 falls on each edge from a height of 50 mm. Any other electric or electronic components, which are carried by operator during operation (for example

Remote control unit) shall withstand a drop test of 2 falls from a height of 0.5 meter.

5.1.20 *Electromagnetic Isolation*

The smoke meter is required to be capable of providing unaffected operation in electromagnetic radiation or conductive interference produced by vehicle ignition systems and building electrical systems.

5.1.21 *Correlation to Reference Smoke Meter*

The meter shall be correctable for the free acceleration test with the reference standard meter meeting UN regulation 24 requirements.

5.1.22 *Documentation*

When the smoke meter is submitted for testing, the smoke meter shall be accompanied with following information in English:

- a) All technical specifications of the smoke meter;
- b) Description of the general principle of measurement;
- c) List of essential components with their characteristics;
- d) Description of the essential components with drawings and diagrams that are necessary for testing and maintenance;
- e) General information on the software required for a microprocessor equipped measuring instrument including API software, NIC web application URL, test procedure, etc.;
- f) The operating instructions that shall be provided to the user;
- g) Details of how calculations are performed;
- h) A fully documented calibration procedure and a set of calibration filters;
- j) A photograph of the instrument; and
- k) The operating manual supplied with every smoke meter shall include the description of the test procedure described in 7.

5.2 Smoke Meter Test Procedure

5.2.1 *Physical Check*

It shall consist of checking of following:

- a) Suitability and label on the instrument for the intended use;
- b) Identification of the instrument consisting of model, serial number, name and address of the manufacturer, electrical power requirement, year and month of manufacture and operating voltage range specified in English language;
- c) Scale, resolution, display;
- d) Peak hold facility;
- e) Heating facility;
- f) Calibration facility;
- g) Printout specifications;
- h) Oil temperature sensor probe;
- j) Engine speed sensor clamp / attachment;
- k) Documentation; and
- m) Checking of probe

5.2.2 *Linearity*

5.2.2.1 *Smoke measurement*

The linearity of smoke measurement shall be checked at minimum 4 points (1 point to include a full scale point, in case meter full scale corresponds to the total light cut-off) including the zero point. This will be checked by three different neutral density filters of known value within $\pm 0.05 \text{ m}^{-1}$ in the specified range given below, supplied by the smoke meter manufacturer or

his representative along with calibration certificate from an accredited agency. The neutral density filter shall have flat response (preferably within $\pm 2\%$ tolerance in absolute value) between the wavelength range 430 to 680 nm and the response at spot frequency between 550 to 570 nm as recommended by the manufacturer will be considered for linearity test. The test agency may decide to test the accuracy of the filter prior to the test.

One filter having $K \leq 1 \text{ m}^{-1}$
One filter having K between 1.5 and 2.5 m^{-1}
One filter having $K \geq 3 \text{ m}^{-1}$

5.2.2.2 Engine speed measurement

The linearity of engine speed measurement shall be checked at minimum 4 points, which shall include at least one point, which is more than 80% of the required full scale range. The linearity shall be checked using engine speed measurement system with the accuracy of at least ± 3 rpm. The accuracy of speed measurement shall be ± 20 rpm or $\pm 2\%$ of the reading, whichever is greater.

Alternately, the engine speed may be measured through the On-board diagnostic (OBD) port of the vehicle under test and electronically communicated to the smoke meter.

5.2.2.3 Oil temperature measurement

The linearity of oil temperature measurement shall be checked at minimum 4 points, uniformly distributed over the full-scale range. The linearity shall be checked using temperature measurement system, preferably oil bath, with the accuracy of at least $\pm 0.5^\circ\text{C}$. The accuracy of the oil temperature measurement system shall be $\pm 3^\circ\text{C}$ of the reading.

Alternately, the engine oil temperature may be measured through the On-board diagnostic (OBD) port of the vehicle under test and electronically communicated to the smoke meter.

5.2.3 Drift

Both zero drift and span drift shall be checked for four hours with readings taken at every half an hour interval. Span drift shall be tested using neutral density filter having light absorption coefficient in the range 1.5 to 2.5 m^{-1} .

5.2.4 Repeatability

Repeatability shall be checked five times with the neutral density filter having light absorption coefficient in the range 1.5 to 2.5 m^{-1} .

5.2.5 Light Source

Check that with voltage variation specified in **5.1.19.1**, the colour temperature of the light source is between 2800 to 3250 K or verify that a green light emitting diode (LED) is used by checking the spectral peak between 550 and 570 nm.

5.2.6 Light Detector

Check that the combined receiver and filter characteristics have a maximum response in the range 550 to 570 nm, and less than 4% of that maximum response below 430 nm and above 680 nm, or verify that a green LED is used in conjunction with a photodiode, since the wavelength is set by the green light emitting diode (LED). It is not necessary to check the photodiode when used with a green light emitting diode (LED).

5.2.7 Response Time

5.2.7.1 Physical response time

Smoke meter manufacturer or its representative shall provide sufficient data and sample calculations to verify the physical response time.

5.2.7.2 Electrical response time

Smoke meter manufacturer or representative shall provide the sufficient supporting documents to meet the specifications. Damping of the electrical measuring circuit shall be checked by inserting the neutral density filter having value between 1.5 to 2.5 m^{-1} .

5.2.8 Soiling of Light Source and Receiver

After calibration, the meter will be continuously used for 1 h on an engine / vehicle producing smoke of light absorption coefficient between 2 to 4 m^{-1} . The zero reading after the test shall be checked and compared. The difference shall not be more than 0.2 m^{-1} .

5.2.9 Environmental Testing

5.2.9.1 Voltage variation

Smoke meter zero and span (with a neutral density filter having value between 1.5 and 2.5 m^{-1}) reading shall be checked at 230V \pm 10% value. In case of the instruments powered by battery, voltage shall be varied within the indicated voltage range. The difference in the reading shall be less than 0.1 m^{-1} .

5.2.9.2 Temperature

The smoke meter shall be maintained at 278 K and 323 K temperature. Span reading with neutral density filter having value between 1.5 to 2.5 m^{-1} at both these temperatures shall be within \pm 0.1 m^{-1} from the reading obtained at the room temperature of 303 \pm 2 K.

5.2.9.3 Vibration

The smoke meter shall be checked for the vibrations as per **5.1.19.3**, preferably with electrical power 'ON' condition. A span measurement with neutral density filter having value between 1.5 to 2.5 m^{-1} , shall be taken before and after the test and the difference in the reading shall be within \pm 0.1 m^{-1} . In case the electrical power of the instrument is switched 'OFF', the readings shall be taken after warming up and initial calibration of the instrument.

5.2.9.4 Drop Test

5.2.9.4.1 Part-I

The meter components (except those which are wall mounted) shall be positioned in their normal orientation of use on a rigid surface. They shall be tilted on one bottom edge and then allowed to fall freely on to the test surface.

All covers shall be fitted properly. They shall be subjected to two falls on each edge from a height of 50 mm, measured from the elevated edge of the unit to the test surface. A span measurement with neutral density filter having value between 1.5 to 2.5 m^{-1} , shall be taken before and after the test and the difference in the reading shall be within \pm 0.1 m^{-1} . As the electrical power of the instrument is switched 'OFF', the readings shall be taken after warming up and initial calibration of the instrument.

5.2.9.4.2 Part-II

This part applies only to those parts of the meter which contain electrical or electronic components and which are carried by the operator during normal use, for example any part which attaches to the vehicle exhaust or a remote-control unit etc. The test consists of subjecting the relevant component to two falls from a height of 0.5 m onto a smooth hard rigid surface of either concrete or steel. A span measurement with neutral density filter having value between 1.5 to 2.5 m^{-1} , shall be taken before and after the test and the difference in the reading shall be within \pm 0.1 m^{-1} . As the electrical power of the instrument is switched 'OFF', the readings shall be taken after warming up and initial calibration of the instrument.

5.2.10 Electromagnetic Isolation

This test shall be conducted in the vicinity of minimum five number of SI engine vehicles operating within approximate distance of 3 to 5 m from the equipment. The vehicles shall not be fitted with ignition suppression devices. A span measurement with neutral density filter having the value between 1.5 to 2.5 m^{-1} shall not vary by more than 0.1 m^{-1} after switching on the SI engine vehicles.

5.2.11 Correlation Tests

5.2.11.1 Free acceleration test

The test shall be carried out as per 7.2.1.2 on at least five different diesel vehicles / engines as follows:

- a) One engine used for car / jeep application; and
- b) Four different engines used for LCV / HCV application.

The correlation tests shall be performed using either engines or complete vehicles. If the test is carried out on an engine mounted on test bench, the engine shall be decoupled from the dynamometer. If the test is carried out on a vehicle, the gear change control shall be set in the neutral position and the drive between engine and gearbox engaged. The free acceleration test shall be carried out using certified/type-approved meter.

A sequence of four free acceleration tests as shall be conducted with smoke meters as given below:

- Test 1** : With reference smoke meter
- Test 2** : Subject meter installed on its own in the vehicle tailpipe and calibrated according to manufacturer's instructions using a neutral density filter.
- Test 3** : as per Test 2
- Test 4** : as per Test 1

Based on the mean of valid three readings in each test:

- a) A test sequence is valid only if 'K' value of test does not vary from test 1 by more than 0.3 m^{-1} ;
- b) The percentage difference between the mean of the test 1 and 4 and the mean of test 2 and 3, for five vehicles, shall be less than figures given in the table below;

Mean value of Test 1 and 4 K (m^{-1})	% Difference allowed	
	(3 Vehicles)	(2 Vehicles)
≤ 1	5	10
$> 1, \leq 2$	7.5 or 0.1 m^{-1} Whichever is higher	15
$> 2, \leq 3$	10	20
> 3	12.5	25

- c) The result of test 2 and 3 must lie within $\pm 10\%$ of the mean of the two tests; and

- d) In case correlation test does not meet the tolerances specified above in only one of the vehicles / engines, additional two correlation tests each consisting of five tests as mentioned above shall be carried out on different vehicles / engines (vehicles/engines other than used in the first series of correlation tests). The meter can be considered satisfactory if it meets these additional correlation tests.

5.2.12 Measurement Test Data Acquisition and Electronic Upload

- a) The instrument shall be equipped with suitable means to acquire in use vehicle emission test data of each measurement test performed in the field; and
b) The instrument shall be equipped with a facility to electronically upload measured field test data to NIC web application through an API.

The data parameters to be electronically uploaded to the NIC web application shall include the following in the prescribed sequence:

5.2.12.1 Data format requirements for smoke meter

Sl. No.	Parameter	Field Type	Field Size	Example
(i)	Average engine speed in flushing cycle	Numeric	5	6666
(ii)	Measurement cycle 1, opacity (K value)	Numeric	4	1.23
(iii)	Measurement cycle 1, max engine speed	Numeric	5	6666
(iv)	Measurement cycle 1, oil temperature	Numeric	3	60
(v)	Measurement cycle 2, opacity (K value)	Numeric	4	1.23
(vi)	Measurement cycle 2, max engine speed	Numeric	5	6666
(vii)	Measurement cycle 2, oil temperature	Numeric	3	60
(viii)	Measurement cycle 3, opacity (K value)	Numeric	4	1.23
(ix)	Measurement cycle 3, max engine speed	Numeric	5	6666
(x)	Measurement cycle 3, oil temperature	Numeric	3	60
(xi)	Average opacity of three measurement cycle reading	Numeric	4	1.23
(xii)	Date of test	Text	12	DD-MM-YYYY
(xiii)	Time of test	Text	8	HH:MM

5.2.12.2 Application program interface (API)

Manufacturer / supplier of PUC test equipment shall develop an ‘Application Program Interface’ (API) for its certified/type approved PUC test equipment model. The API shall communicate with the PUC test equipment on one end and with NIC web application on the other end. The API shall follow the following guidelines / meet the following requirements:

- a) The API shall be web enabled / web compatible;
b) Preferred web browser for the API shall be either Mozilla Firefox or Google Chrome;
c) It shall be possible to call the API through an URL. Typical URL may be as below. However, the PUC test equipment manufacturer / supplier shall finalise URL; and <http://localhost:xxxxx/api/PUC> Test Equipment Manufacturer/Model t (For default value return)

<http://localhost:xxxxx/api/PUC> Test Equipment Manufacturer/Model (For actual test)

d) The output of the API shall be in 'JSON' format.

5.2.12.3 Return parameter

Sl. No.	Parameter
(i)	<PUC Test Equipment Manufacturer /
(ii)	Model_tController.puc_data>
(iii)	<Flush_Cyl>#PT;100;5000;60</Flush_Cyl>
(iv)	<Status>OK</Status>
(v)	<Test1>TR01; 0.63;800;5000;60</Test1>
(vi)	<Test2>TR02; 0.63;800;5000;60</Test2>
(vii)	<Test3>TR03; 0.63;800;5000;60</Test3>
(viii)	<Test_AVG>#TA;0.63</Test_AVG>
(ix)	<Date>01-01-2018</Date>
(x)	<Time>12:12</Time>
(xi)	<Test_Status>#TS0</Test_Status>
(xii)	Model_tController.puc_data>
(xiii)	String Description
(xiv)	<Flush_Cyl>#PT;100;5000;60</Flush_Cyl> Flush cycle, Idle RPM,Max RPM, Oil Temp
(xv)	<Test1>TR01;0.63;800;5000;60</Test1> Free acceleration test 1, K Value, Idle RPM, Max RPM,Oil Temp
(xvi)	<Test2>TR02;0.63;800;5000;60</Test2> Free acceleration test 2, K Value, Idle RPM, Max RPM, Oil Temp
xvii)	<Test3>TR03;0.63;800;5000;60</Test3> Free acceleration test 3, K Value, Idle RPM, Max RPM, Oil Temp
xviii)	<Test_AVG>#TA; 0.63</Test_AVG> Test Average K Value
(xix)	<Test_Status>#TS0</Test_Status> #TS0 – Test successful by instrument
(xx)	#TS1 – Test fail by instrument
(xxi)	#TS2 – Test abort by instrument

6 MEASUREMENT OF CARBON MONOXIDE AND HYDRO CARBON EMISSIONS AT IDLING AND RAISED IDLE FOR IN-SERVICE VEHICLE FITTED WITH SI ENGINES

It specifies standard and test procedure for the determination of the volumetric concentration of exhaust carbon monoxide (CO) and hydrocarbon (HC) emissions from road vehicles equipped with spark ignition engines running at idle speed and raised idle. It applies to the emissions of carbon monoxide and hydro carbon at idle speed and raised idle from in-service vehicles fitted with spark ignition engines as referred in CMVR-115 (2) (a), and for issue of "Pollution under control certificate" to be issued by authorized agencies.

6.1 Test Procedure

6.1.1 Instrument

6.1.1.1 The instrument used for the measurement of CO and HC shall be a certified/type approved instrument and meet the requirements specified in this standards. The tachometer to

measure engine idling speed shall have an accuracy of ± 50 rpm.

For measurement of idling CO and HC emissions of in-use 2, 3 and 4 wheelers (other than Bharat Stage II and above compliant) vehicles, certified/type approved 2 Gas analyzer shall be used.

For measurement of idling CO and HC emissions of in-use 4 wheeler vehicles (Bharat Stage II and above compliant), certified/type approved 4 Gas analyser shall be used.

6.1.1.2 The instrument shall be prepared, used and maintained following the directions given in the instrument manufacturer's operation manual, and it shall be serviced and calibrated at such intervals as to ensure accuracy.

6.1.1.3 The electronic calibration shall be carried out at least once after switching on the instrument and thereafter a maximum time period of 4 h. The span calibration using gas bottle shall be carried out at least once in four months and whenever instrument is moved to a different place. The total record of calibration shall be maintained and if it is observed during calibration that the calibration is shifted more than the accuracy, the calibration period shall be suitably reduced. The calibration shall be performed well away from the exhaust of motor vehicles whose engines are running.

6.1.1.4 If the sample handling system is not integral with the analyzer, the effectiveness of the condensate traps and all connections of the gas sampling system shall be checked. Following shall be checked:

- i) Filters are clean;
- ii) Filter holders are fitted with their gaskets; and
- iii) These are in good conditions.

6.1.1.5 If the instrument is not self-compensated for non-standard conditions of altitude and ambient temperature or not equipped within a manually controlled system of compensation, the span calibration shall be performed with calibration gas.

6.1.1.6 It shall be ensured that the sample handling line and probe are free from contaminants and condensates.

6.1.2 *Vehicle Preparation*

6.1.2.1 It shall be checked that the road vehicle exhaust system is leak proof and that the manual choke control has been returned to the rest position.

6.1.2.2 It shall be checked that the gas sampling probe can be inserted into the exhaust pipe to a depth of at least 300 mm. If this proves impossible owing to the exhaust pipe configuration, a suitable extension to the exhaust pipe(s), making sure that the connection is leak proof, shall be provided.

6.1.2.3 The vehicle shall have attained normal thermal conditions as defined in 3.35, immediately prior to the measurement.

6.1.2.4 The vehicle idling speed shall be checked and set as per 3.34, as prescribed by the manufacturer, with all the accessories switched off.

6.1.3 *Measurement*

6.1.3.1 Immediately preceding the measurement, the engine is to be accelerated to a moderate speed with no load, maintained for at least 15 s, then returned to idle speed as set in 6.1.2.4.

6.1.3.2 While the engine idles, the sampling probe shall be inserted into the exhaust pipe to a depth not less than 300 mm.

6.1.3.3 After the engine speed stabilises, the reading shall be taken.

6.1.3.4 The value of CO and HC concentration reading shall be recorded.

6.1.3.5 In cases where gadgets or devices are incorporated in the exhaust system, for dilution of the exhaust, both CO and CO₂ shall be measured using an instrument having facility to measure both CO and CO₂. If the total of the measured values of CO and CO₂ (T_{CO} and T_{CO₂}) concentration exceed 15% for four stroke engines and 10% for two stroke engines, the measured value of CO shall be taken as carbon monoxide emissions from the vehicle. If it does not, the corrected value (T corrected) shall be taken, as given below:

$$\mathbf{T\ corrected = T\ CO \times 15 / (T\ CO + T\ CO_2)\ \mathbf{For\ 4-stroke\ engines}}$$

$$\mathbf{T\ corrected = T\ CO \times 10 / (T\ CO + T\ CO_2)\ \mathbf{For\ 2-stroke\ engines}}$$

6.1.4 Multiple exhaust outlets shall be connected to a manifold arrangement terminating in a single outlet. If a suitable adopter is not available, the arithmetic average of the concentrations from the multiple pipes may be used.

6.1.5 If the measurement is to be repeated, the entire procedure of 6.1 shall be repeated.

6.1.6 For the purpose of PUC (Pollution Under Control) certification, if the idling CO and/or HC are not within limits, the testing shall be discontinued and the vehicle owner shall be advised to resubmit the vehicle after repair / service.

6.2 Raised Idle Test Procedure

This test shall immediately follow the idle emission measurement test. For raised Idle emission measurement, maintain the engine speed (in revolution per minute) at 2500 ± 200, fuel system control (choke) in the rest position, transmission in neutral and clutch engaged in the case of vehicles with manual or semi-automatic transmission or with selector in park or neutral position when an automatic transmission is installed, as recommended by the manufacturer. Sampling probe shall be inserted into the exhaust pipe to a depth not less than 300 mm and the reading shall be taken after the engine speed stabilises at 2500 ± 200 rpm.

The value of CO concentration with lambda reading shall be recorded.

6.3 Test Limits

Table-1
(Petrol/Compressed Natural Gas/Liquefied Petroleum Gas Driven Vehicles
Manufactured as per [Bharat Stage-IV or Bharat Stage-VI] Norms)

Sl No.	Type of vehicle	Idle emission limits		High idle emission limits (RPM-2500±200)	
		CO%	HC (n hexane equivalent) ppm	CO%	λ
(1)	(2)	(3)	(4)	(5)	(6)
1.	Compressed Natural Gas/Liquefied Petroleum Gas driven 4-wheelers manufactured as per Bharat Stage-IV or Bharat Stage-VI norms.	0.3	200	—	1 ± 0.03 or as declared by the manufacturer.

2.	Petrol driven four wheelers manufactured as per Bharat Stage-IV or Bharat Stage-VI norms.	0.3	200	0.2	
3.	Compressed Natural Gas/Liquefied Petroleum Gas driven two/three wheelers manufactured as per Bharat Stage-VI norms.	0.5	500	—	
4.	Petrol driven two/three wheelers manufactured as per Bharat Stage-VI norms.	0.5	500	0.3	

Table-2
Petrol/CNG/LPG Driven Vehicles

SI No.	VECHILE TYPE	CO%	*HC(n-hexane equivalent)ppm
1	Two Wheelers (2/4- Stroke) (Vehicles manufactured on and before 31 st March, 2000)	4.5	9 000
2	Two Wheelers(2-Stroke) (vehicles manufactured between31 st march 2000 and 31 st march 2010)	3.5	6 000
3	Two Wheelers (4-Stroke) (vehicles manufactured between31 st march,2000 and 31 st March, 2010)	3.5	4 500
4	Two Wheelers (2-Stroke) (vehicles manufactured after 31 st March, 2010)	3.0	4 000
5	Two Wheelers (4-Stroke) (vehicles manufactured after 31 st March, 2010)	3.0	3 000
6	Three Wheelers (2/4-Stroke) (vehicles manufactured on and before 31 st march,2000)	4.5	9 000
7	Three Wheelers (2-Stroke)) (vehicles manufactured after31 st March, 2000)	3.5	6 000
8	Three Wheelers (4-Stroke)) (vehicles manufactured after31 st March, 2000)	3.5	4 500
9	Four Wheelers manufactured as per pre-Bharat Stage II emission norms	3.0	1,500
10	Four Wheelers manufactured as per pre-Bharat Stage II or Bharat Stage III Emission norms	0.5	750

7 MEASUREMENT OF SMOKE LEVELS BY FREE ACCELERATION FOR IN-

SERVICE VEHICLES FITTED WITH DIESEL ENGINES

It specifies standard and test procedure for the determination of smoke levels by free acceleration from road vehicles equipped with compression ignition engines. It applies to the emissions of visible pollutants from in-service compression ignition (diesel) engine vehicles, when subjected to a free acceleration test as referred in CMVR-115 (2)(b) and for issue of "Pollution under control certificate" to be issued by the authorized agencies.

7.1 Test Procedure

7.1.1 Test Instrument

7.1.1.1 The Smoke Meter — The Instrument used for the measurement of smoke. It should be a certified/type approved instrument and meet the requirement of this standard.

7.1.1.2 The instrument should be prepared, used and maintained following the directions given in the instrument manufacturer's operation manual and it should be serviced and calibrated at such intervals as to ensure accuracy.

7.1.2 Sampling Smoke Meter

7.1.2.1 Installation for tests under free acceleration

7.1.2.1.1 The ratio of cross sectional area of the probe to that of the exhaust pipe shall not be less than 0.05.

7.1.2.1.2 The probe shall be a tube with an open end facing forward in the axis of exhaust pipe or of the extension pipe, if one is required. It shall be situated in a section where the distribution of smoke is approximately uniform. To achieve this, the probe shall be placed as far downstream in the exhaust pipe as possible or if necessary in an extension pipe so that, if D is the diameter of exhaust pipe at the opening, the end of probe is situated in a straight portion at least $6D$ in length upstream of the sampling point and $3D$ in length downstream. If an extension pipe is used, no air shall be allowed to enter the joint.

7.1.2.1.3 The sampling system shall be such that at all engine speeds, pressure of the sample at the smoke meter is within the limits specified. This may be checked by noting the sample pressure at engine idling and maximum no load speeds. Depending on the characteristics of the smoke meter, control of sample pressure can be achieved by a fixed restriction or butterfly valve in the exhaust pipe or extension pipe. Whichever method is used, the back pressure measured in the exhaust pipe at the opening of the probe shall not exceed 75 mm (water gauge).

7.1.2.1.4 The pipes connecting the smoke meter shall also be as short as possible. The pipe shall be inclined upwards from the sampling point to the smoke meter and sharp bends where soot might accumulate shall be avoided. A bypass valve may be provided upstream of smoke meter to isolate it from the exhaust gas flow when no measurement is being made.

7.1.2.1.5 The temperature probe for the measurement of oil temperature shall be inserted in place of oil dipstick.

Alternately, the engine oil temperature may be measured through the On-board diagnostic (OBD) port of the vehicle under test and electronically communicated to the smoke meter.

7.1.2.1.6 The engine speed measurement sensor shall be appropriately installed on to the engine of the vehicle.

Alternately, the engine speed may be measured through the On-board diagnostic (OBD) port of the vehicle under test and electronically communicated to the smoke meter.

7.1.3 Vehicle Inspection

7.1.3.1 The exhaust device shall not have any orifice through which the gases emitted by the engine might be diluted.

7.1.3.2 In cases where an engine has several exhaust outlets, these shall be connected to a single outlet in which opacity measurement shall be made. If it is not possible, to combine all exhaust outlets in one, the smoke shall be measured in each and an arithmetical mean of the values shall be recorded at each outlet. The test shall be taken as valid only if the extreme values measured do not differ by more than 0.15 m^{-1} .

7.1.3.3 The engine shall be in normal working condition prescribed by the manufacturer.

7.2 Measurement Procedure

7.2.1 Free Acceleration Test

7.2.1.1 The combustion chamber shall not have been cooled or fouled by a prolonged period of idling preceding the test.

7.2.1.2 The vehicle gear change control shall be set in the neutral position and the drive between engine and gearbox engaged. With the engine idling, the accelerator control shall be operated quickly, but not violently, so as to obtain maximum delivery from the injection pump. This position shall be maintained until maximum engine speed is reached and the governor comes into action. As soon as this speed is reached the accelerator shall be released until the engine resumes its idling speed and the smoke meter reverts to the corresponding conditions. Typically, the maximum time for acceleration shall be 5s and for the stabilization at maximum no load speed shall be 2s. The time duration between the two free accelerations shall be between 5 to 20 s.

- a) Three times flushing by free acceleration to be undertaken with or without the sampling probe in the vehicle exhaust, and average maximum rpm of the three flushings to be recorded;
- b) Thereafter, with sample probe inserted in vehicle exhaust during each free acceleration, maximum no-load rpm reached shall be within the bandwidth of ± 500 rpm of the average value in respect of 3 wheeled vehicles and ± 300 rpm of the average value for all other categories of vehicles;
- c) The free acceleration test, mentioned in **7.2.1.2(b)**, shall be repeated minimum three times;
- d) The smoke density to be recorded shall be arithmetic mean of these three readings; and
- e) In case the smoke density recorded is not within the limits, then, the test may be repeated with engine oil temperature measured by a probe in the oil level dipstick tube to be at least 60°C .

Provided that the above test shall not be carried out if the On-board diagnostic (OBD) malfunction indicator lamp (MIL-DTC) of BS-IV and onward vehicles is switched on, in such cases, the vehicle shall be re-submitted for the above test after repair or servicing.

Zero drift shall be checked after the test and if drift is greater than 0.2 m^{-1} this test shall be considered as invalid and repeated. If the drift is 0.2 m^{-1} or less and positive, it shall be subtracted from the mean of the last valid reading.

7.3 Test Limits

Table-3
(Diesel Vehicles)

SI No.	Method of Test	Maximum Smoke Density	
		Light absorption coefficient (1/meter)	Hartridge units
(1)	(2)	(3)	(4)
1.	Free acceleration test for turbo charged engine and naturally aspirated engine for vehicle manufactured as per pre-Bharat Stage-IV norms	2.45	65
2.	Free acceleration test for turbo charged engine and naturally aspirated engine for vehicle manufactured as per Bharat Stage-IV norms.	1.62	50
3.	Free acceleration test for turbo charged engine and naturally aspirated engine for 4 wheelers manufactured as per Bharat Stage-VI norms.	0.7	26
4.	Free acceleration test for turbo charged engine and naturally aspirated engine for two/three wheelers manufactured as per Bharat Stage-VI norms.	1.5	48

8 TYPE APPROVAL

8.1 Type Approval of 4 Gas Analyzer

8.1.1 Documentation

The documentation for an instrument supplied by the manufacturer when applying for type approval shall include:

- a) A description of its general principle of measurement;
- b) A list of its essential components with their characteristics;
- c) A description of its essential components with drawings and diagrams that is necessary for testing and maintenance;
- d) The general information on the software required for a microprocessor equipped measuring instrument;
- e) For Lambda calculation or A/F calculation, a description of the applied formula with the values of the parameters and physical constants incorporated and evidence showing that the requirement of **4.2.10** is met shall be indicated in operating manual;
- f) General information related to electronically uploading of emissions test data to State Register of Motor Vehicles or Central Register of Motor Vehicles such as NIC web application URL, test procedure, etc.; and
- g) The operating instructions that shall be provided to the user.

Along with an application for type approval, the manufacturer shall provide any data or other information that may support the assertion that the design and construction of the Instrument complies the requirements.

8.1.2 General Requirements

Type approval shall be carried out on at least one and normally not more than three units, which represent the definitive pattern. The evaluation shall consist of the tests specified here under:

8.1.2.1 Inspection and tests

The inspection and testing of Instrument is intended to verify compliance with the requirements of **4.1.3, 4.2, 4.3, and 4.4.**

As a rule, tests should be carried out on the complete instrument or along with its connected peripheral devices like PC if these devices need to be compulsorily used for operating the instruments. However, if these devices are used only for printing / data acquisition purposes, the tests will be carried out on the instruments. The peripheral devices will not be subjected to all the environmental conditions but will be verified by the test agencies for the proper operation. If the size or configuration of the Instrument do not render it suitably to being tested as a unit, or, if only a particular component or device of the Instrument is concerned, a test may be carried out on the component or device separately. Such tests may only be performed if a simulated measurement set-up can be achieved that reflects the rated operating conditions of the component or device.

The contents of gas mixtures used during type approval shall conform to those specified in sections below (generally a measurand gas in N₂). For initial verification, subsequent verification and routine testing, the use of more realistic gas mixtures containing CO, CO₂ and HC in N₂ when applicable, should be considered.

NOTE — It is not intended that the instrument or its components should be dismantled for a test.

8.1.2.1.1 An instrument shall be given a visual inspection to obtain a general appraisal of its design and construction.

8.1.2.1.2 An instrument shall be tested according to **4.6** to determine its correct functioning.

8.1.2.1.3 The manufacturer's written operating instructions for an instrument shall be checked to ensure that correct procedures are clearly indicated, especially those specified in **4.5.2**.

8.1.3 Type approved 4 Gas Analyzer shall have following marking in addition to the marking given in 4.4.

- a) CMVR Type approval designation
- b) Type approval certificate number and model number

9 CONFORMITY OF PRODUCTION

9.1 Conformity of Production Procedure for Testing of 4 Gas Analyser

9.1.1 *Physical Checking and Verification*

- a) Instrument Model number;
- b) List of accessories;
- c) Sensor detector type and model number;
- d) Sample cell dimensions;
- e) All PCB model numbers, size and quantity;
- f) Display: type, number of digits, scale and resolution;
- g) Probe length and diameter;
- h) Input/output connectors and cables;
- j) Printout sample;
- k) Front panel controls;
- m) Electrical calibration; and
- n) Software programme version

9.1.2 Following tests as per type approval test procedure for 4 gas analyzer given in **4** shall be carried out for conformity of production test

- a) Check of the calibration curve;
- b) Environmental condition and electrical supply;

- c) Influence of gas components other than the measured (Cross sensitivity); and
- d) Measurement Test Data Acquisition and Electronic Upload.

9.1.3 In addition to above conformity test, the test certifying agencies, at their sole discretion, may determine to carry out any other test, if found necessary.

9.2 Conformity of Production Procedure for Testing of Smoke Meter

9.2.1 Physical Check

It shall consist of checking of following:

- a) Suitability and label on the instrument for the intended use;
- b) Identification of the instrument consisting of model, serial number, name and address of the manufacturer, electrical power requirement, year and month of manufacture and operating voltage range specified in English language;
- c) Scale, resolution, display;
- d) Peak hold facility;
- e) Heating facility;
- f) Calibration facility;
- g) Printout specifications;
- h) Documentation; and
- j) Verification of the following specifications:
 - 1) Accessories provided;
 - 2) Light source / detector / optical bench type & model no.;
 - 3) Smoke tube dimensions;
 - 4) All printed circuits boards (model nos., sizes, quantity);
 - 5) Display: type, no. of digits;
 - 6) Input/output connectors, cables;
 - 7) Front panel controls;
 - 8) Calibration filter value;
 - 9) Software programme version;
 - 10) Software programme version, URL;
 - 11) Oil temperature sensor probe;
 - 12) Engine speed sensor clamp / attachment; and
 - 13) Any other checks as found relevant

9.2.2 Linearity

For measurement of Smoke, engine speed and oil temperature, refer **5.2.2**

9.2.3 Temperature Sensitivity

For temperature sensitivity refer **5.2.9.2**.

9.3 FREE ACCELERATION CORRELATION TEST

For free acceleration correlation test refer **5.2.11**.

9.4 MEASUREMENT TEST DATA ACQUISITION AND ELECTRONIC UPLOAD

For measurement test data acquisition and electronic upload refer **5.2.12**.

9.5 In addition to above conformity test, the test agencies, at their sole discretion, may determine to carry out any other test, if found necessary.

10 BIS CERTIFICATION MARKING

10.1 Each Gas analyzer/Smoke meter may also be marked with the Standard Mark.

10.2 The use of the Standard Mark is governed by the provisions of the *Bureau of Indian Standards Act, 2016* and the Rules and Regulations made thereunder. The details of conditions under which the license for the use of the Standard Mark may be granted to manufacturers or producers may be obtained from the Bureau of Indian Standards.

ANNEX- A

(Foreword)

ADMINISTRATIVE PROCEDURE FOR COP TESTING OF 4 GAS ANALYSER AND DIESEL SMOKE METER

A-1 ADMINISTRATIVE PROCEDURE FOR COP TESTING

A-1.1 The Ministry of Road Transport and Highways, New Delhi (MoRTH) is the Nodal Agency for implementation of Emission Legislation.

A-1.2 The MoRTH had constituted a Committee under the Chairmanship of Joint Secretary (Transport) to formulate a standard uniform procedure for testing of gas analysers and smoke meters. This Committee has finalised the test specifications and procedure for type testing of smoke meters and Gas analysers (henceforth referred to as instrument).

A-1.3 This Committee has also decided to introduce conformity of production (COP) testing for the instrument manufactured / supplied in India to keep a check on the production quality of the instrument.

A-1.4 There is a Standing Committee on implementation of emission legislation constituted by MoRTH to advise the Nodal Agency in such implementation.

A-2 COP TEST AGENCIES

A-2.1 The test agencies carrying out the type testing will be responsible for carrying out the COP test.

A-2.2 Initially manufacturer / supplier has the option of choosing test agency for type approval of its specific model. On completion of first COP by the same test agency, the manufacturer can change the test agency if so desired.

A-2.3 In case the instrument manufacturer / supplier desires to change the COP test agency, a formal request shall be made to the new test agency under intimation to the previous test agency and nodal agency. This request shall be made at least one month before the next COP is due along with all relevant documents concerning type approval / previous COP.

A-2.4 On receipt of intimation of request for a change, the previous COP test agency will authenticate all the relevant documents of that model and forward to the new test agency. The new test agency will carry out the process of selection and testing of the instrument(s) for COP as per the procedure and will consult the previous test agency, if required, about the test findings and results before issuing the final COP certificate.

A-3 COP TESTING CRITERIA

A-3.1 The COP period for an instrument model shall be 2.5 years from the date of type approval certification or 2.5 years from the date of last COP certificate or supply of 200 units of the type approved instrument model from the date of type approval certification or supply of 200 units from date of last COP certificate or resumption of supply of the instrument model, whichever is earlier.

The instrument manufacturer / supplier may request the Nodal Agency for relaxation of the above period with justification. The Nodal Agency will take a decision based on the merit of

the case.

If the production and supply of an instrument model is discontinued, it should either coincide with COP test or COP test should be performed before the instrument model is discontinued even though COP criteria is not applicable.

A-3.2 An instrument is considered to be supplied when the instrument has been dispatched from the instrument manufacturer / supplier's premises.

A-3.3 The instrument manufacturer / supplier shall inform the Nodal Agency and the concerned test agency as soon as 180 units have been supplied, and/or, after 28 months have passed from the date of type approval certificate or date of last COP certificate. The concerned test agency shall keep the track regarding this and in case the information is not received from the manufacturer / supplier, inform the Nodal Agency accordingly.

A-3.4 Test agency shall ask for an instrument model Type Approved for COP testing before the COP period. The instrument manufacturer / supplier shall submit the instrument unit randomly selected by the concerned test agency from the production numbers furnished by the instrument manufacturer after the receipt of this request.

The instrument manufacturer / supplier shall provide sufficient documents along with the instrument to support the fact that this is the instrument unit selected by the concerned test agency. The documents could be production final check documents showing the instrument serial number, bill of entry / purchase order in case of imported equipment, etc.

A-4 COP TESTING

The COP testing procedure for 4 Gas analyser and Smoke meter are given in **9.1** and **9.2** respectively.

A-5 MODEL CHANGE AND VARIANCE

A-5.1 Generally, whenever there is a change in sensor, detector, electronic circuits, software, etc. it shall be treated as new model and separate model number shall be given by the manufacturer / supplier. If any part is indigenised or there is any minor modification subsequent to the type approval testing, which will not affect the function of the instrument, the instrument manufacturer / supplier shall inform the details of such modifications / changes to the test agency and the test agency shall decide whether any retesting is to be carried out either in part or full based on assessment of the impact such modification / change may have on the performance of the instrument.

A-6 CERTIFICATE

A-6.1 If the instrument meets the requirements of COP testing, the test agency will issue a COP Certificate to the manufacturer / supplier for the particular instrument model. The test agency will also send the copies of the COP certificate to other testing agencies and the Nodal Agency.

A-7 CONSEQUENCE OF COP FAILURE

A-7.1 If the instrument fails to meet the requirements of COP, the test agency shall send the copies of the COP Failure Report to the Nodal Agency and the manufacturer / supplier. The Nodal Agency will take a decision and convey the same to the manufacturer / supplier and the test agencies within 4 weeks from the receipt of the COP Failure Report. The Nodal Agency may decide to call a meeting of the Standing Committee (SCOE) to discuss and advise the Nodal Agency. The instrument manufacturer / supplier may be given an opportunity to present its case to the Committee before advising the Nodal Agency. Upon reaching the decision, the Nodal Agency will issue the order for withdrawal of Type Approval Certificate and stop

dispatch of the instruments by the manufacturer / supplier from its works or re-testing of the instrument model, re-testing of the same instrument unit after modifications and / or testing of additional units of the instrument.

A-7.2 In case the Type Approval Certificate has been withdrawn, as per 7.1, the manufacturer / supplier can subsequently identify the reasons for not meeting the COP and necessary corrective measures. Then they shall inform the same to the Nodal Agency and the concerned test agency and offer the rectified instrument for testing. The test agency shall carry out a complete test as per the Type Approval procedure on the rectified instrument. If the instrument meets the relevant Type Approval norms, the manufacturer / supplier shall write to the Nodal Agency and the concerned test agency which has carried out the test, and inform about the modifications which are to be finally carried out on the instruments to be supplied in future and the instruments which have been supplied during the previous COP period and which require retrofitting rectifications.

Type Approval will be restored by the Nodal Agency subject to 7.3. Further a special COP will be carried out after 25 number of units have been supplied, from the date of re-testing of the instrument as per Type Approval procedure, using standard COP procedure.

A-7.3 It is the responsibility of the instrument manufacturer / supplier to ensure, at his cost, that the modifications / modified components are carried out / retrofitted within a period, specified by the Nodal Agency on all instruments supplied during the period between the dates test agency has sent the test report and restoration of the Type Approval by the Nodal Agency as per 7.2.

A-8 CODE OF PRACTICE FOR PUC EQUIPMENT MANUFACTURER / SUPPLIER

A-8.1 Based on the decision adopted in the Standing Committee on Emissions (SCOE) meeting held on 28th March 2003, every PUC equipment manufacturer / supplier shall comply with the following Code of Practice and submit an affidavit for the same along with the instrument model submitted for Type Approval to the concerned Test Agency.

A-8.1.1 PUC equipment manufacturer / supplier shall include the description of the test procedure described in 6 or 7, whichever is applicable, as amended from time to time in the user's manual of the PUC equipment.

A-8.1.2 PUC equipment manufacturer / supplier shall provide copy of Type Approval certificate with date of validity along with the PUC equipment.

A-8.1.3 The validity of the Type Approval certificate of the PUC equipment shall be 5 years from the date of the certificate, after the expiry of which the PUC equipment manufacturer / supplier shall get it re-validated from the concerned test agency.

A-8.1.4 PUC equipment manufacturer / supplier shall provide the status of production / supply of PUC equipment at a regular interval of 1 year to the test agency from where the equipment has been certified.

A-8.1.5 PUC equipment manufacturer / supplier shall submit the equipment for COP as per procedure mentioned above.

A-8.1.6 PUC equipment manufacturer / supplier shall enter into an "Annual Maintenance Contract" (AMC), for a period of 5 years, with the authorized PUC test agency based on agreed charges. The AMC shall be comprehensive (including spare parts) but does not include maintenance of PC / PC peripherals of the computerized PUC equipment. This AMC contract shall include 3 visits per year and equipment calibration. PUC equipment manufacturer / supplier shall provide calibration certificate.

A-8.1.7 PUC equipment manufacturer/supplier shall train minimum 3 operators of PUC test agency.

A-9 CODE OF PRACTICE FOR AUTHORISED PUC TEST AGENCIES

A-9.1 The PUC test agencies authorized for issue of “Pollution Under Control Certificate” shall comply with following Code of Practice:

A-9.1.1 The Type Approval certificate supplied by PUC equipment manufacturer / supplier shall be displayed in the PUC center.

A-9.1.2 The operator training certificate issued by PUC equipment manufacturer / supplier shall be displayed in the PUC center.

A-9.1.3 PUC operator shall submit the monthly report of all tested in-use vehicles along with test printout in original to the Transport Department.

A-9.1.4 PUC operator shall enter into AMC for a period of 5 years with the respective PUC equipment manufacturer based on the finalized charges.

ANNEX- B

(Foreword)

**COMMITTEE COMPOSITION
IN SERVICE VEHICLE INSPECTION, CERTIFICATION AND GARAGE
EQUIPMENT SECTIONAL COMMITTEE, TED 31**

<i>Organization</i>	<i>Representative(s)</i>
NATIONAL AUTOMOTIVE TEST TRACKS, DHAR	SHRI MANISH JAISWAL (<i>Chairman</i>)
AVL India Private Limited, Pune	SHRI MUNSARIF IZHAR ANSARI SHRI IFTEKHAR HASAN (<i>Alternate</i>)
Actia India Private Limited, Noida	SHRI ANURAG JAIN SHRI ARVIND SAXENA (<i>Alternate</i>)
Ashok Leyland Limited, Chennai	SHRI VED PRAKASH GAUTAM SHRI N KUMARAN (<i>Alternate</i>)
Association of State Road Transport Undertakings, New Delhi	SHRI R R K KISHORE SHRI SACHIN MOTIRAM CHACHARE (<i>Alternate</i>)
Automotive Research Association of India, Pune	SHRI JAYANT BHALERAO SHRI NITIN B DHANDE (<i>Alternate</i>)
Central Institute of Road Transport, Pune	SHRI S. N. DHOLE SHRI S. N. GUTTE (<i>Alternate</i>)
Central Pollution Control Board, New Delhi	SHRI ANKUSH TEWANI
Global Automotive Research Centre, Oragaram	DR. A. S. RAMADHAS SHRI V GOKUL (<i>Alternate</i>)
Hero Motocorp Limited, New Delhi	SHRI FERAZ ALI KHAN SHRI PIYUSH CHOWDHRY (<i>Alternate</i>)
MAHA India Automotive Testing Equipment Private Limited, New Delhi	SHRI RENGARAJAN ULAGANATHAN SHRI SYED SHAHABUDDIN (<i>Alternate</i>)
Manatec Electronics Private Limited, Puducherry	SHRI MUTHAZHAGAN M SHRI MOORTHY A (<i>Alternate</i>)
Maruti Suzuki India Limited, Gurugram	SHRI GURURAJ RAVI SHRI RAJ KUMAR DWIVEDI (<i>Alternate</i>)
Ministry of Electronics and Information Technology, New Delhi	DR. BHARAT KUMAR YADAV
National Automotive Test Tracks, Dhar	SHRI KIRAN N MULKI (<i>Alternate</i>)
Rosmerta Technologies Limited, Gurugram	SHRI PUNIT TALWAR
SGS India Private Limited, Mumbai	SMT DIPJYOTI BANERJEE SHRI AMIT MEHTA (<i>Alternate</i>)
SMS Autoline Equipments Private Limited, Chennai	SHRI SUNDARA GANESH R SHRI J SHAFFI HUSSAIN (<i>Alternate</i>)
Society of Indian Automobile Manufacturers (SIAM), Delhi	SHRI PRASHANT KUMAR BANERJEE SHRI KARTIKE KARWAL (<i>Alternate</i>)
TUV Nord (TUV India Private Limited), Bengaluru	SHRI VISWANATHAN
TUV-SUD South Asia Private Limited, Bengaluru	SHRI SUMIT SINGHAL
Transport Department, Government of NCT of Delhi, New Delhi	SHRI ANIL CHHIKARA
Volkswagen India Private Limited, Mumbai	SHRI SHRINIWAS P CHAKRAVARTHY SHRI SRIRAM RAI (<i>Alternate</i>)
Weight and Measurement Department, Government of NCT of Delhi, New Delhi	SHRI PRADEEP KUMAR TRIPATHI SHRI KRISHAN KUMAR NIGAM (<i>Alternate</i>)
international Centre for Automotive Technology, Manesar	SHRI SITIKANTHA PADHY SHRI SUNIL BAKSHI (<i>Alternate</i>)
BIS Directorate General	SHRI DEEPAK AGGARWAL SCIENTIST 'F'/SENIOR DIRECTOR AND HEAD (TRANSPORT ENGINEERING DEPARTMENT) [REPRESENTING DIRECTOR GENERAL (Ex-officio)]

MEMBER SECRETARY
SHRI GAURAV JAYASWAL

TED 31 (20653) F
IS XXXX: 2024

SCIENTIST C / DEPUTY DIRECTOR
(TRANSPORT ENGINEERING DEPARTMENT)