**Optics and photonics — Microlens
arrays —**

Part 5:
Guidance on testing

*Optique et photonique — Réseaux de microlentilles —
Partie 5: Lignes directrices pour essai*



PDF disclaimer

This PDF file may contain embedded typefaces. In accordance with Adobe's licensing policy, this file may be printed or viewed but shall not be edited unless the typefaces which are embedded are licensed to and installed on the computer performing the editing. In downloading this file, parties accept therein the responsibility of not infringing Adobe's licensing policy. The ISO Central Secretariat accepts no liability in this area.

Adobe is a trademark of Adobe Systems Incorporated.

Details of the software products used to create this PDF file can be found in the General Info relative to the file; the PDF-creation parameters were optimized for printing. Every care has been taken to ensure that the file is suitable for use by ISO member bodies. In the unlikely event that a problem relating to it is found, please inform the Central Secretariat at the address given below.



COPYRIGHT PROTECTED DOCUMENT

© ISO 2010

All rights reserved. Unless otherwise specified, no part of this publication may be reproduced or utilized in any form or by any means, electronic or mechanical, including photocopying and microfilm, without permission in writing from either ISO at the address below or ISO's member body in the country of the requester.

ISO copyright office
Case postale 56 • CH-1211 Geneva 20
Tel. + 41 22 749 01 11
Fax + 41 22 749 09 47
E-mail copyright@iso.org
Web www.iso.org

Published in Switzerland

Contents

Page

Foreword	iv
Introduction.....	v
1 Scope	1
2 Normative references	1
3 Terms and definitions	1
4 Symbols and units.....	1
5 Coordinate system	2
6 Test conditions	3
7 Test guide.....	4
7.1 General	4
7.2 Guide to test with measurement equipment	4
7.3 Measurements possible with specific equipment.....	6
7.4 Measurement equipment for testing properties of a microlens	8
7.4.1 Test method flow chart	8
7.4.2 Test methods for optical properties of a single microlens	9
7.4.3 Test methods for geometrical properties of single microlenses	10
7.4.4 Test methods for optical properties of microlens arrays.....	10
7.4.5 Test methods for geometrical properties of microlens arrays	11
8 Test report.....	11
Annex A (informative) Measurement guide for microlens property test.....	12
Annex B (informative) Discussion of Annexes to ISO 14880-2, ISO 14880-3 and ISO 14880-4.....	14
Bibliography.....	17

Foreword

ISO (the International Organization for Standardization) is a worldwide federation of national standards bodies (ISO member bodies). The work of preparing International Standards is normally carried out through ISO technical committees. Each member body interested in a subject for which a technical committee has been established has the right to be represented on that committee. International organizations, governmental and non-governmental, in liaison with ISO, also take part in the work. ISO collaborates closely with the International Electrotechnical Commission (IEC) on all matters of electrotechnical standardization.

International Standards are drafted in accordance with the rules given in the ISO/IEC Directives, Part 2.

The main task of technical committees is to prepare International Standards. Draft International Standards adopted by the technical committees are circulated to the member bodies for voting. Publication as an International Standard requires approval by at least 75 % of the member bodies casting a vote.

In exceptional circumstances, when a technical committee has collected data of a different kind from that which is normally published as an International Standard ("state of the art", for example), it may decide by a simple majority vote of its participating members to publish a Technical Report. A Technical Report is entirely informative in nature and does not have to be reviewed until the data it provides are considered to be no longer valid or useful.

Attention is drawn to the possibility that some of the elements of this document may be the subject of patent rights. ISO shall not be held responsible for identifying any or all such patent rights.

ISO/TR 14880-5 was prepared by Technical Committee ISO/TC 172, *Optics and photonics*, Subcommittee SC 9, *Electro-optical systems*.

ISO 14880 consists of the following parts, under the general title *Optics and photonics — Microlens arrays*:

- *Part 1: Vocabulary*
- *Part 2: Test methods for wavefront aberrations*
- *Part 3: Test methods for optical properties other than wavefront aberrations*
- *Part 4: Test methods for geometrical properties*
- *Part 5: Guidance on testing* [Technical Report]

Introduction

This part of ISO 14880 is intended as a guide to the selection and use of the appropriate method for testing optical and geometrical properties of a single microlens or microlens arrays. Examples of applications for microlens arrays include three-dimensional displays, coupling optics associated with arrayed light sources and photo-detectors, enhanced optics for liquid crystal displays, and optical parallel processor elements.

The testing of microlenses is in principle no different to testing any other lens. The same parameters need to be measured and the same techniques used. However, in many cases the measurement of very small lenses presents practical problems which make it difficult to use the standard equipment that is available for testing normal-size lenses.

The growing market in microlens arrays has generated a need for agreement on basic terminology and test methods. Standard terminology and clear definitions are needed not only to promote applications but also to encourage scientists and engineers to exchange ideas and new concepts based on common understanding.

The purpose of ISO 14880 is to improve the compatibility and interchange ability of lens arrays from different suppliers and to enhance development of the technology that uses microlens arrays. The various parts of ISO 14880 define terms and describe methods for testing wavefront aberrations, optical properties other than wavefront aberrations, and test methods for geometrical properties. This part of ISO 14880 contributes to the purpose by guiding the user to select the appropriate part of ISO 14880 for testing microlens properties, however the user is not limited to these techniques.

Optics and photonics — Microlens arrays —

Part 5: Guidance on testing

1 Scope

This part of ISO 14880 gives guidelines for the testing of microlenses. It applies to microlenses in arrays where very small lenses are formed inside or on one or more surfaces of a common substrate.

This part of ISO 14880 addresses the measurement of optical and geometrical properties of single microlenses as well as microlens arrays.

When testing a microlens or microlens array, the test method is selected according to the parameters to be measured, the size and structure of the microlens and its application. This part of ISO 14880 guides the user to select the appropriate measurement method from the available ISO standards.

2 Normative references

The following referenced documents are indispensable for the application of this document. For dated references, only the edition cited applies. For undated references, the latest edition of the referenced document (including any amendments) applies.

ISO 14880-1, *Optics and photonics — Microlens arrays — Part 1: Vocabulary*

3 Terms and definitions

For the purposes of this document, the terms and definitions given in ISO 14880-1 apply.

4 Symbols and units

Symbols and units of measurement that are used in this part of ISO 14880 are given in Table 1.

Table 1 — Symbols and units of measurement

	Symbol	Unit	Term
1	A_d	mm ²	diffraction-limited optical aperture
2	A_g	mm ²	geometric aperture
3	a_1, a_2	mm	lens radius
4	$2a_1, 2a_2$	mm	lens width
5	D_n	mm ⁻²	lens density
6	h	mm	surface modulation depth
7	L_1, L_2	mm	edge length of substrate
8	NA	none	numerical aperture
9	NA_d	none	diffraction limited numerical aperture
10	NA_g	none	geometrical numerical aperture
11	$n(x, y, z)$	none	refractive index
12	n_0	none	refractive index (lens centre)
13	P_x, P_y	mm	pitch
14	$f_{E,b}$	mm	effective back focal length
15	$f_{E,f}$	mm	effective front focal length
16	R_c	mm	radius of curvature
17	S_x, S_y, S_z	mm	coordinates of focal spot position
18	$\Delta S_x, \Delta S_y, \Delta S_z$	mm	focal spot position shift
19	T	mm	thickness of substrate
20	T_c	mm	physical thickness
21	W_x, W_y	mm	focal spot size
22	x, y, z	mm	coordinate of lens aperture centre position
23	θ	degree	acceptance angle
24	Φ_{rms}	parts of the wavelength, λ	wavefront aberration
25	λ	μm	wavelength
26	ν_{eff}	none	effective Abbe-number

5 Coordinate system

A Cartesian coordinate system as shown in Figure 1 can be used to describe the radiation propagation in a microlens array. Most parameters to be measured relate to individual microlenses.

The fundamental structure of a microlens array is illustrated in Figure 2.

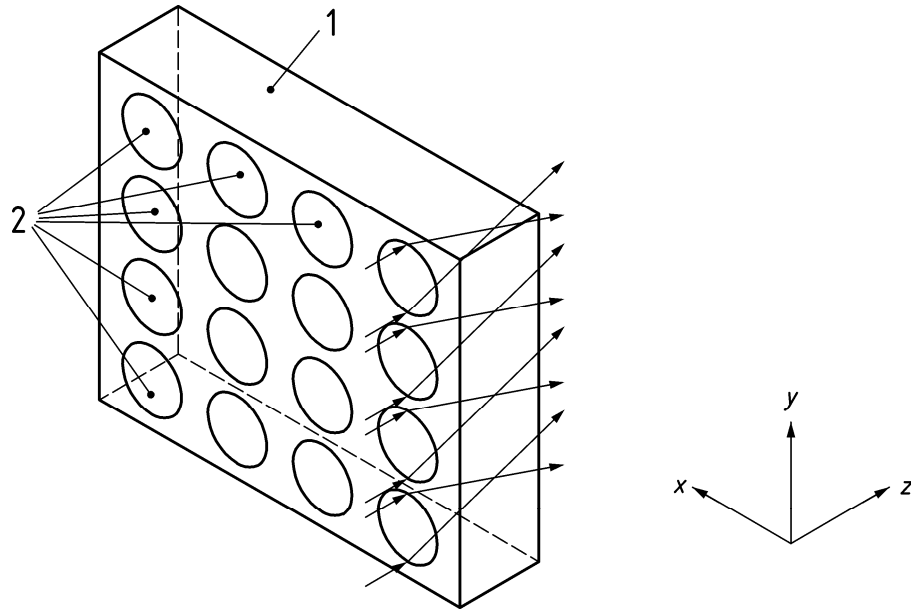

Key

- 1 Substrate
- 2 Microlens

Figure 1 — Microlens array with a Cartesian coordinate system

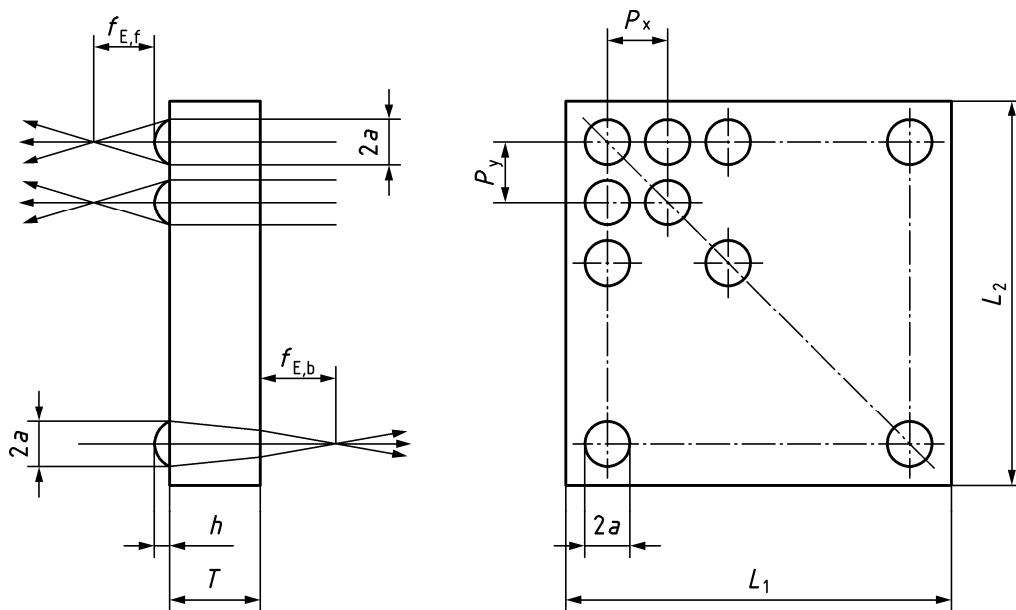

Figure 2 — Fundamental structure of microlens array

6 Test conditions

Care should be taken to ensure the test samples and equipment are handled under the conditions described in the appropriate standard, e.g. ISO 14880-2.

7 Test guide

7.1 General

It is usually necessary to ensure optical surfaces are clean before measurement.

7.2 Guide to test with measurement equipment

Table 2 shows several measurement methods and types of equipment which can be used to measure parameters.

For example, a lens radius (a_1 , a_2) can be measured with a stylus instrument, a confocal measurement system or a microscope with linear scale.

Table 2 — Test equipment and reference standard for parameters to be measured

	Symbol	Unit	Term (parameter to be measured)	Equipment	Reference standards
1	A_d	mm ²	diffraction-limited optical aperture	microscope with linear scale	—
				interferometer with aperture stop and linear scale	—
2	A_g	mm ²	geometrical aperture	micrometer	—
				microscope with linear scale	—
3	a_1, a_2	mm	lens radius	stylus instrument	ISO 14880-4
				confocal measurement systems	ISO 14880-4
				microscope with linear scale	—
4	$2a_1, 2a_2$	mm	lens width	stylus instrument	ISO 14880-4
				confocal measurement systems	ISO 14880-4
				microscope with linear scale	—
5	D_n	mm ⁻²	lens density	stylus instrument	ISO 14880-4
				confocal measurement systems	ISO 14880-4
				microscope with linear scale	—
6	h	mm	surface modulation depth	stylus instrument	ISO 14880-4
				confocal measurement systems	ISO 14880-4
7	L_1, L_2	mm	edge lengths of substrate	microscope with linear scales	—
8	NA	none	numerical aperture	calculated from aperture and focal length values	—
				measured directly from the divergence introduced by the microlens when illuminated by a collimated beam	—
9	NA_d	none	diffraction-limited numerical aperture	calculated from diffraction-limited aperture and focal length values	—
10	NA_g	none	geometrical numerical aperture	calculated from geometrical aperture and focal length values	—

Table 2 (continued)

	Symbol	Unit	Term (parameter to be measured)	Equipment	Reference standards
11	$n(x, y, z)$	none	refractive index	refractometer, for example Abbe or Pulfrich type or interferometer such as Mach-Zehnder or shearing type	—
12	n_0	none	refractive index (lens centre)	refractometer, for example Abbe or Pulfrich type or interferometer such as Mach-Zehnder or shearing type	—
13	P_x, P_y	mm	pitch	stylus instrument	ISO 14880-4
				microscope with linear scale	—
14	$f_{E,b}$	mm	effective back focal length	collimated source and microscope	ISO 14880-3
				wavefront measuring systems with linear scale	ISO 14880-3
				confocal measurement systems	ISO 14880-3
15	$f_{E,f}$	mm	effective front focal length	collimated source and microscope	ISO 14880-3
				wavefront measuring systems with linear scale	ISO 14880-3
				confocal measurement systems	ISO 14880-3
16	R_c	mm	radius of curvature	collimated source and microscope	ISO 14880-4
				interferometer with linear scale	ISO 14880-4
17	S_x, S_y, S_z	mm	coordinates of focal spot position	microscope with linear scale	—
18	$\Delta S_x, \Delta S_y, \Delta S_z$	mm	focal spot position shift	microscope with linear scale	—
19	T	mm	thickness of substrate	micrometer	—
20	T_c	mm	physical thickness	micrometer	ISO 14880-4
21	W_x, W_y	mm	focal spot size	image sensor camera	—
22	x, y, z	mm	coordinates of lens aperture centre position	microscope with linear scale	—
23	θ	degree	acceptance angle	gonio photometer	—
24	Φ_{rms}	parts of the wavelength, λ	wavefront aberration	interferometer	ISO 14880-2 ISO 10110-14
				Shack-Hartmann sensor	ISO 14880-2
25	λ	μm	wavelength	spectrometer	—
26	ν_{eff}	none	effective Abbe-number	effective Abbe-number is given by: $\nu_{\text{eff}} = \frac{1}{\frac{1}{f(\lambda_1)} - \frac{1}{f(\lambda_2)}}$	ISO 14880-3
27	CE	none	coupling efficiency	calculated from Strehl ratio	ISO 14880-3

Table 2 (continued)

	Symbol	Unit	Term (parameter to be measured)	Equipment	Reference standards
28	IQ	none	imaging quality	test chart projection	—
				calculated wavefront analysis	ISO 14880-2
				MTF analysis	ISO 15529
29	<i>uniformity</i>	none	uniformity of array	pair of similar lens arrays to generate moiré patterns Also, measurements on single lenses sampled from array may give a good indication.	ISO 14880-4

7.3 Measurements possible with specific equipment

Table 3 shows measurement methods and equipments which can be used to measure single microlens and/or microlens array properties. Several properties may be measured with each piece of equipment.

Table 3 — Measurements possible with specific equipment

	Equipment	S	A	O	G	Symbol	Unit	Term	Reference standards	
A	collimated source and microscope	#		#	14	$f_{E,b}$	mm	effective back focal length	ISO 14880-3	
		#		#	15	$f_{E,f}$	mm	effective front focal length	ISO 14880-3	
		#		#	16	R_c	mm	radius of curvature	ISO 14880-4	
B	effective Abbe-number is given by: $v_{\text{eff}} = \frac{1}{\frac{1}{f(\lambda_2)} - \frac{1}{f(\lambda_1)} - \frac{1}{f(\lambda_3)}}$ calculated from appropriate aperture and focal length values	#		#	26	v_{eff}	none	effective Abbe-number (chromatic aberration)	ISO 14880-3	
		#		#	8	NA	none	numerical aperture	—	
		#		#	9	NA_d	none	diffraction-limited numerical aperture	—	
		#		#	10	NA_g	none	geometrical numerical aperture	—	
		#		#	27	CE	none	coupling efficiency	ISO 14880-3	
	calculated wavefront analysis	#		#	28	IQ	none	imaging quality	ISO 14880-2	
C	confocal measurement systems	#		#	14	$f_{E,b}$	mm	effective back focal length	ISO 14880-3	
		#		#	15	$f_{E,f}$	mm	effective front focal length	ISO 14880-3	
		#	#		#	3	a_1, a_2	mm	lens radius	ISO 14880-4
		#	#		#	4	$2a_1, 2a_2$	mm	lens width	ISO 14880-4
			#		#	5	D_n	mm ⁻²	lens density	ISO 14880-4
			#		#	6	h	mm	surface modulation depth	ISO 14880-4

Table 3 (continued)

	Equipment	S	A	O	G	Symbol	Unit	Term	Reference standards	
D	pair of similar lens arrays to generate moiré patterns		#		#	29	<i>uniformity</i>	none	uniformity of array	ISO 14880-4
E	gonio photometer	#		#		23	θ	degree	acceptance angle	—
F	image sensor camera	#		#		21	W_x, W_y	mm	focal spot size	—
G	refractometer, for example Abbe or Pulfrich type	#		#		11	$n(x, y, z)$	none	refractive index	—
		#		#		12	n_0	none	refractive index (lens centre)	—
H	interferometer	#		#		24	Φ_{rms}	parts of the wavelength, λ	wavefront aberration	ISO 14880-2 ISO 10110-14
	interferometer with linear scale	#			#	16	R_c	mm	radius of curvature	ISO 14880-4
	interferometer with aperture stop and linear scale	#		#		1	A_d	mm ²	Diffraction-limited optical aperture	—
	interferometer such as Mach-Zehnder or shearing type	#		#		11	$n(x, y, z)$	none	refractive index	—
#			#		12	n_0	none	refractive index (lens centre)	—	
I	micrometer		#		#	20	T_c	mm	physical thickness	ISO 14880-4
			#		#	19	T	mm	thickness of substrate	—
						2	A_g	mm ²	geometrical aperture	—
J	microscope with linear scale	#			#	1	A_d	mm ²	diffraction-limited optical aperture	—
		#			#	2	A_g	mm ²	geometrical aperture	—
		#			#	3	a_1, a_2	mm	lens radius	—
		#			#	4	$2a_1, 2a_2$	mm	lens width	—
		#			#	5	D_n	mm ⁻²	lens density	—
		#			#	7	L_1, L_2	mm	edge lengths of substrate	—
		#			#	13	P_x, P_y	mm	pitch	—
		#	#			17	S_x, S_y, S_z	mm	coordinates of focal spot position	—
		#	#			18	$\Delta S_x, \Delta S_y, \Delta S_z$	mm	focal spot position shift	—
		#	#		22	x, y, z	mm	coordinates of lens aperture centre position	—	
K	MTF analysis	#		#		28	<i>IQ</i>	none	imaging quality	ISO 15529
L	Shack-Hartmann sensor	#		#		24	Φ_{rms}	parts of the wavelength, λ	wavefront aberration	ISO 14880-2
M	stylus instrument	#			#	3	a_1, a_2	mm	lens radius	ISO 14880-4
		#			#	4	$2a_1, 2a_2$	mm	lens width	ISO 14880-4
		#			#	5	D_n	mm ⁻²	lens density	ISO 14880-4
		#			#	6	h	mm	surface modulation depth	ISO 14880-4
		#			#	13	P_x, P_y	mm	pitch	ISO 14880-4

Table 3 (continued)

	Equipment	S	A	O	G	Symbol	Unit	Term	Reference standards	
N	test chart projection	#		#		28	IQ	none	imaging quality	—
O	wavefront measuring systems with linear scale	#		#		14	$f_{E,b}$	mm	effective back focal length	ISO 14880-3
		#		#		15	$f_{E,f}$	mm	effective front focal length	ISO 14880-3
P	spectrometer					25	λ	μm	wavelength	—

(S: single microlens test; A: microlens array test; O: optical property; G geometrical property)

7.4 Measurement equipment for testing properties of a microlens

7.4.1 Test method flow chart

The flowchart for choosing a suitable method for testing microlenses is shown in Figure 3. The first check is whether the size permits the lens test to be made in the conventional way. The test route is determined by whether the test object is a single lens, whether it is a lens array and whether the optical properties or the geometrical properties are to be tested.

If a lens diameter size is approximately 1 mm or less, the test method can be used as shown in Table 4 to Table 7.

In the case of a single microlens, the test methods shown in Table 4 for optical properties and in Table 5 for geometrical properties can be used.

In the case of a microlens array, the test methods shown in Table 6 for optical properties and in Table 7 for geometrical properties can be used.

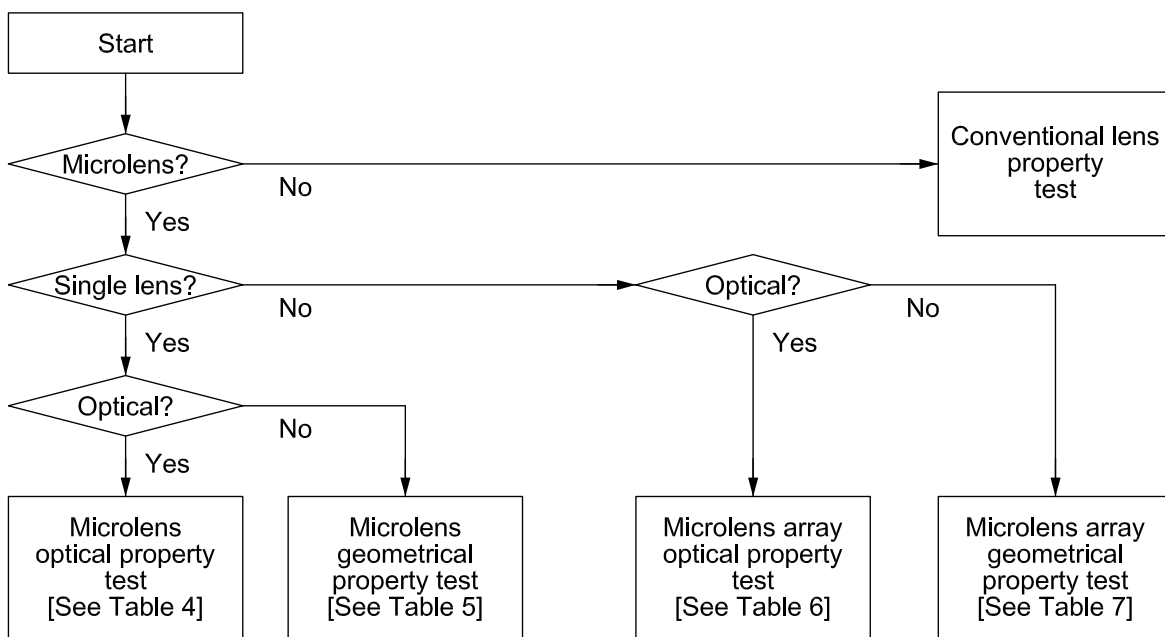

Figure 3 — Flow chart for selecting test method

7.4.2 Test methods for optical properties of a single microlens

Table 4 lists the test methods for optical properties of a single microlens.

Table 4 — Test methods for optical properties of a single microlens

	Equipment		Symbol	Unit	Term	Reference standards
A	collimated source and microscope	14	$f_{E,b}$	mm	effective back focal length	ISO 14880-3
		15	$f_{E,f}$	mm	effective front focal length	ISO 14880-3
B	effective Abbe-number is given by: $v_{\text{eff}} = \frac{1}{\frac{1}{f(\lambda_2)} - \frac{1}{f(\lambda_1)} - \frac{1}{f(\lambda_3)}}$	26	v_{eff}	none	effective Abbe-number (chromatic aberration)	—
	calculated from aperture and focal length values	8	NA	none	numerical aperture	—
	calculated wavefront analysis	28	IQ	none	imaging quality	ISO 14880-2
	calculated from diffraction-limited aperture and focal length values	9	NA_d	none	diffraction-limited numerical aperture	—
	calculated from geometrical aperture and focal length values	10	NA_g	none	geometrical numerical aperture	—
	calculated from Strehl ratio	27	CE	none	coupling efficiency	ISO 14880-3
C	confocal measurement systems	14	$f_{E,b}$	mm	effective back focal length	ISO 14880-3
		15	$f_{E,f}$	mm	effective front focal length	ISO 14880-3
E	gonio photometer	23	θ	degree	acceptance angle	—
F	image sensor camera	21	W_x, W_y	mm	focal spot size	—
G	refractometer, for example Abbe or Pulfrich type	11	$n(x, y, z)$	none	refractive index	—
		12	n_0	none	refractive index (lens centre)	—
H	interferometer	24	Φ_{rms}	parts of the wavelength, λ	wavefront aberration	ISO 14880-2 ISO 10110-14
	interferometer with aperture stop and linear scale	1	A_d	mm ²	Diffraction-limited optical aperture	—
	interferometer such as Mach-Zehnder or shearing type	11	$n(x, y, z)$	none	refractive index	—
		12	n_0	none	refractive index (lens centre)	—
K	MTF analysis	28	IQ	none	imaging quality	ISO 15529
L	Shack-Hartmann sensor	24	Φ_{rms}	parts of the wavelength, λ	wavefront aberration	ISO 14880-2
N	test chart projection	28	IQ	none	imaging quality	—
O	wavefront measuring systems with linear scale	14	$f_{E,b}$	mm	effective back focal length	ISO 14880-3
		15	$f_{E,f}$	mm	effective front focal length	ISO 14880-3

7.4.3 Test methods for geometrical properties of single microlenses

Table 5 lists test methods for the geometrical properties of a single microlens.

Table 5 — Test methods for geometrical properties of a single microlens

	Equipment		Symbol	Unit	Term	Reference standards
A	collimated source and microscope	16	R_c	mm	radius of curvature	ISO 14880-4
C	confocal measurement systems	3	a_1, a_2	mm	lens radius	ISO 14880-4
		4	$2a_1, 2a_2$	mm	lens width	ISO 14880-4
H	Interferometer with linear scale	16	R_c	mm	radius of curvature	ISO 14880-4
J	microscope with linear scale	1	A_d	mm ²	diffraction-limited optical aperture	—
		2	A_g	mm ²	geometrical aperture	—
		3	a_1, a_2	mm	lens radius	—
		4	$2a_1, 2a_2$	mm	lens width	—
M	stylus instrument	3	a_1, a_2	mm	lens radius	ISO 14880-4
		4	$2a_1, 2a_2$	mm	lens width	ISO 14880-4

7.4.4 Test methods for optical properties of microlens arrays

Table 6 lists methods for testing the optical properties of microlens arrays.

Table 6 — Test methods for optical properties of microlens arrays

	Equipment		Symbol	Unit	Term	Reference standards
J	Microscope with linear scale	17	S_x, S_y, S_z	mm	coordinates of focal spot position	—
		18	$\Delta S_x, \Delta S_y, \Delta S_z$	mm	focal spot position shift	—
		22	x, y, z	mm	coordinates of lens aperture centre position	—

7.4.5 Test methods for geometrical properties of microlens arrays

Table 7 lists methods for testing the geometrical properties of microlens arrays.

Table 7 — Test methods for geometrical properties of microlens arrays

	Equipment		Symbol	Unit	Term	Reference standards
C	confocal measurement systems	3	a_1, a_2	mm	lens radius	ISO 14880-4
		4	$2a_1, 2a_2$	mm	lens width	ISO 14880-4
		5	D_n	mm ⁻²	lens density	ISO 14880-4
		6	h	mm	surface modulation depth	ISO 14880-4
D	pair of similar lens arrays to generate moiré patterns	29	<i>uniformity</i>	none	uniformity of array	ISO 14880-4
I	micrometer	20	T_c	mm	physical thickness	ISO 14880-4
		19	T	mm	thickness of substrate	—
		2	A_g	mm ²	geometrical aperture	—
J	microscope with linear scale	5	D_n	mm ⁻²	lens density	—
		7	L_1, L_2	mm	edge lengths of substrate	—
		13	P_x, P_y	mm	pitch	—
M	stylus instrument	5	D_n	mm ⁻²	lens density	ISO 14880-4
		6	h	mm	surface modulation depth	ISO 14880-4
		13	P_x, P_y	mm	pitch	ISO 14880-4

8 Test report

The format for reporting the results of measurement is given in the appropriate standard, e.g. ISO 14880-2.

Annex A (informative)

Measurement guide for microlens property test

The performance of a microlens depends on the lens size, the lens form and the method of production. The measurement method will also vary with the structure of the microlens. It is possible to make microlenses as purely refractive elements with uniform refractive index, as graded index lenses and as diffractive element lenses.

Figure A.1 shows the dimensional range over which microlenses are feasible. It compares refractive lenses and diffractive lenses; generally the focal length of a diffractive lens is larger than a refractive lens of the same diameter. The Fresnel number, F , of a diffractive lens is smaller than that of a refractive lens.

As for a refractive lens, the fast aperture lens with a short focal length is easier to fabricate compared to a diffractive lens. This is especially true if the refractive index of the substrate is high, which leads to a shorter focal length for a given surface curvature.

Depending on the lens size, microlenses have different properties to conventional lenses. Methods for testing parameters such as focal length and wavefront aberration are different.

For example, the Fizeau type interferometer is generally used for testing wavefront aberrations. This is a double-pass interferometer and the measurement beam passes through the test lens twice. In the case of a high quality lens, the wavefront aberration introduced by the lens may be calculated to be approximately one half of that measured in double pass.

In the case of a strongly aberrated microlens, the measurement beam cannot retrace its path through the lens on the second pass and conjugate imagery is not possible. The use of a single path interferometer such as a Mach-Zehnder interferometer, a shearing interferometer or a Shack-Hartmann sensor is recommended in this situation.

However, it is more difficult to test wavefront aberration in small microlenses, where for example the diameter is smaller than 30 micrometres.

The nodal slide bench method is used for focal length testing of conventional lenses but it is difficult to apply to microlenses. The focal length of a microlens is too short and it is also difficult to determine a nodal point physically if the wavefront aberration value is large.

Therefore, the focal length, or more correctly, the effective front or back focal length for a microlens is defined as the distance from the vertex of the microlens to the focus point on the optical axis.

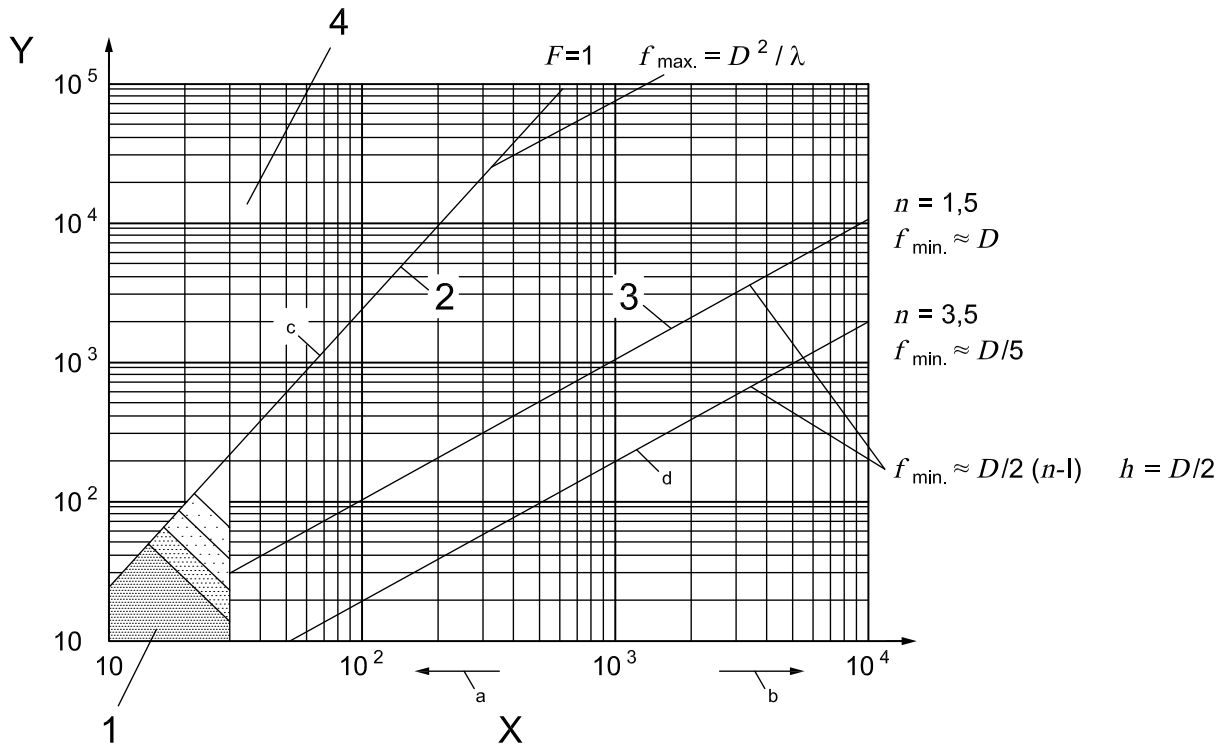

Key

- X lens diameter, D , in μm
- Y focal length, f , in mm
- h surface modulation depth
- n refractive index
- 1 difficult measurement zone for wavefront aberration testing
- 2 diffractive lenses
- 3 refractive lenses
- 4 Fresnel number $F < 1$

- a Microoptics.
- b Macrooptics.
- c Diffraction dominates.
- d NA grows.

Figure A.1 — Feasibility chart for microlenses [22]

Annex B (informative)

Discussion of Annexes to ISO 14880-2, ISO 14880-3 and ISO 14880-4

B.1 Test methods and equipment described in annexes to ISO 14880 series

The microlens array test standards series ISO 14880-2, ISO 14880-3 and ISO 14880-4 contain in their annexes considerable background material about techniques and equipment for testing microlenses and microlens arrays. The main contents of the various sections are listed in Table B.1.

Table B.1 — Annexes to microlens array test standards series ISO 14880-2, ISO 14880-3 and ISO 14880-4

ISO 14880-2:2006:		
Test methods for wavefront aberrations		
	Annex A	Measurement requirements for test methods for microlenses
	Annex B	Microlens test methods 1 and 2 using Mach-Zehnder interferometer systems
	Annex C	Microlens test methods 3 and 4 using a lateral shearing interferometer system
	Annex D	Microlens test method 5 using a Shack-Hartmann sensor system
	Annex E	Microlens array test method 1 using a Twyman-Green interferometer system
	Annex F	Measurement of uniformity of microlens array determined by test method 2
ISO 14880-3:2006:		
Test methods for optical properties other than wavefront aberrations		
	Annex A	Measurements with wavefront measuring systems
	Annex B	Confocal measurement of effective back or front focal length of lens array
	Annex C	Coupling efficiency, imaging quality
	Annex D	Measurement of the uniformity of the focal spot positions of a microlens array
ISO 14880-4:2006:		
Test methods for geometrical properties		
	Annex A	Measurement with a Fizeau interferometer system
	Annex B	Uniformity of array spacing

A list of test equipment referred to in ISO 14880 series is contained in Table B.2.

Table B.2 — Test equipment referred to in Annexes to ISO 14880-2, ISO 14880-3 and ISO 14880-4

Equipment	Feature	Test object	Measurand	Illuminating wavefront geometry	Reference standards
Mach-Zehnder interferometer	conventional air paths	microlens	wavefront aberration	spherical	ISO 14880-2:2006, B.2.1
	air and optical fibre paths	microlens	wavefront aberration	spherical and plane	ISO 14880-2:2006, B.2.2
	computer generated hologram array	microlens array	wavefront aberration	plane	ISO 14880-2:2006, F.3
Michelson interferometer	lateral shearing by mirror tilt	microlens	wavefront aberration, focal length	plane	ISO 14880-2:2006, C.1
Twymann-Green interferometer	double pass	microlens array	wavefront aberration	plane	ISO 14880-2:2006, E.1
Fizeau interferometer	with microscope objective	microlens	focal length	spherical	ISO 14880-3:2006, A.2
	with displacement transducer	microlens	radius of curvature	spherical	ISO 14880-4:2006, A.2
Shack-Hartmann sensor	detects local tilts using lens array and CCD	microlens	wavefront aberration	spherical, fast and slow	ISO 14880-2:2006, D.1
	array detects transverse positions of focal spots	microlens array	uniformity of focal spot positions	plane	ISO 14880-3:2006, D.1
Ronchi grating test	lateral shearing by grating shift	microlens array	wavefront aberration, uniformity	plane	ISO 14880-2:2006, F.2
confocal instrument	double pass, detects light transmitted by confocal aperture	microlens	focal length	plane	ISO 14880-3:2006, B.1
		microlens array	focal length	plane	ISO 14880-3:2006, B.2
alignment stages, camera, reference array	Moiré patterns	lens array	lens spacing	plane	ISO 14880-4:2006, B.1
modulation transfer function	measures contrast in image	microlens	image quality	various	ISO 14880-3:2006, C.2

B.2 Wavefront sensing applied to microlenses

B.2.1 General

ISO 14880 series describes a range of tests applicable to microlenses and microlens arrays. Most techniques use a form of wavefront sensing and the main technique used is interferometry. This section expands on the subject of interferometry and other techniques, applied to testing wavefronts transmitted by microlenses or to testing microlens surfaces.

B.2.2 Interferometry

Wavefront measurements may be made by comparing the test wavefront to a reference surface or wavefront. The reference wavefront may be derived from a reference surface, in which case the test surface may be compared to the reference surface. In some interferometers the reference wavefront is a copy of the

illuminating test wavefront, generated by wavefront division at a beamsplitter. After the test wavefront has traversed the microlens under test it is recombined with the reference wavefront to form an interference pattern.

Various designs of interferometer have evolved and Fizeau, Twyman-Green and Mach-Zehnder interferometers are well known examples. The Fizeau and Twyman-Green interferometers use the same beamsplitter to divide and recombine the wavefronts and the test object may be traversed twice. In the Fizeau interferometer the wavefronts nominally follow a common path. The path lengths differ as the reference wavefront is reflected at the beamsplitter. In the Twyman-Green the path lengths are not common but can be adjusted individually to be of the same length. In the Mach-Zehnder the test object is only traversed once. The beam lengths may be equalised but the paths are different.

In other interferometers such as shearing interferometers, a reference wavefront may be generated from the test wavefront after it has traversed the lens under test. If the reference and test wavefronts undergo a known displacement relative to one another before being recombined, a pattern of fringes is formed that indicates the wavefront slope. This pattern has to be integrated to arrive at the form of the wavefront. In the Ronchi test the wavefront is divided and recombined using special diffraction gratings.

B.2.3 Interferometry applied to microlenses

In ISO 14880 series, special consideration is given to the use of interferometry for testing microlenses. Microlenses have very small aperture diameters, short focal lengths and are often formed with only two surfaces on a relatively thick substrate.

Special measurement requirements are described in ISO 14880-2:2006, Annex A. For example, when using interferometry to measure wavefront aberrations introduced by a microlens, a single pass test is often desirable to avoid spurious reflections. The test devices should not introduce aberrations and components such as beamsplitters should only be used at design conjugates. The user should be aware that a cube or plate beamsplitter may be designed to transmit a plane wavefront and if a spherical wavefront is used the spherical aberration or coma may be introduced.

It is desirable to form a sharp image of the microlens aperture on the detector array as described in ISO 14880-2:2006, Annex C.

B.2.4 Other wavefront sensing techniques

An example of a wavefront sensing technique that does not use interferometry is the Shack-Hartmann test. Here the incident wavefront is divided and focused by an array of small lenses. The relative positions of the focused spots indicate the local tilts of the wavefront at the lenses. The spot positions can be conveniently sensed using a CCD array and the form of the incident wavefront calculated.

The Shack-Hartmann sensor may have a larger dynamic range and be less sensitive to vibration than interferometry. It can measure the wavefront from a low coherence source and optical system in single pass.

However the Shack-Hartmann sensor has a fixed size and it is often necessary to use beam-expanding or contracting optics to fill the sensor.

Confocal sensing is a technique used to increase the sensitivity of location of a particular plane in an image, using a spatial filter to eliminate unwanted light. It can be used to locate the focal point of a microlens and when used with a calibrated stage can be used to measure the focal length of a microlens.

Bibliography

- [1] ISO 10110-5, *Optics and photonics — Preparation of drawings for optical elements and systems — Part 5: Surface form tolerances*
- [2] ISO 10110-14, *Optics and photonics — Preparation of drawings for optical elements and systems — Part 14: Wavefront deformation tolerance*
- [3] ISO 14880-2, *Optics and photonics — Microlens arrays — Part 2: Test methods for wavefront aberrations*
- [4] ISO 14880-3, *Optics and photonics — Microlens arrays — Part 3: Test methods for optical properties other than wavefront aberrations*
- [5] ISO 14880-4, *Optics and photonics — Microlens arrays — Part 4: Test methods for geometrical properties*
- [6] ISO 15529, *Optics and photonics — Optical transfer function — Principles of measurement of modular transfer function (MTF) of sampled imaging systems*
- [7] Hutley M. C., Daly D., Stevens R. F., *The testing of microlens arrays*, Proc. IOP/NPL meeting on microlens arrays, pp 67-81, held at NPL Teddington, May (1991), IOPP Bristol
- [8] Daly D., Hutley M. C.: *Microlens measurement at NPL*, Proc IOP/NPL meeting microlens arrays pp 50 – 54 held at NPL Teddington, May (1993)
- [9] Yingen Gao, Hutley M. C., *Chromatic dispersion of microlenses. Proc IOP/NPL meeting microlens arrays*, pp 65-69, held at NPL Teddington, May (1995)
- [10] Schwider J., Falkenstorfer O., *Twymann-Green interferometer for testing microspheres*, Proc IOP/NPL meeting Microlens arrays, pp 60-64, held at NPL Teddington, May (1995)
- [11] Iga K., Kokubun Y., Oikawa M., *Fundamentals of microoptics*. Academic Press, New York (1984)
- [12] Borrelli N., *Microoptics Technology. Fabrication and applications of lens arrays and devices*. Marcel Dekker, Inc. New York (1999)
- [13] Born M., Wolf E., *Principles of Optics, Electromagnetic theory of propagation, interference and diffraction of light*. Cambridge University Press (1999)
- [14] Tiziani H. J., Haist T., Reuter S: *Optical inspection and characterisation of microoptics using confocal microscopy*, *Optics and lasers in engineering*. **36**, pp 403-415 (2001)
- [15] Sickinger H., Schwider J. and Manzke B., *Fiber based Mach-Zehnder interferometer for measuring wave aberrations of microlenses*, *Optik*, **110**, pp 239-243 (1999)
- [16] Takaaki Miyashita, Kenjiro Hamanaka, Masahiko Kato, Satoshi Ishihara, Hiroyasu Sato, Eiichi Sato, and Tadashi Morokuma: *Wavefront aberration measurement technology for microlens using the Mach-Zehnder interferometer provided with a projected aperture*, Proc. SPIE, **5532**, pp117-127, (2004)
- [17] Masahiko Kato, Takaaki Miyashita, Kenjiro Hamanaka, Satoshi Ishihara, Eiichi Sato, and Tadashi Morokuma: *Equivalence between the software determined and the hardware determined effective numerical aperture in the interferometrical measuring of microlens*, Proc. SPIE, **5532**, pp 136-146 (2004)
- [18] Takaaki Miyashita, *Standardization for Microlens and Microlens Arrays*, Japanese Journal of Applied Physics (JJAP), **46**, No. 8B, pp. 5391-5396 (2007)

- [19] Geary JM. *Introduction to Wavefront Sensors*. SPIE Vol TT18. Bellingham USA (1995)
- [20] Singer W, Dobler B, Schreiber H, Brenner K, Messerschmidt B: *Refractive-index measurement of gradient-index microlenses by diffraction tomography*,. *Applied Optics* **35**, pp 2167-2171 (1996)
- [21] Goring R, Rothhardt M: *Application of the refracted near-field technique to multimode planar and channel waveguides in glass*, *Journal of Optical Communications* **7**, pp 82-85 (1986)
- [22] J. Schwider, H. Sickinger: *Array tests for microlenses*, *Optik*, 107 No.1 pp 26-34 (1997)
- [23] Joerg Karger, Ulf Schemmert, Sergey Vasekov, "*Application of interference microscopy - a novel route to study intracrystalline zeolitic diffusion*", *Adsorption Science and Technology Proceedings of the Second Pacific Basin Conference Brisbane, Australia, 14 - 18 May 2000*

