

INTERNATIONAL STANDARD

ISO
7721-2

First edition
1990-09-01

Countersunk flat head screws —

Part 2:

Penetration depth of cross recesses

Vis à métaux à tête fraisée —

Partie 2: Profondeur de pénétration des empreintes cruciformes



Reference number
ISO 7721-2:1990(E)

Foreword

ISO (the International Organization for Standardization) is a worldwide federation of national standards bodies (ISO member bodies). The work of preparing International Standards is normally carried out through ISO technical committees. Each member body interested in a subject for which a technical committee has been established has the right to be represented on that committee. International organizations, governmental and non-governmental, in liaison with ISO, also take part in the work. ISO collaborates closely with the International Electrotechnical Commission (IEC) on all matters of electrotechnical standardization.

Draft International Standards adopted by the technical committees are circulated to the member bodies for voting. Publication as an International Standard requires approval by at least 75 % of the member bodies casting a vote.

International Standard ISO 7721-2 was prepared by Technical Committee ISO/TC 2, *Fasteners*.

ISO 7721 consists of the following parts, under the general title *Countersunk flat head screws*:

- *Part 1: Head configuration and gauging*
- *Part 2: Penetration depth of cross recesses*

Annex A of this part of ISO 7721 is for information only.

Introduction

The penetration depth of cross recesses for countersunk flat head screws has to satisfy two requirements which act in opposite directions for a given head dimension.

First, there is the requirement for sufficient head strength to attain the proof and breaking loads of the respective property class. A shallow cross recess increases the head strength. On the other hand, the wrenchability of the screw should be satisfactory; this can only be achieved by a sufficiently deep cross recess.

ISO 7721-2 was developed in order to find a compromise which, as far as possible, would meet both requirements.

This part of ISO 7721 specifies deep cross recesses for countersunk head screws of low strength: a good wrenchability is achieved and the head strength is still sufficient. This execution will be used in ISO 7046-1 (see annex A).

For screws of higher strength, sufficient head strength can only be attained by a shallower penetration depth of the cross recesses. If such screws also require good wrenchability, then, under the conditions of the common head style, a shoulder has to be provided under the head, in addition to the larger penetration depth, in order to guarantee sufficient head strength.

This compromise, which unfortunately results in different but interchangeable types of cross recessed flat countersunk head screws, is at the moment the only way of reaching an agreement at the international level.

This page intentionally left blank

Countersunk flat head screws —

Part 2: Penetration depth of cross recesses

1 Scope

This part of ISO 7721 specifies the penetration depth of cross recesses of countersunk flat head screws for the two series 1 and 2 (deep and shallow, respectively).

2 Normative references

The following standards contain provisions which, through reference in this text, constitute provisions of this part of ISO 7721. At the time of publication, the editions indicated were valid. All standards are subject to revision, and parties to agreements based on this part of ISO 7721 are encouraged to investigate the possibility of applying the most recent editions of the standards indicated below. Members of IEC and ISO maintain registers of currently valid International Standards.

ISO 225:1983, *Fasteners — Bolts, screws, studs and nuts — Symbols and designations of dimensions.*

ISO 4757:1983, *Cross recesses for screws.*

ISO 7721:1983, *Countersunk head screws — Head configuration and gauging.*

3 Dimensions

For application of the penetration depths of cross recesses specified in table 1, different underhead configurations are provided in order to attain sufficient head strength (see figure 1 and figure 2). Both types satisfy the conditions of the common head style as specified in ISO 7721¹⁾.

NOTE 1 Symbols and designations of dimensions are specified in ISO 225.

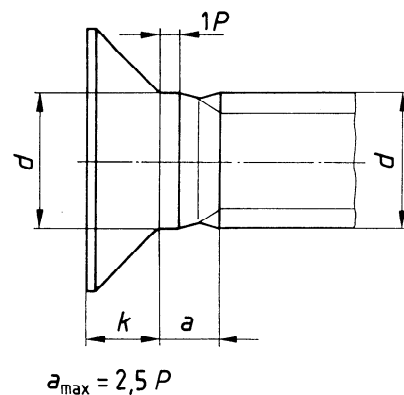

Figure 1 — Screw with underhead shoulder

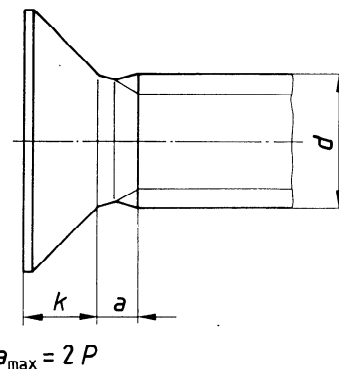

Figure 2 — Screw without underhead shoulder

1) Will be revised and published under number ISO 7721-1

Table 1 — Dimensions

Dimensions in millimetres

Thread (d)		Recess No. 1)	Cross recesses											
			Series 1 (deep)						Series 2 (shallow)					
Metric	Other		Type H			Type Z			Type H			Type Z		
			Penetration depth ²⁾		m	Penetration depth ²⁾		m	Penetration depth ²⁾		m	Penetration depth ²⁾		m
			min.	max.	ref.	min.	max.	ref.	min.	max.	ref.	min.	max.	ref.
M1,6	—	0	0,6	0,9	1,6	0,70	0,95	1,6	—	—	—	—	—	—
M2	—	0	0,9	1,2	1,9	0,95	1,20	1,9	0,9	1,2	1,9	0,95	1,20	1,9
—	ST2,2	0	0,9	1,2	1,9	0,95	1,20	2	—	—	—	—	—	—
M2,5	—	1	1,4	1,8	2,9	1,48	1,73	2,8	1,25	1,55	2,7	1,22	1,47	2,5
M3	ST2,9	1	1,7	2,1	3,2	1,76	2,01	3	1,4	1,8	2,9	1,48	1,73	2,8
M3,5	ST3,5	2	1,9	2,4	4,4	1,75	2,20	4,1	1,6	2,1	4,1	1,61	2,05	4
M4	ST4,2	2	2,1	2,6	4,6	2,06	2,51	4,4	2,1	2,6	4,6	2,06	2,51	4,4
M5	ST4,8	2	2,7	3,2	5,2	2,60	3,05	4,9	2,3	2,8	4,8	2,27	2,72	4,6
—	ST5,5	3	2,8	3,3	6,6	2,73	3,18	6,3	—	—	—	—	—	—
M6	ST6,3	3	3,0	3,5	6,8	3,00	3,45	6,6	2,8	3,3	6,6	2,73	3,18	6,3
M8	ST8	4	4,0	4,6	8,9	4,15	4,60	8,8	3,9	4,4	8,7	3,87	4,32	8,5
M10	ST9,5	4	5,1	5,7	10	5,19	5,64	9,8	4,8	5,3	9,6	4,78	5,23	9,4
Application ³⁾			Screws without underhead shoulder Self-tapping screws Wood screws Screws of property class 4.8						Screws without underhead shoulder					
			Screws with underhead shoulder Screws of property classes 8.8 and 9.8 Thread cutting screws Thread forming screws						Screws of property class 8.8 Thread forming screws Thread cutting screws } entirely heat treated					

1) Cross recesses in accordance with ISO 4757.

2) Penetration depth measured in accordance with ISO 4757.

3) Specified for steel screws, application for other materials at manufacturer's option.

Annex A
(informative)

Bibliography

- [1] ISO 7046:1983, *Cross recessed countersunk flat head screws (common head style) — Product grade A and property class 4.8 only.*²⁾
- [2] ISO 7046-2:1990, *Cross recessed countersunk flat head screws (common head style) — Grade A — Part 2: Steel of property class 8.8, stainless steel and non-ferrous metals.*
-

²⁾ Will be revised and published under number ISO 7046-1.

UDC 621.882.215.6.091.6

Descriptors: fasteners, screws, countersunk head screws, cross recessed screws, dimensions.

Price based on 3 pages
