**Plastics — Determination of the
melt mass-flow rate (MFR) and
melt volume-flow rate (MVR) of
thermoplastics —**

**Part 1:
Standard method**

*Plastiques — Détermination de l'indice de fluidité à chaud des
thermoplastiques, en masse (MFR) et en volume (MVR) —*

Partie 1: Méthode normale





COPYRIGHT PROTECTED DOCUMENT

© ISO 2022

All rights reserved. Unless otherwise specified, or required in the context of its implementation, no part of this publication may be reproduced or utilized otherwise in any form or by any means, electronic or mechanical, including photocopying, or posting on the internet or an intranet, without prior written permission. Permission can be requested from either ISO at the address below or ISO's member body in the country of the requester.

ISO copyright office
CP 401 • Ch. de Blandonnet 8
CH-1214 Vernier, Geneva
Phone: +41 22 749 01 11
Email: copyright@iso.org
Website: www.iso.org

Published in Switzerland

Contents

	Page
Foreword.....	v
Introduction.....	vi
1 Scope.....	1
2 Normative references.....	1
3 Terms and definitions.....	1
4 Principle.....	2
5 Apparatus.....	3
5.1 Extrusion plastometer.....	3
5.2 Accessory equipment.....	7
5.2.1 General.....	7
5.2.2 Equipment for procedure A (see Clause 8).....	8
5.2.3 Equipment for procedure B (see Clause 9): Piston displacement transducer/ timer.....	8
6 Test sample.....	8
6.1 Sample form.....	8
6.2 Conditioning.....	9
7 Temperature verification, cleaning and maintenance of the apparatus.....	9
7.1 Verification of the temperature control system.....	9
7.1.1 Verification procedure.....	9
7.1.2 Material used during temperature verification.....	10
7.2 Cleaning the apparatus.....	10
7.3 Vertical alignment of the instrument.....	10
8 Procedure A: mass-measurement method.....	10
8.1 Selection of temperature and load.....	10
8.2 Cleaning.....	11
8.3 Selection of sample mass and charging the cylinder.....	11
8.4 Measurements.....	12
8.5 Expression of results.....	13
8.5.1 General.....	13
8.5.2 Expression of results: standard die.....	13
8.5.3 Expression of results: half size die.....	13
9 Procedure B: displacement-measurement method.....	14
9.1 Selection of temperature and load.....	14
9.2 Cleaning.....	14
9.3 Minimum piston displacement distance.....	14
9.4 Selection of sample mass and charging the cylinder.....	14
9.5 Measurements.....	14
9.6 Expression of results.....	15
9.6.1 General.....	15
9.6.2 Expression of results: standard die.....	15
9.6.3 Expression of results: half size die.....	16
10 Flow rate ratio.....	16
11 Precision.....	17
12 Test report.....	17
Annex A (normative) Test conditions for MFR and MVR determinations.....	19
Annex B (informative) Conditions specified in International Standards for the determination of the melt flow rate of thermoplastic materials.....	21

Annex C (informative) Device and procedure for performing a compacted charge of material by compression	22
Annex D (informative) Precision data for polypropylene obtained from an intercomparison of MFR and MVR testing	25
Bibliography	26

Foreword

ISO (the International Organization for Standardization) is a worldwide federation of national standards bodies (ISO member bodies). The work of preparing International Standards is normally carried out through ISO technical committees. Each member body interested in a subject for which a technical committee has been established has the right to be represented on that committee. International organizations, governmental and non-governmental, in liaison with ISO, also take part in the work. ISO collaborates closely with the International Electrotechnical Commission (IEC) on all matters of electrotechnical standardization.

The procedures used to develop this document and those intended for its further maintenance are described in the ISO/IEC Directives, Part 1. In particular, the different approval criteria needed for the different types of ISO documents should be noted. This document was drafted in accordance with the editorial rules of the ISO/IEC Directives, Part 2 (see www.iso.org/directives).

Attention is drawn to the possibility that some of the elements of this document may be the subject of patent rights. ISO shall not be held responsible for identifying any or all such patent rights. Details of any patent rights identified during the development of the document will be in the Introduction and/or on the ISO list of patent declarations received (see www.iso.org/patents).

Any trade name used in this document is information given for the convenience of users and does not constitute an endorsement.

For an explanation of the voluntary nature of standards, the meaning of ISO specific terms and expressions related to conformity assessment, as well as information about ISO's adherence to the World Trade Organization (WTO) principles in the Technical Barriers to Trade (TBT), see www.iso.org/iso/foreword.html.

This document was prepared by Technical Committee ISO/TC 61, *Plastics*, Subcommittee SC 5, *Physical-chemical properties*, in collaboration with the European Committee for Standardization (CEN) Technical Committee CEN/TC 249, *Plastics*, in accordance with the Agreement on technical cooperation between ISO and CEN (Vienna Agreement).

This second edition cancels and replaces the first edition (ISO 1133-1:2011), of which it constitutes a minor revision. The changes are as follows:

- references to withdrawn standards in [Annex B](#) (informative), [Annex D](#) (informative) and Bibliography have been updated;
- editorial corrections.

A list of all parts in the ISO 1133 series can be found on the ISO website.

Any feedback or questions on this document should be directed to the user's national standards body. A complete listing of these bodies can be found at www.iso.org/members.html.

Introduction

For stable materials that are not rheologically sensitive to the time-temperature history experienced during melt flow rate testing, this document is recommended.

For materials whose rheological behaviour is sensitive to the test's time-temperature history, e.g. materials which degrade during the test, ISO 1133-2 is recommended. Also, ISO 1133-2 is considered to be particularly relevant for moisture-sensitive plastics.

NOTE At the time of publication, there is no evidence to suggest that the use of ISO 1133-2 for stable materials results in better precision in comparison with the use of this document.

Plastics — Determination of the melt mass-flow rate (MFR) and melt volume-flow rate (MVR) of thermoplastics —

Part 1: Standard method

WARNING — Persons using this document should be familiar with normal laboratory practice, if applicable. This document does not purport to address all of the safety problems, if any, associated with its use. It is the responsibility of the user to establish appropriate safety and health practices and to ensure compliance with any regulatory requirements.

1 Scope

This document specifies two procedures for the determination of the melt mass-flow rate (MFR) and the melt volume-flow rate (MVR) of thermoplastic materials under specified conditions of temperature and load. Procedure A is a mass-measurement method. Procedure B is a displacement-measurement method. Normally, the test conditions for measurement of melt flow rate are specified in the material standard with a reference to this document. The test conditions normally used for thermoplastics are listed in [Annex A](#).

The MVR is particularly useful when comparing materials of different filler content and when comparing filled with unfilled thermoplastics. The MFR can be determined from MVR measurements, or vice versa, provided the melt density at the test temperature is known.

This document is also possibly applicable to thermoplastics for which the rheological behaviour is affected during the measurement by phenomena such as hydrolysis (chain scission), condensation and cross-linking, but only if the effect is limited in extent and only if the repeatability and reproducibility are within an acceptable range. For materials which show significantly affected rheological behaviour during testing, this document is not appropriate. In such cases, ISO 1133-2 applies.

NOTE The rates of shear in these methods are much smaller than those used under normal conditions of processing, and therefore it is possible that data obtained by these methods for various thermoplastics will not always correlate with their behaviour during processing. Both methods are used primarily in quality control.

2 Normative references

There are no normative references in this document.

3 Terms and definitions

For the purposes of this document, the following terms and definitions apply.

ISO and IEC maintain terminology databases for use in standardization at the following addresses:

- ISO Online browsing platform: available at <https://www.iso.org/obp>
- IEC Electropedia: available at <https://www.electropedia.org/>

3.1
melt mass-flow rate
MFR

rate of extrusion of a molten resin through a die of specified length and diameter under prescribed conditions of temperature, load and piston position in the cylinder of an extrusion plastometer, the rate being determined as the mass extruded over a specified time

Note 1 to entry: MFR is expressed in units of grams per 10 min. Alternative units accepted by SI are decigrams per minute, where 1 g/10 min is equivalent to 1 dg/min.

3.2
melt volume-flow rate
MVR

rate of extrusion of a molten resin through a die of specified length and diameter under prescribed conditions of temperature, load and piston position in the cylinder of an extrusion plastometer, the rate being determined as the volume extruded over a specified time

Note 1 to entry: MVR is expressed in units of cubic centimetres per 10 min.

3.3
load

combined force exerted by the mass of the piston and the added weight, or weights, as specified by the conditions of the test

Note 1 to entry: Load is expressed as the mass, in kilograms, exerting it.

3.4
preformed compacted charge
test sample prepared as a compressed charge of polymer sample

Note 1 to entry: In order to introduce samples quickly into the bore of the cylinder and to ensure void-free extrudate, it may be necessary to preform samples originally in the form of, for example, powders or flakes into a compacted charge.

3.5
time-temperature history

history of the temperature and time to which the sample is exposed during testing including sample preparation

3.6
standard die
die having a nominal length of 8,000 mm and a nominal bore diameter of 2,095 mm

3.7
half size die
die having a nominal length of 4,000 mm and a nominal bore diameter of 1,050 mm

3.8
moisture-sensitive plastics
plastics having rheological properties that are sensitive to their moisture content

Note 1 to entry: Plastics which, when containing absorbed water and heated above their glass transition temperatures (for amorphous plastics) or melting point (for semi-crystalline plastics), undergo hydrolysis resulting in a reduction in molar mass and consequently a reduction in melt viscosity and an increase in MFR and MVR.

4 Principle

The melt mass-flow rate (MFR) and the melt volume-flow rate (MVR) are determined by extruding molten material from the cylinder of a plastometer through a die of specified length and diameter under preset conditions of temperature and load.

For measurement of MFR (procedure A), timed segments of the extrudate are weighed and used to calculate the extrusion rate, in grams per 10 min.

For measurement of MVR (procedure B), the distance that the piston moves in a specified time or the time required for the piston to move a specified distance is recorded and used to calculate the extrusion rate in cubic centimetres per 10 min.

MVR can be converted to MFR, or vice versa, if the melt density of the material at the test temperature is known.

NOTE The density of the melt is required at the test temperature and pressure. In practice, the pressure is low and values obtained at the test temperature and ambient pressure suffice.

5 Apparatus

5.1 Extrusion plastometer

5.1.1 General. The basic apparatus comprises an extrusion plastometer operating at a fixed temperature. The general design is as shown in [Figure 1](#). The thermoplastic material, which is contained in a vertical cylinder, is extruded through a die by a piston loaded with a known weight. The apparatus consists of the following essential parts.

5.1.2 Cylinder. The cylinder shall have a length between 115 mm and 180 mm and an internal diameter of $(9,550 \pm 0,007)$ mm and shall be fixed in a vertical position (see [5.1.6](#)).

The cylinder shall be manufactured from a material resistant to wear and corrosion up to the maximum temperature of the heating system. The bore shall be manufactured using techniques and materials that produce a Vickers hardness of no less than 500 (HV 5 to HV 100) (see ISO 6507-1) and shall be manufactured by a technique that produces a surface roughness of less than R_a (arithmetical mean deviation) equal to $0,25 \mu\text{m}$ (see ISO 21920-2). The finish, properties and dimensions of its surface shall not be affected by the material being tested.

NOTE 1 For particular materials, it is possible that measurements will be required at temperatures up to $450 \text{ }^\circ\text{C}$.

The base of the cylinder shall be thermally insulated in such a way that the area of exposed metal is less than 4 cm^2 , and it is recommended that an insulating material such as Al_2O_3 , ceramic fibre or another suitable material be used in order to avoid sticking of the extrudate.

A piston guide or other suitable means of minimizing friction due to misalignment of the piston shall be provided.

NOTE 2 Excessive wear of the piston head, piston and cylinder and erratic results can be indications of misalignment of the piston. Regular visual checking for wear and change to the surface appearance of the piston head, piston and cylinder is recommended.

5.1.3 Piston. The piston shall have a working length at least as long as the cylinder. The piston shall have a head $(6,35 \pm 0,10)$ mm in length. The diameter of the head shall be $(9,474 \pm 0,007)$ mm. The lower

edge of the piston head shall have a radius of $(0,4^{0,0}_{-0,1})$ mm and the upper edge shall have its sharp edge removed. Above the head, the piston shall be relieved to $\leq 9,0$ mm diameter (see [Figure 2](#)).

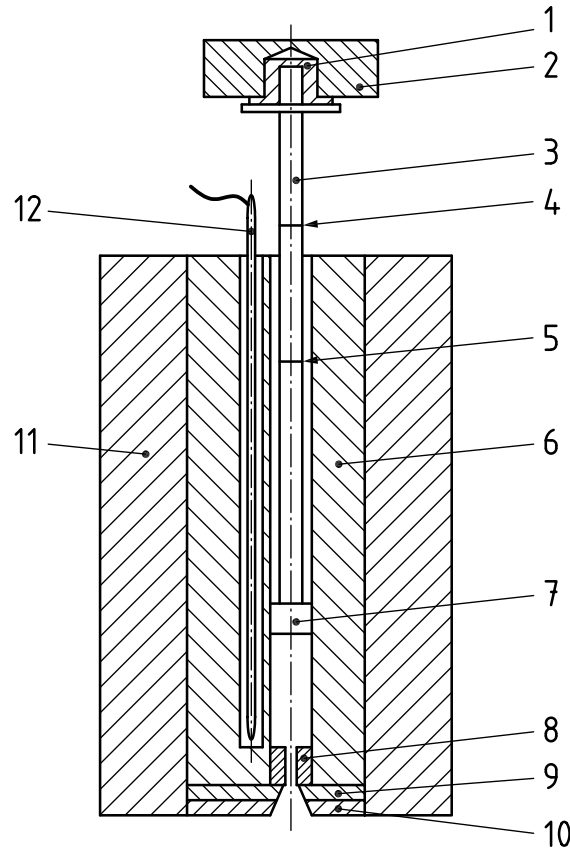

Key

- 1 insulation
- 2 removable weight
- 3 piston
- 4 upper reference mark
- 5 lower reference mark
- 6 cylinder
- 7 piston head
- 8 die
- 9 die retaining plate
- 10 insulating plate
- 11 insulation
- 12 temperature sensor

Figure 1 — Typical apparatus for determining melt flow rate, showing one possible configuration

The piston shall be manufactured from a material resistant to wear and corrosion up to the maximum temperature of the heating system, and its properties and dimensions shall not be affected by the material being tested. To ensure satisfactory operation of the apparatus, the cylinder and the piston head shall be made of materials of different hardness. It is convenient for ease of maintenance and renewal to make the cylinder of the harder material.

Along the piston stem, two thin annular reference marks shall be scribed ($30 \pm 0,2$) mm apart and so positioned that the upper mark is aligned with the top of the cylinder when the distance between the lower edge of the piston head and the top of the standard die is 20 mm. These annular marks on the piston are used as reference points during the measurements (see 8.4 and 9.5).

A stud may be added at the top of the piston to position and support the removable weights, but the piston shall be thermally insulated from the weights.

The piston may be either hollow or solid. In tests with very low loads the piston may need to be hollow, otherwise it may not be possible to obtain the lowest prescribed load.

Table 1 — Dimensions of piston head

Dimensions in millimetres

Length of head, A	$6,35 \pm 0,10$
Diameter of head, B	$9,474 \pm 0,007$
Diameter of stem, C	$\leq 9,0$
Radius of lower edge, R	$0,4^{0,0}_{-0,1}$

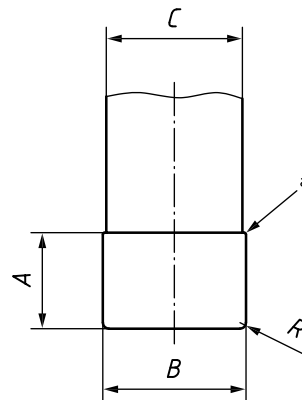

Key

- A length of head
- B diameter of head
- C diameter of stem
- R radius of lower edge
- a Sharp edge removed.

Figure 2 — Schematic of piston head

5.1.4 Temperature-control system. For all cylinder temperatures that can be set, the temperature control shall be such that between (10 ± 1) mm and (70 ± 1) mm above the top of the standard die, the temperature differences measured do not exceed those given in Table 2 throughout the duration of the test.

NOTE The temperature can be measured and controlled with, for example, thermocouples or platinum-resistance sensors embedded in the wall of the cylinder. If the apparatus is equipped in this way, it is possible that the temperature is not exactly the same as that in the melt, but the temperature-control system can be calibrated (see 7.1) to read the in-melt temperature.

The temperature-control system shall allow the test temperature to be set in steps of $0,1$ °C or less.

Table 2 — Maximum allowable deviation from required test temperature with distance and with time over the duration of the test

Temperatures in degrees Celsius

Test temperature <i>T</i>	Maximum permitted deviation from the required test temperature: ^a	
	at (10 ± 1) mm above the top surface of the standard die ^b	from (10 ± 1) mm to (70 ± 1) mm above the top surface of the standard die ^b
125 ≤ <i>T</i> < 250	±1,0 ^c	±2,0
250 ≤ <i>T</i> < 300	±1,0 ^c	±2,5
300 ≤ <i>T</i>	±1,0	±3,0

^a The maximum permitted deviation from the required test temperature is the difference between the true value of temperature and the required test temperature. It shall be assessed over the normal duration of a test, typically less than 25 min.

^b When using a 4 mm length half size die (see 5.1.5), the readings shall be made an additional 4 mm above the top surface of the die.

^c For test temperatures < 300 °C, the temperature at 10 mm above the top surface of the die shall not vary with time by greater than 1 °C in range.

5.1.5 Die. The die shall be made of tungsten carbide or hardened steel. For testing potentially corrosive materials, dies made of cobalt-chromium-tungsten alloy, chromalloy, synthetic sapphire or other suitable materials may be used.

The die shall be (8,000 ± 0,025) mm in length. The interior of the bore shall be manufactured circular, straight and uniform in diameter such that in all positions it is within ± 0,005 mm of a true cylinder of diameter 2,095 mm.

The bore shall be hardened by a technique that produces a Vickers hardness of no less than 500 (HV 5 to HV 100) (see ISO 6507-1) and shall be manufactured by a technique that produces a surface roughness of less than *Ra* (arithmetical mean deviation) = 0,25 µm (see ISO 21920-2).

The bore diameter shall be checked regularly with a go/no-go gauge. If outside the tolerance limits, the die shall be discarded. If the no-go gauge enters the bore to any extent the die shall be discarded.

The die shall have ends that are flat, perpendicular to the axis of the bore and free from visible machining marks. The flat surfaces of the die shall be checked to ensure that the area around the bore is not chipped. Any chipping causes errors and chipped dies shall be discarded.

The die shall have an outside diameter such that it moves freely within the cylinder, but that there is no flow of material along its outside, i.e. between the die and the cylinder, during the test.

The die shall not project beyond the base of the cylinder (see Figure 1) and shall be mounted so that its bore is co-axial with the cylinder bore.

If testing materials with an MFR > 75 g/10 min or an MVR > 75 cm³/10 min, a half size die of length (4,000 ± 0,025) mm and bore diameter (1,050 ± 0,005) mm may be used. No spacer shall be used in the cylinder below this die to increase the apparent length to 8,000 mm.

The die of nominal length 8,000 mm and bore of nominal internal diameter 2,095 mm is taken to be the standard die for use in testing. When reporting MFR and MVR values obtained using a half size die, it shall be stated that a half size die was used.

5.1.6 Means of setting and maintaining the cylinder vertical. A two-directional bubble level, set normal to the cylinder axis, and adjustable supports for the apparatus are suitable for the purpose.

NOTE This is to avoid excessive friction caused by the piston leaning to one side or bending under heavy loads. A dummy piston with a spirit level on its upper end is also a suitable means of checking conformity with this requirement.

5.1.7 Load. A set of removable weights, selected so that the combined mass of the weights and the piston gives the required load to within a maximum permissible error of $\pm 0,5\%$, are mounted on top of the piston.

Alternatively, a mechanical loading device combined with a load cell or a pneumatic loading device with a pressure sensor, providing the same level of accuracy as the removable weights, may be used.

5.2 Accessory equipment

5.2.1 General

5.2.1.1 Packing rod, made of non-abrasive material, for introducing test samples into the cylinder.

5.2.1.2 Cleaning equipment (see [7.2](#)).

5.2.1.3 Go/no-go gauge, one end having a pin with a diameter equal to that of the die bore minus the allowed tolerance (go gauge) and the opposite end having a pin with a diameter equal to that of the die bore plus the allowed tolerance (no-go gauge). The pin gauge shall be sufficiently long to check the full length of the die using the go gauge.

5.2.1.4 Temperature-calibration device (thermocouple, platinum-resistance thermometer or other temperature-measuring device) for calibration of the cylinder temperature-indicating device.

A light-gauge probe-type temperature-measuring device that has a short sensing length and which is calibrated at the temperatures and immersion lengths that are to be used when calibrating the cylinder temperature may be used. The length of the temperature calibration device shall be sufficient to measure the temperature at (10 ± 1) mm from the top of the die. The temperature calibration device shall have sufficient accuracy and precision to enable verification of the MVR/MFR instrument to within the maximum permissible errors in temperature as specified in [Table 2](#). When used, the thermocouple should be encased in a metallic sheath having a diameter of approximately 1,6 mm with its hot junction grounded to the end of the sheath.

An alternative technique for verification is to use a sheathed thermocouple or platinum-resistance temperature sensor inserted into a bronze tip with a diameter of $(9,4 \pm 0,1)$ mm for insertion in the bore without material present. The tip shall be designed so that it holds the sensing point of the thermocouple or platinum-resistance temperature sensor (10 ± 1) mm from the top surface of the standard die when it rests directly on top of the die.

A further alternative is to use a rod fitted with thermocouples that would allow it to be used to make simultaneous temperature determinations at (70 ± 1) mm, (50 ± 1) mm, (30 ± 1) mm and (10 ± 1) mm above the top of the standard die. The rod shall be $(9,4 \pm 0,1)$ mm in diameter so that it fits tightly in the bore.

5.2.1.5 Die plug. A device shaped at one end so that it effectively blocks the die exit and prevents drool of molten material while allowing rapid removal prior to initiation of the test.

5.2.1.6 Piston/weight support, of sufficient length to hold the piston, and weights as necessary, so that the lower reference mark is 25 mm above the top of the cylinder.

5.2.1.7 Preforming device. A device for preforming samples, e.g. powders, flakes, film strips or fragments, into a compacted charge, thereby allowing quick introduction of the charge into the cylinder and to ensure void-free filling of the cylinder (see [Annex C](#)).

NOTE It is possible that there are other options to achieve void-free filling of the cylinder.

5.2.2 Equipment for procedure A (see [Clause 8](#))

5.2.2.1 Cutting tool, for cutting the extruded sample.

NOTE A sharp-edge spatula or a rotating cutter blade with either manual operation or motor drive has been found to be suitable.

5.2.2.2 Timer, with sufficient accuracy to enable cutting of the extruded samples with a maximum permissible error of ± 1 % of the cut-off time interval used. For verification, compare the cut-off time intervals with a calibrated timing device over different time intervals of up to 240 s.

NOTE MFRs < 5 g/10 min can be measured with the maximum allowed cutting time interval of 240 s. In this case, the maximum permissible error for the cutting time is $\pm 2,4$ s. Shorter intervals are allowed, but lead to smaller maximum permissible errors. MFRs > 10 g/10 min require cutting times in the order of a few seconds or less. For 1 s, the required maximum permissible error of the cutting time is $\pm 0,01$ s or better. Automatic cutters are recommended for MFR values greater than 10 g/10 min.

Where the timing device makes physical contact with the piston or weight, the load shall not be altered by more than $\pm 0,5$ % of the nominal load.

5.2.2.3 Balance, with a maximum permissible error of ± 1 mg or better.

5.2.3 Equipment for procedure B (see [Clause 9](#)): Piston displacement transducer/timer

This equipment measures distance and time for the piston movement, using single or multiple determinations for a single charge (see [Table 3](#)).

Table 3 — Piston distance and time measurement accuracy requirements

MFR (g/10 min) MVR (cm ³ /10 min) ^a	Distance	Time
	mm	s
0,1 to 1,0	$\pm 0,02$	$\pm 0,1$
$> 1,0$ to 100	$\pm 0,1$	$\pm 0,1$
> 100	$\pm 0,1$	$\pm 0,01$

^a For multiple measurements using a single charge regardless of the MFR or MVR of the material, the requirements shall be the same as for MFR > 100 g/10 min or MVR > 100 cm³/10 min.

NOTE Compliance with distance accuracy requirements for MFR ≤ 1 g/10 min and MVR ≤ 1 cm³/10 min also ensures compliance for MFR > 1 g/10 min and MVR > 1 cm³/10 min.

Where the displacement measurement device makes physical contact with the piston or weight, the load shall not be altered by more than $\pm 0,5$ % of the nominal load.

Where the timing device makes physical contact with the piston or weight, the load shall not be altered by more than $\pm 0,5$ % of the nominal load.

6 Test sample

6.1 Sample form

The test sample may be in any form that can be introduced into the bore of the cylinder, e.g. granules, strips of film, powder or sections of moulded or extruded parts.

NOTE In order to ensure void-free extrudates when testing powders, it can prove necessary to first compress the material into a preform or pellets. [Annex C](#) provides further information on a preparation method for a preformed compacted charge.

The form of the test sample can be a significant factor in determining the reproducibility of results. The form of the test sample should therefore be controlled to improve the comparability of inter-laboratory results and to reduce the variability between runs.

6.2 Conditioning

The test sample shall be conditioned and, if considered necessary, stabilized prior to testing in accordance with the appropriate material standard.

7 Temperature verification, cleaning and maintenance of the apparatus

7.1 Verification of the temperature control system

7.1.1 Verification procedure

It is necessary to verify regularly the performance of the temperature-control system (5.1.4). Verify that the temperature over time as well as distance conforms to the requirements stated in Table 2, and that the pre-heat time (8.3) is sufficient to obtain stabilization.

Set the temperature-control system on the MFR/MVR instrument to the required temperature and allow it to stabilize for not less than 15 min.

It is preferable to preheat the calibrated temperature-indicating device to the same temperature as that being measured prior to its insertion into the cylinder.

If the cylinder temperature is to be verified using material in the cylinder, charge the cylinder within a period of 15 s up to at least 100 mm above the top of the standard die with the material to be tested or a material representative thereof (see 7.1.2), using the same technique as for a test (see 8.3).

Within 90 s after completing the charging of the material, introduce the calibrated temperature-indicating device (5.2.1.4) along the wall into the cylinder, immersing it in the material therein until the sensor is (10 ± 1) mm above the top surface of the standard die. Immediately, start recording the temperature indicated by the calibrated temperature-indicating device. Determine the time taken from completion of charging until the temperature has stabilized to within the temperature limits specified in Table 2 for (10 ± 1) mm above the top surface of the standard die. This time period shall not be greater than 5 min.

The temperature profile along the cylinder shall be verified similarly. For this, measure the temperatures of the material also at (30 ± 1) mm, (50 ± 1) mm and (70 ± 1) mm above the top surface of the standard die. Determine the time taken from completion of charging until the temperature has stabilized to within the temperature limits specified in Table 2 for between (10 ± 1) mm to (70 ± 1) mm above the top surface of the standard die. This time period shall not be greater than 5 min.

If the time to reach temperature stabilization to within the temperature limits specified in Table 2 is longer than 5 min at any of the set distances above the top surface of the die, this shall be recorded in the test report under item f) "pre-heating time".

It is recommended that when verifying the temperature profile along the cylinder, the measurements are started at the highest point above the die.

An alternative technique for verification of the temperature accuracy to within the specification of Table 2 is to use a sheathed thermocouple or platinum-resistance temperature sensor with tip diameter of $(9,4 \pm 0,1)$ mm for insertion in the cylinder without material present. Another technique is to use a piston fitted with thermocouples at heights of (70 ± 1) mm, (50 ± 1) mm, (30 ± 1) mm and (10 ± 1) mm above the top surface of the standard die when inserted completely into the cylinder and which fits the bore closely. This configuration allows simultaneous verification of the temperature with both time and distance.

If the instrument is found to be out of specification ([Table 2](#)) then it shall be re-calibrated and verified prior to use.

7.1.2 Material used during temperature verification

It is essential that the material used during verification be sufficiently fluid to permit the calibrated temperature-measuring device to be introduced without excessive force or risk of damage. A stable material with an MFR of greater than 45 g/10 min (2,16 kg load) at the verification temperature has been found suitable.

If such a material is used for verification purposes in place of a more viscous material that is to be tested, the dummy material shall have a thermal diffusivity similar to that of the material to be tested, so that warm-up behaviour is similar. It is necessary that the quantity charged for verification be such that, when the calibrated temperature sensor is subsequently introduced, the appropriate length of the sensor stem is immersed for accurate temperature measurement. This can be checked by inspecting the upper edge of the material coating of the end of the calibrated temperature sensor, removing the sensor from the cylinder if necessary.

7.2 Cleaning the apparatus

WARNING — The operating conditions may entail partial decomposition of the material under test or any material used to clean the instrument, or cause them to release dangerous volatile substances, as well as presenting the risk of burns. It is the responsibility of the user to establish appropriate safety and health practices and to ensure compliance with any regulatory requirements.

The apparatus, including the cylinder, piston and die, shall be cleaned thoroughly after each determination.

The cylinder may be cleaned with cloth patches. The piston shall be cleaned while hot with a cotton cloth. The die may be cleaned with a closely fitting brass reamer, high-speed drill bit of 2,08 mm diameter, or wooden peg. Pyrolytic cleaning of the die in a nitrogen atmosphere at about 550 °C may also be used. Take care that the cleaning procedure used does not affect the cylinder and die dimensions or surface finish. Abrasives or materials likely to damage the surface of the piston, cylinder or die shall not be used.

The die bore shall be checked with a go/no-go gauge after cleaning.

When cleaning the cylinder, piston and dies, take care that any effect the cleaning process and cleaning materials, e.g. solvents and brushes, may have on the next determination is negligible, e.g. ensure that they do not appreciably accelerate degradation of the polymer.

7.3 Vertical alignment of the instrument

Ensure that the bore of the equipment is properly aligned in the vertical direction.

8 Procedure A: mass-measurement method

8.1 Selection of temperature and load

Refer to the material specification standard for testing conditions. If no material specification standard exists or where MVR or MFR test conditions are not specified therein, use an appropriate set of conditions from [Table A.1](#) based on knowledge of the melting point of the material or processing conditions recommended by the manufacturer.

8.2 Cleaning

Clean the apparatus (see 7.2). Before beginning a series of tests, ensure that the cylinder and piston have been at the selected temperature for not less than 15 min.

8.3 Selection of sample mass and charging the cylinder

Charge the cylinder with 3 g to 8 g of the sample according to the anticipated MFR or MVR (see Table 4). During charging, compress the material with the packing rod (5.2.1.1) using hand pressure. Ensure that the charge is as free from air as possible. Complete the charging process in less than 1 min. The preheat time of 5 min begins immediately after charging of the cylinder has been completed.

NOTE 1 Variations in the packing pressure used to compress the material in the cylinder can cause poor repeatability of results. For the analysis of materials of similar MFR or MVR, the use of the same mass of sample in all tests reduces variability in the data.

NOTE 2 For materials susceptible to oxidative degradation the effect of trapped air on results can be particularly significant.

Immediately put the piston in the cylinder. The piston may be either unloaded or preloaded with the test weight or, for materials with high flow rates, a smaller weight. If the MFR or MVR of the material is high, i.e. more than 10 g/10 min or 10 cm³/10 min, the loss of sample during preheating is appreciable. In this case, use an unloaded piston or one carrying a smaller load during the preheating period. In the case of very high melt flow rates, a weight support should preferably be used and a die plug may be necessary.

During the preheating time, check that the temperature has returned to that selected, within the limits specified in Table 2.

To minimize the risk of burns from hot material coming out of the die rapidly, it is recommended that heat-resistant gloves be worn during the removal of the die plug.

Table 4 — Guidelines for experimental parameters

MFR (g/10 min) MVR (cm ³ /10 min) ^a	Sample mass in cylinder ^{b, c, e}	Extrudate cut-off time interval ^f
	g	s
> 0,1 but ≤ 0,15	3 to 5	240
> 0,15 but ≤ 0,4	3 to 5	120
> 0,4 but ≤ 1	4 to 6	40
> 1 but ≤ 2	4 to 6	20

^a It is recommended that a melt flow rate should not be measured if the value obtained in this test is less than 0,1 g/10 min (MFR) or 0,1 cm³/10 min (MVR). MFRs > 100 g/10 min should only be measured using a standard die if the timer resolution is 0,01 s and procedure B is used. Alternatively, the half size die may be used with procedure A (see 5.1.5).

^b When the density of the material is greater than 1,0 g/cm³, it may be necessary to increase the mass of the test sample. Use the low mass values for low-density materials.

^c Sample mass is a significant factor in determining the repeatability of this test and may need to be controlled to 0,1 g to reduce variability between runs.

^d To achieve sufficient accuracy for an MFR > 10 g/10 min, either higher precision of measurement of time, longer cut-off intervals or procedure B may be required.

^e When using the half size die a greater amount of material is required to compensate for the reduced volume of the die. The additional volume of material required is 0,3 cm³.

^f These times are consistent with the production of an extrudate length of 10 mm to 20 mm (see 8.4). In operating within this constraint, the errors can be significant, particularly for high MFR materials that have short extrudate cut-off times. A reduction in measurement errors could potentially be achieved by using larger extrudate cut-off times. The effect of instrumentation resolution on errors is instrument dependent and can be assessed by performing an uncertainty budget analysis.

Table 4 (continued)

MFR (g/10 min) MVR (cm ³ /10 min) ^a	Sample mass in cylinder ^{b, c, e} g	Extrudate cut-off time interval ^f s
> 2 but ≤ 5	4 to 8	10
> 5 ^d	4 to 8	5

^a It is recommended that a melt flow rate should not be measured if the value obtained in this test is less than 0,1 g/10 min (MFR) or 0,1 cm³/10 min (MVR). MFRs > 100 g/10 min should only be measured using a standard die if the timer resolution is 0,01 s and procedure B is used. Alternatively, the half size die may be used with procedure A (see 5.1.5).

^b When the density of the material is greater than 1,0 g/cm³, it may be necessary to increase the mass of the test sample. Use the low mass values for low-density materials.

^c Sample mass is a significant factor in determining the repeatability of this test and may need to be controlled to 0,1 g to reduce variability between runs.

^d To achieve sufficient accuracy for an MFR > 10 g/10 min, either higher precision of measurement of time, longer cut-off intervals or procedure B may be required.

^e When using the half size die a greater amount of material is required to compensate for the reduced volume of the die. The additional volume of material required is 0,3 cm³.

^f These times are consistent with the production of an extrudate length of 10 mm to 20 mm (see 8.4). In operating within this constraint, the errors can be significant, particularly for high MFR materials that have short extrudate cut-off times. A reduction in measurement errors could potentially be achieved by using larger extrudate cut-off times. The effect of instrumentation resolution on errors is instrument dependent and can be assessed by performing an uncertainty budget analysis.

8.4 Measurements

At the end of the preheat period, i.e. 5 min after completing the charging of the cylinder, in the event that the piston was unloaded or underloaded during the preheat period, apply the required load to the piston. In the event that a die plug was used and the piston was unloaded or underloaded during the preheat period, apply the required load to the piston and allow the material to stabilize for a few seconds before removing the die plug. If a weight support and die plug were both used, remove the weight support first.

NOTE It is possible that for some materials shorter preheating times will be required to prevent degradation. For high melting point, high T_g , low thermal conductivity materials, a longer preheating time can be needed to obtain repeatable results.

Allow the piston to descend under gravity until a bubble-free filament is extruded; this may be achieved before or after loading, depending on the actual viscosity of the material. It is strongly recommended that forced purging of the sample, done either manually or by using extra weights, before commencement of the test be avoided. If any forced purging is required (i.e. to complete the procedure within the specified time limit), it shall be finished at least 2 min before the start of the test. Any forced purging shall be carried out within a period of 1 min. If forced purging is used, it shall be reported in the test report. Cut off the extrudate with the cutting tool (5.2.2.1) and discard. Continue to allow the loaded piston to descend under gravity.

When the lower reference mark on the piston has reached the top edge of the cylinder, start the timer (5.2.2.2) and simultaneously cut off the extrudate with the cutting tool and discard.

Collect successive cut-offs in order to measure the extrusion rate for a given time-interval. Depending on the MFR, choose a time interval so that the length of a single cut-off is not less than 10 mm and preferably between 10 mm and 20 mm (see cut-off time-intervals in Table 4 and its footnote f as a guide).

For low values of MFR (and MVR) and/or materials which exhibit a relatively high degree of die swell, it may not be possible to take a cut-off with a length of 10 mm or more within the maximum permitted cut-off time-interval of 240 s. In such cases, procedure A may be used but only if the mass of each cut-off obtained in 240 s is greater than 0,04 g. If not, procedure B shall be used.

Stop cutting when the upper mark on the piston stem reaches the top edge of the cylinder. Discard all cut-offs containing visible air bubbles. After cooling, weigh individually, to the nearest 1 mg, the remaining cut-offs, preferably three or more, and calculate their average mass. If the difference between the maximum and the minimum values of the individual weighings exceeds 15 % of the average, discard the results and repeat the test on a fresh portion of the sample.

It is recommended that the cut-offs be weighed in order of extrusion. If a continuous change in mass is observed, this shall be reported as unusual behaviour (see [Clause 12](#)).

The time between the end of charging the cylinder and the end of the last measurement shall not exceed 25 min. For some materials, this time may need to be reduced to prevent degradation or cross-linking of the material during the test. In such cases, the use of ISO 1133-2 should be considered.

8.5 Expression of results

8.5.1 General

For testing with the standard die, use [8.5.2](#). For testing with the half size die, see also [8.5.3](#).

8.5.2 Expression of results: standard die

The melt mass-flow rate (MFR), expressed in grams per 10 min, is given by [Formula \(1\)](#):

$$\text{MFR}(T, m_{\text{nom}}) = \frac{600 \times m}{t} \quad (1)$$

where

T is the test temperature, in degrees Celsius;

m_{nom} is the mass, in kilograms, exerting the nominal load;

600 is the factor used to convert grams per second into grams per 10 min (600 s);

m is the average mass of the cut-offs, in grams;

t is the cut-off time-interval, in seconds.

The melt volume-flow rate (MVR) may be calculated from the MFR using [Formula \(2\)](#):

$$\text{MVR}(T, m_{\text{nom}}) = \frac{\text{MFR}(T, m_{\text{nom}})}{\rho} \quad (2)$$

where ρ is the density of the melt, in grams per cubic centimetre, and is given by the material specification standard or, if not specified therein, obtained at the test temperature ([9.6.2](#)).

NOTE The density of the melt is required at the test temperature and pressure. In practice, the pressure is low and values obtained at the test temperature and ambient pressure suffice.

For flow properties, MVR is the preferred measure as it is independent of the melt density ([Clause 9](#)).

Express the result to three significant figures but with a maximum of two decimal places and record the test temperature and load used, e.g. MFR = 10,6 g/10 min (190 °C/2,16 kg), MFR = 0,15 g/10 min (190 °C/2,16 kg).

8.5.3 Expression of results: half size die

When reporting results obtained using the half size die the subscript “h” shall be used (see [5.1.5](#)).

The MFR and/or MVR are calculated using the equations in [8.5.2](#).

Express the result to three significant figures, but with a maximum of two decimal places, and record the test temperature and load used, e.g. $MFR_h = 0,15 \text{ g}/10 \text{ min}$ (190 °C/2,16 kg), $MVR_h = 15,3 \text{ cm}^3/10 \text{ min}$ (190 °C/2,16 kg).

9 Procedure B: displacement-measurement method

9.1 Selection of temperature and load

See [8.1](#).

9.2 Cleaning

Clean the apparatus (see [7.2](#)). Before beginning a series of tests, ensure that the cylinder and piston have been at the selected temperature for not less than 15 min.

9.3 Minimum piston displacement distance

For improved accuracy and repeatability of measurements the minimum piston displacement distances listed in [Table 5](#) are suggested.

Table 5 — Guidelines for experimental parameters

MVR (cm ³ /10 min) MFR (g/10 min)	Minimum piston displacement mm
> 0,1 but ≤ 0,15	0,5
> 0,15 but ≤ 0,4	1
> 0,4 but ≤ 1	2
> 1 but ≤ 20	5
> 20	10

NOTE 1 These values permit at least three measurements to be made for each barrel charge. Operation of the instrument using values greater than these minimum piston displacements should also lead to reduced measurement errors due primarily to the instrument’s displacement resolution. For MVR values less than 0,4 cm³/10 min a maximum time of 240 s may result in a further reduction in errors but still permit at least three measurements. The effect of instrumentation resolution on errors is instrument dependent and can be assessed by performing an uncertainty budget analysis.

NOTE 2 For some materials, results can vary depending on the distance moved by the piston. For improved repeatability, it is critical to maintain the same distance moved for individual runs.

9.4 Selection of sample mass and charging the cylinder

See [8.3](#).

9.5 Measurements

At the end of the preheat period, i.e. 5 min after completing the charging of the cylinder, in the event that the piston was unloaded or underloaded during the preheat period, apply the required load to the piston. In the event that a die plug was used and the piston was unloaded or underloaded during the preheat period, apply the required load to the piston and allow the material to stabilize for a few

seconds before removing the die plug. If a weight support and die plug were both used, remove the weight support first.

NOTE It is possible that for some materials, a shorter preheating time will be required to prevent degradation. For high melting point, high T_g , low thermal conductivity materials, a longer preheating time can be needed to obtain repeatable results.

Allow the piston to descend under gravity until a bubble-free filament is extruded; this may be achieved before or after loading, depending on the actual viscosity of the material. It is strongly recommended that forced purging of the sample before commencement of the test be avoided. If any forced purging is required, i.e. to complete the procedure within the specified time limit, a specified compression load shall be used. Any forced purging shall be carried out within a period of 1 min and shall be finished at least 2 min before the start of the test. If forced purging is used, the compression load and duration shall be reported in the test report. Cut off the extrudate with the cutting tool (5.2.2.1) and discard. Continue to allow the loaded piston to descend under gravity.

When the lower reference mark on the piston has reached the top edge of the cylinder, start the timer (5.2.2.2) and simultaneously cut off the extrudate with the cutting tool and discard.

Do not start taking measurements before the lower reference mark on the piston has reached the top edge of the cylinder.

Measure one of:

- a) the distances moved by the piston over a predetermined time period;
- b) the times taken by the piston to move a specified distance.

For some materials, results can vary depending on the distance moved by the piston. For improved repeatability, it is critical to maintain the same distance moved for individual runs.

Stop the measurements when the upper mark on the piston stem reaches the top edge of the cylinder.

The time between the end of charging the cylinder and the last measurement shall not exceed 25 min. For some materials, this time may need to be reduced to prevent degradation or cross-linking of the material during the test. In such cases, the use of ISO 1133-2 should be considered.

9.6 Expression of results

9.6.1 General

For testing with the standard die, use 9.6.2. For testing with the half size die, use 9.6.3.

9.6.2 Expression of results: standard die

The melt volume-flow rate (MVR), expressed in cubic centimetres per 10 min, is given by [Formula \(3\)](#):

$$\text{MVR}(T, m_{\text{nom}}) = \frac{A \times 600 \times l}{t} \quad (3)$$

where

T is the test temperature, in degrees Celsius;

m_{nom} is the mass, in kilograms, exerting the nominal load;

A is the mean of the nominal cross-sectional areas of the cylinder and the piston head, in square centimetres and is equal to 0,711 cm² (see NOTE 1);

- 600 is the factor used to convert cubic centimetres per second into cubic centimetres per 10 min (600 s);
- l is the predetermined distance moved by the piston or the mean value of the individual distance measurements, in centimetres (see [9.3](#), [9.5](#));
- t is the predetermined time of measurement or the mean value of the individual time measurements, in seconds (see [9.3](#), [9.5](#)).

NOTE 1 Due to the tolerances permitted on the cylinder and piston diameters, the mean of the actual cross-sectional areas of the cylinder and the piston head varies by less than $\pm 0,5$ %. This effect is considered negligible and for simplicity of operation the nominal value of $0,711 \text{ cm}^2$ is used.

The melt mass-flow rate (MFR), expressed in grams per 10 min, is given by [Formula \(4\)](#):

$$\text{MFR}(T, m_{\text{nom}}) = \frac{A \times 600 \times l \times \rho}{t} \quad (4)$$

where the symbols given above apply and ρ is the density, in grams per cubic centimetre, of the melt at the test temperature given by [Formula \(5\)](#):

$$\rho = \frac{m}{A \times l} \quad (5)$$

in which m is the mass, in grams, determined by weighing, of extrudate expelled by a piston movement of l cm.

NOTE 2 It is possible that a value for density is specified in the material specification standard.

NOTE 3 The density of the melt is required at the test temperature and pressure. In practice, the pressure is low and values obtained at the test temperature and ambient pressure suffice.

Express the result to three significant figures but with a maximum of two decimal places, and record the test temperature and load used, e.g. MVR = $10,6 \text{ cm}^3/10 \text{ min}$ ($190 \text{ }^\circ\text{C}/2,16 \text{ kg}$), MVR = $0,15 \text{ cm}^3/10 \text{ min}$ ($190 \text{ }^\circ\text{C}/2,16 \text{ kg}$).

9.6.3 Expression of results: half size die

When reporting results obtained using the half size die, the subscript symbol “h” shall be used (see [5.1.5](#)).

The MFR and/or MVR are calculated using the equations in [9.6.2](#).

Express the result to three significant figures but with a maximum of two decimal places, and record the test temperature and load used, e.g. $\text{MVR}_h = 0,15 \text{ cm}^3/10 \text{ min}$ ($190 \text{ }^\circ\text{C}/2,16 \text{ kg}$) or $\text{MFR}_h = 15,0 \text{ g}/10 \text{ min}$ ($190 \text{ }^\circ\text{C}/2,16 \text{ kg}$).

10 Flow rate ratio

The ratio of two values of MFR (or MVR) obtained for a material tested at the same temperature but with different loads is called the flow rate ratio (FRR), e.g.

$$\text{FRR} = \frac{\text{MFR}(190 \text{ }^\circ\text{C} / 10,0 \text{ kg})}{\text{MFR}(190 \text{ }^\circ\text{C} / 2,16 \text{ kg})}$$

NOTE The FRR is commonly used as an indication of the way in which the rheological behaviour of a thermoplastic is influenced by the molecular mass distribution of the material.

For the conditions to be used for the determination of the FRR, refer to the appropriate material standards. If no material standard exists or if no FRR test conditions are specified in the material standard, the test conditions should be agreed between the interested parties.

Express results to two significant figures, or three if both the MFR or MVR values are expressed to three.

For the FRR obtained using the half size die, the symbol FRR_h shall be used.

11 Precision

Consideration shall be given to the factors that may influence the magnitude of the measured values and may lead to a decrease in repeatability. Such factors include:

- a) thermal degradation or cross-linking of the material, causing the melt flow rate to change during the preheating or test period (powdered materials requiring long preheating times are sensitive to this effect and, in certain cases, the inclusion of stabilizers is necessary to reduce the variability);
- b) the length, distribution and orientation of the filler in filled or reinforced materials may affect the melt flow rate.

The precision of the method is not known because interlaboratory data are not available. A single precision statement would not be suitable because of the number of materials and the wide range in the test parameters covered. However, earlier data indicated a coefficient of variation of about $\pm 10\%$ could be expected between laboratories and $\pm 5\%$ within a laboratory. More recent data on one high flow rate polypropylene grade are presented in [Annex D](#).

12 Test report

The test report shall include at least the following information:

- a) a reference to this document, i.e. ISO 1133-1:2022;
- b) all details necessary for the complete identification of the test sample, including the physical form of the material with which the cylinder was charged;
- c) the details of pre-treatment conditions, including drying and preforming conditions and, where applicable, the precompression load and time used for forced purging prior to measurement;
- d) the details of any stabilization (see [6.2](#));
- e) the temperature and load used in the test;
- f) the pre-heat time used (when a value other than 5 min was used);
- g) for procedure A, the masses of the cut-offs and the cut-off time-intervals,
or
for procedure B, the predetermined time of measurement or distance moved by the piston and the corresponding measured values of the distance moved by the piston or the time of measurement;
- h) the melt mass-flow rate (MFR), in grams per 10 min,
or
the melt volume-flow rate (MVR), in cubic centimetres per 10 min, expressed to three significant figures but with a maximum of two decimal places.

When more than one melt flow rate value has been obtained from a single cylinder charge, the mean value shall be reported as the melt flow rate. All individual values shall also be reported and identified as such;

- i) if appropriate, where an MFR or MVR value has been calculated using the melt density in accordance with [8.5.2](#) or [9.6.2](#) and is reported in the test report, it shall also be stated that the value has been calculated. Report the value of density used for the conversion;
- j) when reporting MFR and/or MVR values obtained using the half size die, the subscript “h” shall be used, and the fact that a half size die was used shall be stated;
- k) if appropriate, the flow rate ratio (FRR);
- l) a report of any unusual behaviour of the test sample, such as discoloration, sticking and extrudate distortion (sharkskin) or unexpected variation in melt flow rate;
- m) the date of the test.

Annex A (normative)

Test conditions for MFR and MVR determinations

The conditions used shall be as indicated in the appropriate material specification standard.

[Table A.1](#) indicates test temperatures and loads that have been found useful. Other test conditions not listed here may be used, if necessary, for a particular material.

Table A.1 — Test conditions for MFR and MVR determinations

Test temperature
<i>T</i>
°C
100
125
150
190
200
220
230
235
240
250
260
265
275
280
300

It is recommended that the temperatures and loads listed be used for new thermoplastic materials where material standards either do not exist or do not specify such testing conditions. Any combination of temperature and load may be used. However, the choice of temperature and load should be based on the rheological properties of the material.

NOTE For the code-letters that were presented in versions up to ISO 1133:2005 to describe specific combinations of temperature and load for testing and as used in material designations codes, the user is referred to ISO 1133:1997.

Table A.1 (continued)

Nominal load (combined)	
	m_{nom} kg
	0,325
	1,20
	2,16
	3,80
	5,00
	10,00
	21,60

It is recommended that the temperatures and loads listed be used for new thermoplastic materials where material standards either do not exist or do not specify such testing conditions. Any combination of temperature and load may be used. However, the choice of temperature and load should be based on the rheological properties of the material.

NOTE For the code-letters that were presented in versions up to ISO 1133:2005 to describe specific combinations of temperature and load for testing and as used in material designations codes, the user is referred to ISO 1133:1997.

Annex B (informative)

Conditions specified in International Standards for the determination of the melt flow rate of thermoplastic materials

Testing conditions for materials can be found in the relevant materials specification standards, e.g. those listed in [Table B.1](#).

Table B.1 — Conditions specified in International Standards for the determination of the melt flow rate of thermoplastic materials

Materials	International Standard (see Bibliography)
ABS	ISO 19062
ASA, ACS, AEDPS	ISO 19065
E/VAC	ISO 21301
MABS	ISO 19066
PB ^a	ISO 21302 ISO 15494 ISO 15876
PC	ISO 21305
PE ^a	ISO 17855 ISO 4427 ISO 4437 ISO 15494 ISO 22391
PMMA	ISO 24026
POM	ISO 29988
PP ^a	ISO 19069 ISO 15494 ISO 15874
PS	ISO 24022
PS-I	ISO 19063
SAN	ISO 19064
^a Melt density values for this material may be included in the material standard.	

Annex C (informative)

Device and procedure for preforming a compacted charge of material by compression

C.1 General

This annex provides information on a method found suitable for preforming a compacted charge of material. This preforming of samples is particularly useful when determining the MFR and MVR of materials such as powders, flakes, strips of film, or fragments. Preforming such samples into compacted charges reduces problems associated with air entrapment and voids that lead to poor repeatability of results and permit quick introduction of the samples into the MFR/MVR cylinder. Other methods of preforming a charge of material may be suitable.

C.2 Principle

Powders, flakes, strips of film, or fragments of moulded products are preformed by compression under vacuum into a compacted charge whose diameter is close to, but not more than, the internal diameter of the cylinder of the melt flow rate instrument. The temperature at which the material is compressed should be below the melting temperature, T_m , for semi-crystalline polymers and near the glass transition temperature, T_g , for amorphous polymers, in order to minimize air-entrapment without incurring excessive thermal degradation.

C.3 Apparatus

C.3.1 General. The apparatus should consist of a heatable cylinder that is closed at the bottom by an end plug. Pressure should be exerted on the material in this cylinder by a piston. [Figure C.1](#) shows an example of such equipment. The apparatus consists of the essential parts detailed in [C.3.2](#) to [C.3.6](#).

NOTE The use of apparatus of different design is allowed, e.g. a modified melt flow rate instrument.

C.3.2 Steel cylinder. The steel cylinder should be fixed in a vertical position and suitably insulated for operation up to 300 °C. The cylinder length should be between 115 mm and 180 mm and an internal diameter $(9,550 \pm 0,025)$ mm. An end plug closes the bottom of the cylinder by use of a plug-retaining nut.

C.3.3 Piston. A piston whose working length is at least as long as the cylinder. The piston should have a head of $(6,35 \pm 0,1)$ mm in length. The diameter of the piston head should be $(9,474 \pm 0,007)$ mm.

C.3.4 Heating and thermostatic devices. Heating and thermostatic devices should be used such that the selected temperature of the material in the cylinder can be maintained to within $\pm 3,0$ °C of the required temperature.

C.3.5 Load. The loading force exerted on the top of the piston should be $(2 \pm 0,5)$ kN and can be applied by any suitable means, e.g. mechanical, pneumatic. This is applied to preform the sample into a compacted charge and to extrude the charge from the cylinder after removal of the end plug.

C.3.6 Vacuum pump. A vacuum pump should be used to remove or reduce moisture and gases entrapped in the material prior to, during and after preforming to prevent further contamination.

C.4 Conditioning

Materials shall be conditioned as necessary prior to forming into a compacted charge in accordance with the appropriate materials specification standard. See also clauses on conditioning of the material as appropriate (6.2 and ISO 1133-2).

C.5 Compaction procedure

Set the cylinder temperature to 10 °C to 20 °C below the melting temperature, T_m , for a semi-crystalline sample and to 10 °C to 20 °C below the glass-transition temperature, T_g , for an amorphous sample. Other temperature ranges may be used if these values are found not to be appropriate but should be below T_m for semi-crystalline materials or below T_g for amorphous materials.

NOTE 1 The specified temperature ranges have been found to be appropriate for a range of materials. Powders and flakes are only partially softened and compressed under vacuum into a compacted charge.

Clean the cylinder and the piston with cloth patches.

Close the bottom of the cylinder using the end plug.

Charge the cylinder with the conditioned sample. The amount used should not be less than that required for MVR/MFR testing of the material: see Table 4 for guidelines on minimum amount required for testing. During charging, compress the material using a packing rod. In the case of materials with low bulk density, fill the cylinder with a smaller quantity, compress, and repeat until the cylinder is charged with the required amount.

Vacuum should be applied to the charge of material, provided it is not prohibited by the material specification standard.

NOTE 2 The use of vacuum can be used to improve compaction of the material and to minimize moisture uptake by the material.

Immediately after charging the cylinder apply a force of $(2,0 \pm 0,5)$ kN to the piston and hold for 2 min.

Remove the piston load. After removing the end plug, extrude the charge from the cylinder by lowering the piston.

C.6 Handling of compacted charge

The compacted charge shall be cooled down prior to MFR or MVR testing, unless otherwise specified in the appropriate material specification standard.

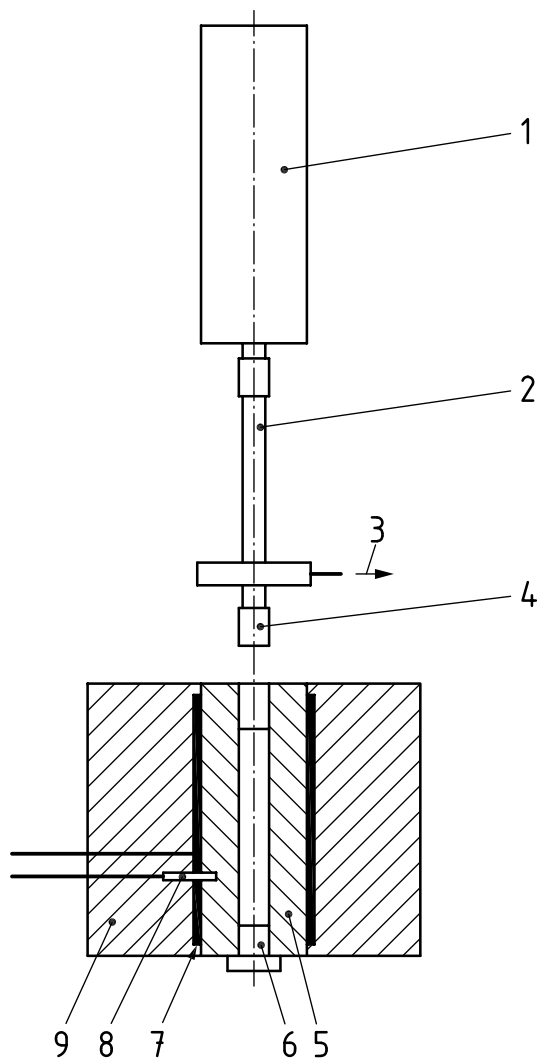

Key

- 1 air-cylinder
- 2 piston
- 3 vacuum device with seal to cylinder
- 4 piston head
- 5 cylinder
- 6 end plug
- 7 heater
- 8 temperature sensor
- 9 insulation

Figure C.1 — Example of apparatus for performing a compacted charge by compression

Annex D (informative)

Precision data for polypropylene obtained from an intercomparison of MFR and MVR testing

The results of an intercomparison of melt mass flow rate (MFR) and melt volume flow rate (MVR) measurements on a high melt flow rate polypropylene using testing conditions of 2,16 kg and 230 °C carried out in 2007 (Reference [20]) are presented in Table D.1. It is emphasized that the material tested was a high melt flow rate material and thus the precision obtained for it is unlikely to be representative of the method at all melt flow rates. The precision of the method is also very material dependent. The results of only one laboratory for MVR were discarded as being outliers.

Table D.1 — Intercomparison results on a high melt flow rate polypropylene

Method	Number of laboratories participating	Mean value of MFR or MVR	Within laboratory		Between laboratories	
			Standard deviation	Repeatability limit	Standard deviation	Reproducibility limit
			s_r %	$r(2,8 s_r)$ %	s_R %	$R(2,8 s_R)$ %
MFR	8	43,4 g/10 min	2,2	6,2	7,4	20,8
MVR	16	59,3 cm ³ /10 min	1,6	4,5	3,7	10,5

Note that these values give a ratio of MFR to MVR of 731,8 kg/m³, compared with the value of 738,6 kg/m³ specified in ISO 19069-2 for calculating the mass flow rate from the volume flow rate, a difference in values of 1 %.

Bibliography

- [1] ISO 24022 (all parts), *Plastics — Polystyrene (PS) moulding and extrusion materials*
- [2] ISO 17855 (all parts), *Plastics — Polyethylene (PE) moulding and extrusion materials*
- [3] ISO 19069 (all parts), *Plastics — Polypropylene (PP) moulding and extrusion materials*
- [4] ISO 19062 (all parts), *Plastics — Acrylonitrile-butadiene-styrene (ABS) moulding and extrusion materials*
- [5] ISO 19063 (all parts), *Plastics — Impact-resistant polystyrene (PS-I) moulding and extrusion materials*
- [6] ISO 4427 (all parts), *Plastics piping systems for water supply and for drainage and sewerage under pressure — Polyethylene (PE)*
- [7] ISO 4437 (all parts), *Plastics piping systems for the supply of gaseous fuels — Polyethylene (PE)*
- [8] ISO 21301 (all parts), *Plastics — Ethylene-vinyl acetate (EVAC) moulding and extrusion materials*
- [9] ISO 19064 (all parts), *Plastics — Styrene-acrylonitrile (SAN) moulding and extrusion materials*
- [10] ISO 19065 (all parts), *Plastics — Acrylonitrile-styrene-acrylate (ASA), acrylonitrile-(ethylene-propylene-diene)-styrene (AEPDS) and acrylonitrile-(chlorinated polyethylene)-styrene (ACS) moulding and extrusion materials*
- [11] ISO 21305 (all parts), *Plastics — Polycarbonate (PC) moulding and extrusion materials*
- [12] ISO 24026 (all parts), *Plastics — Poly(methyl methacrylate) (PMMA) moulding and extrusion materials*
- [13] ISO 21302 (all parts), *Plastics — Polybutene-1 (PB-1) moulding and extrusion materials*
- [14] ISO 29988 (all parts), *Plastics — Polyoxymethylene (POM) moulding and extrusion materials*
- [15] ISO 19066 (all parts), *Plastics — Methyl methacrylate-acrylonitrile-butadiene-styrene (MABS) moulding and extrusion materials*
- [16] ISO 15494, *Plastics piping systems for industrial applications — Polybutene (PB), polyethylene (PE), polyethylene of raised temperature resistance (PE-RT), crosslinked polyethylene (PE-X), polypropylene (PP) — Metric series for specifications for components and the system*
- [17] ISO 15874 (all parts), *Plastics piping systems for hot and cold water installations — Polypropylene (PP)*
- [18] ISO 15876 (all parts), *Plastics piping systems for hot and cold water installations — Polybutene (PB)*
- [19] ISO 22391 (all parts), *Plastics piping systems for hot and cold water installations — Polyethylene of raised temperature resistance (PE-RT)*
- [20] RIDES, M., ALLEN, C., OMLOO, H., NAKAYAMA, K., CANCELLI, G. Interlaboratory comparison of melt flow rate testing of moisture sensitive plastics. *Polym. Test.* 2009, **28**, pp. 572-591
- [21] ISO 1133-2, *Plastics — Determination of the melt mass-flow rate (MFR) and melt volume-flow rate (MVR) of thermoplastics — Part 2: Method for materials sensitive to time-temperature history and/or moisture*
- [22] ISO 21920-2, *Geometrical product specifications (GPS) — Surface texture: Profile — Part 2: Terms, definitions and surface texture parameters*

- [23] ISO 6507-1, *Metallic materials — Vickers hardness test — Part 1: Test method*
- [24] ISO 1133:1997, *Plastics — Determination of the melt mass-flow rate (MFR) and the melt volume-flow rate (MVR) of thermoplastics¹⁾*

1) Superseded.

