**Plastics — Determination of Charpy
impact properties —**

**Part 1:
Non-instrumented impact test**

*Plastiques — Détermination des caractéristiques au choc Charpy —
Partie 1: Essai de choc non instrumenté*





COPYRIGHT PROTECTED DOCUMENT

© ISO 2023

All rights reserved. Unless otherwise specified, or required in the context of its implementation, no part of this publication may be reproduced or utilized otherwise in any form or by any means, electronic or mechanical, including photocopying, or posting on the internet or an intranet, without prior written permission. Permission can be requested from either ISO at the address below or ISO's member body in the country of the requester.

ISO copyright office
CP 401 • Ch. de Blandonnet 8
CH-1214 Vernier, Geneva
Phone: +41 22 749 01 11
Email: copyright@iso.org
Website: www.iso.org

Published in Switzerland

Contents

	Page
Foreword	iv
Introduction	v
1 Scope	1
2 Normative references	1
3 Terms and definitions	1
4 Principle	2
5 Apparatus	3
5.1 Test machine.....	3
5.2 Micrometers and gauges.....	3
6 Test specimens	4
6.1 Preparation.....	4
6.1.1 Moulding and extrusion compounds.....	4
6.1.2 Sheets.....	4
6.1.3 Long-fibre-reinforced materials.....	4
6.1.4 Checking.....	6
6.1.5 Notching.....	7
6.2 Anisotropy.....	7
6.3 Shape and dimensions.....	7
6.3.1 Materials not exhibiting interlaminar shear fracture.....	7
6.3.2 Materials exhibiting interlaminar shear fracture (e.g. long-fibre-reinforced materials).....	9
6.4 Number of test specimens.....	9
6.5 Span between specimen supports, L	10
6.6 Conditioning.....	10
7 Procedure	11
8 Calculation and expression of results	12
8.1 Unnotched specimens.....	12
8.2 Notched specimens.....	12
8.3 Statistical parameters.....	12
8.4 Significant figures.....	12
9 Precision	12
10 Test report	13
Annex A (informative) Additional methods for investigating the influence of surface effects	15
Annex B (informative) Precision data	17
Annex C (informative) Determining the notch tip radius using a CCD microscope	19
Bibliography	22

Foreword

ISO (the International Organization for Standardization) is a worldwide federation of national standards bodies (ISO member bodies). The work of preparing International Standards is normally carried out through ISO technical committees. Each member body interested in a subject for which a technical committee has been established has the right to be represented on that committee. International organizations, governmental and non-governmental, in liaison with ISO, also take part in the work. ISO collaborates closely with the International Electrotechnical Commission (IEC) on all matters of electrotechnical standardization.

The procedures used to develop this document and those intended for its further maintenance are described in the ISO/IEC Directives, Part 1. In particular, the different approval criteria needed for the different types of ISO document should be noted. This document was drafted in accordance with the editorial rules of the ISO/IEC Directives, Part 2 (see www.iso.org/directives).

ISO draws attention to the possibility that the implementation of this document may involve the use of (a) patent(s). ISO takes no position concerning the evidence, validity or applicability of any claimed patent rights in respect thereof. As of the date of publication of this document, ISO had not received notice of (a) patent(s) which may be required to implement this document. However, implementers are cautioned that this may not represent the latest information, which may be obtained from the patent database available at www.iso.org/patents. ISO shall not be held responsible for identifying any or all such patent rights.

Any trade name used in this document is information given for the convenience of users and does not constitute an endorsement.

For an explanation of the voluntary nature of standards, the meaning of ISO specific terms and expressions related to conformity assessment, as well as information about ISO's adherence to the World Trade Organization (WTO) principles in the Technical Barriers to Trade (TBT), see www.iso.org/iso/foreword.html.

This document was prepared by Technical Committee ISO/TC 61, *Plastics*, Subcommittee SC 2, *Mechanical behavior*, in collaboration with the European Committee for Standardization (CEN) Technical Committee CEN/TC 249, *Plastics*, in accordance with the Agreement on technical cooperation between ISO and CEN (Vienna Agreement).

This third edition cancels and replaces the second edition (ISO 179-1:2010), which has been technically revised.

The main changes are as follows:

- results of a round robin for unnotched specimens (see [Annex B](#)) have been added;
- reference to standard ISO 16012 (see the Bibliography and [subclause 5.2](#)) has been added;
- improvements of the micrometers and gauges subclause (see [5.2](#)) have been addressed;
- symbols used in [Formulae \(1\)](#) and [\(2\)](#) have been reviewed and updated.

A list of all parts in the ISO 179 series can be found on the ISO website.

Any feedback or questions on this document should be directed to the user's national standards body. A complete listing of these bodies can be found at www.iso.org/members.html.

Introduction

The Charpy impact properties determination method described in the ISO 179 series has a greater range of applicability than that given in ISO 180 and is more suitable for the testing of materials showing interlaminar shear fracture or of materials exhibiting surface effects due to environmental factors.

The method is suitable for use with the following range of materials:

- rigid thermoplastic moulding and extrusion materials (including filled and reinforced compounds in addition to unfilled types) and rigid thermoplastics sheets;
- rigid thermosetting moulding materials (including filled and reinforced compounds) and rigid thermosetting sheets (including laminates);
- fibre-reinforced thermosetting and thermoplastic composites incorporating unidirectional or multi-directional reinforcements (such as mats, woven fabrics, woven rovings, chopped strands, combination and hybrid reinforcements, rovings and milled fibres) or incorporating sheets made from pre-impregnated materials (prepregs), including filled and reinforced compounds;
- thermotropic liquid-crystal polymers.

Notched samples are not normally suitable for use with rigid cellular materials, long-fibre-reinforced composites or thermotropic liquid-crystal polymers. In these cases, unnotched samples may be used.

The method is suited to the use of specimens moulded to the chosen dimensions, machined from the central portion of a standard multipurpose test specimen (see ISO 20753) or machined from finished or semifinished products such as mouldings, laminates and extruded or cast sheet.

Plastics — Determination of Charpy impact properties —

Part 1: Non-instrumented impact test

1 Scope

This document specifies a method for determining the Charpy impact strength of plastics under defined conditions. A number of different types of specimen and test configurations are defined. Different test parameters are specified according to the type of material, the type of test specimen and the type of notch.

The method can be used to investigate the behaviour of specified types of specimen under the impact conditions defined and for estimating the brittleness or toughness of specimens within the limitations inherent in the test conditions. It can also be used for the determination of comparative data from similar types of material.

2 Normative references

The following documents are referred to in the text in such a way that some or all of their content constitutes requirements of this document. For dated references, only the edition cited applies. For undated references, the latest edition of the referenced document (including any amendments) applies.

ISO 291, *Plastics — Standard atmospheres for conditioning and testing*

ISO 293, *Plastics — Compression moulding of test specimens of thermoplastic materials*

ISO 294-1, *Plastics — Injection moulding of test specimens of thermoplastic materials — Part 1: General principles, and moulding of multipurpose and bar test specimens*

ISO 294-3, *Plastics — Injection moulding of test specimens of thermoplastic materials — Part 3: Small plates*

ISO 295, *Plastics — Compression moulding of test specimens of thermosetting materials*

ISO 1268-11, *Fibre-reinforced plastics — Methods of producing test plates — Part 11: Injection moulding of BMC and other long-fibre moulding compounds — Small plates*

ISO 2818, *Plastics — Preparation of test specimens by machining*

ISO 10724-1, *Plastics — Injection moulding of test specimens of thermosetting powder moulding compounds (PMCs) — Part 1: General principles and moulding of multipurpose test specimens*

ISO 13802, *Plastics — Verification of pendulum impact-testing machines — Charpy, Izod and tensile impact-testing*

3 Terms and definitions

For the purposes of this document, the following terms and definitions apply.

ISO and IEC maintain terminology databases for use in standardization at the following addresses:

- ISO Online browsing platform: available at <https://www.iso.org/obp>
- IEC Electropedia: available at <https://www.electropedia.org/>

3.1 Charpy impact strength of unnotched specimens

a_{cU}
impact energy absorbed in breaking an unnotched specimen, referred to the original cross-sectional area of the specimen

Note 1 to entry: It is expressed in kilojoules per square metre (kJ/m²).

3.2 Charpy impact strength of notched specimens

a_{cN}
impact energy absorbed in breaking a notched specimen, referred to the original cross-sectional area of the specimen at the notch, where N = A, B or C, depending on the notch type

Note 1 to entry: See [6.3.1.1.2](#).

Note 2 to entry: It is expressed in kilojoules per square metre (kJ/m²).

3.3 edgewise impact

e
direction of blow parallel to the dimension b , with impact on the narrow longitudinal surface $h \times l$ of the specimen

Note 1 to entry: See [Figure 1 a\)](#) and [Figures 2 and 4](#).

3.4 flatwise impact

f
direction of blow parallel to the dimension h , with impact on the broad longitudinal surface $b \times l$ of the specimen

Note 1 to entry: See [Figure 1 b\)](#) and [Figures 3 and 4](#).

3.5 normal direction of blow

n
<laminar-reinforced plastics> impact with the direction of blow normal to the plane of reinforcement

Note 1 to entry: See [Figure 4](#).

3.6 parallel direction of blow

p
<laminar-reinforced plastics> impact with the direction of blow parallel to the plane of reinforcement

Note 1 to entry: See [Figure 4](#).

4 Principle

The test specimen, supported near its ends as a horizontal beam, is impacted by a single blow of a striker, with the line of impact midway between the supports, and bent at a high, nominally constant, velocity.

In the case of edgewise impact with notched specimens, the line of impact is directly opposite the single notch [see [Figure 1 a\)](#) and [Figure 2](#)].

The method specifies preferred dimensions for the test specimen. Tests which are carried out on specimens of different dimensions or with different notches, or specimens which are prepared under different conditions, can produce results which are not comparable. Other factors, such as the energy capacity of the apparatus, the impact velocity and the conditioning of the specimens can also influence

the results. Consequently, when comparative data are required, these factors shall be carefully controlled and recorded.

The method is not intended to be used as a source of data for design calculations. Information on the typical behaviour of a material can be obtained, however, by testing at different temperatures, by varying the notch radius and/or the specimen thickness and by testing specimens prepared under different conditions.

5 Apparatus

5.1 Test machine

The principles, characteristics and verification of suitable test machines are detailed in ISO 13802.

ISO 13802 describes partial verification and full verification. In the case of full verification, some items are difficult to verify when the apparatus is assembled. Such verifications are assumed to be incumbent on the manufacturer.

5.2 Micrometers and gauges

Micrometers and gauges shall allow to determine the relevant dimensions of the test specimens with an uncertainty not larger than 0,02 mm. For the determination of the dimension b_N of notched test specimens measuring tips appropriate for the contour of the notch shall be used. For general information on the determination of test specimen dimensions, see ISO 16012.

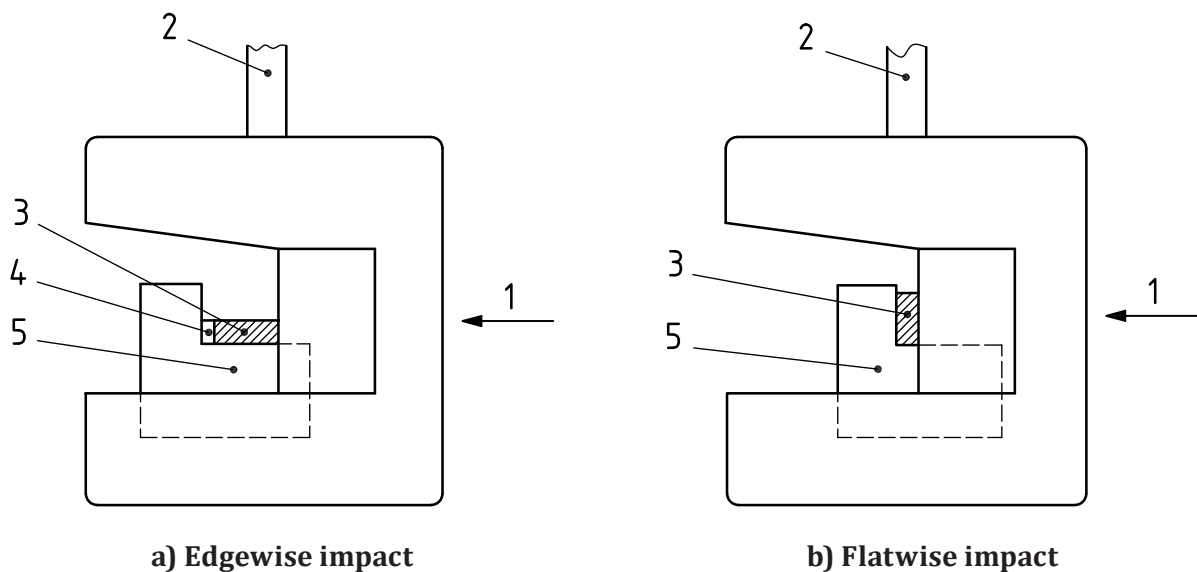

Key

- 1 direction of blow
- 2 rod of pendulum
- 3 test specimen
- 4 notch
- 5 support

Figure 1 — Striking edge and support blocks for type 1 test specimen at moment of impact

6 Test specimens

6.1 Preparation

6.1.1 Moulding and extrusion compounds

Specimens shall be prepared in accordance with the relevant material specification. The specimens shall be either directly compression moulded in accordance with ISO 293 or ISO 295 or injection moulded from the material in accordance with ISO 294-1, ISO 294-3 or ISO 10724-1, as appropriate, or machined in accordance with ISO 2818 from sheet that has been compression or injection moulded from the compound. Type 1 specimens may be cut from multipurpose test specimens complying with ISO 20753:—, type A1.

6.1.2 Sheets

Specimens shall be machined from sheets in accordance with ISO 2818.

6.1.3 Long-fibre-reinforced materials

A panel shall be prepared in accordance with ISO 1268-11 or another specified or agreed upon preparation procedure. Specimens shall be machined in accordance with ISO 2818.

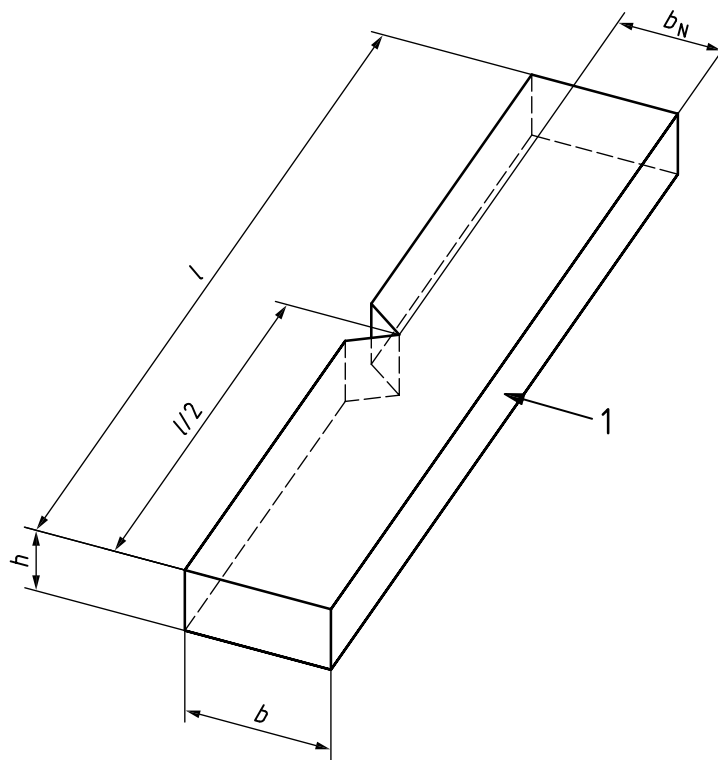

Key

1 direction of blow

Figure 2 — Charpy edgewise impact (e) with single-notched specimen

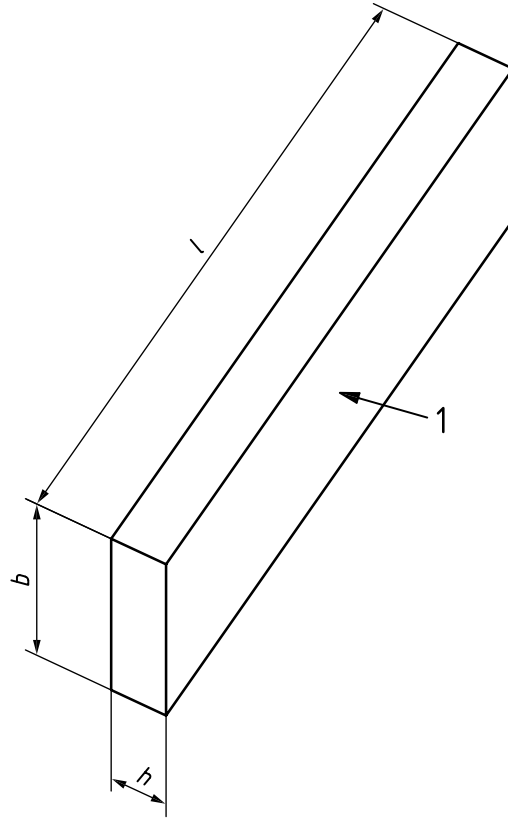
**Key**

1 direction of blow

Figure 3 — Charpy flatwise impact (f)

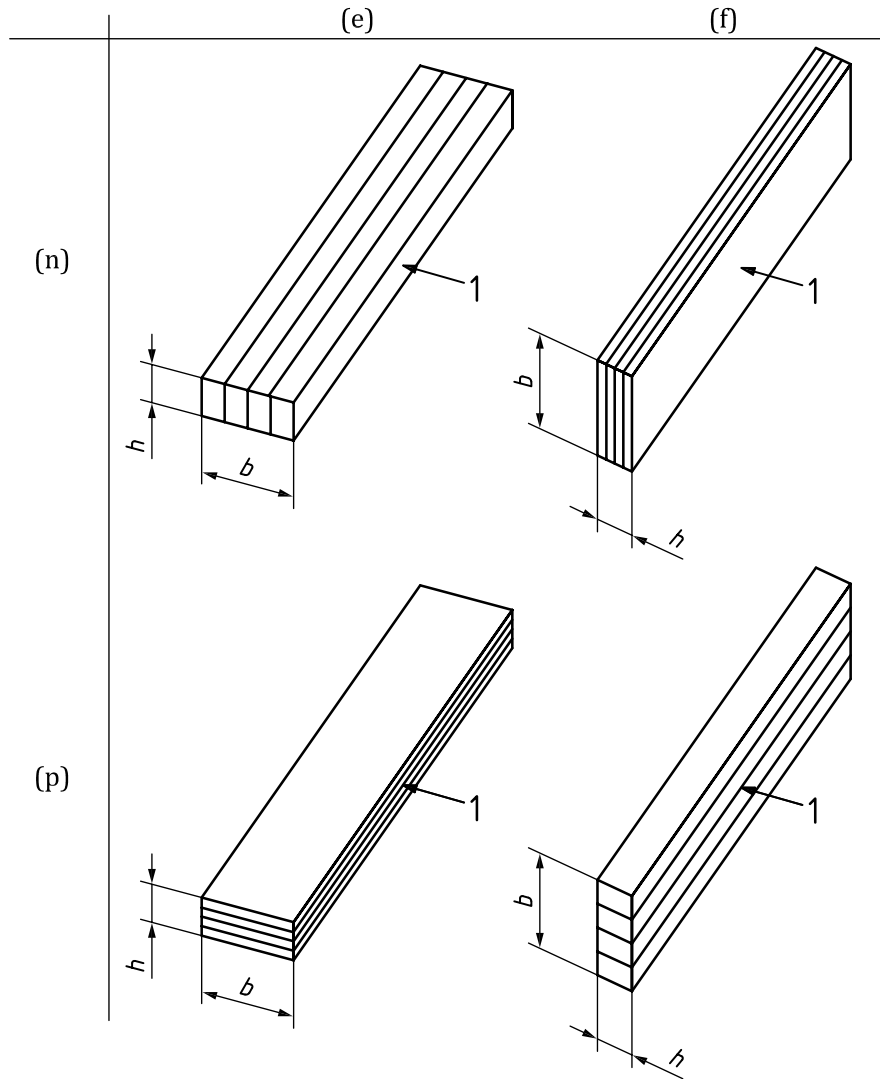

- Key**
- 1 direction of blow
 - e edgewise
 - f flatwise
 - n normal
 - p parallel

NOTE 1 Edgewise (e) and flatwise (f) indicate the direction of the blow with respect to the specimen thickness, h , and specimen width, b . Normal (n) and parallel (p) indicate the direction of the blow with respect to the laminate plane.

NOTE 2 The Charpy “fn” and “ep” tests are used for laminates, while both the Charpy “en” and “ep” tests are used for other materials. The Charpy “fn” and “fp” tests are used for testing materials exhibiting surface effects.

Figure 4 — Scheme of designations describing the direction of blow

6.1.4 Checking

The specimens shall be free of twist and shall have mutually perpendicular parallel surfaces. The surfaces and edges shall be free from scratches, pits, sink marks and flash.

The specimens shall be checked for conformity with these requirements by visual observation against straightedges, set squares and flat plates, and by measuring with micrometer callipers.

Specimens showing measurable or observable departure from one or more of these requirements shall be rejected or machined to proper size and shape before testing.

6.1.5 Notching

6.1.5.1 Machined notches shall be prepared in accordance with ISO 2818. The profile of the cutting tooth shall be such as to produce in the specimen a notch of the contour and depth as defined in [Table 2](#) and shown in [Figure 5](#), at right angles to its principal axes (see Note).

NOTE The radius of the notch tip can be measured by the method given in [Annex C](#).

6.1.5.2 Specimens with moulded-in notches may be used if specified for the material being tested (see Note).

NOTE Specimens with moulded-in notches do not give results comparable to those obtained from specimens with machined notches.

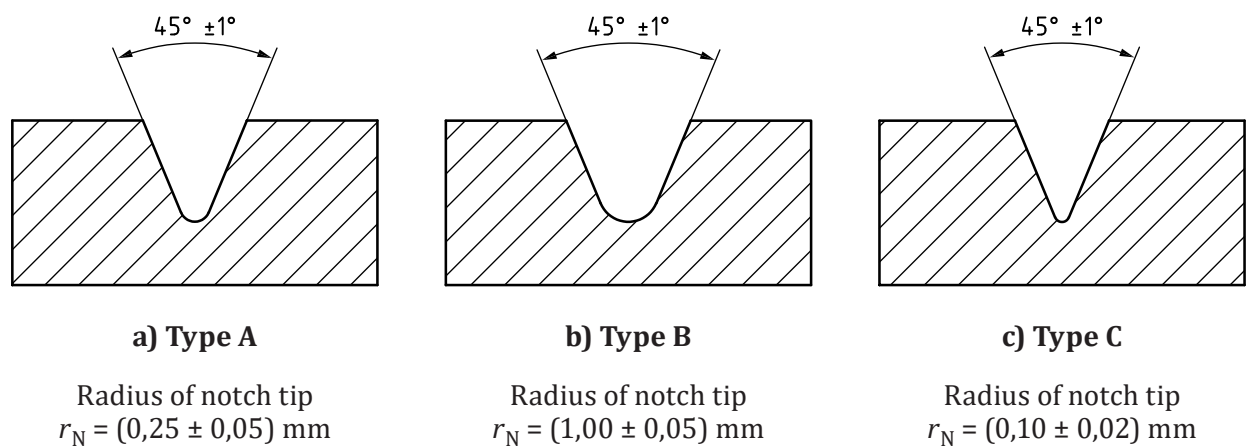

Figure 5 — Notch types

6.2 Anisotropy

Certain types of sheet or panel material or specimen taken from injection-moulded plates can show different impact properties, depending on the direction in the plane of the sheet or panel. In such cases, it is customary to cut groups of test specimens with their major axes respectively parallel and perpendicular to the direction of some feature of the sheet or panel which is either visible or inferred from knowledge of the method of manufacture.

6.3 Shape and dimensions

6.3.1 Materials not exhibiting interlaminar shear fracture

6.3.1.1 Moulding and extrusion compounds

6.3.1.1.1 Type 1 test specimens, unnotched or with one of three different types of notch, shall be used as specified in [Tables 1](#) and [2](#) and shown in [Figures 2](#) and [5](#). The notch shall be located at the centre

of the specimen. Type 1 specimens (see [Table 1](#)) may be taken from the central part of the type A1 multipurpose test specimen specified in ISO 20753.

Table 1 — Specimen types, specimen dimensions and spans between specimen supports^e

Dimensions in millimetres

Specimen type	Length ^a <i>l</i>	Width ^a <i>b</i>	Thickness ^a <i>h</i>	Span <i>L</i>
1	80 ± 2	10,0 ± 0,2	4,0 ± 0,2	62 ^{+0,5} _{-0,0}
2 ^b	25 <i>h</i>	10 or 15 ^c	3 ^d	20 <i>h</i>
3 ^b	11 <i>h</i> or 13 <i>h</i>	10,0 ± 0,2	4,0 ± 0,2	6 <i>h</i> or 8 <i>h</i>

^a The specimen dimensions (thickness, *h*, width, *b*, and length, *l*) are defined by $h < b < l$.

^b Specimen types 2 and 3 shall be used only for materials described in [6.3.2](#).

^c 10 mm for materials reinforced with a fine structure, 15 mm for those with a large stitch structure (see [6.3.2.2](#)).

^d Preferred thickness. If the specimen is cut from a sheet or a piece, *h* shall be equal to the thickness of the sheet or piece, up to 10,2 mm (see [6.3.1.2](#)).

^e See [Figures 2](#) and [6](#).

Table 2 — Method designations, specimen types, notch types and notch dimensions — Materials not exhibiting interlaminar shear fracture

Dimensions in millimetres

Method designation ^a	Specimen type	Blow direction	Notch type	Notch tip radius, <i>r_N</i> (see Figure 5)	Remaining width, <i>b_N</i> , at notch tip (see Figure 2)
ISO 179-1/1eA ^b	1	Edgewise	A	0,25 ± 0,05	8,0 ± 0,2
ISO 179-1/1eB			B	1,00 ± 0,05	8,0 ± 0,2
ISO 179-1/1eC			C	0,10 ± 0,02	8,0 ± 0,2
ISO 179-1/1eU ^b			Unnotched		
ISO 179-1/1fU ^c		Flatwise	Unnotched		

^a If specimens are taken from sheet or products, the thickness of the sheet or product shall be added to the designation. Unreinforced specimens shall not be tested with their machined surface under tension.

^b Preferred method.

^c Especially for the study of surface effects (see [6.3.1.1.3](#)).

6.3.1.1.2 The preferred type of notch is type A (see [Table 2](#) and [Figure 5](#)). For most materials, unnotched specimens or specimens with a single type A notch tested by edgewise impact (see [3.3](#)) are suitable. If specimens with a type A notch do not break during the test, specimens with a type C notch shall be used. If information on the notch sensitivity of the material is desired, specimens with notch types A, B and C shall be tested.

6.3.1.1.3 Unnotched or double-notched specimens tested by flatwise impact (see [3.4](#)) can be used to study surface effects (see [Annex A](#)).

6.3.1.2 Sheet materials

The recommended value of the thickness, *h*, is 4 mm. If the specimen is cut from a sheet or a piece taken from a structure, the thickness of the specimen, up to 10,2 mm, shall be the same as the thickness of the sheet or the structure.

Specimens taken from pieces thicker than 10,2 mm shall be machined to (10 ± 0,2) mm from one surface, provided that the sheet is homogeneous in its thickness and contains only one type of reinforcement

uniformly distributed. If unnotched or double-notched specimens are tested by flatwise impact, the original surface shall be tested under tension.

6.3.2 Materials exhibiting interlaminar shear fracture (e.g. long-fibre-reinforced materials)

6.3.2.1 Unnotched specimens of type 2 or 3 are used. Apart from the thickness, the specimen dimensions are not specified. The most important parameter is the ratio of the span between the specimen supports to the specimen dimension in the direction of the blow (see [Table 1](#)).

Usually specimens are tested in the normal direction (see [Figure 4](#)).

6.3.2.2 “Flatwise normal” testing (see [Figure 4](#)): the width of specimen shall be 10 mm for materials reinforced with a fine structure (thin fabrics and parallel yarns) and 15 mm for materials reinforced with a large stitch structure (roving fabrics) or an irregularly manufactured structure.

6.3.2.3 “Edgewise parallel” testing (see [Figure 4](#)): when testing specimens in the parallel direction, the specimen dimension perpendicular to the blow direction shall be the thickness of the sheet from which the specimen was cut.

6.3.2.4 The length, *l*, of the specimen shall be chosen to give a span-to-thickness ratio, *L/h*, of 20 for type 2 specimens and 6 for type 3 specimens although, if the apparatus does not allow a ratio *L/h* = 6, a ratio *L/h* = 8 may be used, especially for thin sheets, as indicated in [Table 1](#).

6.3.2.5 With type 2 specimens, tensile-type failure occurs; with type 3 specimens, interlaminar shear failure of the sheet usually occurs. The different types of failure which can occur are summarized in [Table 3](#).



NOTE In some cases (thin-fabric reinforcement), shear failure does not occur. In the case of type 3 specimens, the fracture starts as a single or multiple shear failure and continues as tensile failure.

6.4 Number of test specimens

6.4.1 Unless otherwise specified in the standard for the material being tested, a set consisting of 10 specimens shall be tested. When the coefficient of variation (see ISO 2602) has a value of less than 5 %, a minimum number of five test specimens is sufficient.



6.4.2 If laminates are tested in the normal and parallel directions, 10 specimens shall be used for each direction.

Table 3 — Method designation and specimen types — Materials exhibiting interlaminar shear fracture

Method designation	Specimen type	<i>L/h</i>	Type of failure	Schematic	
ISO 179-1/2 n or p ^a	2	20	Tension	t	
			Compression	c	
			Buckling	b	

^a “n” is the normal direction and “p” is the parallel direction with respect to the sheet plane (see [Figure 4](#)).

Table 3 (continued)

Method designation	Specimen type	L/h	Type of failure	Schematic	
ISO 179-1/3 n or p ^a	3	6 or 8	Shear	s	
			Multiple shear	ms	
			Shear followed by tensile fracture	st	

^a “n” is the normal direction and “p” is the parallel direction with respect to the sheet plane (see [Figure 4](#)).

6.5 Span between specimen supports, L

The span between the specimen supports, L , is defined as the distance between the lines of contact of the specimen with the supports. [Figure 6](#) shows the span, L , and a suitable way in which it can be determined by measuring the radius of the supports and the distance between them.

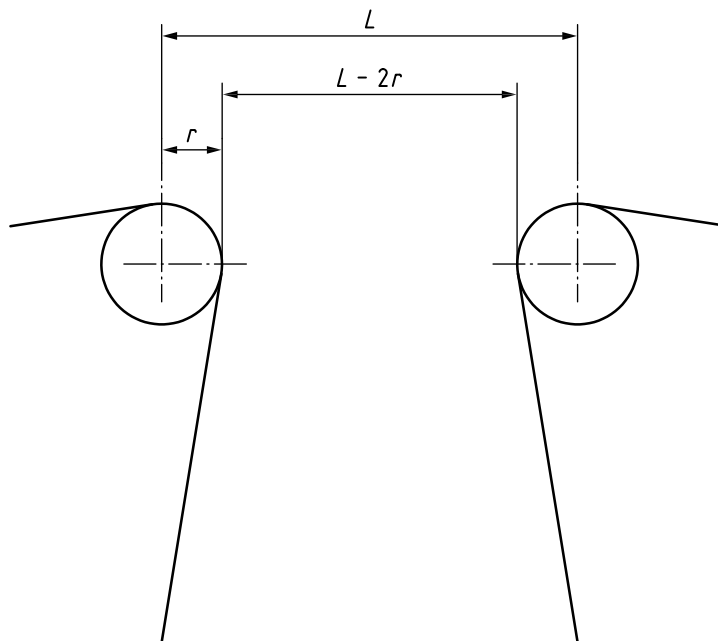

Figure 6 — Span, L , and suitable measurement position

6.6 Conditioning

Unless otherwise specified in the standard for the material under test, the specimens shall be conditioned for at least 16 h at $(23 \pm 2)^\circ\text{C}$ and $(50 \pm 10)\%$ relative humidity in accordance with ISO 291 Class 2 definition, unless other conditions are agreed upon by the interested parties. In the case of notched specimens, the conditioning time is after notching.

For materials with impact properties that are non-sensitive to moisture the relative humidity does not have to be controlled.

7 Procedure

7.1 Conduct the test in the same atmosphere as that used for conditioning, unless otherwise agreed upon by the interested parties, e.g. for testing at high or low temperatures.

7.2 Measure the thickness, h , and width, b , of each test specimen, in the centre, to the nearest 0,02 mm. In the case of notched specimens, carefully measure the remaining width, b_N , to the nearest 0,02 mm.

In the case of injection-moulded specimens, it is not necessary to measure the dimensions of each specimen. It is sufficient to measure one specimen from a set to make sure that the dimensions correspond to those in [Table 1](#). With multiple-cavity moulds, ensure that the dimensions of the specimens are the same for each cavity.

Check the span between the specimen supports and adjust it, if necessary, in accordance with [Table 1](#) and [6.5](#).

7.3 Check that the impact machine is able to perform the test with the specified velocity of impact and that it is in the correct range of absorbed energy, W , which shall be between 10 % and 80 % of the available energy at impact, E . If more than one of the pendulums conform to these requirements, the pendulum having the highest energy shall be used.

7.4 Determine the frictional losses and correct the absorbed energy in accordance with ISO 13802.

7.5 Lift the pendulum to the prescribed height and support it. Place the specimen on the supports in the machine in such a manner that the striking edge will hit the centre of the specimen. Carefully align notched specimens so that the centre of the notch is located directly in the plane of impact (see [Figure 1](#), left).

7.6 Release the pendulum. Record the impact energy absorbed by the specimen and apply any necessary corrections for frictional losses, etc. (see [7.4](#)).

7.7 For moulding and extrusion compounds, four types of failure, designated by the following code-letters, can occur:

- C (Complete break): a break in which the specimen separates into two or more pieces;
- H (Hinge break): an incomplete break such that both parts of the specimen are held together only by a thin peripheral layer in the form of a hinge having low residual stiffness;
- P (Partial break): an incomplete break that does not meet the definition for hinge break;
- N (Non-break): there is no break, and the specimen is only distorted, possibly combined with stress whitening.

Record the type of failure for the impacted specimen.

7.8 Repeat steps from [7.5](#) to [7.7](#) for all specimens to be tested.

8 Calculation and expression of results

8.1 Unnotched specimens

Calculate the Charpy impact strength of unnotched specimens, a_{cU} , expressed in kilojoules per square metre, using [Formula \(1\)](#):

$$a_{cU} = \frac{W_c}{h \times b} \times 10^3 \quad (1)$$

where

- W_c is the corrected energy, in joules, absorbed by breaking the test specimen;
- h is the thickness, in millimetres, of the test specimen;
- b is the width, in millimetres, of the test specimen.

8.2 Notched specimens

Calculate the Charpy impact strength of notched specimens, a_{cN} , expressed in kilojoules per square metre, with notches A, B or C, using [Formula \(2\)](#):

$$a_{cN} = \frac{W_c}{h \times b_N} \times 10^3 \quad (2)$$

where

- W_c is the corrected energy, in joules, absorbed by breaking the test specimen;
- h is the thickness, in millimetres, of the test specimen;
- b_N is the remaining width, in millimetres, of the test specimen.

8.3 Statistical parameters

Calculate as the test result the arithmetic mean of the individual test results and, if required, the standard deviation of the mean value, using the procedure given in ISO 2602. For each type of failure within one sample, the relevant numbers of specimens shall be given and mean values shall be calculated.

8.4 Significant figures

Report all calculated mean values to three significant figures.

9 Precision

See [Annex B](#).

10 Test report

The test report shall include the following information:

- a) a reference to this document, i.e. ISO 179-1:2023;
- b) the method used, designated in accordance with [Table 2](#), e.g.:

Charpy impact test ISO 179-1/ 1 e A

Specimen type (see Table 1) _____|

Direction of blow (see Figure 4) _____|

Type of notch (see Figure 5) _____|

or in accordance with [Table 3](#), e.g.:

Charpy impact test ISO 179-1/ 2 n

Specimen type (see Table 1) _____|

Direction of blow (see Figure 4) _____|

- c) all information necessary for identification of the material tested, including type, source, the manufacturer's code, grade and history, where these are known;
- d) a description of the nature and form of the material, i.e. whether a product, semifinished product, test plate or specimen, and including principal dimensions, shape, method of manufacture, etc., where these are known;
- e) the velocity of impact;
- f) the nominal pendulum energy;
- g) the method of test specimen preparation;
- h) if the material is in the form of a product or a semifinished product, the orientation of the test specimen in relation to the product or semifinished product from which it was cut;
- i) the number of specimens tested;
- j) the standard atmosphere used for conditioning and testing, plus any special conditioning treatment if required by the standard for the material or product;
- k) the type(s) of failure observed;
- l) the individual test results, presented as follows (see also [Table 4](#)):
- 1) group the results according to the three basic types of failure:
 - C complete break, including hinge break H
 - P partial break
 - N non-break,
 - 2) select the most frequent type and record the mean value, x , of the impact strength as the test result for this type of failure, followed by the letter C or P for the type of failure,
 - 3) if the most frequent failure type is N, record the letter N only,

- 4) add (between brackets) the letter C, P or N for the second most frequent failure type, but only if its frequency is higher than 1/3 (if not relevant, insert an asterisk);
- m) the standard deviations of the mean values, if required;
- n) the date(s) of testing.

Table 4 — Presentation of results

Type of failure			Designation
C	P	N	
<i>x</i>	*	*	<i>x</i> C*
<i>x</i>	(P)	*	<i>x</i> C(P)
<i>x</i>	*	(N)	<i>x</i> C(N)
*	<i>x</i>	*	<i>x</i> P*
(C)	<i>x</i>	*	<i>x</i> P(C)
*	<i>x</i>	(N)	<i>x</i> P(N)
*	*	N	N*
(C)	*	N	N(C)
*	(P)	N	N(P)

x Mean value of impact strength for most frequent failure type, excluding type N.
 C, P or N Most frequent failure type.
 (C), (P) or (N) Second most frequent failure type, to be recorded only if its frequency is higher than 1/3.
 * Not relevant.

Annex A (informative)

Additional methods for investigating the influence of surface effects

The following additional methods (see [Table A.1](#)) with double V-notches can be used for materials described in [6.3.1](#).

If the influence of surface effects on moderate- or high-impact materials is to be measured, flatwise impact may be used with double V-notches. Two notches are made perpendicular to the line of impact. The length of each notch is h , as shown in [Figure A.1](#).

Table A.1 — Parameters for tests on double-notched specimens

Dimensions in millimetres

Method designation ^a	Specimen type	Blow direction	Notch type	Notch tip radius, r_N	Remaining width, b_N , at notch tip
			Double notch		
ISO 179-1/1fA	1	Flatwise	A	$0,25 \pm 0,05$	$6,0 \pm 0,2$
ISO 179-1/1fB	1	Flatwise	B	$1,00 \pm 0,05$	$6,0 \pm 0,2$
ISO 179-1/1fC	1	Flatwise	C	$0,10 \pm 0,02$	$6,0 \pm 0,2$

^a If specimens are taken from sheets or products, the thickness of the sheet or product shall be added to the designation.

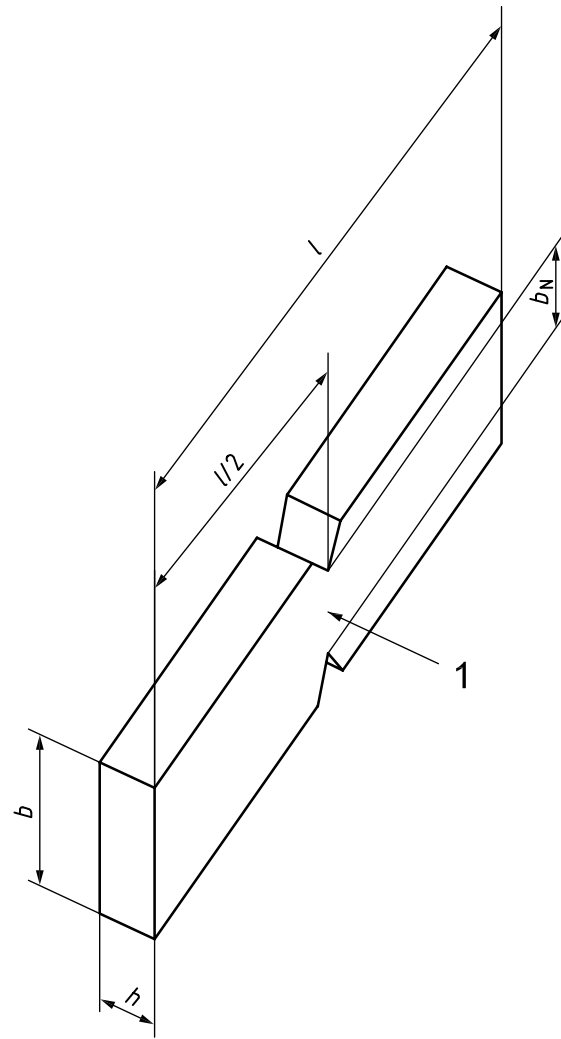

Key

1 direction of blow

Figure A.1 — Double-notched specimen

Annex B (informative)

Precision data

B.1 General

[Tables B.1](#) and [B.2](#) are based on interlaboratory tests performed in accordance with ASTM E691 using notched specimens. For each material, all the test bars were prepared by one source, except for notching. Notches were verified by the laboratory responsible for specimen distribution. [Tables B.1](#) and [B.2](#) are presented by analysis, day 1 and day 2. Each analysis is based on participating laboratories testing 10 specimens of each material. One specimen (determination) is a test result for calculating the statistics as per ASTM E691 statistical software.

[Table B.3](#) is based on interlaboratory tests organized by the Kunststoffinstitut Lüdenscheid, Germany, in accordance with ISO/IEC 17043 and ISO 13528 on unnotched specimens. The test results have been evaluated in accordance with ISO 5725-2. For each material, all test specimens were prepared by one single source. For all materials 3 test series have been performed on different days with 5 single measurements for each test series. Each test series was used as a test result for calculating the statistics as per ISO 5725-2 statistical software.

[Table B.1](#) is based on an interlaboratory test involving nine laboratories and three materials. [Table B.2](#) is based on an interlaboratory test involving seven laboratories and two materials. The laboratories and materials were grouped by the required velocity (2,9 m/s or 3,8 m/s) due to the difficulty in finding laboratories that had the necessary pendulums to carry out testing at both velocities.

NOTE The following explanations of r and R (see [Clause B.2](#)) are only intended to present a meaningful way of considering the approximate precision of this test method. The data in [Tables B.1](#), [B.2](#) and [B.3](#) are not intended to be rigorously applied to acceptance or rejection of material, as those data are specific to the interlaboratory test and might not be representative of other lots, conditions, materials or laboratories. Users of this test method are recommended to apply the principles of ASTM E691 and/or ISO 5725-2 to generate data specific to their laboratory and materials, or between specific laboratories. The principles of [Clause B.2](#) would then be valid for such data.

B.2 Concept of r and R

If s_r and s_R have been calculated from a large enough body of data, and for test results that were from one test determination, then:

For the **repeatability limit**, r (comparing two test results for the same material, obtained by the same operator using the same equipment on the same day), the two test results should be judged not equivalent if they differ by more than the r -value for that material.

For the **reproducibility limit**, R (comparing two results for the same material, obtained by different operators using different equipment on different days), the two test results should be judged not equivalent if they differ by more than the R -value for that material.

Any judgment in accordance with the above would have an approximately 95 % (0,95) probability of being correct

Repeatability limit, $r = 2,83 s_r$

Reproducibility limit, $R = 2,83 s_R$

Table B.1 — Precision data for Charpy impact strength of notched specimens (a_{cN}) at 2,9 m/s – ISO 179-1/1eA

All absolute values in kJ/m² and all relative values in % of the average

	Material	Average	s_r ^a	s_R ^b	rel s_r	rel s_R
Day 1	ABS	13,5	0,47	1,86	3,5 %	13,8 %
	PBT-GF	8,52	0,61	1,27	7,2 %	14,9 %
	Polypropylene	10,5	0,63	1,58	6,0 %	15,1 %
Day 2	ABS	13,4	0,45	1,90	3,3 %	14,1 %
	PBT-GF	8,54	0,60	1,29	7,0 %	15,1 %
	Polypropylene	10,8	0,65	1,45	6,0 %	13,4 %
^a s_r is the within-laboratory standard deviation.						
^b s_R is the between-laboratory standard deviation.						

Table B.2 — Precision data for Charpy impact strength of notched specimens (a_{cN}) at 3,8 m/s – ISO 179-1/1eA

All absolute values in kJ/m² and all relative values in % of the average

	Material	Average	s_r ^a	s_R ^b	rel s_r	rel s_R
Day 1	Polycarbonate	91,7	5,30	8,37	5,8 %	9,1 %
	Polyurethane	94,3	5,37	6,21	5,7 %	6,6 %
Day 2	Polycarbonate	91,7	3,85	6,49	4,2 %	7,1 %
	Polyurethane	92,4	6,32	7,86	6,8 %	8,5 %
^a s_r is the within-laboratory standard deviation.						
^b s_R is the between-laboratory standard deviation.						

Table B.3 — Precision data for Charpy impact strength of unnotched specimens (a_{cU}) – ISO 179-1/1eU

All absolute values in kJ/m² and all relative values in % of the average

Impact velocity	Material	Number of labs	Average	s_r ^a	s_R ^b	rel s_r	rel s_R
2,9 m/s	POM-GF	18	7,29	0,18	0,24	2,5 %	3,3 %
	POM	16	5,73	0,26	0,91	4,5 %	15,9 %
	ABS	11	17,0	0,40	0,90	2,4 %	5,3 %
3,8 m/s	PP-T	25	49,6	1,34	1,73	2,7 %	3,5 %
	PP-T20	18	46,8	0,99	1,21	2,1 %	2,6 %
	PP-GF	23	36,2	0,53	0,81	1,5 %	2,2 %
	PP	10	54,6	1,18	2,11	2,2 %	3,9 %
	PC/ABS	15	51,3	0,85	1,31	1,7 %	2,6 %
^a s_r is the within-laboratory standard deviation.							
^b s_R is the between-laboratory standard deviation.							

Annex C (informative)

Determining the notch tip radius using a CCD microscope

C.1 The Charpy test result is sometimes very sensitive to the radius of the notch tip. In such cases, it is necessary for the radius to be measured accurately. This annex illustrates the effect of notch tip radius on the Charpy impact strength and describes the CCD microscope method as a suitable way of measuring the notch radius.

C.2 Figure [C.1](#) shows the effect of the notch radius on the Charpy impact strength of four types of plastics material.

C.3 Table [C.1](#) compares three methods of determining the notch radius.

C.4 Figure [C.2](#) shows a CCD microscope and a view of a typical notch. The notch radius can be determined from measurements at three points, using [Formulae \(C.1\)](#) to [\(C.3\)](#):

$$x^2 + y^2 + ax + by + c = 0 \tag{C.1}$$

$$(x + a/2)^2 + (y + b/2)^2 = a^2/4 + b^2/4 - c \tag{C.2}$$

$$r_N = (a^2/4 + b^2/4 - c)^{1/2} \tag{C.3}$$

where

x and y are the x - and y -coordinates of a point;

a , b and c are constants;

r_N is the notch radius.

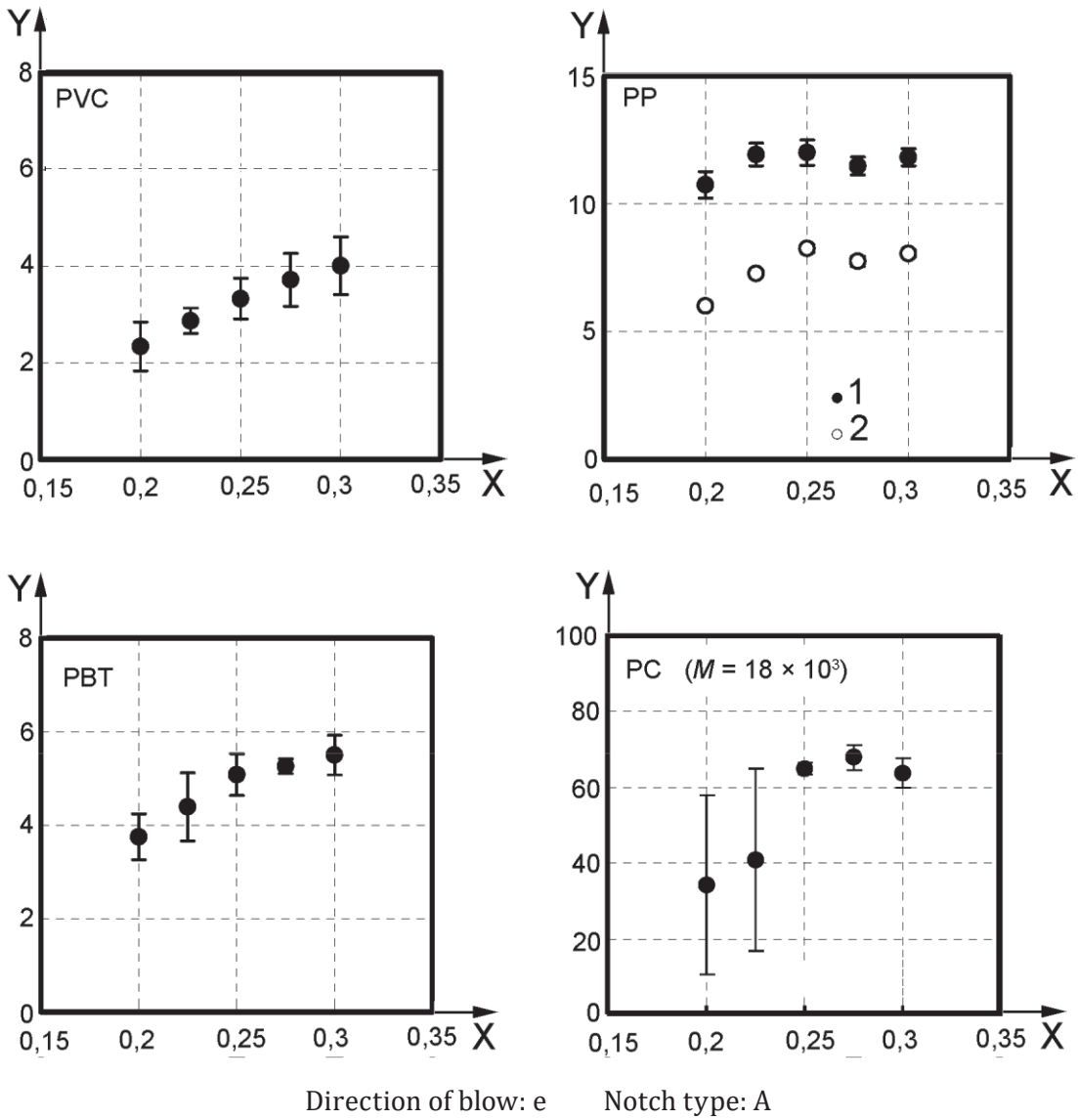

Key

- X notch tip radius (mm)
- Y impact strength (kJ/m²)
- 1 PP block copolymer
- 2 PP homopolymer

Figure C.1 — Effect of notch tip radius on Charpy impact strength

Table C.1 — Methods for determining the notch tip radius

Method	Principle	Determination	Procedure	Detection capability mm	Remarks
Digital-microscope method	Optical CCD microscope Simple, good precision	Digital	Notch profile obtained using CCD microscope (magnification $\times 100$ to $\times 600$). Radius calculated by digital processing (see C.4).	1/1 000	Operation is quick and simple. Superior depth of field is beneficial for 3D image measurement.
Comparator method (ASTM D6110)	Optical comparison with template Indirect method, not simple	Comparison	Magnified image compared with a transparent template (prepared in advance) to determine whether notch tip radius falls within a specified range.	1/100	Method does not determine actual value of radius.
Stylus instrument method	Physical outline trace of notch with needle Simple but affected by vibration	Digital	Stylus used to explore surface of specimen and acquire notch profile. Radius calculated by digital processing.	1/1 000	Stylus is susceptible to vibration. Burrs in notch can cause errors.

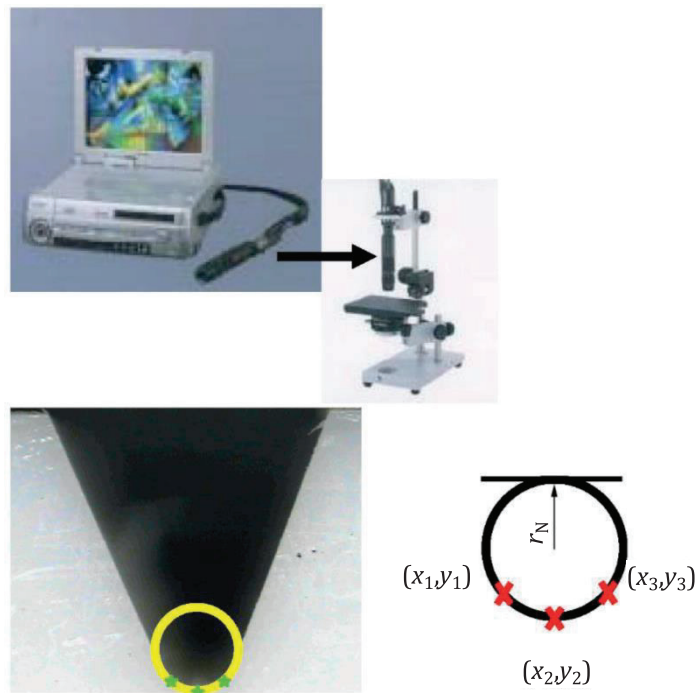

Figure C.2 — Typical CCD microscope and view of a typical notch

Bibliography

- [1] ISO 180, *Plastics — Determination of Izod impact strength*
- [2] ISO 2602, *Statistical interpretation of test results — Estimation of the mean — Confidence interval*
- [3] ISO 5725-2, *Accuracy (trueness and precision) of measurement methods and results — Part 2: Basic method for the determination of repeatability and reproducibility of a standard measurement method*
- [4] ISO 13528, *Statistical methods for use in proficiency testing by interlaboratory comparison*
- [5] ISO 16012, *Plastics — Determination of linear dimensions of test specimens*
- [6] ISO/IEC 17043, *Conformity assessment — General requirements for proficiency testing*
- [7] ISO 20753:—,¹⁾*Plastics — Test specimens*
- [8] ASTM D6110, *Standard Test Method for Determining the Charpy Impact Resistance of Notched Specimens of Plastics*
- [9] ASTM E691, *Standard Practice for Conducting an Interlaboratory Study to Determine the Precision of a Test Method*

1) Under preparation. Stage at the time of publication: ISO/DIS 20753:2023.

