Infusion equipment for medical use —
Part 8:
Infusion sets for single use with
pressure infusion apparatus

Matériel de perfusion à usage médical —

*Partie 8: Appareils de perfusion non réutilisables avec des appareils
de perfusion sous pression*





COPYRIGHT PROTECTED DOCUMENT

© ISO 2015, Published in Switzerland

All rights reserved. Unless otherwise specified, no part of this publication may be reproduced or utilized otherwise in any form or by any means, electronic or mechanical, including photocopying, or posting on the internet or an intranet, without prior written permission. Permission can be requested from either ISO at the address below or ISO's member body in the country of the requester.

ISO copyright office
Ch. de Blandonnet 8 • CP 401
CH-1214 Vernier, Geneva, Switzerland
Tel. +41 22 749 01 11
Fax +41 22 749 09 47
copyright@iso.org
www.iso.org

Contents

	Page
Foreword	iv
1 Scope	1
2 Normative references	1
3 Terms and definitions	1
4 General requirements	2
5 Materials	5
6 Physical requirements	5
6.1 Particulate contamination.....	5
6.2 Tensile strength.....	5
6.3 Leakage.....	5
6.4 Male conical fitting.....	6
6.5 Injection site.....	6
6.6 Fluid filter.....	6
6.7 Flow rate of infusion fluid.....	6
6.8 Closure-piercing device.....	6
6.9 Air-inlet device.....	6
6.10 Drip chamber and drip tube.....	6
6.11 Tubing.....	6
6.12 Flow regulator.....	6
6.13 Protective caps.....	6
6.14 Storage volume.....	6
7 Chemical requirements	6
8 Biological requirements	6
9 Packaging	7
10 Labelling	7
10.1 General.....	7
10.2 Label on unit container.....	7
10.3 Label on shelf or multi-unit container.....	7
11 Disposal	8
Annex A (normative) Physical tests	9
Annex B (normative) Storage volume	10
Bibliography	13

Foreword

ISO (the International Organization for Standardization) is a worldwide federation of national standards bodies (ISO member bodies). The work of preparing International Standards is normally carried out through ISO technical committees. Each member body interested in a subject for which a technical committee has been established has the right to be represented on that committee. International organizations, governmental and non-governmental, in liaison with ISO, also take part in the work. ISO collaborates closely with the International Electrotechnical Commission (IEC) on all matters of electrotechnical standardization.

The procedures used to develop this document and those intended for its further maintenance are described in the ISO/IEC Directives, Part 1. In particular the different approval criteria needed for the different types of ISO documents should be noted. This document was drafted in accordance with the editorial rules of the ISO/IEC Directives, Part 2 (see www.iso.org/directives).

Attention is drawn to the possibility that some of the elements of this document may be the subject of patent rights. ISO shall not be held responsible for identifying any or all such patent rights. Details of any patent rights identified during the development of the document will be in the Introduction and/or on the ISO list of patent declarations received (see www.iso.org/patents).

Any trade name used in this document is information given for the convenience of users and does not constitute an endorsement.

For an explanation on the meaning of ISO specific terms and expressions related to conformity assessment, as well as information about ISO's adherence to the WTO principles in the Technical Barriers to Trade (TBT) see the following URL: [Foreword - Supplementary information](#)

The committee responsible for this document is ISO/TC 76, *Transfusion, infusion and injection, and blood processing equipment for medical and pharmaceutical use*.

This second edition cancels and replaces the first edition (ISO 8536-8:2004), which has been technically revised with the following changes:

- The part title has been changed from 'Infusion equipment ...' to 'Infusion sets ...';
- The former Clause 4 on designation has been deleted;
- [6.14](#) has been amended and an appropriate [Annex B](#) 'Storage volume' added;
- [Clause 10](#) on labelling was amended by a note regarding the usage of the symbol "XXX" according ISO 7000-2725;
- [Clause 11](#) on disposal has been added;
- [A.3](#) 'Tests for leakage' has been amended;
- The former A.4 specifying a test of male conical fitting for leakage has been deleted;
- Normative references and the Bibliography have been updated;
- Document has been editorially revised.

ISO 8536 consists of the following parts, under the general title *Infusion equipment for medical use*:

- *Part 1: Infusion glass bottles*
- *Part 2: Closures for infusion bottles*
- *Part 3: Aluminium caps for infusion bottles*
- *Part 4: Infusion sets for single use, gravity feed*

- *Part 5: Burette infusion sets for single use, gravity feed*
- *Part 6: Freeze drying closures for infusion bottles*
- *Part 7: Caps made of aluminium-plastics combinations for infusion bottles*
- *Part 8: Infusion sets for single use with pressure infusion apparatus*
- *Part 9: Fluid lines for single use with pressure infusion equipment*
- *Part 10: Accessories for fluid lines for single use with pressure infusion equipment*
- *Part 11: Infusion filters for single use with pressure infusion equipment*
- *Part 12: Check valves*

The following parts are under preparation:

- *Part 13: Graduated flow regulators for single use with infusion sets*
- *Part 14: Clamps and flow regulators for transfusion and infusion equipment without fluid contact*

Infusion equipment for medical use —

Part 8:

Infusion sets for single use with pressure infusion apparatus

1 Scope

This part of ISO 8536 gives users information on sterilized infusion sets for single use with pressure infusion apparatus up to a maximum of 200 kPa (2 bar).

In some countries, the national pharmacopoeia or other national regulations are legally binding and take precedence over this part of ISO 8536.

2 Normative references

The following documents, in whole or in part, are normatively referenced in this document and are indispensable for its application. For dated references, only the edition cited applies. For undated references, the latest edition of the referenced document (including any amendments) applies.

ISO 594-2¹⁾, *Conical fittings with 6 % (Luer) taper for syringes, needles and certain other medical equipment — Part 2: Lock fittings*

ISO 7000, *Graphical symbols for use on equipment — Registered symbols*

ISO 8536-4, *Infusion equipment for medical use — Part 4: Infusion sets for single use, gravity feed*

ISO 15223-1, *Medical devices — Symbols to be used with medical device labels, labelling and information to be supplied — Part 1: General requirements*

3 Terms and definitions

For the purposes of this document, the following terms and definitions apply.

NOTE These terms and definitions are specifically applicable to [Annex B](#).

3.1 filling volume

V_F

volume of tube during „pressure less“-filling respectively filling by gravity, the tube remains unstressed

Note 1 to entry: The filling volume is to be equated with the calculated volume of the tube.

3.2 storage volume

V_S

tube volume during pressurization equal to filling volume (V_F) plus bolus volume (V_B):

$$V_S = V_F + V_B$$

1) To be replaced by ISO 80369-7.

3.3 bolus volume

V_B
 increased tube volume during pressurization (storage volume V_S) in comparison to the unstressed tube (filling volume V_F)

Note 1 to entry: For illustration of the bolus volume see [Figure 1](#).

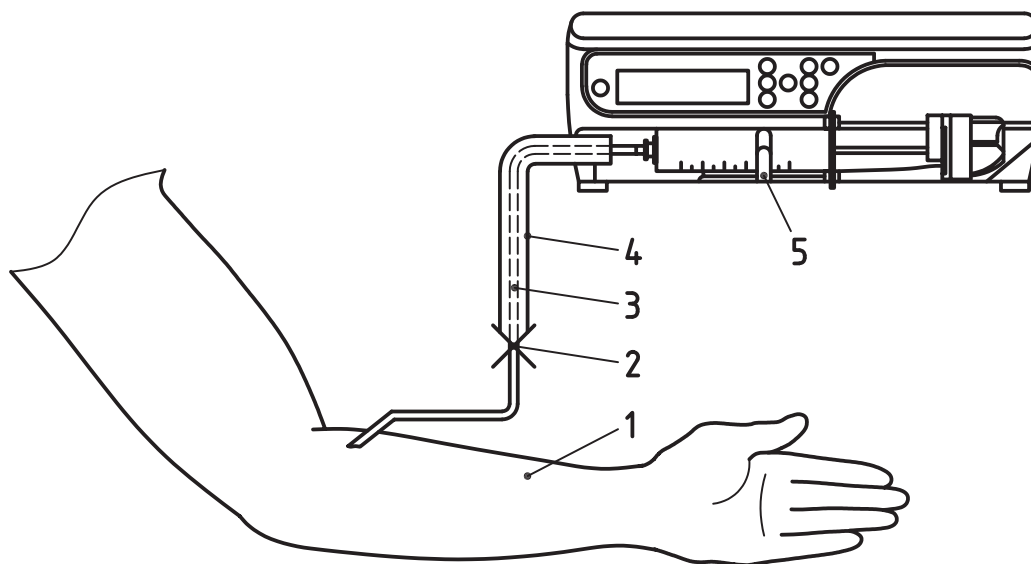

Key			
1	patient	4	bolus volume
2	occlusion	5	syringe pump
3	tube		

Figure 1 — Bolus volume

4 General requirements

4.1 The nomenclature to be used for components of infusion sets and of a separate air-inlet device is given in [Figures 2, 3, and 4](#). These figures illustrate examples of the configuration of infusion sets and air-inlet devices; other configurations may be used provided they lead to the same results. Infusion sets as illustrated in [Figure 3](#) should only be used for collapsible plastics containers. Infusion sets as illustrated in [Figure 3](#) used with separate air-inlet devices as illustrated in [Figure 4](#), or infusion sets as illustrated in [Figure 2](#) shall be used for rigid containers.

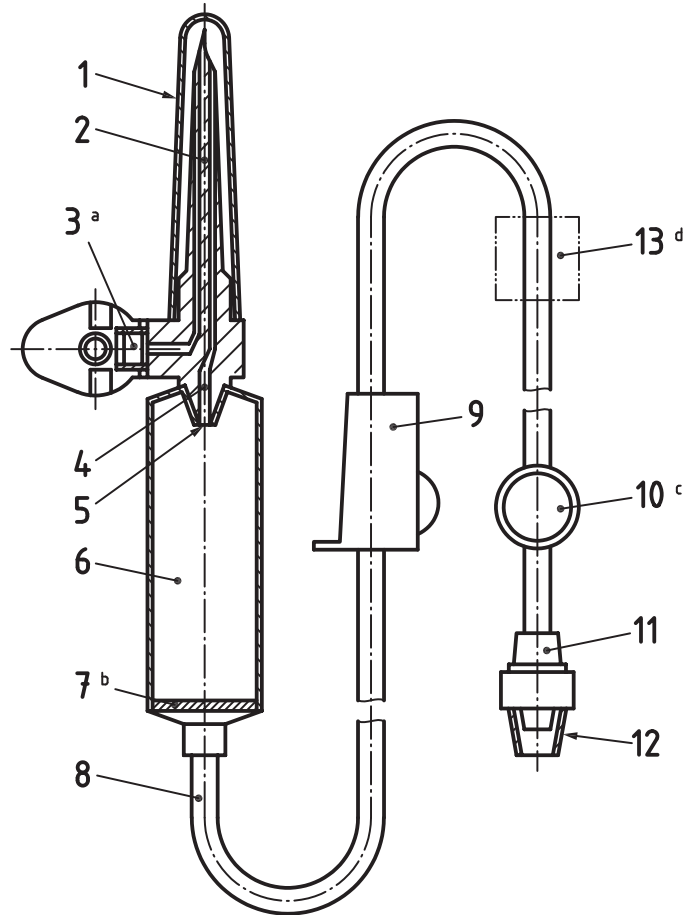

Key

- | | |
|---|---|
| 1 protective cap of closure-piercing device | 8 tubing |
| 2 closure-piercing device | 9 flow regulator |
| 3 air-inlet with air filter and closure | 10 injection site |
| 4 fluid channel | 11 male conical fitting |
| 5 drip tube | 12 protective cap of male conical fitting |
| 6 drip chamber | 13 flow element |
| 7 fluid filter | |
| a Closure of air inlet is optional. | |
| b The fluid filter may be positioned at other sites, preferably near the patient access. Generally, the fluid filter used has a nominal pore size of 15 μm . | |
| c Injection site is optional. | |
| d Optional element of infusion set which interfaces with pressure infusion apparatus. | |

Figure 2 — Example of a vented infusion set

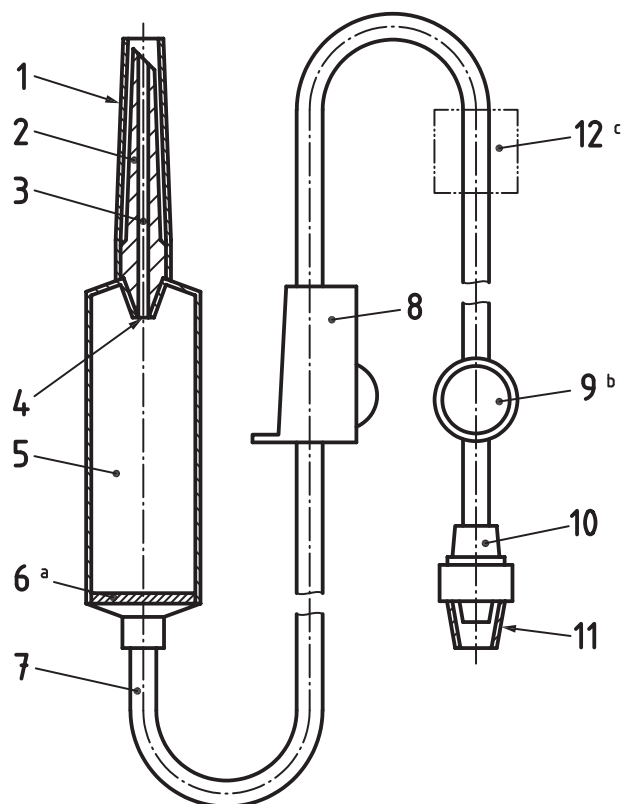

Key

- | | |
|---|---|
| 1 protective cap of the closure-piercing device | 7 tubing |
| 2 closure-piercing device | 8 flow regulator |
| 3 fluid channel | 9 injection site |
| 4 drip tube | 10 male conical fitting |
| 5 drip chamber | 11 protective cap of male conical fitting |
| 6 fluid filter | 12 flow element |

a The fluid filter may be positioned at other sites, preferably near the patient access. Generally, the fluid filter used has a nominal pore size of 15 µm.

b Injection site is optional.

c Optional element of infusion set which interfaces with pressure infusion apparatus.

Figure 3 — Example of a non-vented infusion set

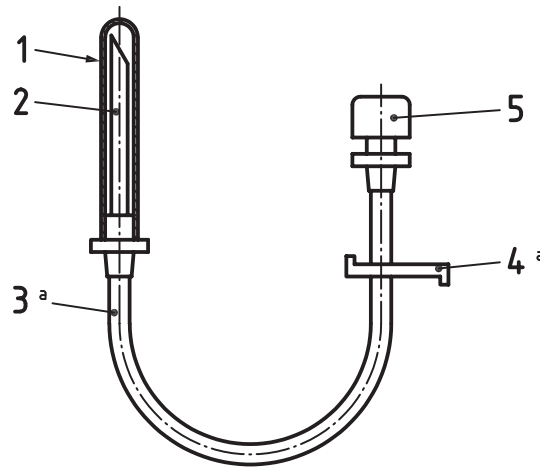

Key

- | | |
|--|-----------------------------|
| 1 protective cap | 4 clamp |
| 2 closure-piercing device or needle | 5 air-inlet with air filter |
| 3 tubing | |
| a Other designs are acceptable if the same safety aspects are ensured. | |

Figure 4 — Example of an air-inlet device

4.2 The infusion set shall be provided with protective caps to maintain sterility of the internal parts of the set until the set is used. The air-inlet device shall be provided with a protective cap over the closure-piercing device or needle.

5 Materials

The materials from which the infusion set and its components are manufactured shall comply with the requirements as specified in [Clause 6](#). Where components of the infusion set come into contact with the infusion solution, the materials additionally shall comply with the requirements as specified in [Clause 7](#) and [Clause 8](#).

6 Physical requirements

6.1 Particulate contamination

ISO 8536-4 applies.

6.2 Tensile strength

When tested as specified in [A.2](#), the infusion set, excluding protective caps, shall withstand a static tensile force of not less than 15 N for 15 s.

6.3 Leakage

The infusion set shall be impermeable to air, microorganisms and fluids.

Neither air nor water shall escape when tested according to [A.3.2](#) and [A.3.4](#), and no air shall enter when tested according to [A.3.3](#).

6.4 Male conical fitting

The male conical fitting must be in accordance with ISO 594-2.

6.5 Injection site

The injection site shall enable injection into the tubing. There shall be no leakage of more than one falling drop of water when tested according to [A.4](#).

6.6 Fluid filter

ISO 8536-4 applies.

6.7 Flow rate of infusion fluid

ISO 8536-4 applies.

6.8 Closure-piercing device

ISO 8536-4 applies.

6.9 Air-inlet device

ISO 8536-4 applies.

6.10 Drip chamber and drip tube

ISO 8536-4 applies.

6.11 Tubing

ISO 8536-4 applies.

6.12 Flow regulator

ISO 8536-4 applies.

6.13 Protective caps

ISO 8536-4 applies.

6.14 Storage volume

The storage volume shall be stated according to [10.2](#) i). For a definition of the storage volume and for a test method for the determination of the storage volume see [Annex B](#).

7 Chemical requirements

ISO 8536-4 applies.

8 Biological requirements

ISO 8536-4 applies.

9 Packaging

ISO 8536-4 applies.

10 Labelling

10.1 General

The labelling shall include the requirements as specified in [10.2](#) and [10.3](#). If graphical symbols are used, then refer to ISO 15223-1.

NOTE The presence of substances of interest can be indicated by using symbol 2725 of ISO 7000 by replacing the "XXX" by the abbreviation of the substance. The absence of substances of interest can be indicated by crossing the respective symbol.

10.2 Label on unit container

The unit container shall be labelled at least with the following information:

- a) the name and address of the manufacturer;
- b) a textual description of the contents;
- c) indication that the infusion set is free from pyrogens, or that the infusion set is free from bacterial endotoxins;
- d) indication that the infusion set is sterile, using the graphical symbol as given in ISO 15223-1;
- e) the lot (batch) designation, prefixed by the word LOT, or using the graphical symbol according to ISO 15223-1;
- f) year and month of expiry, accompanied by appropriate wording or the graphical symbol according to ISO 15223-1;
- g) indication that the infusion set is for single use only, or equivalent wording, or using the graphical symbol according to ISO 15223-1;
- h) instructions for use, including warnings, e.g. about detached protective caps (instructions for use may also take the form of an insert);
- i) the storage volume shall be labelled according [B.3](#). In case of dedicated infusion sets the name and type of pressure infusion apparatus shall be additionally given by the manufacturer;
- j) the letter "P", which stands for pressure, and whose type height shall stand out clearly from surrounding text;
- k) a statement that 20 drops of distilled water using an usual drip chamber or 60 drops of distilled water using a drip chamber with a micro drip tube are equivalent to a volume of $(1 \pm 0,1)$ ml or a mass of $(1 \pm 0,1)$ g.

If the available space is too small to give all this information in legible characters and/or symbols, the information may be reduced to e) and f). In this case the information as required in this subclause shall be given on the label of the next bigger shelf or multi-unit container.

10.3 Label on shelf or multi-unit container

The shelf or multi-unit container shall be labelled at least with the following information:

- a) the name and address of the manufacturer;
- b) a textual description of the contents;

- c) the lot (batch) designation, prefixed by the word LOT, or using the graphical symbol according to ISO 15223-1;
- d) year and month of expiry, accompanied by appropriate wording or the graphical symbol according to ISO 15223-1;
- e) instructions for use, including warnings, e.g. about detached protective caps (instructions for use may also take the form of an insert);
- f) the letter “P”, which stands for pressure, and whose type height shall stand out clearly from surrounding text;
- g) storage note.

11 Disposal

Information for a secure and environmentally sound disposal of single-use infusion sets should be given.

EXAMPLE “Always dispose of blood contaminated products in a manner consistent with established biohazard procedures.”

Annex A **(normative)**

Physical tests

A.1 Test for particulate contamination

ISO 8536-4 applies.

A.2 Test of tensile strength

Expose the infusion set to be tested to a static tensile force of 15 N applied along the longitudinal axis for 15 s. Inspect whether the infusion set withstands the test force applied.

A.3 Tests for leakage

A.3.1 In the beginning of the test the whole system shall be conditioned at the test temperature.

A.3.2 Connect the infusion set with the air supply and close all other openings. Apply air with an internal excess pressure of 50 kPa to the infusion set for 15 s. Inspect the infusion set for any leakage of air under water at (40 ± 1) °C.

A.3.3 Fill the infusion set with distilled water at (40 ± 1) °C, connect it with its openings sealed to a vacuum device and subject it to an internal excess pressure of -20 kPa for 15 s. Inspect whether air enters the upstream section of the infusion set.

This test is only applicable to the upstream section of the infusion set.

A.3.4 The downstream water-filled section of the infusion set including its flow element is tested for 15 min under internal excess pressure of 200 kPa. In case of dedicated sets the maximum operation pressure of the infusion pump shall be applied. Inspect for any leakage of water at (40 ± 1) °C.

NOTE For infusion sets which do not have a flow element the entire tubing up to a point just below the drip chamber is tested under identical conditions.

A.4 Test of injection site

Perform according to ISO 8536-4, but under internal excess pressure of 200 kPa.

A.5 Test for efficiency of the fluid filter

ISO 8536-4 applies.

Annex B (normative)

Storage volume

B.1 General

This Annex clarifies the different measurable tube volumes by providing a clear definition and a test method for the determination of each of the volumes.

B.2 Determination of tube volumes

B.2.1 Filling volume (V_F)

The filling volume of the tube is solely calculated. The calculation is effected with the nominal inner diameter of the tube according to Formula (B.1).

$$V_F = \frac{d^2 \cdot \pi \cdot l}{4} \quad (\text{B.1})$$

where

d is the nominal inner diameter of the tube;

l is the length of the tube.

B.2.2 Bolus volume (V_B)

B.2.2.1 General

The bolus volume is difficult to be determined only by calculation considering all variables e.g. inner diameter, wall thickness, hardness of tube, temperature influence. Therefore, determination of the bolus volume is made according to the following test conditions (see also [Figure B.1](#)):

- room temperature (23 ± 2) °C;
- test medium distilled water, temperature of test medium (40 ± 1) °C;
- internal excess pressure of 200 kPa. In case of dedicated sets the maximum operation pressure of the infusion pump shall be applied. Duration of pressurization 15 s;
- all test samples are in a ready for use condition, e.g. sterile;
- length of tube 2 000 mm plus connectors;
- for “rigid” connectors, the volume difference under pressurization is zero.

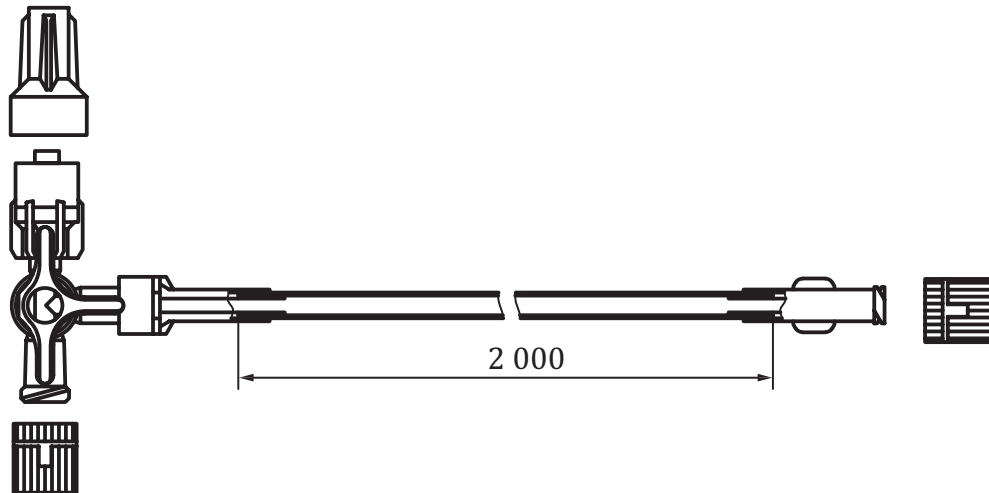

Figure B.1 — Test apparatus for determination of the bolus volume

B.2.2.2 Procedure

For the determination of the bolus volume the following procedural steps have to be performed.

- a) Filling of test sample without air-bubbles with test medium;
- b) Occlusion of tube outlet with closure plug and the tube inlet by turning the 3-way stopcock;
- c) Determine weight of the test sample filled without pressure = M_1 ;
- d) Open the 3-way stopcock, apply the test pressure (fluid pressure) to the 3-way stopcock, wait until test pressure has stabilized and maintain it for 15 s, then close the 3-way stopcock;
- e) Determine weight of the test sample filled with pressure = M_2 ;
- f) Calculation of bolus volume (V_B) by means of weight difference (1 g = 1 ml), as given in Formula (B.2):

$$V_B = \frac{M_2 - M_1}{l} \quad (\text{B.2})$$

where

M_1 is the weight without pressure;

M_2 is the weight with pressure;

l length of the tube.

B.2.3 Storage volume (V_S)

The storage volume of the tube is calculated by addition of the filling volume (V_F) and the bolus volume (V_B), as shown in Formula (B.3):

$$V_S = V_F + V_B \quad (\text{B.3})$$

B.3 Labelling

Due to the term definition of filling volume, storage volume and bolus volume not being known to every user, these terms have been replaced by the general information, VOL' (volume). This is supplemented by an indication of temperature and pressure conditions. The information given always refers to a tube

length of 1 m to facilitate a simple conversion and/or calculation for the user in case of a partial occlusion. An example for labelling is given in [Figure B.2](#).

- accuracy of volume specification: 1 ml;
- design of specification.

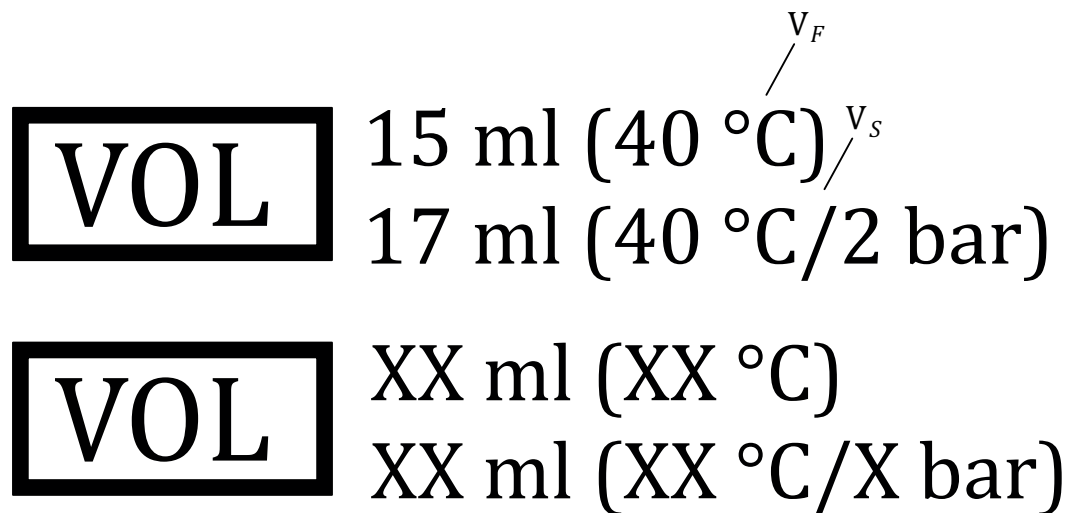

Figure B.2 — Example for labelling

Bibliography

- [1] ISO 8536-9, *Infusion equipment for medical use — Part 9: Fluid lines for single use with pressure infusion equipment*
- [2] ISO 10993-4, *Biological evaluation of medical devices — Part 4: Selection of tests for interactions with blood*
- [3] ISO 11135-1, *Sterilization of health care products — Ethylene oxide — Part 1: Requirements for development, validation and routine control of a sterilization process for medical devices*
- [4] ISO 11137-1, *Sterilization of health care products — Radiation — Part 1: Requirements for development, validation and routine control of a sterilization process for medical devices*
- [5] ISO 11137-2, *Sterilization of health care products — Radiation — Part 2: Establishing the sterilization dose*
- [6] ISO 17665-1, *Sterilization of health care products — Moist heat — Part 1: Requirements for the development, validation and routine control of a sterilization process for medical devices*
- [7] EN 15986, *Symbol for use in the labelling of medical devices — Requirements of medical devices containing phthalates*
- [8] European Pharmacopoeia
- [9] United States Pharmacopeia
- [10] Japanese Pharmacopoeia

