

INTERNATIONAL  
STANDARD

ISO  
9333

Third edition  
2022-08

---

---

**Dentistry — Brazing materials**

*Médecine bucco-dentaire — Produits pour brasage*



Reference number  
ISO 9333:2022(E)

© ISO 2022



**COPYRIGHT PROTECTED DOCUMENT**

© ISO 2022

All rights reserved. Unless otherwise specified, or required in the context of its implementation, no part of this publication may be reproduced or utilized otherwise in any form or by any means, electronic or mechanical, including photocopying, or posting on the internet or an intranet, without prior written permission. Permission can be requested from either ISO at the address below or ISO's member body in the country of the requester.

ISO copyright office  
CP 401 • Ch. de Blandonnet 8  
CH-1214 Vernier, Geneva  
Phone: +41 22 749 01 11  
Email: [copyright@iso.org](mailto:copyright@iso.org)  
Website: [www.iso.org](http://www.iso.org)

Published in Switzerland

# Contents

	Page
<b>Foreword</b> .....	<b>v</b>
<b>1 Scope</b> .....	<b>1</b>
<b>2 Normative references</b> .....	<b>1</b>
<b>3 Terms and definitions</b> .....	<b>1</b>
<b>4 Requirements</b> .....	<b>2</b>
4.1 Chemical composition.....	2
4.1.1 Metallic materials to be joined.....	2
4.1.2 Reported composition.....	2
4.1.3 Permitted deviation from the reported composition.....	2
4.1.4 Hazardous elements.....	2
4.2 Biocompatibility.....	2
4.3 Mechanical tensile strength of brazed joints.....	2
4.4 Corrosion resistance.....	3
4.4.1 Static immersion test.....	3
4.4.2 Appearance after corrosion exposure.....	3
4.5 Melting range.....	3
<b>5 Sampling</b> .....	<b>3</b>
<b>6 Preparation of specimens</b> .....	<b>3</b>
6.1 General.....	3
6.1.1 Test specimen.....	3
6.1.2 Casting.....	3
6.1.3 Other methods.....	4
6.1.4 Treatment of specimens.....	4
6.2 Specimens for corrosion testing.....	4
6.2.1 General.....	4
6.2.2 Procedure.....	4
6.3 Specimens for tensile testing.....	4
6.3.1 General.....	4
6.3.2 Procedure.....	4
6.3.3 Additional testing.....	5
<b>7 Measurement and test methods</b> .....	<b>6</b>
7.1 Visual inspection.....	6
7.1.1 Specimens.....	6
7.1.2 Instruction for use, packaging and labelling.....	6
7.2 Chemical composition.....	6
7.3 Tensile testing.....	6
7.3.1 Apparatus.....	6
7.3.2 Test procedure.....	6
7.3.3 Evaluation of the tensile test results.....	7
7.4 Corrosion resistance.....	7
7.4.1 General.....	7
7.4.2 Analysis.....	7
7.4.3 Microscopic inspection.....	7
7.4.4 Corrosion test report.....	7
7.5 Melting range.....	8
<b>8 Test report</b> .....	<b>8</b>
<b>9 Instruction for use</b> .....	<b>8</b>
<b>10 Marking and labelling</b> .....	<b>9</b>
10.1 Marking.....	9
10.2 Labelling.....	9
10.3 Packaging.....	9

**Bibliography** ..... **10**

## Foreword

ISO (the International Organization for Standardization) is a worldwide federation of national standards bodies (ISO member bodies). The work of preparing International Standards is normally carried out through ISO technical committees. Each member body interested in a subject for which a technical committee has been established has the right to be represented on that committee. International organizations, governmental and non-governmental, in liaison with ISO, also take part in the work. ISO collaborates closely with the International Electrotechnical Commission (IEC) on all matters of electrotechnical standardization.

The procedures used to develop this document and those intended for its further maintenance are described in the ISO/IEC Directives, Part 1. In particular, the different approval criteria needed for the different types of ISO documents should be noted. This document was drafted in accordance with the editorial rules of the ISO/IEC Directives, Part 2 (see [www.iso.org/directives](http://www.iso.org/directives)).

Attention is drawn to the possibility that some of the elements of this document may be the subject of patent rights. ISO shall not be held responsible for identifying any or all such patent rights. Details of any patent rights identified during the development of the document will be in the Introduction and/or on the ISO list of patent declarations received (see [www.iso.org/patents](http://www.iso.org/patents)).

Any trade name used in this document is information given for the convenience of users and does not constitute an endorsement.

For an explanation of the voluntary nature of standards, the meaning of ISO specific terms and expressions related to conformity assessment, as well as information about ISO's adherence to the World Trade Organization (WTO) principles in the Technical Barriers to Trade (TBT), see [www.iso.org/iso/foreword.html](http://www.iso.org/iso/foreword.html).

This document was prepared by Technical Committee ISO/TC 106, *Dentistry*, Subcommittee SC 2, *Prosthetic materials*, in collaboration with the European Committee for Standardization (CEN) Technical Committee CEN/TC 55, *Dentistry*, in accordance with the Agreement on technical cooperation between ISO and CEN (Vienna Agreement).

This third edition cancels and replaces the second edition (ISO 9333:2006), which has been technically revised.

The main changes are as follows:

- the brazing materials with silver as the main component have been excluded from the scope;
- the definitions in [Clause 3](#) have been clarified and harmonized with ISO 22674;
- the corrosion requirements in [4.4](#) have been harmonized with ISO 22674 and ISO 10271;
- the analysis of corrosion elements has been added as a requirement in [7.4.2](#);
- the melting range requirements ([7.5](#)) have been harmonized with ISO 22674;
- a requirement for a test report has been added as a new [Clause 8](#);
- the IFU requirement for a working temperature has been added in [Clause 9](#);
- the labelling requirement for marking of working temperature has been added in [Clause 10](#) as optional.

Any feedback or questions on this document should be directed to the user's national standards body. A complete listing of these bodies can be found at [www.iso.org/members.html](http://www.iso.org/members.html).



# Dentistry — Brazing materials

## 1 Scope

This document specifies the requirements and test methods for dental brazing materials suitable for use in metallic restorations.

Brazing materials with silver as the main component are excluded from this document.

## 2 Normative references

The following documents are referred to in the text in such a way that some or all of their content constitutes requirements of this document. For dated references, only the edition cited applies. For undated references, the latest edition of the referenced document (including any amendments) applies.

ISO 1942, *Dentistry — Vocabulary*

ISO 6344-3, *Coated abrasives — Determination and designation of grain size distribution — Part 3: Microgrit sizes P240 to P5000*

ISO 10271:2020, *Dentistry — Corrosion test methods for metallic materials*

ISO 15223-1:2021, *Medical devices — Symbols to be used with information to be supplied by the manufacturer — Part 1: General requirements*

ISO 22674:2022, *Dentistry — Metallic materials for fixed and removable restorations and appliances*

## 3 Terms and definitions

For the purposes of this document, the terms and definitions given in ISO 1942, ISO 22674 and the following apply.

ISO and IEC maintain terminology databases for use in standardization at the following addresses:

- ISO Online browsing platform: available at <https://www.iso.org/obp>
- IEC Electropedia: available at <https://www.electropedia.org/>

### 3.1

#### **brazing material**

alloy suitable for use as a filler material in operations in which dental alloy parts are joined by brazing to form dental appliances and restorations

Note 1 to entry: The process and principle of brazing are identical to soldering. Brazing is done at higher temperatures than soldering.

### 3.2

#### **flux**

chemical cleaning, flowing or purifying agent that supports the flow of the molten *brazing material* (3.1) to wet the substrate

### 3.3

#### **working temperature**

temperature based on the liquidus temperature plus  $x$  [whereby  $x$  is given by the manufacturer of the *brazing material* (3.1)]

## 4 Requirements

### 4.1 Chemical composition

#### 4.1.1 Metallic materials to be joined

The metallic materials to be joined shall conform to ISO 22674:2022, 5.1 and 5.2.

#### 4.1.2 Reported composition

For all elements that are present in excess of mass fraction of 1,0 %, each constituent element shall be declared by the manufacturer and shall be reported to a precision of a mass fraction of 0,1 %.

Any element that is present in excess of mass fraction of 0,1 %, and with a lower or equal mass fraction of 1,0 %, shall be identified either by name or symbol.

#### 4.1.3 Permitted deviation from the reported composition

The permitted deviation of the reported composition for elements from the value stated on the package or label or insert is given in [Table 1](#).

**Table 1 — Permitted deviation from the reported composition for elements**

Alloy	Elemental content	
	1,0 % < $w$ ≤ 20 %	$w$ > 20 %
Base-metal alloy	maximum 1,0 %	maximum 2,0 %
Noble metal alloy	maximum 0,5 %	maximum 0,5 %
<b>Key</b>		
$w$ : mass fraction		

#### 4.1.4 Hazardous elements

##### 4.1.4.1 Recognized hazardous elements

For the purposes of this document the elements nickel, cadmium, beryllium and lead are designated to be hazardous elements.

##### 4.1.4.2 Permitted limits for hazardous elements

The brazing material shall contain no more than a mass fraction of 0,02 % of cadmium, beryllium or lead. If the brazing material contains more than a mass fraction of 0,1 % of nickel, the percentage shall not exceed the amount indicated on the package, label or insert.

## 4.2 Biocompatibility

Specific qualitative and quantitative requirements for freedom from biological hazard are not included in this document, but it is recommended that, in assessing possible biological hazards, reference should be made to ISO 10993-1 and ISO 7405.

## 4.3 Mechanical tensile strength of brazed joints

If the 0,2 % proof strength of both of the metallic materials to be joined by brazing is more than 250 MPa, the tensile strength of brazed specimens shall be at least 250 MPa.

If the 0,2 % proof strength of either one or both of the metallic materials to be joined by brazing is below 250 MPa, the tensile strength shall exceed the lower 0,2 % proof strength of the two.



Test in accordance with [7.3](#).

## 4.4 Corrosion resistance

### 4.4.1 Static immersion test

When pieces of a single metallic material are joined, the release of metal ions shall not exceed 200 µg/cm<sup>2</sup> in a time period of 7 d ± 1 h.

The metallic materials to be brazed shall conform to ISO 22674:2022, 5.7.

Test in accordance with [7.4](#).

### 4.4.2 Appearance after corrosion exposure

Magnified visual comparison prior to and after corrosion testing shall not reveal any visible selective corrosion (visible evidence that a chemical reaction has occurred) in the vicinity of the brazing of the tested specimen.

Test in accordance with [7.4](#).

## 4.5 Melting range

The solidus temperature and the liquidus temperature of the brazing material shall be within ±20 °C of the values given in the instructions for use.

Test in accordance with [7.5](#).

## 5 Sampling

The brazing material shall be from one lot. The amount of test material shall be sufficient to prepare the specimens required in [6.2](#) and [6.3](#), including a provision for a second set for tensile testing.

Further samples and packaging materials shall be made available for inspection in accordance with [10.2](#).

## 6 Preparation of specimens

### 6.1 General

#### 6.1.1 Test specimen

The test specimens consist of the metallic materials joined with the brazing material according to the instruction for use.

#### 6.1.2 Casting

For casting alloys to be tested, prepare the test specimens by the “lost wax process” of investment casting. Methods other than casting can be recommended by the manufacturer for the metallic material to be tested for suitability with the brazing materials. Use such a method, if recommended by the manufacturer. Follow the instructions for use relating to the processing of the metallic material(s) and the brazing material including the use of necessary aids, casting and brazing equipment.

### 6.1.3 Other methods

Methods other than casting, including additive and subtractive CAD/CAM procedures, can be recommended by the manufacturer for the metallic material to be tested for suitability with the brazing materials.

### 6.1.4 Treatment of specimens

Specimens with visible defects shall be discarded and replaced. Specimens shall be separated from sprues, casting beads, runners, fins and other projections. Surface contaminations shall be removed.

The specimens shall be in the metallurgical state(s) appropriate to their intended application(s).

If a heat-treatment is recommended by the manufacturer, perform the tests in the heat-treated state in accordance with the instruction for use.

If brazing is recommended after ceramic firing, the simulated ceramic firing of the specimens shall be in accordance with ISO 22674:2022, 7.2.3 and shall be applied before or after brazing.

## 6.2 Specimens for corrosion testing

### 6.2.1 General

Prepare two pieces of the metallic material(s) of dimensions approximately 34 mm × 13 mm × 1,5 mm and clean the surfaces. Cut the samples in half (17 mm × 13 mm × 1,5 mm).

Use two halves of the pieces for brazing. If two different metallic materials are to be brazed, use one of each for the two halves. Set the gap between the cut pieces at  $(0,2 \pm 0,1)$  mm.

### 6.2.2 Procedure

Use the recommended flux and follow the instruction for use for brazing. After the brazing process, remove at least 0,1 mm from all surfaces of the specimens using standard metallographic procedures ending with wet silicon carbide paper of grade P1200 in accordance with ISO 6344-3. Use the same piece of grinding paper solely for the preparation of specimens of the same composition.

For brazing of two different alloys use the same piece of grinding paper solely for the preparation of the specimens.

The total surface area of the sample shall be at least 10 cm<sup>2</sup> after preparation.

## 6.3 Specimens for tensile testing

### 6.3.1 General

Prepare a set of six specimens of the metallic material(s) to be brazed which comply with either [Figure 1](#) or [Figure 2](#). Replace specimens that have visible shrinkages, defects or porosities. Cut the specimens of the set at right angles to its long axis at the midpoint of the gauge length using a fine saw. Remove rough edges. Grind the cut surface smooth, plane and perpendicular to the axis of the test specimen.

### 6.3.2 Procedure

Support the two halves of the specimens and align them in an investment or a rigid jig. If two different metallic materials are to be brazed, use one of each for the two halves. Set the gap between the cut pieces at  $(0,2 \pm 0,1)$  mm. Use the recommended flux and follow the manufacturer's instructions on brazing.

After brazing, ensure that the diameter of each tensile specimen is within the tolerances given in [Figure 1](#) or [Figure 2](#), and does not show visual evidence of radial run-out when rotated.

### 6.3.3 Additional testing

If the proof strength of non-proportional elongation of the dental metallic material for which the brazing material is recommended is less than 250 MPa, prepare an additional set of six specimens of the metallic material to be brazed to determine its 0,2 % of proof strength.

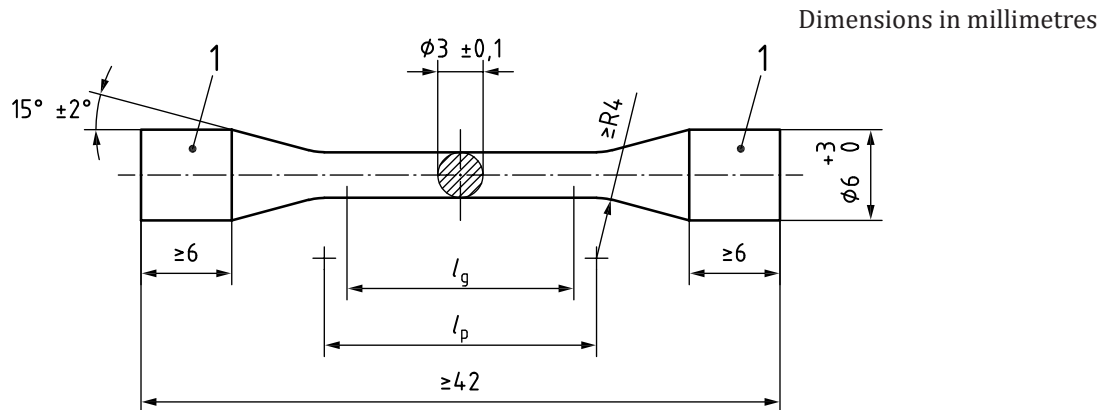

**Key**

- 1 gripped portion
- $l_g$  initial gauge length of  $(15 \pm 0,1)$  mm
- $l_p$  parallel section of  $(18 \pm 0,1)$  mm

**Figure 1 — Specimen with conical shoulders**

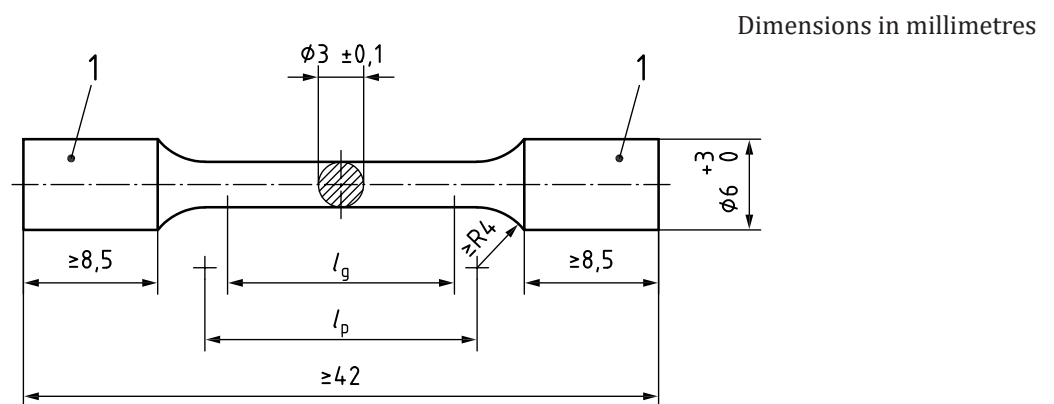

**Key**

- 1 gripped portion
- $l_g$  initial gauge length of  $(15 \pm 0,1)$  mm
- $l_p$  parallel section of  $(18 \pm 0,1)$  mm

**Figure 2 — Specimen with radial shoulders**

## 7 Measurement and test methods

### 7.1 Visual inspection

#### 7.1.1 Specimens

Without the aid of magnification, inspect the surface of specimens to be tested for visible defects. Replace any test specimens that have defects.

#### 7.1.2 Instruction for use, packaging and labelling

Visually inspect the instruction for use, the marking, the labelling and the packaging of the brazing material to check that the requirements specified in [Clauses 8](#) and [9](#) have been met.

### 7.2 Chemical composition

Determine the composition of the brazing material using analytical procedures with sensitivities appropriate to the concentration of each element and its permitted deviation from the stated value or permitted limit.

### 7.3 Tensile testing

#### 7.3.1 Apparatus

**7.3.1.1 Micrometer**, accurate to 0,01 mm with a measuring capacity of 25 mm.

**7.3.1.2 Universal mechanical testing machine.**

Select grips appropriate for the specimens to be used. Conduct tensile testing with a system that has a spring constant (defined as the ratio of the load applied to its elastic deflection) very significantly greater than the load-extension ratio of the specimen under test.

NOTE The system comprises the testing machine frame, load cell and attachments.

Use a universal testing machine that has a capacity in excess of 4 kN for both frame and load cell, and that operates at a cross-head speed up to 2 mm/min. Record the specimen extension-free from the machine deflection.

#### 7.3.2 Test procedure

Determine the tensile strength on a set of six brazed specimens, produced in accordance with [6.3](#).

If applicable, determine the 0,2 % of proof strength of non-proportional elongation for the metallic material intended for brazing. Use a set of six specimens.

Measure the diameter of each specimen to an accuracy of 0,01 mm using the micrometer.

Conduct the test at ambient room temperature.

Load the specimens in tension in the universal mechanical testing machine at a cross-head speed of  $(1,5 \pm 0,5)$  mm/min up to the fracture point of the specimens. Record the force and elongation continuously.

Examine the fractured specimen to determine whether the fracture occurred within the gauge length of the specimen. If the fracture has taken place outside the gauge length, reject the specimen and its result. Replace the specimen and repeat the test.

Calculate the tensile strength of each specimen on the basis of the original cross-sectional area, using the force derived from the force/extension recording.

If appropriate, determine the force at which there is 0,2 % of non-proportional extension, from the force/extension records of the metallic material and calculate the proof strength of non-proportional elongation on the basis of the original cross-sectional area.

### 7.3.3 Evaluation of the tensile test results

#### 7.3.3.1 Pass/fail criteria

If four, five or six specimens exceed the minimum requirement given in [4.3](#), the brazing material satisfies the tensile strength requirement of this document.

If two or fewer specimens comply with the minimum requirement given in [4.3](#), the brazing material fails the tensile strength requirement of this document.

#### 7.3.3.2 Test repetition and pass/fail criteria

If three specimens comply with the minimum requirement given in [4.3](#), repeat the test with a second set of six test specimens.

If in the second test, five or six specimens exceed the minimum requirement given in [4.3](#), the brazing material satisfies the tensile strength requirement of this document.

If in the second test, four or fewer specimens exceed the minimum requirement given in [4.3](#), the brazing material fails the tensile strength requirement of this document.

## 7.4 Corrosion resistance

### 7.4.1 General

Perform the static seven-day immersion test according to ISO 10271:2020, 4.1, with two of the brazed specimens.

### 7.4.2 Analysis

Analyse each test solution quantitatively for constituents of the brazing materials as specified in [Clause 9 c\)](#) and the constituents of the metallic material to be joined, as specified in ISO 22674:2022, 10.1 a). In addition, analyse for nickel, cadmium, beryllium and lead.

### 7.4.3 Microscopic inspection

Perform microscopic inspection of the brazed joints with a magnification of at least  $\times 10$  prior to and after corrosion testing. Record the surface of the brazed joints by appropriate micro-photography.

### 7.4.4 Corrosion test report

A test report for the corrosion test shall be prepared. The following information shall be included in the test report:

- a) description of the analytical method used;
- b) detection limits for the elements under investigation;
- c) a microphotography of the corrosion on the brazed joint;
- d) for all elements found in each test solution, record the values in  $\mu\text{g}/\text{cm}^2$  separately;

- e) calculate the total amount of leached ions for each test solution and report the mean.

## 7.5 Melting range

Determine the melting range of the brazing material by the cooling curve method in accordance with ISO 22674:2022, 8.10, or other methods of equivalent accuracy. By using the cooling curve method, determine the solidus and liquidus temperatures to an accuracy of  $\pm 10$  °C for temperatures below or equal to 1 200 °C or  $\pm 25$  °C for temperatures above 1 200 °C.

Report to the nearest 10 °C.

## 8 Test report

At the conclusion of testing, a test report shall be compiled, presenting the test procedures listed in this document. This report shall include at least the following details:

- a) product name or brand name of brazing material;
- b) name of the manufacturer;
- c) lot number of the brazing material;
- d) information on how specimens were produced, for example, by casting, additive manufacturing, subtractive manufacturing;
- e) used materials and devices;
- f) conducted heat treatments (e.g. simulated ceramic firings, stress relieving);
- g) single values and descriptive statistics (e.g. mean value, min/max value, standard deviation);
- h) determination of compliance with the requirements;
- i) composition: give values with an accuracy of a mass fraction for the elements given in [4.1.2](#) as specified in [4.1.3](#), and with an accuracy of a mass fraction of 0,01 % for the hazardous elements given in [4.1.4](#);
- j) corrosion: value of all released ions in  $\mu\text{g}/\text{cm}^2$  in 7 d;
- k) solidus/liquidus temperatures or melting point in °C;
- l) tensile strength: report the mean value to the nearest 5 MPa;
- m) elongation after fracture: report the mean value to the nearest 1 %;
- n) date of test;
- o) name of test organization;
- p) the International Standard used (including its year of publication);
- q) the method used (if the standard includes several);
- r) any deviations from the procedure;
- s) any unusual features observed.

## 9 Instruction for use

The instruction for use (IFU) for a brazing material shall contain at least the following information:

- a) name and address of manufacturer and authorized representative;

- b) trade name;
- c) all elements present in excess of a mass fraction of 1 % shall be stated quantitatively and all other alloying elements present in concentrations between a mass fraction of 0,1 % and a mass fraction of 1 % shall be mentioned either by name or by symbol;
- d) if the brazing material contains nickel in excess of 0,1 % mass fraction, adequately detailed information regarding its potential for adverse reactions and the text: "This product contains nickel.";
- e) melting range (solidus and liquidus temperature) in degree Celsius;
- f) working temperature in degree Celsius;
- g) recommendation for fluxes;
- h) either metallic materials, or the combinations, recommended for use with the brazing material or both;
- i) detailed instructions for the brazing process;
- j) edition date of the IFU.

## 10 Marking and labelling

### 10.1 Marking

The brazing material or the primary packaging of brazing material shall be clearly marked to identify the manufacturer and the brazing material.

### 10.2 Labelling

The label or the insert in the package shall be marked at least with the following information:

- a) name and address of manufacturer and authorized representative;
- b) trade name;
- c) intended use;
- d) lot number;
- e) minimum net mass, expressed in grams;
- f) all elements in the brazing material, present in excess of a mass fraction of 1 % shall be stated quantitatively and all elements present in concentrations between a mass fraction of 0,1 % and 1 % shall be mentioned either by name or by symbol;
- g) if the brazing contains more than a nickel mass fraction of 0,1 % [see [Clause 9 d\)](#)], a caution symbol in accordance with ISO 15223-1:2021, Table 1 (a triangle within which there is an exclamation mark).
- h) optional: working temperature.

### 10.3 Packaging

The brazing material shall be packed in accordance with accepted commercial practice to prevent any contamination or damage.

## Bibliography

- [1] ISO 7405, *Dentistry — Evaluation of biocompatibility of medical devices used in dentistry*
- [2] ISO 10993-1, *Biological evaluation of medical devices — Part 1: Evaluation and testing within a risk management process*





