**Foot and leg protectors —
Requirements and test methods for
footwear components —**

Part 4:
**Non-metallic perforation resistant
inserts**

*Protecteurs du pied et de la jambe — Exigences et méthodes d'essais
pour les composants de chaussure —*

Partie 4: Inserts anti-perforation non métalliques





COPYRIGHT PROTECTED DOCUMENT

© ISO 2021

All rights reserved. Unless otherwise specified, or required in the context of its implementation, no part of this publication may be reproduced or utilized otherwise in any form or by any means, electronic or mechanical, including photocopying, or posting on the internet or an intranet, without prior written permission. Permission can be requested from either ISO at the address below or ISO's member body in the country of the requester.

ISO copyright office
CP 401 • Ch. de Blandonnet 8
CH-1214 Vernier, Geneva
Phone: +41 22 749 01 11
Email: copyright@iso.org
Website: www.iso.org

Published in Switzerland

Contents

	Page
Foreword.....	iv
Introduction.....	v
1 Scope.....	1
2 Normative references.....	1
3 Terms and definitions.....	1
4 Requirements for non-metallic perforation resistant inserts.....	2
4.1 General.....	2
4.2 Resistance to perforation.....	2
4.3 Flexing resistance.....	3
4.4 Stability against ageing and environmental influence.....	3
4.5 Electrical resistance.....	3
5 Test methods for the non-metallic perforation tests.....	3
5.1 Determination of perforation resistance.....	3
5.1.1 Method PL: with conical nail 4,5 mm diameter.....	3
5.1.2 Method PS: with conical nail 3,0 mm diameter.....	3
5.2 Determination of flexing resistance.....	3
5.2.1 Apparatus.....	3
5.2.2 Sampling.....	4
5.2.3 Test procedure.....	5
5.2.4 Results.....	5
5.2.5 Test report.....	5
5.3 Test methods for the assessment non-metallic perforation resistant inserts in critical environment.....	6
5.3.1 Sampling.....	6
5.3.2 Effect of high temperature.....	6
5.3.3 Effect of acid sweat.....	6
5.3.4 Effect of alkali sweat.....	6
5.3.5 Effect of fuel oil.....	6
5.3.6 Results.....	6
5.3.7 Test report.....	6
5.4 Determination of the electrical resistance.....	7
5.4.1 Testing procedure.....	7
5.4.2 Test report.....	7
6 Marking.....	8
Annex A (normative) Method PL: perforation resistance with the conical nail 4,5 mm diameter.....	9
Annex B (normative) Method PS: Perforation resistance with the conical nail 3,0 mm diameter.....	13
Bibliography.....	18

Foreword

ISO (the International Organization for Standardization) is a worldwide federation of national standards bodies (ISO member bodies). The work of preparing International Standards is normally carried out through ISO technical committees. Each member body interested in a subject for which a technical committee has been established has the right to be represented on that committee. International organizations, governmental and non-governmental, in liaison with ISO, also take part in the work. ISO collaborates closely with the International Electrotechnical Commission (IEC) on all matters of electrotechnical standardization.

The procedures used to develop this document and those intended for its further maintenance are described in the ISO/IEC Directives, Part 1. In particular, the different approval criteria needed for the different types of ISO documents should be noted. This document was drafted in accordance with the editorial rules of the ISO/IEC Directives, Part 2 (see www.iso.org/directives).

Attention is drawn to the possibility that some of the elements of this document may be the subject of patent rights. ISO shall not be held responsible for identifying any or all such patent rights. Details of any patent rights identified during the development of the document will be in the Introduction and/or on the ISO list of patent declarations received (see www.iso.org/patents).

Any trade name used in this document is information given for the convenience of users and does not constitute an endorsement.

For an explanation of the voluntary nature of standards, the meaning of ISO specific terms and expressions related to conformity assessment, as well as information about ISO's adherence to the World Trade Organization (WTO) principles in the Technical Barriers to Trade (TBT), see www.iso.org/iso/foreword.html.

This document was prepared by Technical Committee ISO/TC 94, *Personal safety — Personal protective equipment*, Subcommittee SC 3, *Foot protection*, in collaboration with the European Committee for Standardization (CEN) Technical Committee CEN/TC 161, *Foot and leg protectors*, in accordance with the Agreement on technical cooperation between ISO and CEN (Vienna Agreement).

This second edition cancels and replaces the first edition (ISO 22568-4:2019), which has been technically revised

The main changes are as follows:

- [Table 2](#), changes in the type names from X and Y to PL and PS, new requirements (“tent effect” and minimum value of 950 N);
- new nail, see [Figure B.1](#) (conical shape instead of pyramidal);
- new definition in [3.2](#);
- [Figure B.3](#) new dimension of the nail;
- Annex C and the reference material have been deleted.

A list of all parts in the ISO 22568 series can be found on the ISO website.

Any feedback or questions on this document should be directed to the user's national standards body. A complete listing of these bodies can be found at www.iso.org/members.html.

Introduction

ISO 20345, ISO 20346 and ISO 20347 are related to safety, protective and occupational footwear which define the performance and required properties of the footwear. On introducing these standards all national standards relating to perforation resistant inserts were withdrawn leaving the manufacturers of these items with no means of demonstrating the performance of their products. This document has been prepared to allow manufacturers to demonstrate the type of the perforation resistant inserts before being inserted into the footwear.

Non-metallic perforation resistant inserts and materials complying with the requirements of this document are suitable components of “PPE footwear”.

Foot and leg protectors — Requirements and test methods for footwear components —

Part 4: Non-metallic perforation resistant inserts

1 Scope

This document specifies requirements and test methods for the non-metallic inserts with resistance against mechanical perforation, intended to function as components of PPE footwear (e.g. as described by ISO 20345, ISO 20346 and ISO 20347).

2 Normative references

The following documents are referred to in the text in such a way that some or all of their content constitutes requirements of this document. For dated references, only the edition cited applies. For undated references, the latest edition of the referenced document (including any amendments) applies.

ISO 105-E04:2013, *Textiles — Tests for colour fastness — Part E04: Colour fastness to perspiration*

ISO 20344, *Personal protective equipment — Test methods for footwear*

ISO 20345, *Personal protective equipment — Safety footwear*

ISO 20346, *Personal protective equipment — Protective footwear*

ISO 20347, *Personal protective equipment — Occupational footwear*

3 Terms and definitions

For the purposes of this document, the terms and definitions given in ISO 20345, ISO 20346 and ISO 20347 and the following apply.

ISO and IEC maintain terminological databases for use in standardization at the following addresses:

- ISO Online browsing platform: available at <https://www.iso.org/obp>
- IEC Electropedia: available at <https://www.electropedia.org/>

3.1

non-metallic perforation resistant insert

non-metallic footwear component placed (or intended to be placed) in the sole complex or used as an insole simultaneously in order to provide protection against perforation

3.2

“tent effect”

separation between the layers of the test piece during the testing procedure, some layers are perforated other not giving, the aspect of the tent to the test piece

Note 1 to entry: The procedure is given in [Annex A](#).

4 Requirements for non-metallic perforation resistant inserts

4.1 General

Depending on the footwear construction, the non-metallic perforation resistant inserts could be in contact with the wearer foot, therefore the requirements of ISO 20345, ISO 20346 and ISO 20347 should be taken into account (for example abrasion resistance, water absorption, innocuousness).

Perforation resistant material can be tested in accordance with this document, even in an unshaped status, if it is intended to be cut and/or shaped by the footwear or sole manufacturer. When shaped non-metallic perforation resistant inserts are tested in accordance with this document, their suitability to fit into footwear is not assured, because the dimensional conformity to the footwear depends on the individual shape of each model of footwear.

Table 1 — Summary of requirements and number of samples

Property	Subclause	Number of samples	Status
Resistance to perforation	4.2	Non-metallic material: 1 sample or Ready –shaped inserts: 1 sample	mandatory
Flexing resistance	4.3	Non-metallic material: 1 sample or Ready – shaped inserts: 2 different sizes	mandatory
Stability against ageing and environmental influence	4.4	Non-metallic material: 2 samples for each treatment or Ready –shaped inserts: 2 samples for each treatment	mandatory
Electrical resistance	4.5	Non-metallic material: 1 sample	optional
NOTE For details, see 4.2 to 4.5 .			

For each of the required measurements performed in accordance with this standard, a corresponding estimate of the uncertainty of measurement should be evaluated. One of the following approaches shall be used:

- a statistical method, e.g. that given in ISO 5725-2^[2];
- a mathematical method, e.g. that given in ISO/IEC Guide 98-3^[4];
- uncertainty and conformity assessment as given in ISO/IEC Guide 98-4^[5];
- JCGM 100^[6].

4.2 Resistance to perforation

When the non-metallic perforation resistant inserts are tested in accordance with the applicable methods described in [5.1](#), they shall meet one of the two types given in [Table 2](#).

Table 2 — Minimum requirements for the perforation force

Types	Test method	Requirements
Type PL	See 5.1.1	Perforation test (see A.4); the four results reported shall be “pass” with a force of 1100 N No “tent effect” shall occur
Type PS	See 5.1.2	Perforation force (B.4) the average value reported shall be greater or equal to 1100 N No single value shall be lower than 950 N
NOTE This property has two types in term of the protection afforded. This covers the degree of risk or hazard that a user will face in terms of the type of working places. Type PS offers more appropriate protection from smaller diameter and sharper objects than type PL.		

4.3 Flexing resistance

When tested in accordance with the method described in [5.2](#), the non-metallic perforation resistant insert shall exhibit no visible signs of cracking, disintegration or delamination after having been subjected to 1×10^6 (one million) flexion cycles.

4.4 Stability against ageing and environmental influence

When subjected to each single one of the 4 treatments described in [5.3](#) and tested in accordance with the method described in [5.1](#), the non-metallic perforation resistant insert shall conform to the requirements of [4.2](#).

4.5 Electrical resistance

This property is optional and frequently requested when the non-metallic perforation resistant inserts are supposed to be used in a footwear with electrical properties (ISO 20345:2021, 6.2.2.1 and 6.2.2.2).

The results of this test, see [5.4](#), is given as an information, this document does not fix requirements.

5 Test methods for the non-metallic perforation tests

5.1 Determination of perforation resistance

5.1.1 Method PL: with conical nail 4,5 mm diameter

The test method described in [Annex A](#) shall be used.

5.1.2 Method PS: with conical nail 3,0 mm diameter

The test method described in [Annex B](#) shall be used.

5.2 Determination of flexing resistance

5.2.1 Apparatus

Flexing apparatus, comprising a suitable flexing guide (e.g. a pair of bars) to move the free end of the non-metallic perforation resistant insert through a specified distance at a defined rate and a clamping device consisting of two elastic interlayers approximately 4 mm thick and of Shore A hardness 75 ± 5 with two metal clamping plates at least 130 mm wide.

In the zero position, the guide acts at a distance of (70 ± 1) mm from the clamping plates (see [Figure 1](#)).

Dimensions in millimetres

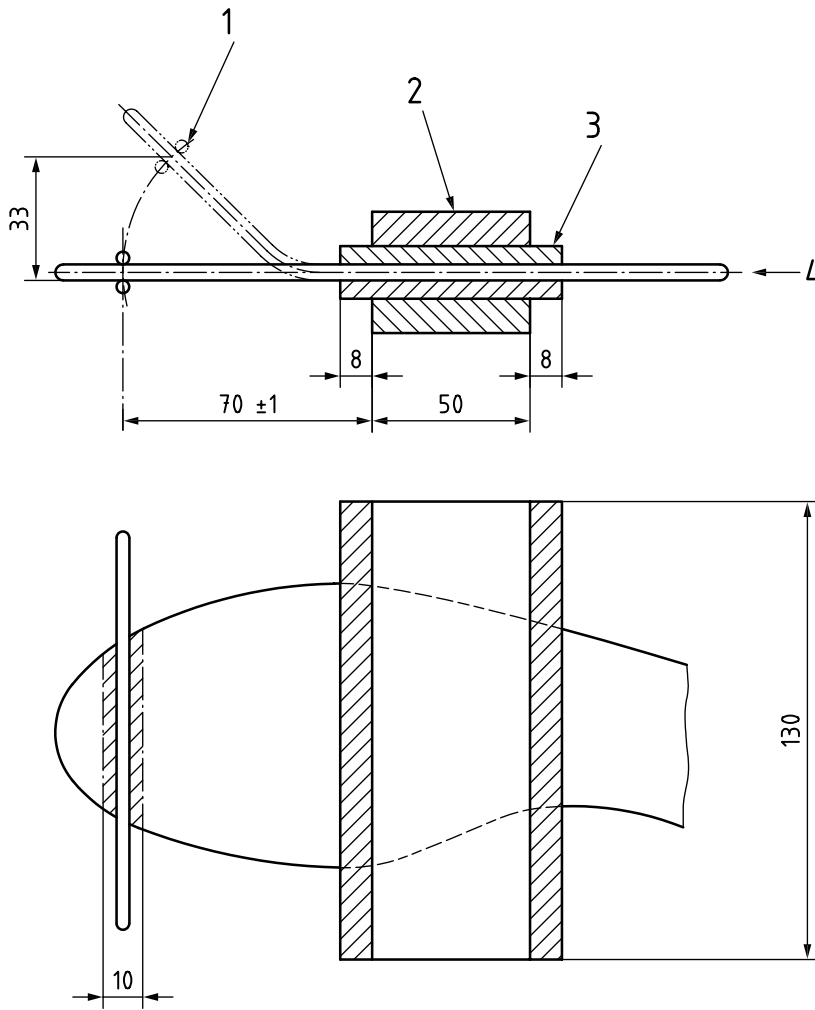

Key

- | | |
|-------------------|----------------------|
| 1 flexing guide | 3 elastic interlayer |
| 2 clamping plates | 4 test piece |

Figure 1 — Example of details of a suitable construction of a flexing apparatus for non-metallic perforation resistant inserts

5.2.2 Sampling

5.2.2.1 Number of test pieces

In case of ready-shaped non-metallic perforation resistant inserts, samples of two different sizes shall be tested. For unshaped material cut out two suitable test pieces, giving them a shape similar to a typical insole of approximate size 41 to 42 (Paris Point).

5.2.2.2 Determination of the flexing line

Lay the non-metallic perforation resistant insert with its inner edge against a straight base line in such a way that this line is at a tangent to the insert in the joint and heel regions. At the tangent to the joint construct a perpendicular. This line is the flexing line at which the insert is clamped (see [Figure 2](#)).

Dimensions in millimetres

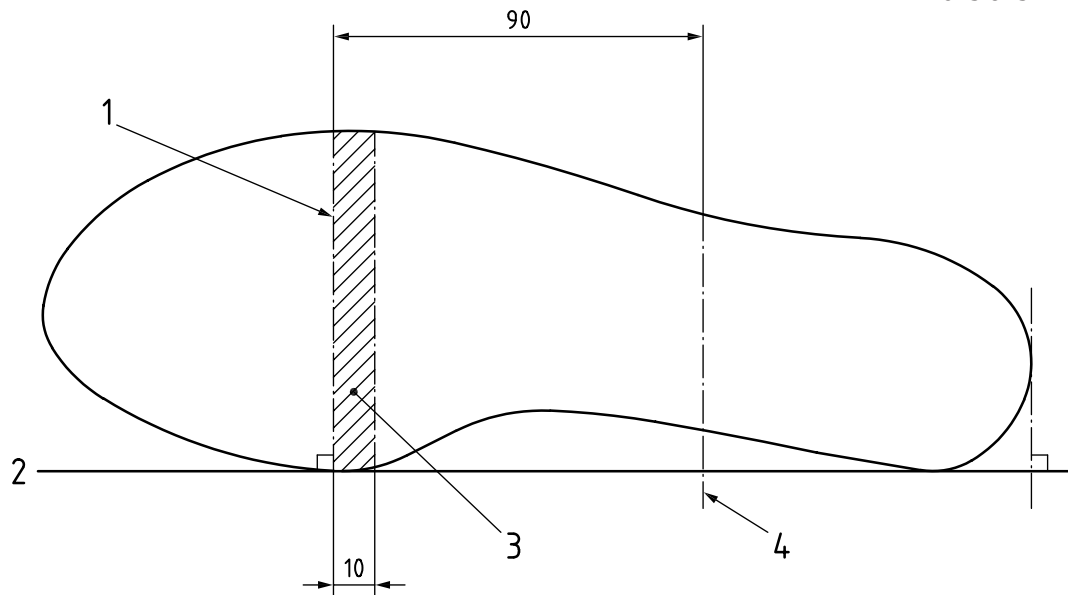
**Key**

- | | | | |
|---|--------------|---|--------------|
| 1 | flexing line | 3 | flexing zone |
| 2 | base line | 4 | line of cut |

Figure 2 — Flexing line for non-metallic perforation resistant inserts

5.2.2.3 Preparation of test piece

If necessary, cut off the heel part of the non-metallic perforation resistant insert at a distance of at least 90 mm from the flexing line (see [Figure 2](#) and [5.2.2.2](#)).

5.2.3 Test procedure

Deflect the test piece at a rate of (16 ± 1) Hz by moving the guide bar to a height of 33 mm, measured vertically above the zero position. Ensure by means of a guide that the test piece returns to the zero position after every deflection. After 1×10^6 flexes, carry out a visual examination of the test piece.

5.2.4 Results

For ready-shaped non-metallic perforation resistant inserts, the two results for the two different sizes shall be reported.

In case of unshaped material, the 2 results shall be reported.

5.2.5 Test report

The test report shall include the following information:

- a reference to this document, i.e. ISO 22568-4:2021;
- a full description of the samples tested including sizes, commercial styles, codes, colours, nature, etc.;
- the results of the visual examination;
- description of any change of the test piece (for example delamination);
- any deviation by agreement and otherwise from the present test method.

5.3 Test methods for the assessment non-metallic perforation resistant inserts in critical environment

5.3.1 Sampling

In case of ready-shaped non-metallic perforation resistant inserts, samples of two different sizes shall be tested. For unshaped material cut out two suitable test pieces, giving them a shape similar to a typical insole of approximate size 41 to 42 (Paris Point).

New samples shall be used for each of the following 4 treatments.

5.3.2 Effect of high temperature

Clamp the specimen into the perforation device and place them in an oven with forced air circulation, which is maintained at (60 ± 2) °C for $4 \text{ h} \pm 10 \text{ min}$; reduce the temperature to (45 ± 2) °C for another 18 h to 20 h. Remove the assembly from the oven and, within $2 \text{ min} \pm 30 \text{ s}$ from removing it from the oven (or from an insulating box which may be used if necessary), start performing the perforation test in accordance with the method described in [5.1](#).

5.3.3 Effect of acid sweat

The non-metallic perforation resistant insert shall be totally immersed in an acid sweat solution, as specified in ISO 105-E04:2013, 4.4, at (23 ± 2) °C for $24 \text{ h} \pm 15 \text{ min}$. Remove, wash off any excess sweat with water and store at (23 ± 2) °C for (24 ± 1) h before testing it in accordance with the method described in [5.1](#).

5.3.4 Effect of alkali sweat

The non-metallic perforation resistant insert shall be totally immersed in an alkali sweat solution, as specified in ISO 105-E04:2013, 4.3, at (23 ± 2) °C for $24 \text{ h} \pm 15 \text{ min}$. Remove, wash off any excess sweat with water and store at (23 ± 2) °C for (24 ± 1) h before testing it in accordance with the method described in [5.1](#).

5.3.5 Effect of fuel oil

Totally immerse the perforation resistant insert in 2,2,4-trimethylpentane (iso-octane) at (23 ± 2) °C for $24 \text{ h} \pm 15 \text{ min}$. Remove, dry off any excess liquid and store at (23 ± 2) °C for (24 ± 1) h before testing it in accordance with the method described in [5.1](#).

5.3.6 Results

For ready-shaped non-metallic perforation resistant inserts, the two results for the 2 different sizes of the 4 treatments shall be reported.

In case of unshaped material, the two results of the four treatments shall be reported.

5.3.7 Test report

The test report shall include the following information:

- a) a reference to this document, i.e. ISO 22568-4:2021;
- b) a full description of the samples tested including commercial sizes, styles codes, colours, nature, etc.;
- c) the results obtained after the four treatments;
- d) description of any change of the test piece (for example delamination, cracking, disintegration);

- e) sampling procedure;
- f) any deviation by agreement and otherwise from the present test method;
- g) date of testing.

5.4 Determination of the electrical resistance

5.4.1 Testing procedure

Place the non-metallic perforation resistant insert in an oven with forced air circulation, which is maintained at $(60 \pm 2) ^\circ\text{C}$ for at least 24 h. The test shall be done within the next 5 min.

Non-metallic perforation resistant inserts shall be tested in accordance with the method described in ISO 20344:2021, 5.13.4, with the following variations:

- Test-piece of dimensions $(230 \pm 5) \text{ mm} \times (80 \pm 5) \text{ mm}$;
- Frame of internal dimensions (length $200 \pm 5 \text{ mm}$, width $50 \pm 2 \text{ mm}$ and height minimum 100 mm) to hold 4 kg of steel balls. The frame is constituted with insulating material (for example wood), see [Figure 3](#).

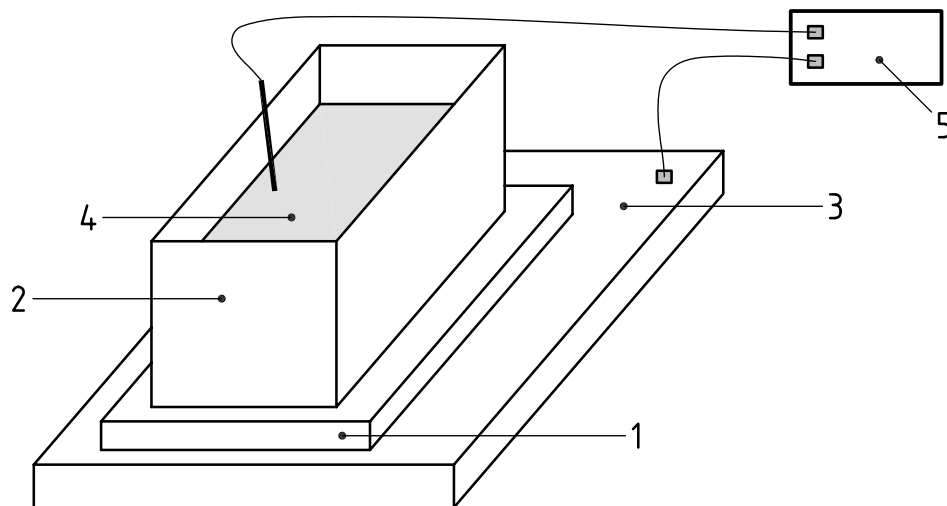

Key

- 1 test-piece of dimensions $(230 \pm 5) \text{ mm} \times (80 \pm 5) \text{ mm}$
- 2 frame of internal dimensions (length $200 \pm 5 \text{ mm}$, width $50 \pm 2 \text{ mm}$ and height minimum 100 mm)
- 3 copper electrode
- 4 frame containing steel balls (4 kg)
- 5 apparatus measuring the electrical resistance

Figure 3 — Example of a suitable setting for the determination of the electrical resistance of non-metallic perforation resistant inserts

5.4.2 Test report

The test report shall include the following information:

- a) a reference to this document, i.e. ISO 22568-4:2021;
- b) a full description of the samples tested including sizes, commercial styles, codes, colours, nature, etc.;

- c) the results obtained in [5.4.1](#);
- d) description of any change of the test piece;
- e) any deviation by agreement and otherwise from the present test method;
- f) date of testing.

6 Marking

Non-metallic perforation resistant inserts shall be clearly and permanently marked with the following information:

- a) non-metallic perforation resistant insert size (if applicable);
- b) manufacturer's identification mark;
- c) manufacturer's type designation;
- d) the type of performance claimed for perforation force (Type PL or Type PS);
- e) number of this document and year of publication.

NOTE Marking by embossing is acceptable. Marking of the size is not compulsory when the material is distributed as platen and die-cutting or otherwise shaping is performed by a third party.

Annex A (normative)

Method PL: perforation resistance with the conical nail 4,5 mm diameter

A.1 Apparatus

A.1.1 Compression machine, capable of applying a uniform speed of (10 ± 3) mm/min and of measuring compressive forces up to at least 2 kN.

A.1.2 Test nail, as shown in [Figure A.1](#), of diameter $(4,5 \pm 0,05)$ mm with a truncated end of the form and dimensions:

- hardenable steel;
- hardness HRC ≥ 60 has proven to be suitable for the nail;
- shape conical, angle $(30 \pm 2)^\circ$;
- diameter $(4,5 \pm 0,05)$ mm;
- with a truncated end $(1 \pm 0,02)$ mm diameter;
- length ≥ 80 mm.

The test nail should be examined after 125 perforations for its ongoing conformity to [Figure A.1](#), in case of non-conformity the test nail shall be corrected or replaced.

A.1.3 Clamping device: A suitable clamping device consists of two rigid metallic plates with central coaxial holes of diameter $(25 \pm 0,2)$ mm, connected by screws or other suitable means to clamp the test piece in position and prevent it from slipping during the perforation test (see [Figure A.2](#)). This device is fixed to the upper traverse of the compression test machine in a way that the test piece can be visually inspected on its upper surface opposite to the perforation. To enable visual inspection, the thickness of the upper platen shall not be more than 5 mm, with a conical shape around the centre hole as specified in [Figure A.2](#). The test nail is fixed upwards to the lower sample holder of the compression test machine so that the tip of the nail will be forced perpendicularly against the centre of the test piece (or vice versa) when the machine runs.

NOTE To prevent slipping, a special preparation of the clamping surfaces (e.g. application of emery paper) can be appropriate. Also, the use of a tensile testing machine is possible if mounting the clamping device into a compression cage.

A.2 Preparation of test piece

The sample shall be conditioned at least 24 h at (23 ± 2) °C and (50 ± 5) % relative humidity before testing.

In case of ready-shaped non-metallic perforation resistant inserts, one insert is tested. In case of unshaped material cut out a suitable test piece, giving it a shape similar to a typical insole of approximate size 41 to 42 (Paris Point).

The non-metallic perforation resistant inserts are always included in the footwear in the same way. Therefore, during the perforation test, the face in contact with the foot shall be opposite to the nail.

Dimensions in millimetres

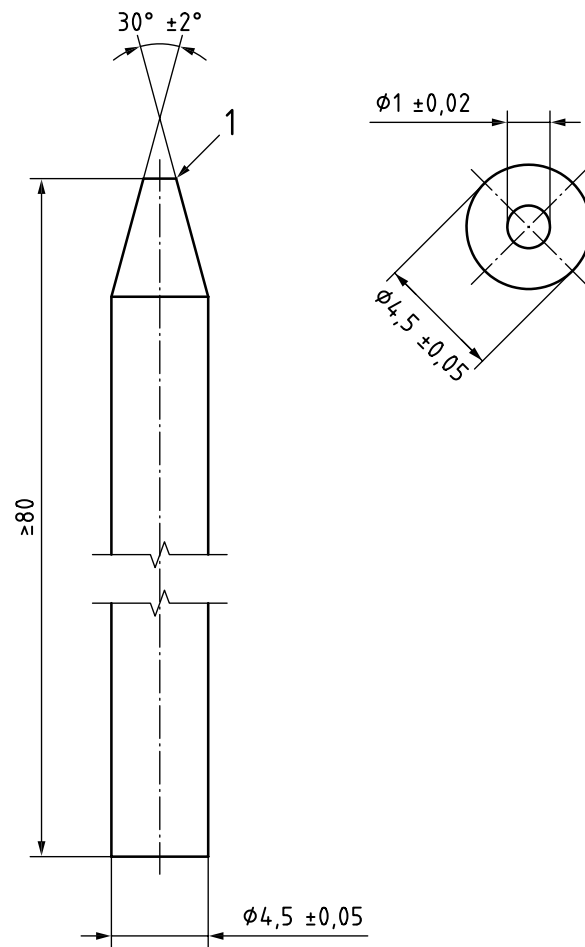

Key

1 truncated tip

Figure A.1 — Test nail for perforation resistance (PL)

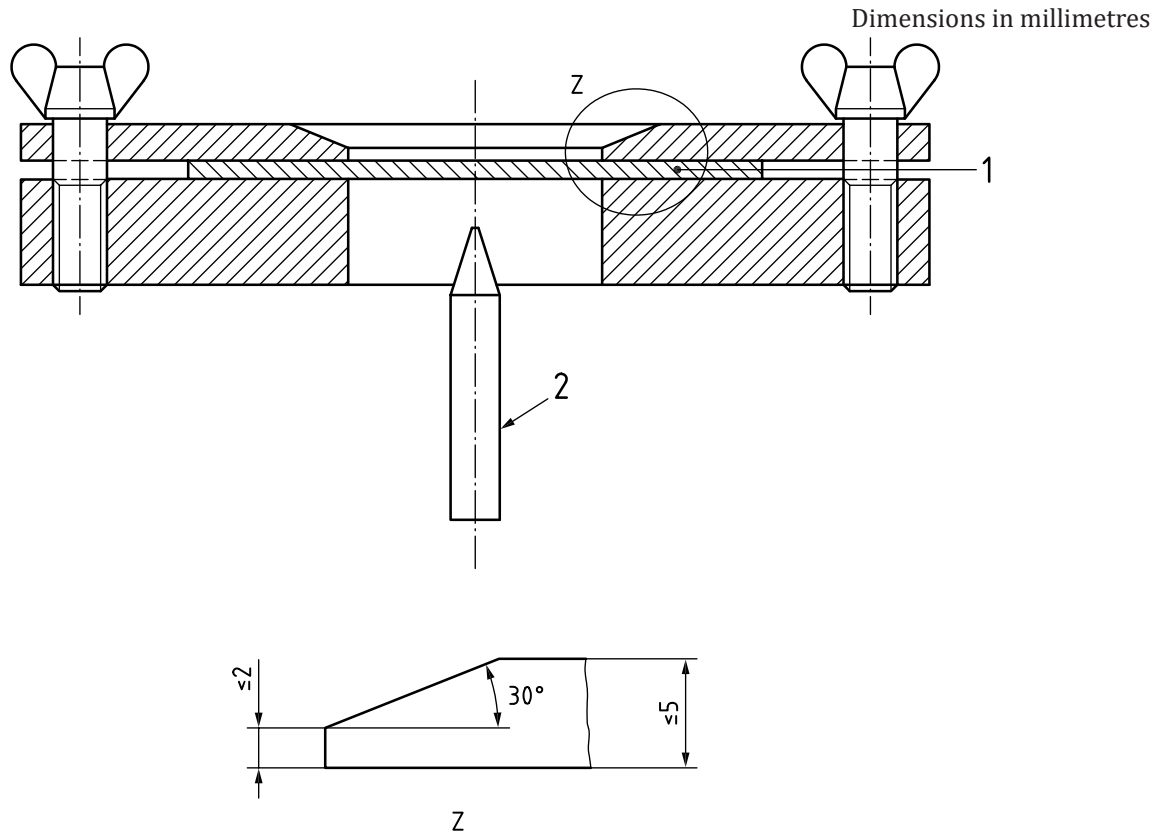
**Key**

- 1 test piece
- 2 nail

Figure A.2 — Schematic example of apparatus for the perforation test of inserts (method PL)

A.3 Procedure

Fix the test piece between the two platens (see [Figure A.2](#)), applying sufficient clamping force to prevent the test piece from slipping. The distance of the point to undergo perforation from any previous perforation point and from any edge of the test piece shall be at least 35 mm.

Run the testing machine at a speed of (10 ± 3) mm/min up to the required force of 1 100 N (see [A.1.1](#)), then stop the machine and carry out either the visual inspection within 10 s at an angle of $(90 \pm 15)^\circ$ to the nail axis or an electrical or cinematographic detection. If the opposite surface of the test piece has been perforated, the test piece has failed the test. Register if separation between the layers of the test piece (“tent effect”) occurs.

NOTE The present method and its requirement lead to a pass/fail result without distinction between different levels of performance. However, in order to obtain additional information, a higher perforation force can be applied, e.g. for research needs or to compare various materials or solutions.

A.4 Results

For ready-shaped non-metallic perforation resistant inserts, one insert shall be tested four times, all results (see [A.3](#)) shall be reported.

In case of unshaped material, the four results shall be reported.

When the inserts are tested in accordance with the applicable method described using a force of at least 1 100 N, the tip of the test nail shall not perforate through the test piece. A “pass” result requires that the tip of the test nail does not protrude from the rear side of the test piece to be checked by visual, cinematographic or electrical detection

If the test piece is subject to “tent effect”, it shall be reported as a failed.

A.5 Test report

The test report shall include the following information:

- a) a reference to this document, i.e. ISO 22568-4:2021;
- b) full description of the samples tested including sizes, commercial styles, codes, colours, nature, etc.;
- c) the results as described in [A.4](#);
- d) description of any change of the test piece (for example delamination);
- e) any deviation by agreement and otherwise from the present test method.

Annex B (normative)

Method PS: Perforation resistance with the conical nail 3,0 mm diameter

B.1 Apparatus

B.1.1 Compression machine, capable of applying a uniform speed of (10 ± 3) mm/min and of measuring compressive forces up to at least 2 kN.

B.1.2 Test nail, as shown in [Figure B.1](#)¹⁾:

- hardenable steel;
- hardness HRC ≥ 60 has proven to be suitable for the nail;
- shape conical, angle $(30 \pm 2)^\circ$;
- diameter $(3,0 \pm 0,03)$ mm;
- with a truncated end $(1 \pm 0,02)$ mm diameter;
- length ≥ 80 mm;
- protruding length approximately (50 ± 5) mm;
- maximum roughness at the tip $Ra < 0,8 \mu\text{m}$.

With certain non-metallic insert, it is possible that the nail may bend during the test, in which case the nail shall be replaced immediately.

The test nail should be examined after 125 perforations for its ongoing conformity to [Figure B.1](#), in case of non-conformity the test nail shall be corrected or replaced.

B.1.3 Clamping device.

A suitable clamping device consists of two rigid metallic plates with central coaxial holes of diameter $(25 \pm 0,2)$ mm, connected by four screws or other suitable means to clamp the test piece in position and prevent it from slipping during the perforation test (see [Figure B.3](#)). This device is fixed to the upper traverse of the compression test machine. The test nail is fixed upwards to the lower sample holder of the compression test machine so that the tip of the nail will be forced perpendicularly against the centre of the test piece (or vice versa) when the machine runs. The nail shall protrude from the mandrel of approximately 50 mm.

NOTE To prevent slipping, a special preparation of the clamping surfaces (e.g. application of emery paper) can be appropriate. Also, the use of a tensile testing machine is possible if mounting the clamping device into a compression cage.

1) Suppliers of a suitable nail are: (1) EST USINAGE S.a.r.L., Technopôle Forbach Sud, 182 rue Lavoisier, F-57600 FORBACH, Tél. +33 (0)3 87 82 31 77, www.est-usinage.com/fr; (2) SITEC S.r.l., Sistemi tecnici e metrologici, Zona Artigianale - Lotti C9/C10, 70056 Molfetta (BA), Tel: 0803385842, www.sitecquality.it. This information is given for the convenience of users and does not constitute an endorsement by ISO. Equivalent products can be used if they can be shown to lead to the same results.

B.1.4 Position of the nail.

The nail shall be aligned with the axis of the clamping device, so that it will perforate at the centre of the 25 mm tested area.

Dimensions in millimetres

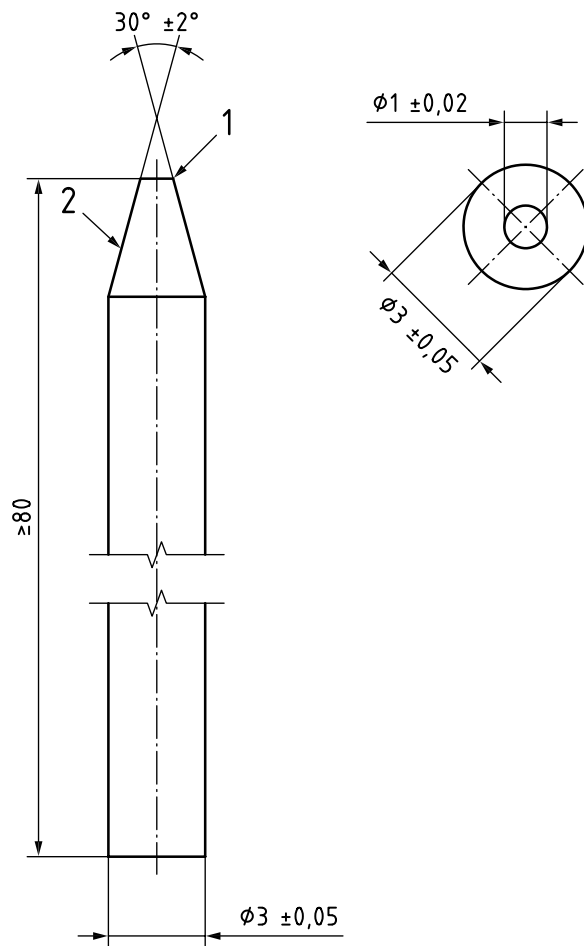

Key

- 1 truncated tip
- 2 truncated conical is with maximum roughness $Ra < 0,8 \mu\text{m}$

Figure B.1 — Test nail for perforation resistance test (method PS)

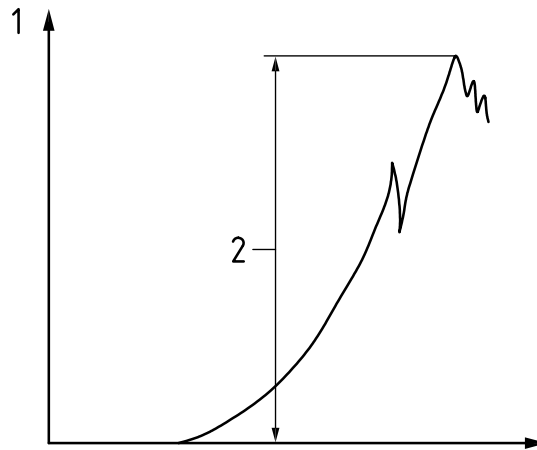
**Key**

- 1 force, in N
- 2 maximum force

Figure B.2 — Maximum force

Dimensions in millimetres

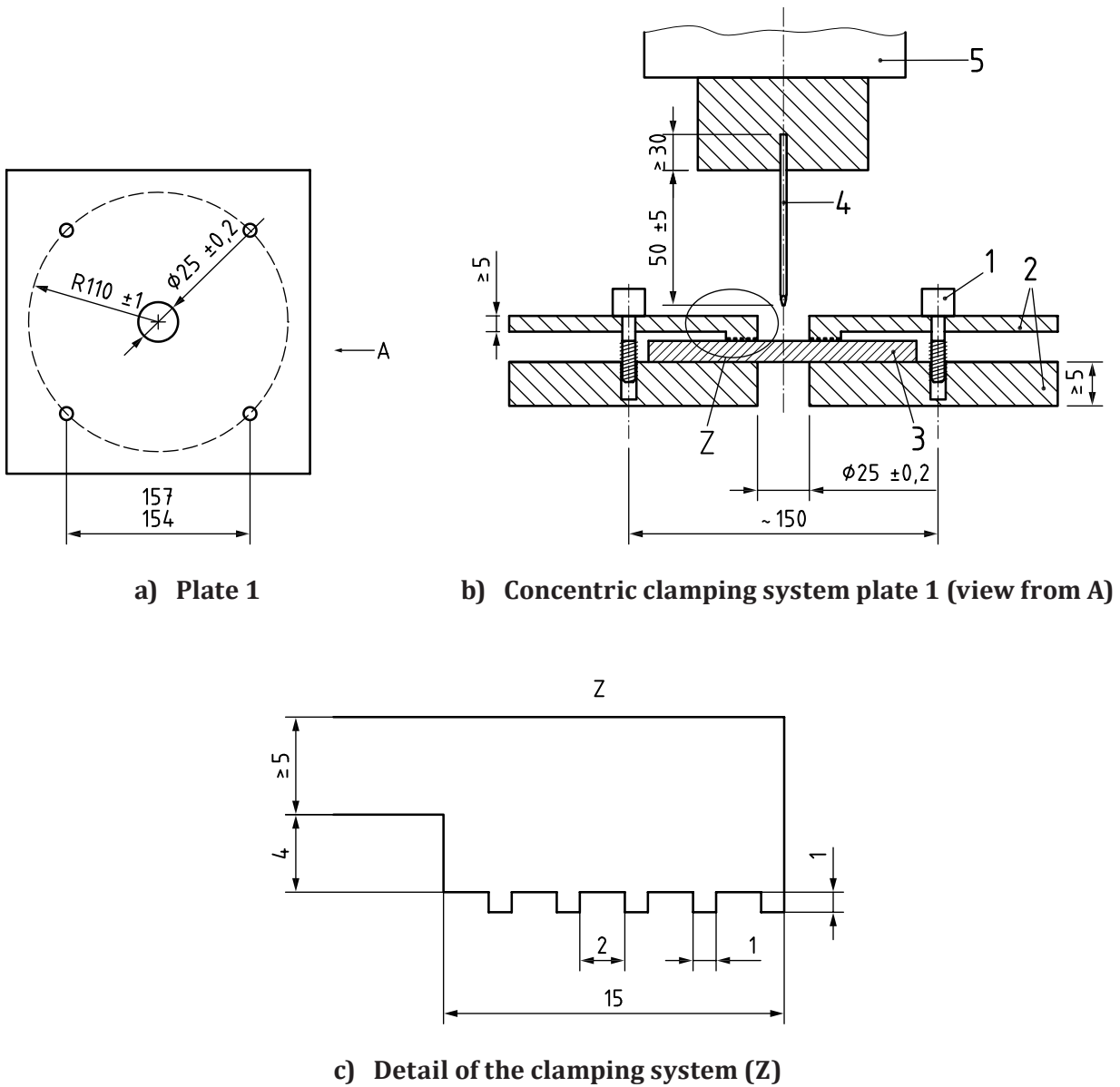

Key

- 1 screw [torque (4 ± 0,4) Nm]
- 2 plate
- 3 test piece
- 4 nail
- 5 pressure platen

Figure B.3 — Schematic example of clamping system for the perforation test (method PS)

B.2 Preparation of test piece

The sample shall be conditioned at least 24 h at (23 ± 2) °C and (50 ± 5) % Relative humidity before testing.

In case of ready-shaped non-metallic perforation resistant inserts, one insert is tested. In case of unshaped material cut out a suitable test piece, giving it a shape similar to a typical insole of approximate size 41 to 42 (Paris Point).

The non-metallic perforation resistant inserts are always included in the footwear in the same way. Therefore, during the perforation test, the face in contact with the foot shall be opposite to the nail.

B.3 Procedure

Fix the test piece firmly between the two platens (see [Figure B.3](#)), good clamping of the sample is important, the sample shall not move during the test.

The four clamping screws (M8 thread) shall be initially tightened by hand, simultaneously tighten diagonally opposing screws in order to maintain the two plates parallel. Then applying a torque of $(4 \pm 0,4)$ Nm on each screw.

The distance of the point to undergo perforation from any previous perforation point and from any edge of the test piece shall be at least 30 mm.

Run the testing machine at a speed of (10 ± 3) mm/min up to and register the maximum force (see [Figure B.2](#)).

Five measurements shall be done and registered. The minimum distance between two points of measurement is 30 mm.

Calculate the average value of the five measurements in Newtons.

B.4 Results

Each single value shall be reported.

The average value (see [B.3](#)) is also reported.

B.5 Test report

The test report shall include the following information:

- a) a reference to this document, i.e. ISO 22568-4:2021;
- b) a full description of the samples tested including sizes, commercial styles, codes, colours, nature, etc.;
- c) the results as described in [B.4](#);
- d) description of any change of the test piece (for example delamination);
- e) any deviation by agreement and otherwise from the present test method.

Bibliography

- [1] ISO 2062, *Textiles — Yarns from packages — Determination of single-end breaking force and elongation at break using constant rate of extension (CRE) tester*
- [2] ISO 5725-2, *Accuracy (trueness and precision) of measurement methods and results — Part 2: Basic method for the determination of repeatability and reproducibility of a standard measurement method*
- [3] ISO 13528, *Statistical methods for use in proficiency testing by interlaboratory comparison*
- [4] ISO/IEC Guide 98-3, *Uncertainty of measurement — Part 3: Guide to the expression of uncertainty in the measurement (GUM 1995)*
- [5] ISO/IEC Guide 98-4, *Uncertainty of measurement — Part 4: Role of measurement uncertainty in the conformity assessment*
- [6] JCGM 100, *Evaluation of measurement data — Guide to the expression of uncertainty in measurement (published by the Bureau International des Poids et Mesures — BIPM)*
- [7] Regulation (EU) 2016/425 of the European Parliament and of the Council of 9 March 2016 on personal protective equipment and repealing Council Directive 89/686/EEC
- [8] EN 13832-2, *Footwear protecting against chemicals — Part 2: Requirements for footwear resistant to chemicals under laboratory conditions*
- [9] EN 13832-3, *Footwear protecting against chemicals — Part 3: Requirements for footwear highly resistant to chemicals under laboratory conditions*
- [10] EN 15090, *Footwear for firefighters*
- [11] EN 50321, *Electrically insulating footwear for working on low voltage installations*

