**Footwear — Critical substances
potentially present in footwear and
footwear components —**

Part 2:
**Determination of phthalate without
solvent extraction**

*Chaussures — Substances critiques potentiellement présentes dans les
chaussures et les composants des chaussures —*

Partie 2: Détermination des phtalates sans extraction par solvant





COPYRIGHT PROTECTED DOCUMENT

© ISO 2021

All rights reserved. Unless otherwise specified, or required in the context of its implementation, no part of this publication may be reproduced or utilized otherwise in any form or by any means, electronic or mechanical, including photocopying, or posting on the internet or an intranet, without prior written permission. Permission can be requested from either ISO at the address below or ISO's member body in the country of the requester.

ISO copyright office
CP 401 • Ch. de Blandonnet 8
CH-1214 Vernier, Geneva
Phone: +41 22 749 01 11
Email: copyright@iso.org
Website: www.iso.org

Published in Switzerland

Contents

	Page
Foreword	iv
1 Scope	1
2 Normative references	1
3 Terms and definitions	1
4 Principle	1
5 Apparatus	2
6 Reagents and materials	2
7 Sampling	3
8 Test procedure	3
8.1 Test sample preparation	3
8.2 Calibration	3
8.3 Chromatographic analysis	4
8.3.1 The chromatography parameters for gas chromatograph – mass spectrometer equipped with a pyrolyzer	4
8.3.2 Qualitative and quantitative analysis by gas chromatograph – mass spectrometer equipped with a pyrolyzer	4
9 Calculation of phthalate compounds in the sample	4
9.1 Calculation of the phthalate compounds in the sample	4
9.2 Performance of the test method	5
10 Detection limit	5
11 Test report	5
Annex A (informative) List of phthalates specified in CEN/TR 16417	6
Annex B (informative) Sampling guidelines	9
Annex C (informative) Chromatography parameters for gas chromatography mass spectrometry equipped with a pyrolyzer	12
Annex D (informative) Verification of the evolved gas analysis (EGA) thermal desorption zone	14
Annex E (informative) Examples of chromatogram for phthalate by Py/TD-GC-MS	16
Annex F (informative) Comparative test results of ISO 16181-1 and this document (i.e. ISO 16181-2)	18
Bibliography	22

Foreword

ISO (the International Organization for Standardization) is a worldwide federation of national standards bodies (ISO member bodies). The work of preparing International Standards is normally carried out through ISO technical committees. Each member body interested in a subject for which a technical committee has been established has the right to be represented on that committee. International organizations, governmental and non-governmental, in liaison with ISO, also take part in the work. ISO collaborates closely with the International Electrotechnical Commission (IEC) on all matters of electrotechnical standardization.

The procedures used to develop this document and those intended for its further maintenance are described in the ISO/IEC Directives, Part 1. In particular, the different approval criteria needed for the different types of ISO documents should be noted. This document was drafted in accordance with the editorial rules of the ISO/IEC Directives, Part 2 (see www.iso.org/directives).

Attention is drawn to the possibility that some of the elements of this document may be the subject of patent rights. ISO shall not be held responsible for identifying any or all such patent rights. Details of any patent rights identified during the development of the document will be in the Introduction and/or on the ISO list of patent declarations received (see www.iso.org/patents).

Any trade name used in this document is information given for the convenience of users and does not constitute an endorsement.

For an explanation of the voluntary nature of standards, the meaning of ISO specific terms and expressions related to conformity assessment, as well as information about ISO's adherence to the World Trade Organization (WTO) principles in the Technical Barriers to Trade (TBT), see www.iso.org/iso/foreword.html.

This document was prepared by Technical Committee ISO/TC 216, *Footwear*, in collaboration with the European Committee for Standardization (CEN) Technical Committee CEN/TC 309, *Footwear*, in accordance with the Agreement on technical cooperation between ISO and CEN (Vienna Agreement).

This first edition of ISO 16181-2, together with ISO 16181-1, cancels and replaces ISO/TS 16181:2011, which has been technically revised.

The main changes compared to the previous edition are as follows:

- phthalates were added to the list in [Table A.1](#) (from 7 onwards);
- this document introduces a new technique.

Any feedback or questions on this document should be directed to the user's national standards body. A complete listing of these bodies can be found at www.iso.org/members.html.

Footwear — Critical substances potentially present in footwear and footwear components —

Part 2:

Determination of phthalate without solvent extraction

WARNING — The use of this document can involve hazardous materials, operations and equipment. It does not purport to address all of the safety or environmental problems associated with its use. It is the responsibility of users of this document to take appropriate measures to ensure the safety and health of personnel and the environment prior to application of the document, and to determine the applicability of regulatory limitations for this purpose.

1 Scope

This document specifies a method for the determination of the content of specific phthalates (see [Annex A](#)) by pyrolyzer/thermal desorption gas chromatography-mass spectrometry (Py/TD-GC-MS). This document is applicable to all types of footwear materials except textiles.

NOTE See also CEN/TR 16417 for a list of the specific phthalates to which this document applies.

2 Normative references

The following documents are referred to in the text in such a way that some or all of their content constitutes requirements of this document. For dated references, only the edition cited applies. For undated references, the latest edition of the referenced document (including any amendments) applies.

ISO 16181-1, *Footwear — Critical substances potentially present in footwear and footwear components — Part 1: Determination of phthalate with solvent extraction*

3 Terms and definitions

No terms and definitions are listed in this document.

ISO and IEC maintain terminological databases for use in standardization at the following addresses:

- ISO Online browsing platform: available at <https://www.iso.org/obp>
- IEC Electropedia: available at <http://www.electropedia.org/>

4 Principle

The sample is directly introduced into a pyrolyzer, the phthalates are thermally extracted under a specific heat zone and then transferred to the gas chromatograph. Phthalate compounds are separated by the gas chromatographic capillary column and detected by a mass spectrometer.

When compared to ISO 16181-1, the two analytical methods should present similar trends but at the same time, not necessarily the same absolute result. Therefore, in case of any dispute, ISO 16181-1 shall be used in preference.

5 Apparatus

5.1 **Analytical balance**, capable of measuring accurately to 0,000 01 g (0,01 mg).

5.2 **Cryogenic grinding/milling mill with liquid N₂ cooling**.

5.3 **Nipper (a hand tool for cutting samples)**.

5.4 **Micro spatula**.

5.5 **Tweezers**.

5.6 **Cutter**.

5.7 **File**.

5.8 **Micro puncher**.

5.9 **Deactivated glass wool**.

5.10 **Micro syringes or automated pipettes**.

5.11 **Sample cup**.

5.12 **Volumetric flasks**, 10 ml and 100 ml.

5.13 **Gas chromatograph – mass spectrometer equipped with a pyrolyzer**.

— Pyrolyzer/thermal desorption accessory:

A temperature rise of 1 °C to 100 °C per minute should be possible across a temperature range from 40 °C to 500 °C. The sample cup should be treated for chemical stability and should be capable of accommodating both liquid and solid samples. It should be possible to maintain the interface between the thermal pyrolysis unit and the gas chromatograph inlet up to 400 °C.

6 Reagents and materials

All reagent chemicals shall be tested for contamination and blank values prior to application as follows.

6.1 **n-hexane**, for preparing the phthalates standard solution, GC grade or higher.

6.2 **Phthalates**, see [Table A.1](#).

6.3 **Helium**, purity greater than a volume fraction of 99,999 %.

6.4 **Calibrants**: prepare stock solutions containing 100 mg/l of each phthalate (see [Annex A](#)) in n-hexane ([6.1](#)).

NOTE A commercially available Certified Reference Materials (CRM) containing specific phthalates could be used as a calibrant.

6.4.1 Stock solution of phthalates, 10 000 mg/l.

Weigh accurately 100 mg of each phthalate (6.2) into a 10 ml volumetric flask (5.12) respectively and dissolve with n-hexane (6.1) and then fill it up to the mark.

6.4.2 Standard solution for calibration curve of phthalates, 100 mg/l.

Add 1 ml of each stock solution of phthalates (6.4.1) to 100-ml volumetric flasks (5.12) and filled up to the mark with n-hexane (6.1).

6.5 Blank material (no phthalate compounds shall be included).

7 Sampling

In the footwear, all types of footwear materials shall be tested except:

- textiles (without any coating), and
- metallic parts.

Information on sampling are given in [Annex B](#)

If the sample consists of homogeneous materials, then the sample shall be cut into small pieces using a cutting tool (5.6 to 5.8). Place approximately 0,5 mg of the cut sample into a pre-weighed sample cup using a micro spatula (5.4) or tweezers (5.5). Record the total weight of the cup with the sample in it to the nearest 0,01 mg and then record the sample weight by subtracting the weight of the sample cup from the total weight.

If the sample consists of heterogeneous materials (multi-layer materials), the sample shall be ground to pass through a 500 µm sieve before extraction. Cryogenic grinding/milling with liquid N₂ cooling (5.2) is recommended. Place approximately 0,5 mg of the powdered sample into a pre-weighed sample cup using a micro spatula (5.4) or tweezers (5.5). Record the total weight of the cup with the sample in it to the nearest 0,01 mg and record the sample weight by subtracting the weight of the sample cup from the total weight.

8 Test procedure

8.1 Test sample preparation

Place an appropriate amount of deactivated glass wool into the cup with the sample to ensure that the sample powder will not spill out. Determine the phthalates by Py/TD-GC-MS (5.13). An example of a programme and the parameters for the GC-MS analysis of the target phthalates are given in [Annex C](#).

The measure of the sample weight using a balance can be unstable at a digit of 0,01 mg. To check the accuracy of the weighting sample, it is recommended to check the reproducibility of the weighting sample. If the reproducibility of weighting one sample five times is below 10 %, it is then possible to use the average value as the sample weight.

8.2 Calibration

Prepare at least three appropriate phthalate calibration solutions.

Example for calibration solutions, see [Table 1](#). 1, 2, 5 and 10 µl of 100 mg/l phthalates standard solution (6.4.2) should be put into the sample cups, respectively.

Table 1 — Calibration standard solution of phthalates

No.	Concentration of each phthalate standard solution mg/l	Volume of each phthalate standard solution μ l	Final concentration μ g
1	100	1	0,1
2	100	2	0,2
3	100	5	0,5
4	100	10	1

8.3 Chromatographic analysis

8.3.1 The chromatography parameters for gas chromatograph – mass spectrometer equipped with a pyrolyzer

Different conditions can be necessary to optimize a specific Py/TD-GC-MS system to achieve effective separation of each phthalate. An example of chromatography parameters and the total ion current chromatogram are shown in [Annex C](#) and [Annex E](#).

8.3.2 Qualitative and quantitative analysis by gas chromatograph – mass spectrometer equipped with a pyrolyzer

Add 5 μ l of mixed standard working solution ([6.4.2](#)) for the calibration and the test sample ([8.1](#)) to the sample cup. Introduce the sample cup into the pyrolyzer, then separate thermally extracted phthalates in specific heat zones into columns for determination of phthalates. If one or more peaks in the chromatogram of the test sample and standard working solution appear at the same retention time, analyse qualitatively by comparing the characteristic ions ([Table A.1](#)) of these peaks in the chromatogram of the test sample and standard working solution. Analyse quantitatively by the external standard calibration method through selected ion.

According to the content of the target phthalate in the test sample, select the standard working solution with a similar concentration and analyse an equal volume of standard working solution and test sample. The response value of each of the phthalates in standard working solution and in the test sample should be in the linear range of the detector.

If the response value of test solution is out of the calibration curve range, reduce the sample weight or adjust the split ratio appropriately before measurement.

NOTE Under the above analysis conditions, GC-MSD total ion chromatogram of 18 kinds of phthalate standards is given in [Annex D](#).

9 Calculation of phthalate compounds in the sample

9.1 Calculation of the phthalate compounds in the sample

The content of each phthalate in the sample is calculated using [Formula \(1\)](#).

$$X_i = \frac{A_i - A_0}{m} \quad (1)$$

where

- X_i is the content of phthalate in the sample, in mg/g;
 A_i is the concentration of phthalate in the test sample, in g;
 A_0 is the concentration of phthalate in the blank sample, in g;
 m is the mass of the sample (see [Clause 7](#)), in kg.

9.2 Performance of the test method

The test results of the comparison with ISO 16181-1 are given in [Annex E](#).

This method is able to detect the phthalates listed in [Table A.1](#) with a limit of the quantification of 30 mg/kg. Results below 30 mg/kg should be reported as not detected.

NOTE For the complex matrix (for example, leather, rubber, materials with a high amount of paraffins), this limit of quantification can be difficult to achieve. That is possible for phthalates that yields a single peak. If a phthalate yields several peaks, it will be difficult to achieve this LOQ

10 Detection limit

The detection limit of phthalates by this method is below 30 µg/g. Results below 30 µg/g should be reported as not detected.

11 Test report

The test report shall include at least the following information:

- a) a reference to this document, i.e. ISO 16181-2:2021;
- b) all information necessary for complete identification of the sample tested;
- c) the amount determined for each phthalate that was requested to be tested in mg/kg or in percentage by mass of each listed phthalate in the tested material;
- d) any deviation from this document;
- e) any unusual features observed.

Annex A (informative)

List of phthalates specified in CEN/TR 16417

Table A.1 — List of phthalates determined by this document

No.	Substance ^a	Abbreviation	CAS RN® ¹⁾
1	Dibutyl phthalate	DBP	84-74-2
2	Benzyl butyl phthalate	BBP	85-68-7
3	Bis (2-ethyl(hexyl)phthalate)	DEHP	117-81-7
4	Di-n-octyl phthalate	DNOP	117-84-0
5	Diisononyl phthalate	DINP	28553-12-0 68515-48-0
6	Diisodecyl phthalate	DIDP	26761-40-0 89-16-7 68515-49-1
7	Diisobutyl phthalate	DIBP	84-69-5
8	Bis(2-methoxyethyl) phthalate	DMEP	117-82-8
9	Diisopentyl phthalate	DIPP	605-50-5
10	N-pentyl-isopentyl phthalate	PIPP	776297-69-9
11	Di-n-pentyl phthalate	DNPP	131-18-0
12	Diisohexyl phthalate	DIHxP	71850-09-4
13	Di-n-hexyl phthalate	DNHP	84-75-3
14	Butyl octyl phthalate ^a	BOP	84-78-6
15	1,2-Benzenedicarboxylic acid, di-C6-8-branched alkyl esters, C7-rich	DIHP	71888-89-6
16	Diisooctyl phthalate ^a	DIOP	27554-26-3
17	Diundecyl phthalate ^a	DUP	3648-20-2
18	1,2-Benzenedicarboxylic acid, dipentylester, branched and linear	DPP	84777-06-0
19	1,2-Benzenedicarboxylic acid, dihexyl ester, branched and linear	DHP	68515-50-4
20	1,2-Benzenedicarboxylic acid, di-C7-11-branched and linear alkyl esters	DHNUP	68515-42-4
21	1,2-benzenedicarboxylic acid, di-C6-10-alkyl esters; 1,2-benzenedicarboxylic acid, mixed decyl and hexyl and octyl di- esters with ≥ 0.3 % of dihexyl phthalate	-	68515-51-5 68648-93-1
22	Diethylphthalate ^a	DEP	84-66-2
23	dimethylphthalate ^a	DMP	131-11-3
24	dicyclohexylphthalate	DCHP	84-61-7
25	Di-n-propyl phthalate ^a	DPRP	131-16-8
26	Dinonyl phthalate ^a	DNP	84-76-4

^a See ISO/TR 16178 and CEN/TR 16417 for detailed information.

¹⁾ CAS Registry Number® (CAS RN®) is a trademark of CAS corporation. This information is given for the convenience of users of this document and does not constitute an endorsement by ISO of the product named. Equivalent products may be used if they can be shown to lead to the same results.

A.1 DPP is a group of branched and linear dipentyl phthalates. It contains DIPP, PIPP and DnPP. Only when three peaks of DIPP, PIPP and DPP co-exist in the same sample should DPP be reported as the sum of these phthalates. Otherwise, report DIPP, PIPP and DnPP individually.

A.2 DHP is a mixture of phthalate containing DNHP and DIHxP which gives multiple peaks in Py-GC-MS chromatogram. If a single peak is found, identify the analyte as DNHP or DIHxP and quantify the sample using routine methodology for DNHP or DIHxP. If multiple peaks are found, identify the analyte as DHP. DHP is reported by semi-quantification with DNHP. Semi-quantify the result of DHP using a calibration curve prepared by DNHP.

A.3 1,2-benzenedicarboxylic acid, di-C6-10-alkyl esters; 1,2-benzenedicarboxylic acid, mixed decyl and hexyl and octyl diesters with $\geq 0,3$ % of dihexyl phthalate (EC No. 201-559-5) (see [Table A.2](#)) is a group of phthalates composed of C6-C10 alkyl esters. Dihexyl phthalate(C6), 1,2-Benzenedicarboxylic acid, di-C6-8-branched alkyl esters, C7-rich(C7), diisooctyl phthalate(C8), diisononyl phthalate(C9) and diisodecyl phthalate(C10) are used for identification. If all identifiers are found in the sample and the amount of dihexyl phthalate contributes ≥ 0.3 % to the total content of all identifiers, report the result of 1,2-benzenedicarboxylic acid, di-C6-10-alkyl esters; 1,2-benzenedicarboxylic acid, mixed decyl and hexyl and octyl diesters with $\geq 0,3$ % of dihexyl phthalate (EC No. 201-559-5) as the sum of concentration of all identifiers. If any one of the identifiers is not detected or the amount of dihexyl phthalate contributes $< 0,3$ % to the total content of all identifiers, reported individually.

Table A.2 — Interpretation for 1,2-Benzenedicarboxylic acid, di-C6-10-alkyl esters; 1,2-benzenedicarboxylic acid, mixed decyl and hexyl and octyl diesters with $\geq 0,3$ % of dihexyl phthalate

Example	Concentration of phthalates µg					Interpretation for 1,2-Benzenedicarboxylic acid, di-C6-10-alkyl esters; 1,2-benzenedicarboxylic acid, mixed decyl and hexyl and octyl diesters with $\geq 0,3$ % of dihexyl phthalate
	DHP (C6)	DIHP (C7)	DIOP (C8)	DINP (C9)	DIDP (C10)	
Sample 1	4	8	17	22	3	Report 54 µg for this phthalate Contribution of DHP = 7.4 %, i.e. $\geq 0,3$ %
Sample 2	2	16	21	34	19	Report 92 µg for this phthalate Contribution of DHP = 2.2 %, i.e. $\geq 0,3$ %
Sample 3	1	312	188	256	144	Report DHP, DIHP, DIOP, DINP and DIDP individually Contribution of DHP = 0.1 %, i.e. $< 0,3$ %
Sample 4	1	20	55	27	0	Report DHP, DIHP, DIOP and DINP individually DIDP is not found in the sample

A.4 DHNUP is a group of phthalates containing mainly three individual phthalates (BOP, DNOP and DUP). DNOP and DUP are found to be the major peaks of DHNUP, therefore these are used as markers for easy identification. If a sample contains both DNOP and DUP, then it is defined as DHNUP. If the sample also contains BOP, this should be included for reporting. See [Table A.3](#).

Table A.3 — Interpretation for DHNUP

Example	Concentration of phthalates µg			Interpretation for DHNUP
	BOP	DNOP	DUP	
Sample 1	2	2	2	10 µg of DHNUP (if both DNOP and DUP are present, then add BOP)
Sample 2	2	1	2	10 µg of DHNUP (if both DNOP and DUP are present, then add BOP)
Sample 3	1	0	5	No DHNUP since no DNOP found, so report BOP and DUP individually
Sample 4	0	1	5	6 µg of DHNUP (both DNOP and DUP are present)

Annex B (informative)

Sampling guidelines

B.1 General

These sampling guidelines are intended to assist in the determination of phthalate content in footwear products. There can be more suitable methods.

B.2 Classification of test sample

B.2.1 General

For sampling, the test sample is classified into two types as follows.

B.2.2 Homogeneous test sample

A homogeneous test sample (see [Figure B.1](#)) is composed of entirely the same components, for example boots, slippers, sandals or plastics made of the same materials.



Figure B.1 — Example of homogeneous test sample

B.2.3 Heterogeneous test sample (multi-layer)

A heterogeneous test sample is composed of several different layers of materials, for example coated textiles (see [Figure B.2](#)).

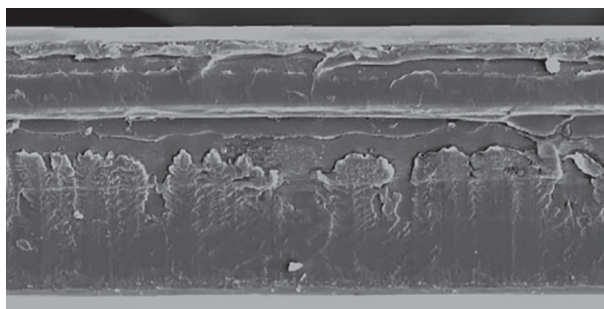

Figure B.2 — Example of heterogeneous test sample; section of multi-layer film

B.3 Sampling

B.3.1 Conditioning of test sample

The sample should be cleaned with a white, dry cloth and kept for at least 12 hours. Before sampling, wipe it again with a white textile, then dry it to see if it smears. If it smears, change the sample or record this in the report. The sample should be stored at (23 ± 2) °C, with a relative humidity of (50 ± 5) %, in order to prevent migration of the phthalate.

B.3.2 Procedure

The method of sampling may be applied differently according to the classification of sample types. If inhomogeneity is suspected in a homogeneous specimen, it may be classified as a heterogeneous sample.

B.3.3 Homogeneous test sample

Since single-layer specimens are made of homogeneous material, take samples with a cutting tool ([5.6](#) to [5.8](#)) in the proper area. However, since the surface of the sample could have been contaminated or transferred, it is recommended that the surface layer is removed and the specimen collected.

B.3.4 Heterogeneous test sample (multi-layer)

In a heterogeneous sample, the material does not have a uniform layered matrix. To make sure it was a representative sample that mirrors the consistency, the test sample can be obtained by using the grinder and mixer, for example the freezing mill (see [Figure B.3](#)) after cutting the multi-layered part. It is recommended that the particle size of the fine particles is preferably 100 µm or less. If the particle size is too large, it is difficult to represent the whole sample.

Freezer milling is a low temperature milling machine. Place the test sample in the sample cell and metal ball inside the vial. Move the vial back and forth or up and down to crush the test sample. By pulverizing the test sample at a liquid nitrogen temperature, the sampling can be performed below the glass transition temperature and is a reliable method for the temperature sensitive samples.

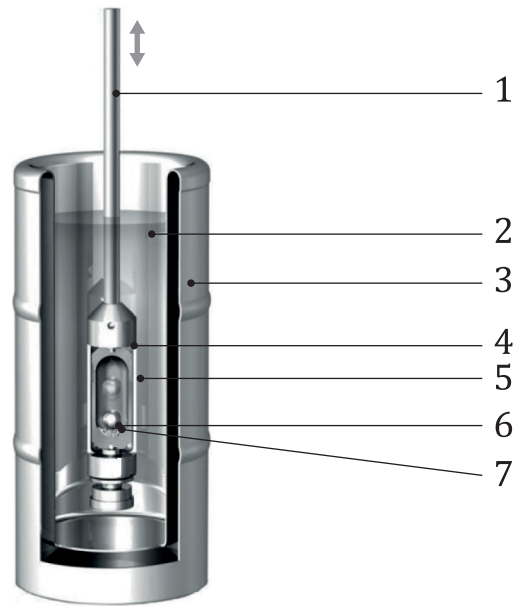
**Key**

- 1 rod
- 2 Liq. N₂
- 3 dewar vessel
- 4 sample cell
- 5 seal
- 6 tungsten ball
- 7 sample

Figure B.3 — Freezing mill

Annex C (informative)

Chromatography parameters for gas chromatography mass spectrometry equipped with a pyrolyzer

As the instrumental equipment of the laboratories can vary, then generally no applicable parameters can be provided for chromatographic analyses. The following parameters have been found to be successful.

C.1 Pyrolyzer

Furnace temperature	200 °C → 20 °C/min → 300 °C (2 min)
Interface temperature	300 °C (interface temperature control mode: manual)

C.2 Gas chromatography

Column	Phenyl-arylene-polymer equivalent to 5 % diphenyl-dimethyl-polysiloxane, length 30 m, inner diameter 0,25 mm, film thickness 0,25 µm
Injection port temperature	320 °C
Column oven temperature	150 °C → (20 °C/min) → 320 °C (5 min)
Injection mode	Split (split ratio: 1/100)
Carrier gas	Helium, 1,5 ml/min

C.3 Mass spectrometry

Ion source temperature	230 °C
Ionization method	Electron ionization (EI), 70 eV.
Scan range	35 m/z to 350 m/z

Table C.1 — Characteristics for Py/TD-GC-MS analysis

No.	Substances	Abbreviation	Quantification ion(m/z)	Confirmation ion(m/z)
1	Dimethyl phthalate	DMP	163	164
2	Diethyl phthalate	DEP	177	149, 105
3	Di-n-propyl phthalate	DPRP	209	149, 191
4	Diisobutyl phthalate	DIBP	57	223, 104, 167
5	Dibutyl phthalate	DBP	223	205, 104
6	Bis(2-methoxyethyl) phthalate	DMEP	59	58, 149, 104
7	Diisopentyl phthalate	DIPP	71	70, 219, 237
8	N-pentyl-isopentyl phthalate	PIPP	71	237, 150, 219
9	Di-n-pentyl phthalate	DNPP	150	237, 219
10	Diisohexyl phthalate	DIHxP	251	85, 233
11	Di-n-hexyl phthalate	DNHP	251	233, 85
12	Butyl octyl phthalate	BOP	223	279, 261
13	Benzyl butyl phthalate	BBP	91	206
14	1,2-Benzenedicarboxylic acid, di-C6-8-branched alkyl esters, C7-rich	DIHP	99	57, 265
15	Diisooctyl phthalate	DIOP	113	279
16	dicyclohexylphthalate	DCHP	167	279
17	Bis (2-ethyl(hexyl)phthalate)	DEHP	249	149
18	Di-n-octyl phthalate	DNOP	279	261
19	Diisononyl phthalate	DINP	293	-
20	Diisodecyl phthalate	DIDP	307	-
21	Dinonyl phthalate	DNP	293	149, 167
22	Diundecyl phthalate	DUP	321	150, 167, 322
23	1,2-Benzenedicarboxylic acid, dipentylester, branched and linear	DPP	TIC	-
24	1,2-Benzenedicarboxylic acid, dihexyl ester, branched and linear	DHP	TIC	-
25	1,2-benzenedicarboxylic acid, di-C6-10-alkyl esters; 1,2-benzenedicarboxylic acid, mixed decyl and hexyl and octyldiesters with ≥ 0.3 % of dihexyl phthalate (EC No. 201-559-5)	-	TIC	-
26	1,2-Benzenedicarboxylic acid, di-C7-11-branched and linear alkyl esters	DHNUP	TIC	-

Annex D (informative)

Verification of the evolved gas analysis (EGA) thermal desorption zone

D.1 EGA thermogram using Py/TD-GC-MS

The thermal desorption zone of the phthalates that is present in the propylene and polyethylene formulations, which are mainly used in the plastics for footwear, are shown in [Figure D.1](#) and [Figure D.2](#). The thermal desorption zone is easily determined using the evolved gas analysis (EGA).

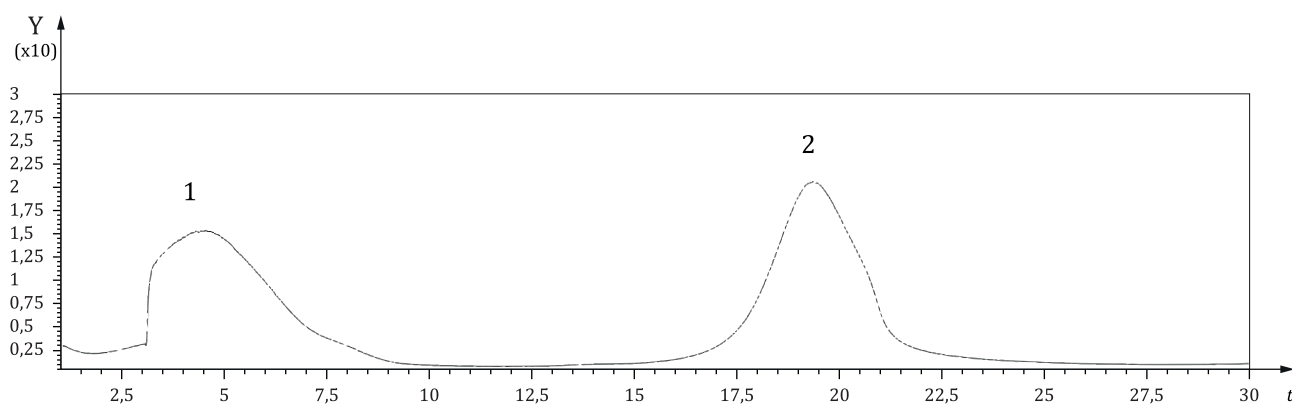

Key

- t temperature (°C)
- Y abundance
- 1 phthalate
- 2 polyethylene

Figure D.1 — Example of the EGA thermogram of a polypropylene sample containing phthalates

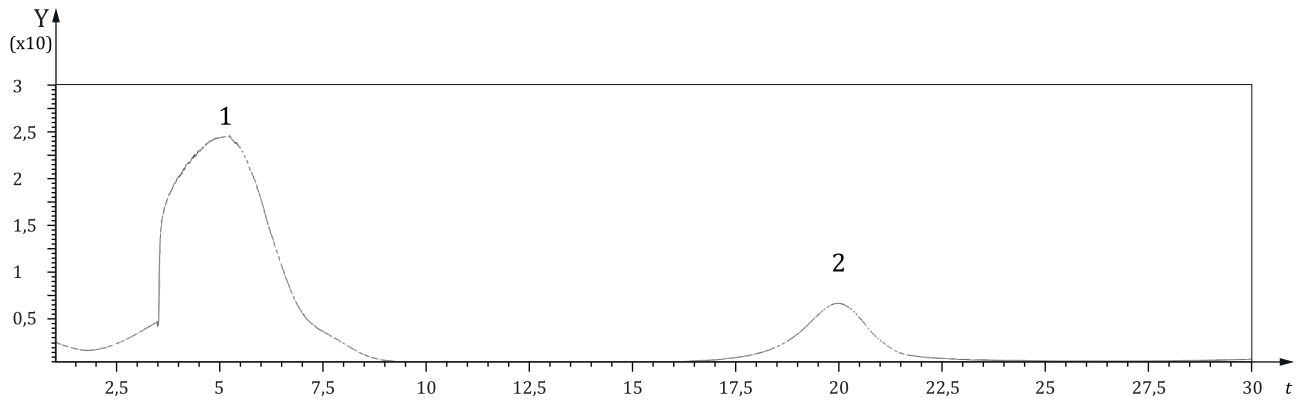
**Key**

- t temperature (°C)
 Y abundance
 1 phthalate
 2 polyethylene

Figure D.2 — Example of the EGA thermogram of a polyethylene sample containing phthalate

D.2 EGA analysis condition of Py/TD-GC-MS

Pyrolysis furnace temperature	100 °C → 20 °C/min → 700 °C
Pyrolysis interface temperature	300 °C (interface temperature control mode: manual)
GC column	deactivated SS tube: 2,5 m x 0,25 mm I.D.
Injection port temperature	320 °C
Column oven temperature	320 °C
Carrier gas	100 kPa (constant pressure)
Split ratio	1/50

Annex E (informative)

Examples of chromatogram for phthalate by Py/TD-GC-MS

An example of a Py/TD-GC-MS chromatogram is shown in [Figure E.1](#).

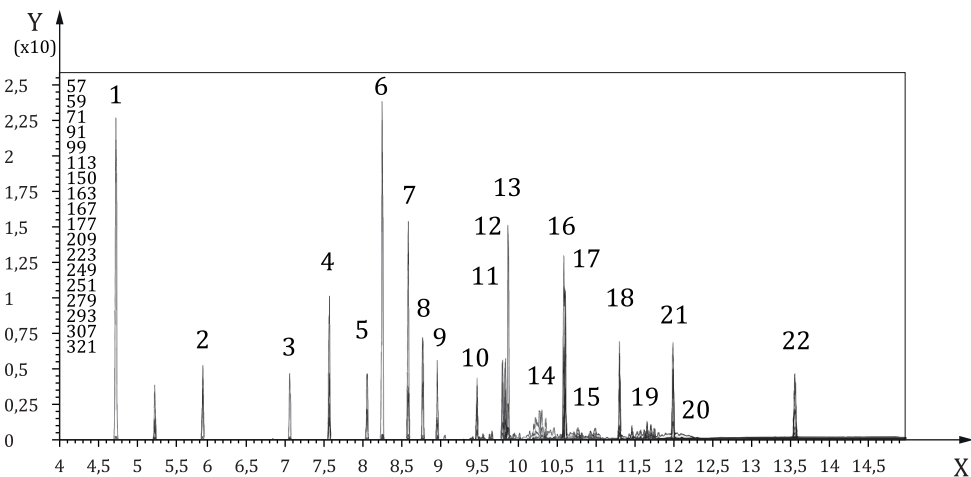
**Key**

X retention time (min)

Y abundance

1 Dimethyl phthalate (DMP)

2 Diethyl phthalate (DEP)

3 Di-n-propyl phthalate (DPRP)

4 Diisobutyl phthalate (DIBP)

5 Dibutyl phthalate (DBP)

6 Bis(2-methoxyethyl) phthalate (DMEP)

7 Diisopentyl phthalate (DIPP)

8 N-pentyl-isopentyl phthalate (PIPP)

9 Di-n-pentyl phthalate (DNPP)

10 Diisohexyl phthalate (DIHxP)

11 Di-n-hexyl phthalate (DNHP)

12 Butyl octyl phthalate (BOP)

13 Benzyl butyl phthalate (BBP)

14 1,2-Benzenedicarboxylic acid, di-C6-8-branched alkyl esters, C7-rich (DIHP)

15 Diisooctyl phthalate (DIOP)

16 Dicyclohexylphthalate (DCHP)

17 Bis (2-ethyl(hexyl)phthalate) (DEHP)

18 Di-n-octyl phthalate (DNOP)

19 Diisononyl phthalate (DINP)

20 Diisodecyl phthalate (DIDP)

21 Dinonyl phthalate (DNP)

22 Diundecyl phthalate (DUP)

Figure E.1 — Total ion current chromatogram of phthalates (Table C.1) by Py/TD-GC-MS

Annex F (informative)

Comparative test results of ISO 16181-1 and this document (i.e. ISO 16181-2)

F.1 Sample 1: PVC

Table F.1 — Comparison of 5 laboratory (average values) in ISO 16181-1 and Lab-3 in this document for sample 1: PVC

Substance	Average (n=5)	Lab-3
DBP	1098	1072
BBP	944	1238
DEHP	885	939
DNOP	979	875
DINP	921	787
DIDP	899	580
DIBP	915	810
DNPP	960	840
DNHP	909	768
DCHP	922	783

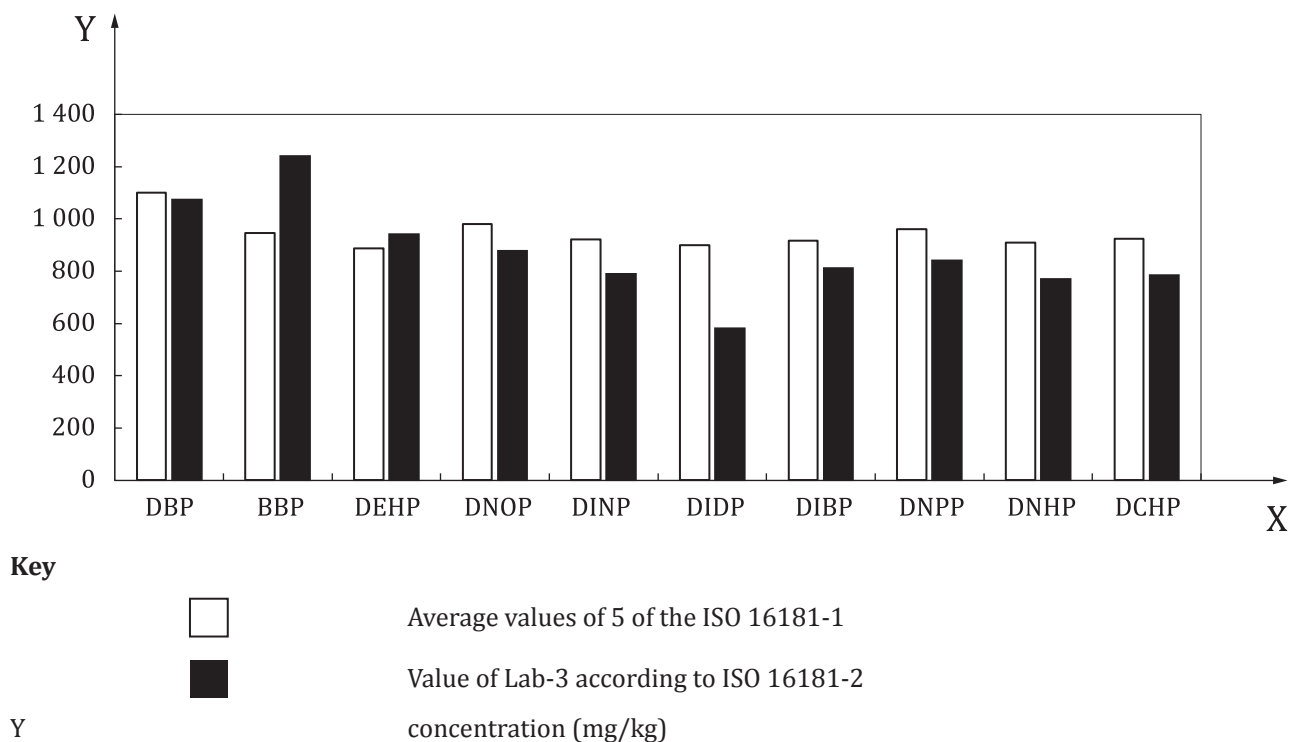

Figure F.1 — Comparison of 5 laboratory (average values) in ISO 16181-1 and Lab-3 in this document for sample 1: PVC

F.2 Sample 2: Textile

Table F.2 — Comparison of 5 laboratory (average values) in ISO 16181-1 and Lab-3 in this document for sample 2: textile

Substance	Average (n=5)	Lab-3
DBP	510	585
BBP	491	544
DEHP	609	302
DNOP	497	478
DINP	526	541
DIDP	632	747

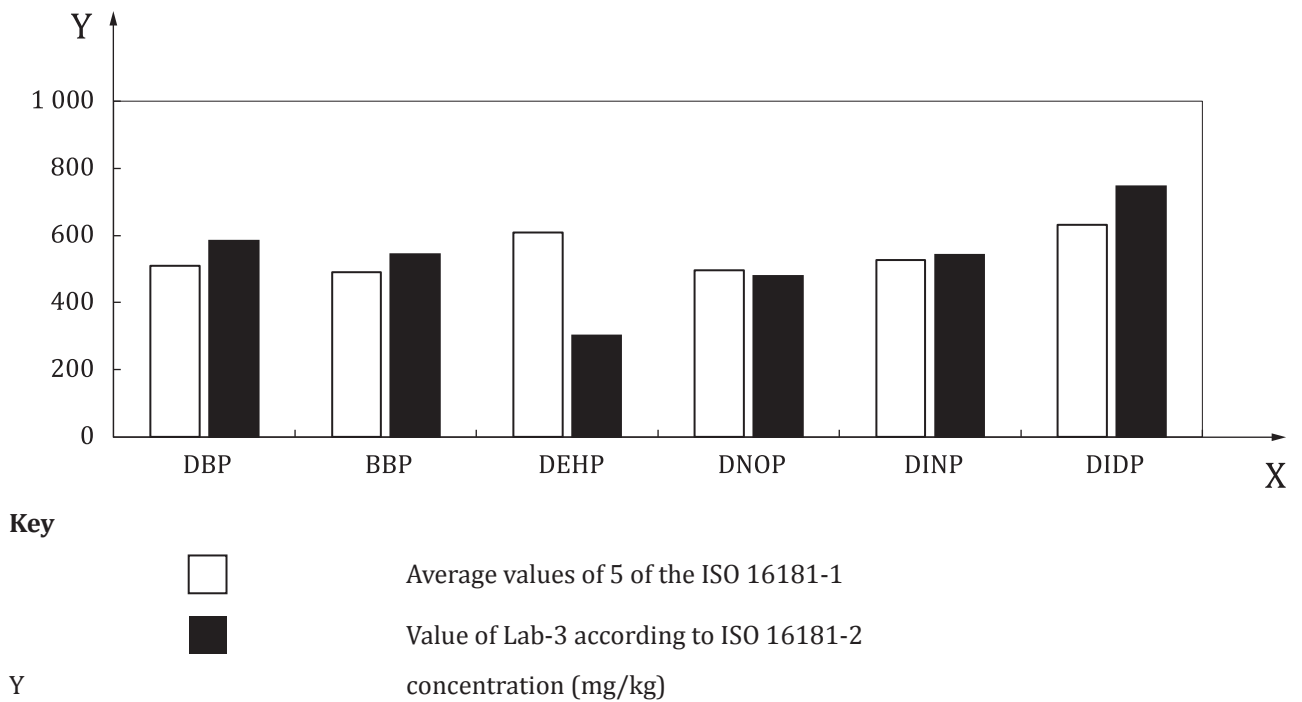

Figure F.2 — Comparison of 5 laboratory (average values) in ISO 16181-1 and Lab-3 in this document for sample 2: textile

F.3 Sample 3: PP Low

Table F.3 — Comparison of 5 laboratory (average values) in ISO 16181-1 and Lab-3 in this document for sample 3: PP low

Substance	Average (n=5)	Lab-3
DBP	91	97
BBP	91	99
DNOP	99	98
DINP	102	107
DIDP	93	103
DIBP	96	103

Table F.3 (continued)

Substance	Average (n=5)	Lab-3
DMEP	100	100
DNPP	98	119
DNHP	93	90
DEP	95	103

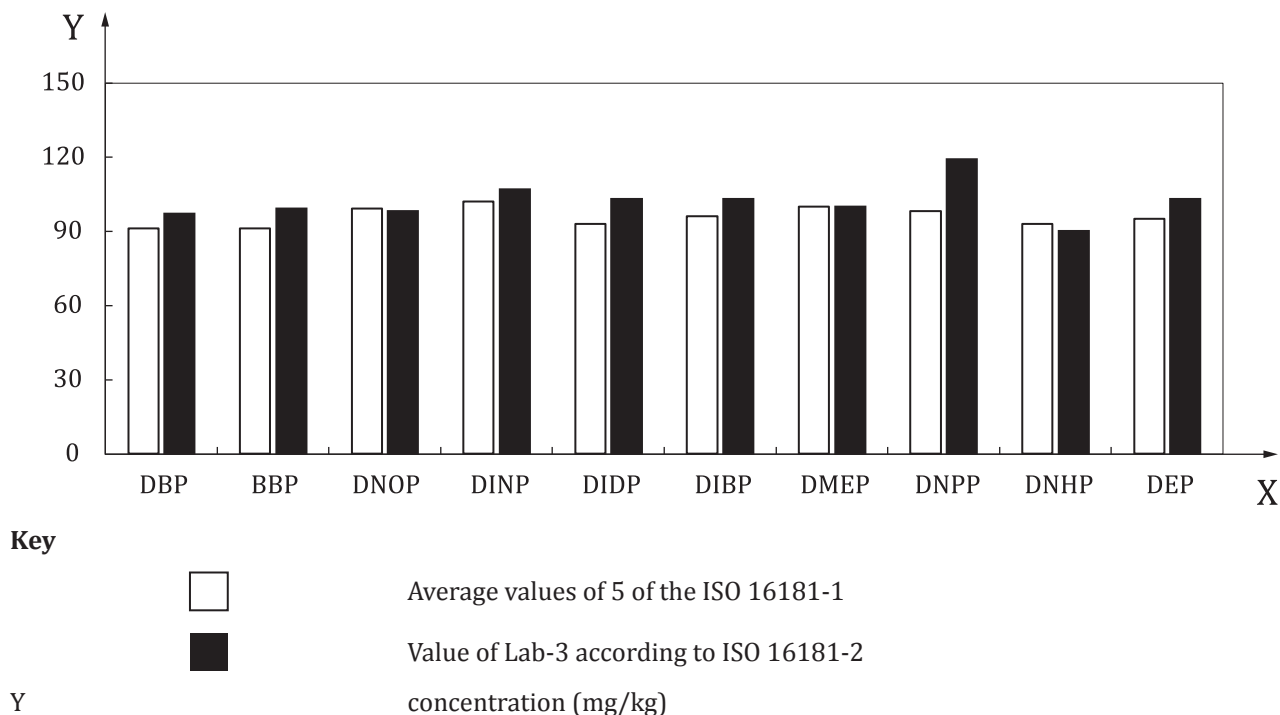

Figure F.3 — Comparison of 5 laboratory (average values) in ISO 16181-1 and Lab-3 in this document for sample 3: PP low

F.4 Sample 4: PP High

Table F.4 — Comparison of 5 laboratory (average values) in ISO 16181-1 and Lab-3 in this document for sample 4: PP high

Substance	Average (n=5)	Lab-3
DEP	891	948
DIBP	927	960
DBP	908	905
DMEP	879	1000
DNPP	934	875
BBP	909	964
DNOP	952	836
DINP	1061	989
DIDP	864	891

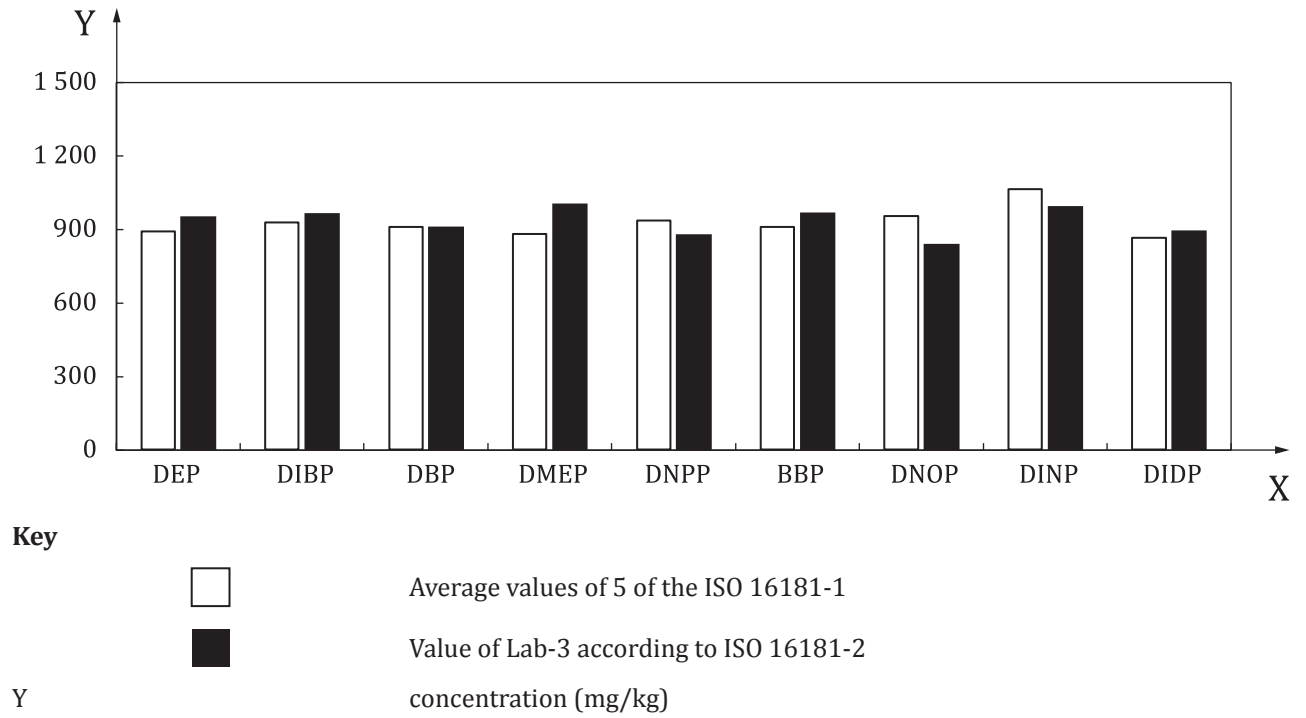

Figure F.4 — Comparison of 5 laboratory (average values) in ISO 16181-1 and Lab-3 in this document for sample 4: PP high

Bibliography

- [1] CEN/TR 16417, *Footwear - Footwear industry guideline for substances of very high concern (Annex XIV of REACH)*
- [2] ISO/TR 16178, *Footwear — Critical substances potentially present in footwear and footwear components*
- [3] KIM, J. W., KIM, Y.M., Moon, H. M., HOSAKA. A., WATANABE, C., TERAMAE, N., Choe, E. K., MYUNG.S.W., *Comparative study of thermal desorption and solvent extraction-gaschromatography-mass spectrometric analysis for the quantification of phthalates in polymers*. J. Chromatogr. A. 2016, p. 1451
- [4] KIM, J. W., KIM, Y.M., Moon, H. M., LEE, M.J., HOSAKA. A., WATANABE, A., TERAMAE, N., PARK, Y. K., MYUNG.S.W., *Rapid Quantification of N-Methyl-2-pyrrolidone in Polymer Matrices by Thermal Desorption-GC/MS*. Anal. Sci. 2017, p. 33

